

HI HEAVY BARRIER.

T.M.

UPRIGHT MODEL NUMBER: 1US33

SERVICE & OPERATION MANUAL

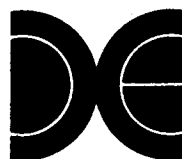
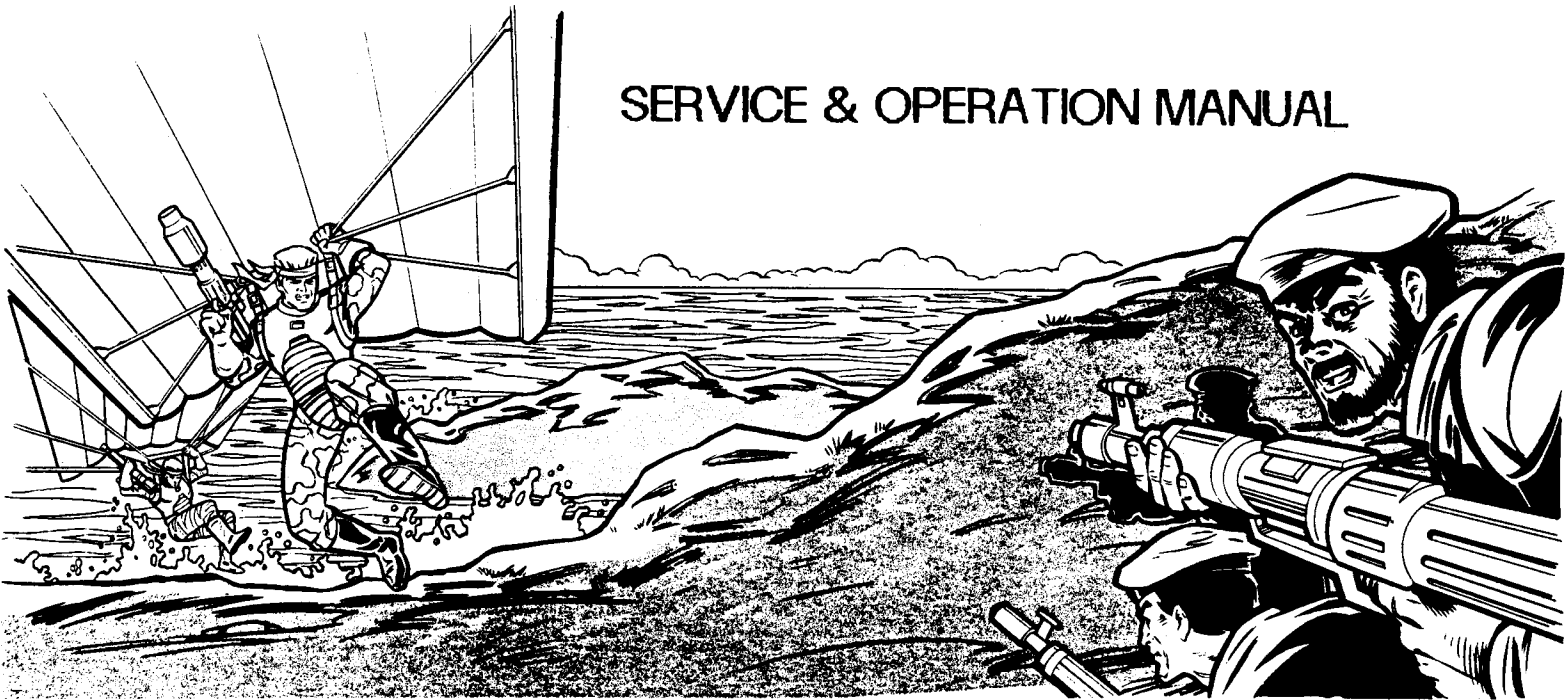

DATA EAST USA, INC.

470 NEEDLES DRIVE
SAN JOSE, CA 95112
TELEPHONE: (408) 286-7074

PART NUMBER: 780-0087-00

FCC WARNING

This equipment generates and uses radio frequency energy and if not installed and used properly, ie; in strict accordance with this instructions manual, may cause harmful interference to radio communications. This equipment has been tested and found to comply with the limits for a Class A computing device pursuant to Subpart J of Part 15 of the FCC rules, which are designed to provide reasonable protection against such interference when the equipment is operated in a commercial environment.

Operation of this equipment in a residential environment is likely to cause interference in which case the user, at his own expense, will be required to take whatever measures are necessary to correct the interference.

FBI WARNING

Federal law provides severe civil and criminal penalties for the unauthorized reproduction, distribution, or exhibition of copyrighted audio-visual works and video games. The Federal Bureau of Investigation investigates allegations of criminal copyright infringement.

COPYRIGHT NOTICE

Heavy Barrel™ is Copyright 1988 Data East Corporation, sold exclusively in the United States of America and Canada by Data East USA, Inc. All rights reserved.

ENVIRONMENTAL DATA

This product is intended for indoor use only, power requirements are 105-125 volts AC, 50-60 hz, and requires a 3 wire grounded outlet.

SERVICE PROCEDURES

To obtain replacement parts and technical service, contact the authorized Data East Distributor in your area. If you require referral or further technical assistance, you may contact Data East's Customer Service department during the hours of 8:00 am to 5:00 pm Pacific Time at (408) 286-7074.

HEAVY BARREL™

UPRIGHT MODEL NUMBER 1U33

SERVICE & OPERATION MANUAL

TABLE OF CONTENTS

1. GENERAL INFORMATION	
A. Installation and Set-Up.....	1
B. System Adjustments.....	2
2. GAME INFORMATION	
A. Game Options.....	3
B. Wiring Diagram.....	4
3. REPLACEMENT PARTS LIST.....	6

© 1988 DATA EAST USA, INC.
470 NEEDLES DRIVE
SAN JOSE, CA. 95112
(408) 286-7074

FIRST PRINTING
FEBRUARY 1988

PN: 780-0087-00

1. GENERAL INFORMATION

A. Installation and Set-Up.

Locate the door keys supplied and remove the Rear Access Door.

Check the Main Harness for loose or unplugged connectors, and check for secure mounting of the monitor, power supply, and game pcb. Stabilize the cabinet using the leg levelers in the floor of the cabinet to prevent the game from rocking.

The selectable options have been pre-set at the factory for optimum player appeal, however, refer to Chapter 2, Section A; Dip Switch Options in this manual to set the game up for special requirements.

Remove the power cord from the inside of the cabinet and insert the strain relief plate into the slot at the bottom of the rear access door opening. Plug the AC cord into a grounded 117 VAC outlet and flip the power switch to the ON position. Allow 2 to 3 minutes for the monitor to warm up and check for proper demonstration mode video on the screen. Insert the proper coinage into a coin slot and start a game. Check for proper operation of all joystick controls and switches.

Complete the Customer Reply Card in the rear of this manual to receive a copy of the Heavy Barrel Technical Support Manual. Please indicate if you would like to receive periodic mailings of technical information, updates, etc.

B. System Adjustments.

The Volume Control, Coin Counter, and Service Switch are located on the Service Panel. The Service Panel is located inside the Coin Door, mounted on the wall of the cabinet on the left side.

The Coin Counter increments once for every coin dropped through either coin entry slots.

The Volume Control is used to adjust the overall loudness of the game sounds. NOTE: The volume control potentiometer on the Main pcb is pre-set to mid-range at the factory and should not be adjusted.

The Service Switch can be used to add credits to the game without incrementing the Coin Counter.

The fuses for the AC power line and the 12 volts for the Coin Door lamps are located on the Power Supply assembly. The fuse holders are labeled as to the proper fuse ratings.

The +5 vdc adjustment level control is on the Power Supply's Switching Regulator is pre-set at the factory. In the event that an adjustment is required, measure the +5 volt level present at the game logic pcb with a Digital Multi-Meter while adjusting the output level of the Switching Regulator. The voltage must measure between +4.90 vdc to 5.10 vdc at the game logic pcb for proper operation.

WARNING: DANGEROUS VOLTAGE LEVELS ARE PRESENT IN AND AROUND THE MONITOR AND POWER SUPPLY ASSEMBLY. ADJUSTMENTS AND REPAIRS SHOULD BE ATTEMPTED ONLY BY QUALIFIED ELECTRONIC TECHNICIANS.

2. GAME INFORMATION

A. Game Options.

The game options can be changed via 2 banks of dip-switches on the game PCB set. Be certain to remove power to the game when changing settings.

DIP SWITCH 1

ITEM	ACTION	1	2	3	4	5	6	7	8
COIN	1 COIN = 1 CREDIT:	OFF	OFF						
VS	1 COIN = 2 CREDIT:	ON	OFF						
CREDIT	1 COIN = 3 CREDIT:	OFF	ON						
COIN 1	2 COIN = 1 CREDIT:	ON	ON						
COIN	1 COIN = 1 CREDIT:			OFF	OFF				
VS	1 COIN = 2 CREDIT:			ON	OFF				
CREDIT	1 COIN = 3 CREDIT:			OFF	ON				
COIN 2	2 COIN = 1 CREDIT:			ON	ON				
DIAGNOSTICS MODE	NO:					OFF			
	YES:					ON			
DEMO MODE SOUND	YES:						OFF		
	NO:						ON		
SCREEN REVERSE	NORMAL:							OFF	
	FLIP:							ON	
DON'T CHANGE									OFF

DIP SWITCH 2

ITEM	ACTION	1	2	3	4	5	6	7	8
NUMBER OF LIVES	THREE (3):	OFF	OFF						
	FIVE (5):	ON	OFF						
	ONE (1):	OFF	ON						
	INFINITE (∞):	ON	ON						
GAME DIFFICULTY	NORMAL:			OFF	OFF				
	HARD:			ON	OFF				
	NORMAL:			OFF	ON				
	FAST:			ON	ON				
BONUS LIVES AWARDED AT:	30K>80K>160K:					OFF	OFF		
	50K>120K>190K:					ON	OFF		
	100K>200K>300K:					OFF	ON		
	150K>300K>450K:					ON	ON		
CONTINUE MODE (BUY-IN)	NO:							OFF	
	YES:							ON	
DON'T CHANGE	:								OFF

B. Wiring Diagram.

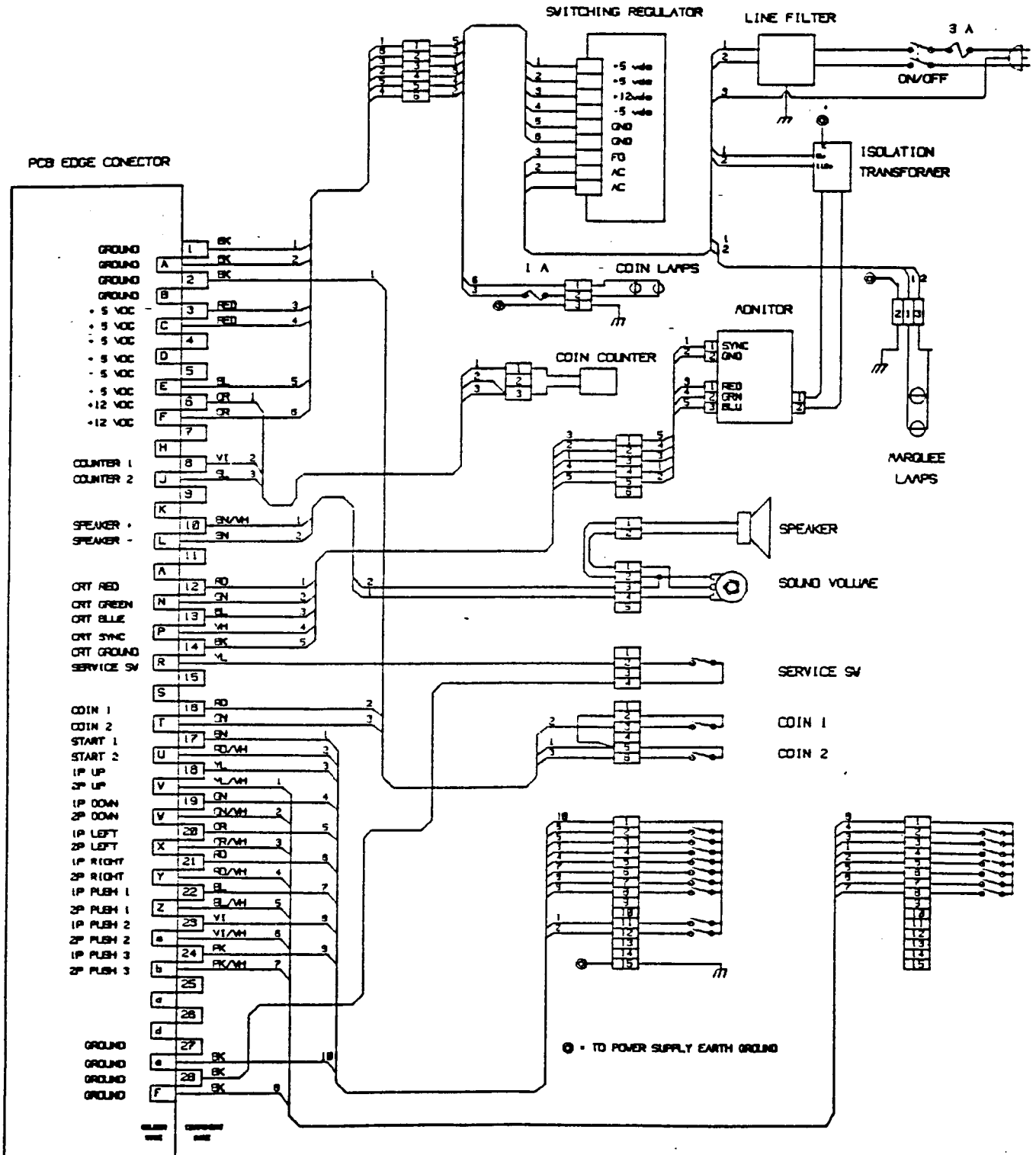

B. Wiring Diagram. (continued)

CONNECTOR 9	
PIN	FUNCTION
1	AUDIO OUT
2	AUDIO GND
3	DC GROUND
4	+ 5 VOLTS
5	+12 VOLTS
6	- 5 VOLTS

CONNECTOR 7 & 8	
PIN	FUNCTION
1	+ 5 VOLTS
2	+ 5 VOLTS
3	GROUND
4	GROUND
5	INPUT XA
6	INPUT XB
7	INPUT YA
8	INPUT YB

CONNECTOR 5 & 6	
PIN	FUNCTION
1	GROUND
2	INPUT 1
3	INPUT 2
4	INPUT 3
5	INPUT 4
6	INPUT 5
7	INPUT 6
8	INPUT 7
9	INPUT 8
10	INPUT 9
11	INPUT 10
12	INPUT 11
13	INPUT 12

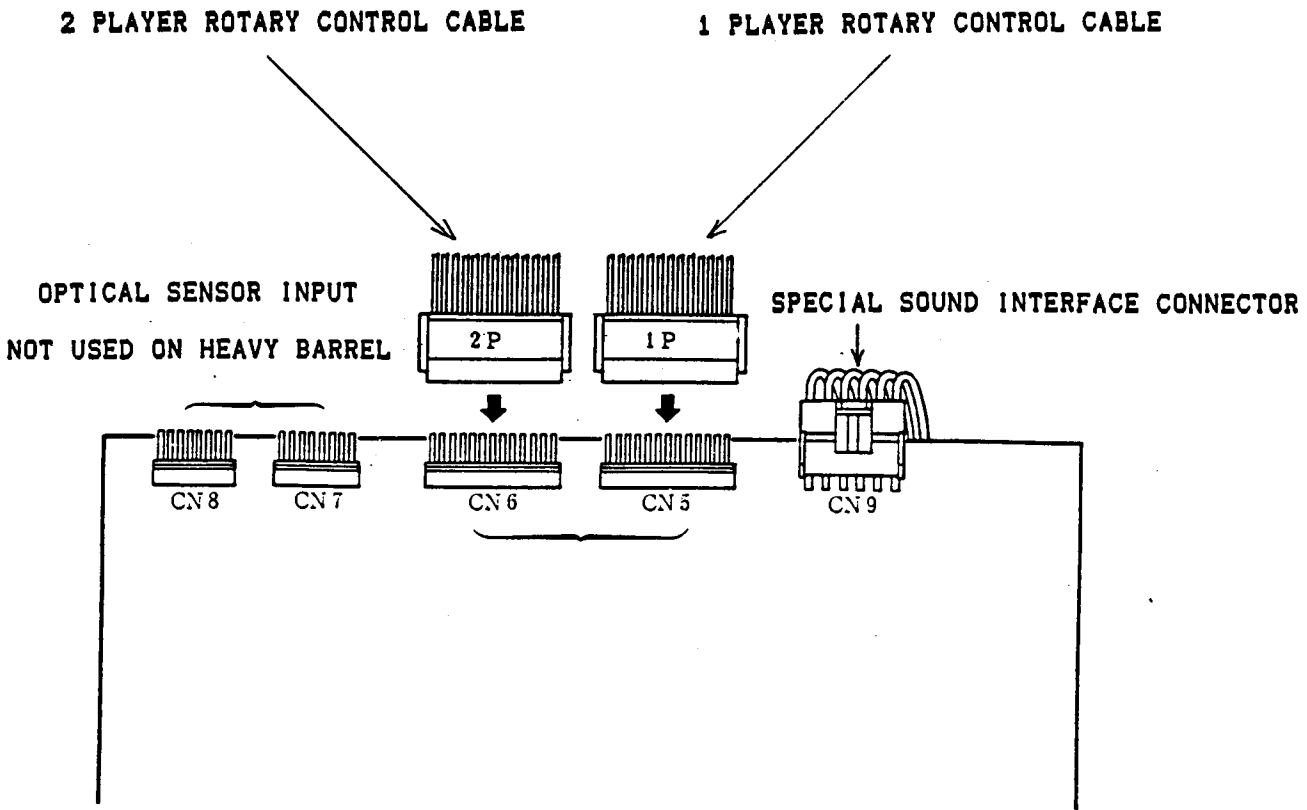

3. REPLACEMENT PARTS LIST

FINAL ASSEMBLY

CABINET, EMPTY, 1US25 STYLE, GREY	365-0010-00
CONTROL PANEL ASSY., HEAVY BARREL	510-0131-00
COIN DOOR ASSY., COIN CONTROL	510-0004-00
MONITOR ASSY., UNIVERSAL H/V	510-0065-00
POWER SUPPLY ASSY., 11AMP	510-0002-01
PCB SET, HEAVY BARREL	510-0126-00
PLEX, CLEAR, DISPLAY 23.75 X 23.75	660-0001-01
UNDERLAY CARD, HEAVY BARREL	810-0029-00
DECAL, SIDE, GENERIC	820-0040-00
PLEX, MARQUEE, HEAVY BARREL	830-0037-00
RETAINER, PLEX, MARQUEE	535-0009-00
SPEAKER, 6 X 9" OVAL	031-0006-00
HARNESS, MAIN, JAMMA STD. U/R	036-0159-02

CONTROL PANEL

CONTROL PANEL, BARE	535-0061-00
OVERLAY, CTRL PNL, HEAVY BARREL	800-0030-00
PUSHBUTTON, RED (GRENADE)	350-0016-02
PUSHBUTTON, YELLOW (START)	350-0016-04
PUSHBUTTON, SHORT, GREY (SHOOT)	350-0001-08
PUSHBUTTON HOLDER W/SWITCH	185-0001-00
PAL NUT, NYLON	240-0001-01
HARNESS, CTRL PNL, 1P/2P, 2S.	036-0115-01
JOYSTICK, ROTARY, WICO	450-0012-00

MISCELLANEOUS PARTS

REGULATOR, 5V @ 11 A & 12V @ 1 A	001-0012-00
ISOLATION TRANSFORMER	010-0001-00
AC LINE FILTER	150-0004-00
CASHBOX, PLASTIC	545-0004-00
FIXTURE, LAMP, DUAL	170-0002-00
LAMP, 40 WATT, INCANDESCENT	165-0004-01
COIN LAMP, 14 VDC .19 AMP WEDGE, #161	165-0009-00
SERVICE PANEL ASSY.	515-0029-02
COIN COUNTER, 12 VOLT	090-0002-00
POT, 100 Ω 4W 1/4" SHAFT	123-0008-11
SWITCH, PUSHBUTTON, MOM. (SERVICE SW.)	180-0022-00

CUSTOMER REPLY CARD

To receive your copy of the Heavy Barrel Technical Service manual (including schematic diagrams), return the form below to the Data East, please include the Serial Number of the game cabinet. No manuals will be sent without Serial Numbers. Indicate if you would like to be on our Direct Mail list for service information.

We welcome your feedback, so please include any comments you have regarding our products and services in the section below and mail this form to:

Data East USA, Inc.
470 Needles Drive
San Jose, CA. 95112
Attn: Customer Service Dept.

HEAVY BARREL TECHNICAL SUPPORT MANUAL REQUEST FORM

COMPANY NAME: _____

ADDRESS: _____

CITY: _____ STATE: _____ ZIP: _____

TELEPHONE: _____

YOUR NAME: _____ TITLE: _____

GAME CABINET SERIAL NUMBER: _____

ADD YOUR COMPANY TO OUR DIRECT MAIL LIST? (circle one) YES NO

COMMENTS: _____

WARRANTY INFORMATION

Data East USA, Inc., ("Seller"), warrants only to the original purchaser ("Buyer"), of its products that the items listed below are free from defects in material and workmanship under normal use and service for the period specified:

GAME LOGIC PRINTED CIRCUIT BOARD(S)	90 DAYS
SWITCHING REGULATOR(S)	30 DAYS
MONITOR PRINTED CIRCUIT BOARD(S)	30 DAYS

No other parts of the Seller's products are warranted.

Warranty periods are effective from date of initial shipment from Seller to Buyer. Seller's sole liability shall be, at its option, to repair or replace products which are returned to Seller during the warranty periods specified, provided:

1. Seller is notified promptly upon discovery by buyer that stated products are defective.
2. Such products are properly packaged and then returned freight pre-paid, to a place specified by Seller.

This warranty does not apply to products damaged during shipment and/or due to improper handling, or due to improper installation or usage, or alteration. In no event shall Seller be liable for any anticipated profits, loss of profits, loss of use, accidental or consequential damages, or any other losses incurred by the customer in connection with the purchase of a Data East USA, Inc., product.

WARRANTY DISCLAIMER

EXCEPT AS SPECIFICALLY PROVIDED IN A WRITTEN CONTRACT BETWEEN SELLER AND BUYER, THERE ARE NO OTHER WARRANTIES, EXPRESSED OR IMPLIED, INCLUDING ANY IMPLIED WARRANTIES OF MERCHANTABILITY OR FITNESS FOR A PARTICULAR PURPOSE.

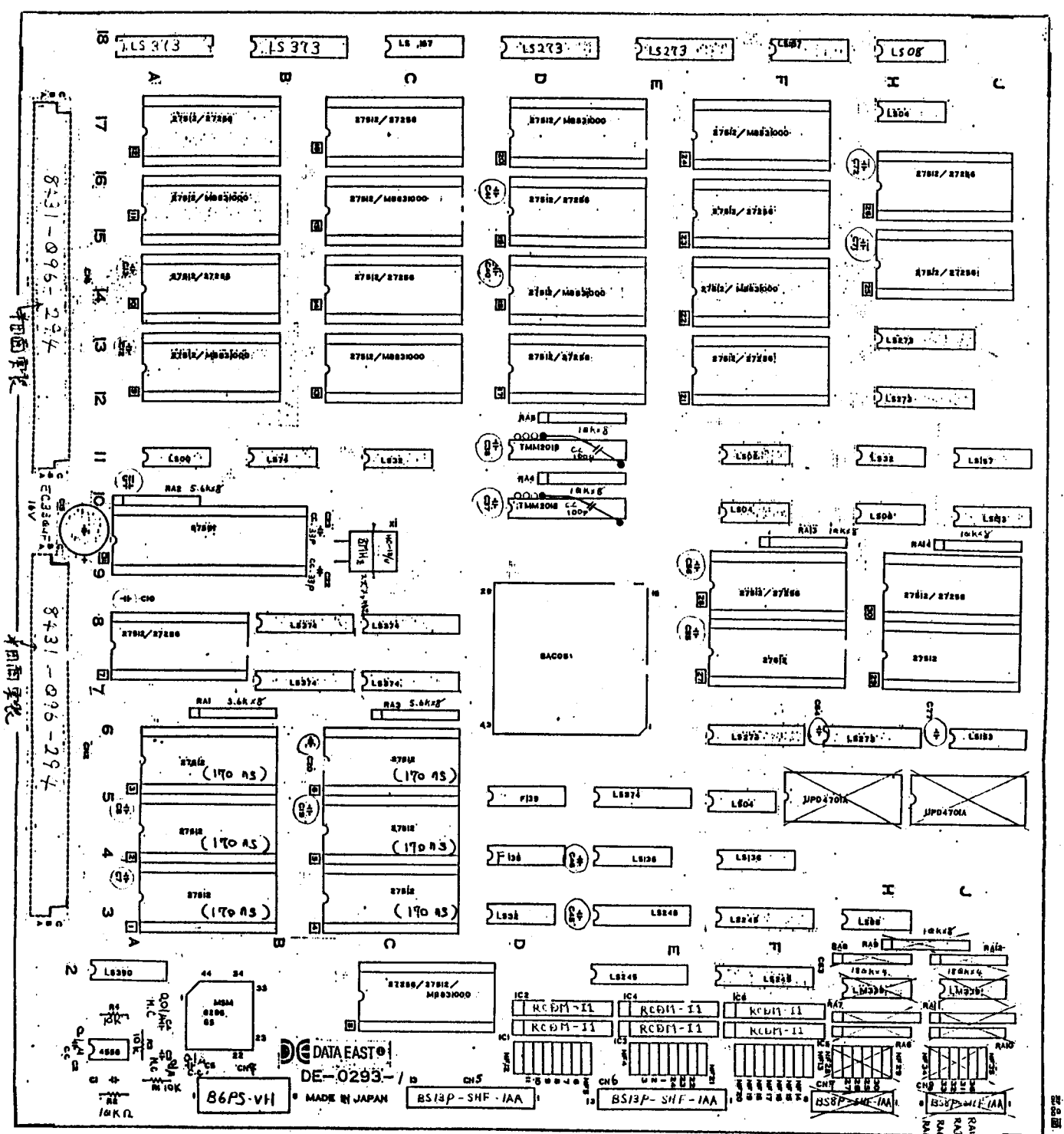

Heavy Barrel.

Back Rom エキ-別巻 L2
 110821, 100821 2 30000 C.C. 100FF 5447
 9402 検査済ニシ、4% 余裕

ROM No. 18 771.0 (4) (4) (4) (4)
 2 100 100 100 100

* ① ~ ④ ROM 12.
 170 AS 233.
 * ⑤ ~ ⑥ ROM 12.
 250 AS 233.
 * X印の部品は必ず交換

* ⑦ EPROM 01A 442
 2333.
 * ⑧, ⑨, ⑩ は
 手回し交換。

* ⑪, ⑫ (LM339)
 は NB 4200 交換
 * ⑬, ⑭ は
 手回し交換

* ⑮, ⑯ (771.0)
 手回し交換

* ⑰, ⑱ (771.0)
 手回し交換

* ⑳ ~ ㉑ (771.0)
 手回し交換

記号	相当	年月日	改訂	個所	符号	部品	図面番号	名称	仕様	材質
材質						公差		名称 DE-0293 SA-10組		
承認	星野	69.11.26	検印	横辺	担当	単位	mm	図面		
						尺度		LK-10103		

部品図

関連番号	仕様、名称
------	-------

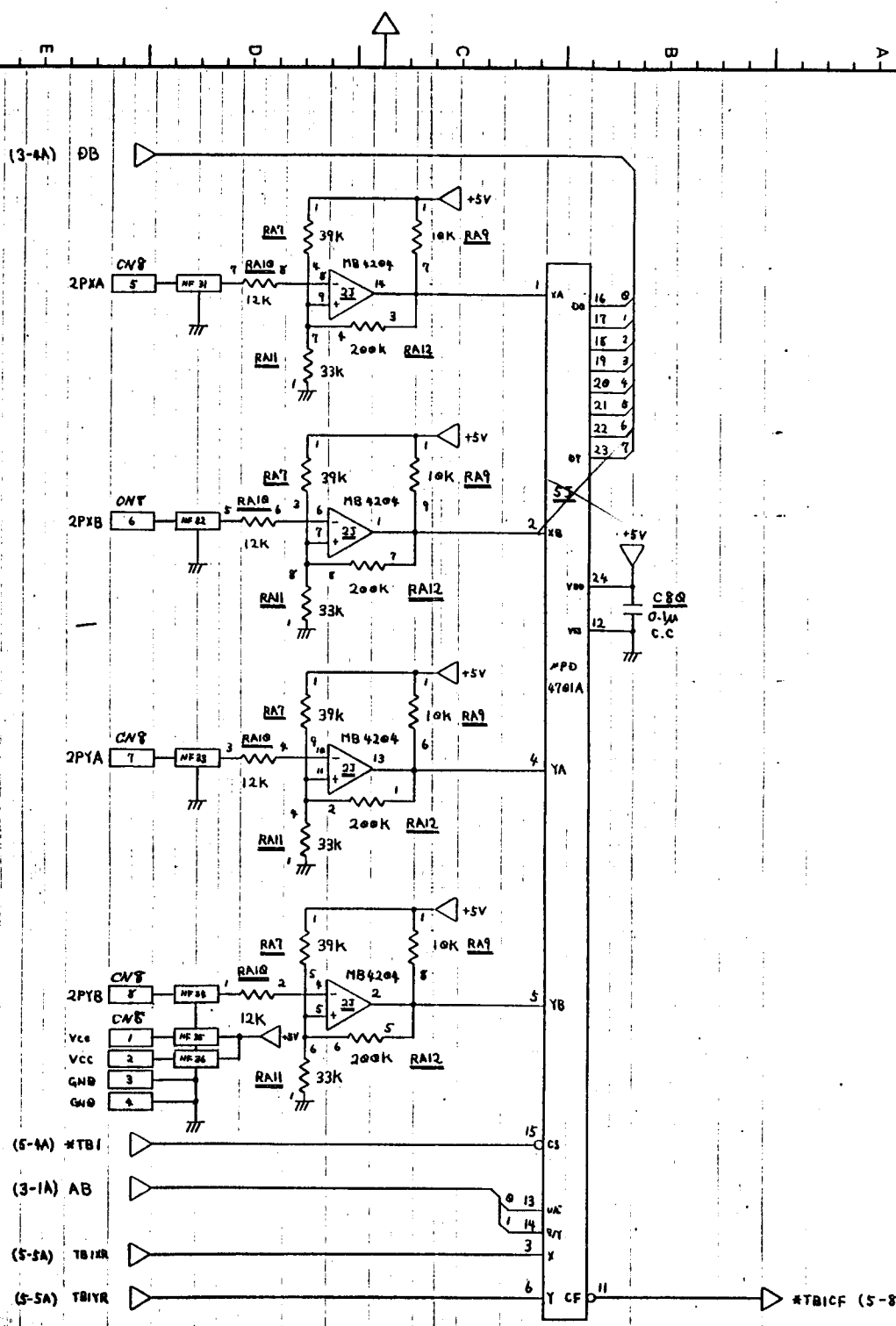

記 事 * 39kΩ、33kΩ 及び 10kΩ の抵抗は、集積抵抗 (5 端子 25V9177) を使用。
 12kΩ、200kΩ の抵抗は集積抵抗 (4 端子 25V9177) を使用。



記号	担当	年月日	改 訂 個 所	符号	部品、図面番号	名称
材質						HFT-Not 回路図

承認	検閲	検印	担当者	単位	図番
63.6.7.6	63.10.22	63.10.18		mm	LK-10082

第 3 角法

開通番号	仕様, 名称
------	--------

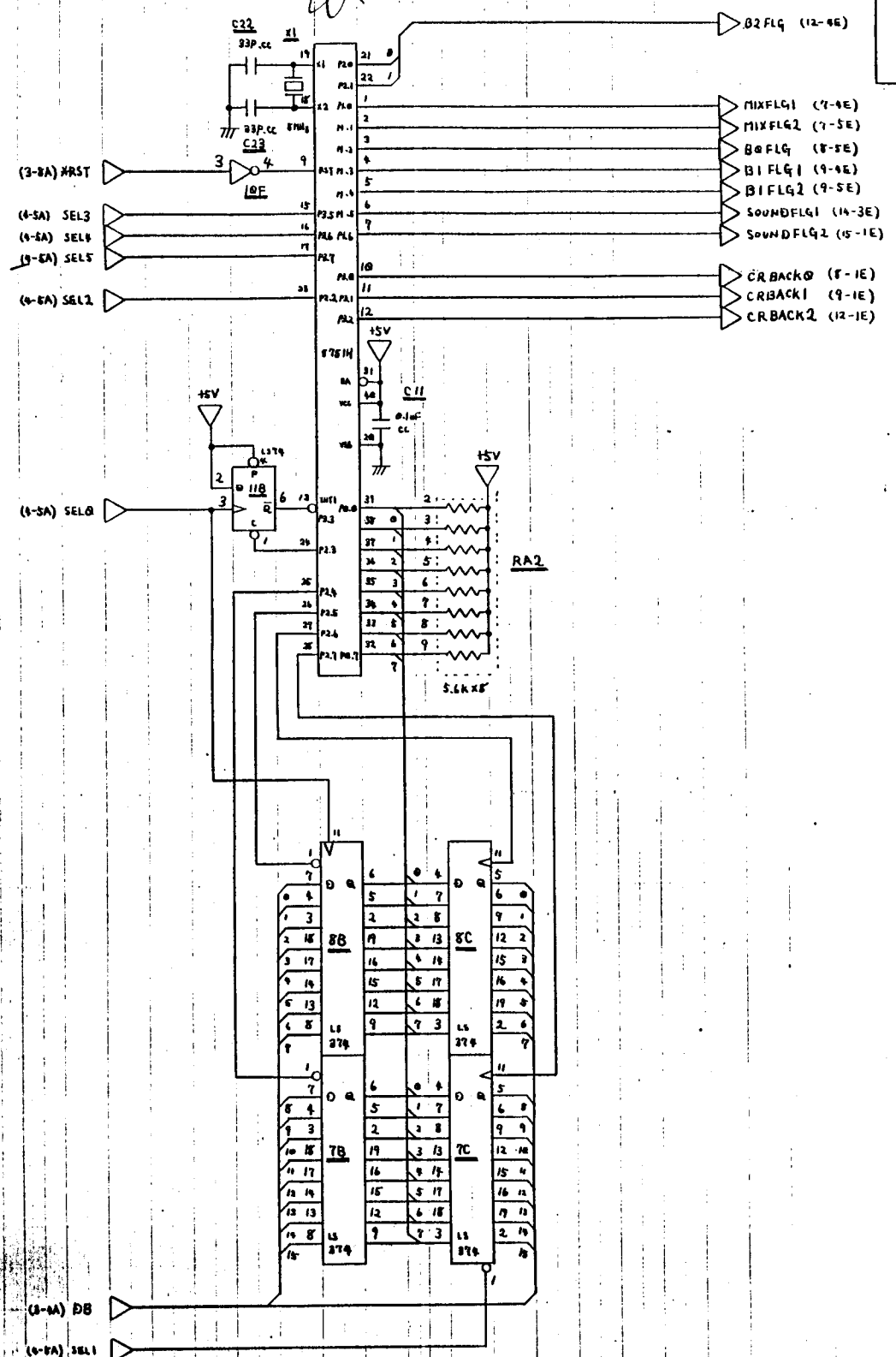

記事

記号担当	年月日	改訂箇所	符号	部品, 図面番号	名称	仕様, 材質
材料		処理			HFT-NOI 回路図	
承認		種類		公差		
検出		形状		単位		
10-22		総数		加		
10-22		17		図番		
		13				
		17				

第3角法

富士通株式会社

関連番号	仕様, 名称
------	--------

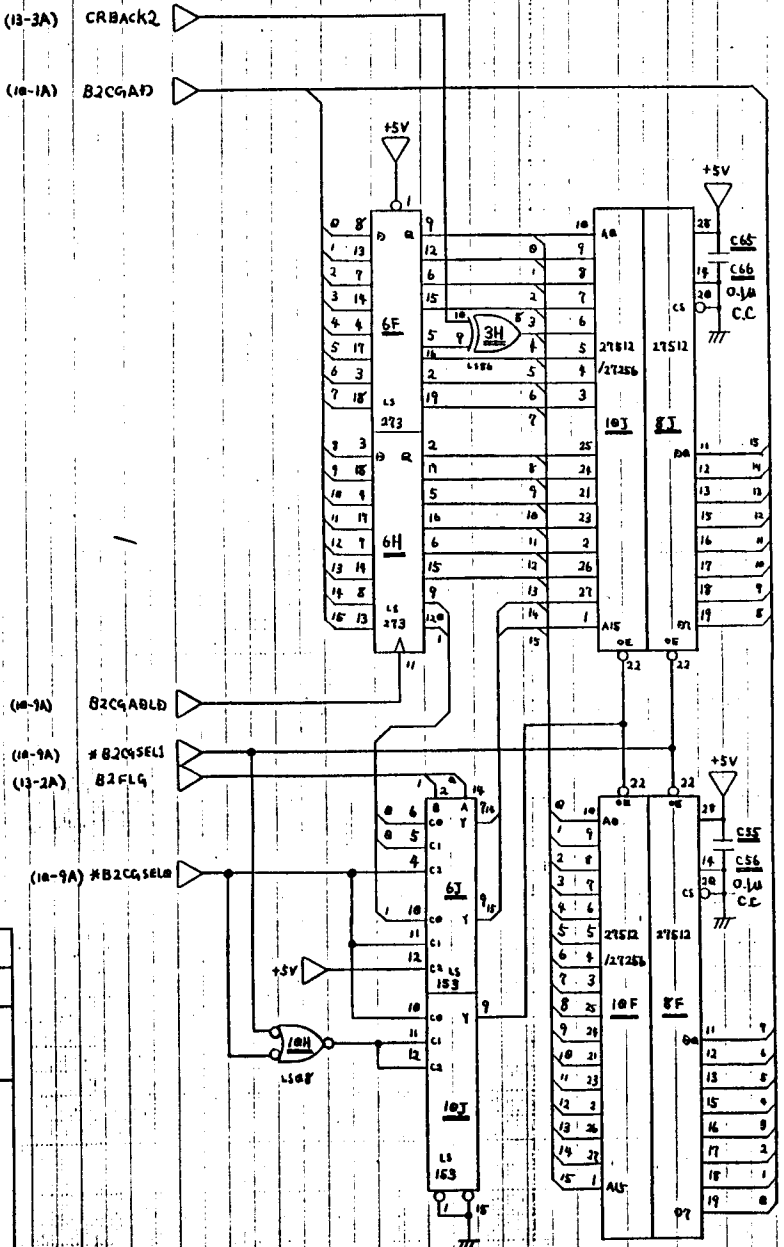

第3角法

記号	担当	年月日	改訂	箇所	符号	部品, 図面番号	名称
材料			処理				
承認	承認	承認	承認	承認	承認	承認	承認
22.11.26	22.10.22	22.10.22	22.10.22	22.10.22	22.10.22	22.10.22	22.10.22
単位	単位	単位	単位	単位	単位	単位	単位
12	12	12	12	12	12	12	12
17	17	17	17	17	17	17	17

HFT-Not 回路図

LK-1a82

富士通株式会社

関連番号	仕様, 名称

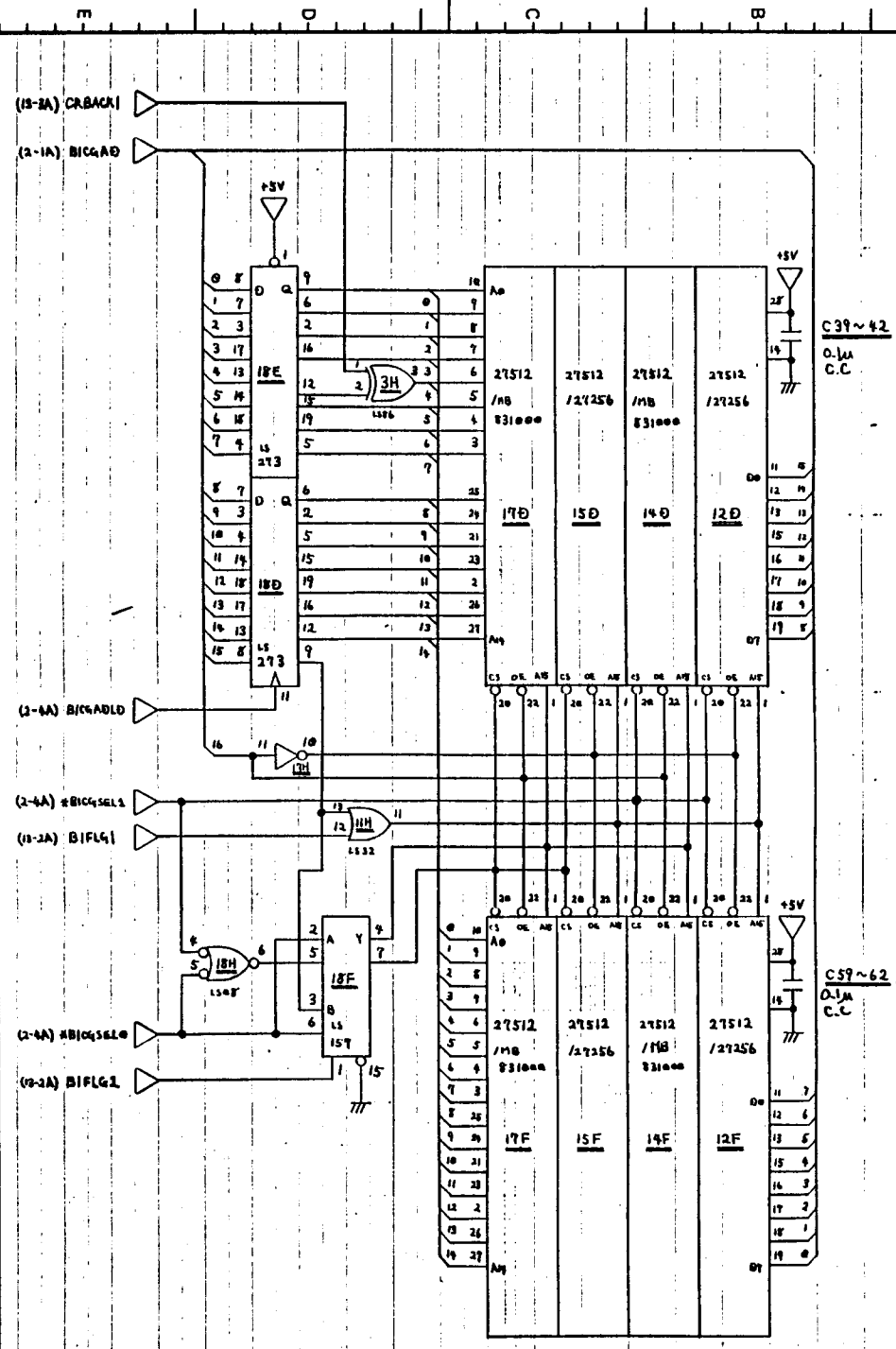

記事

材料	担当	年月日	改訂	備考	符号	部品	図面番号	名称	仕様	材質	数量
								HFT-NOI ② 特別			
承認 2012.10.26	検印 2012.10.26	組立 2012.10.26	単位 mm	公差	図番 LK-10082						9

第3角法

DEPO 三菱電機株式会社

1	開運番号	仕様, 名称
2		
3		
4		
5		
6		
7		
8		
9		

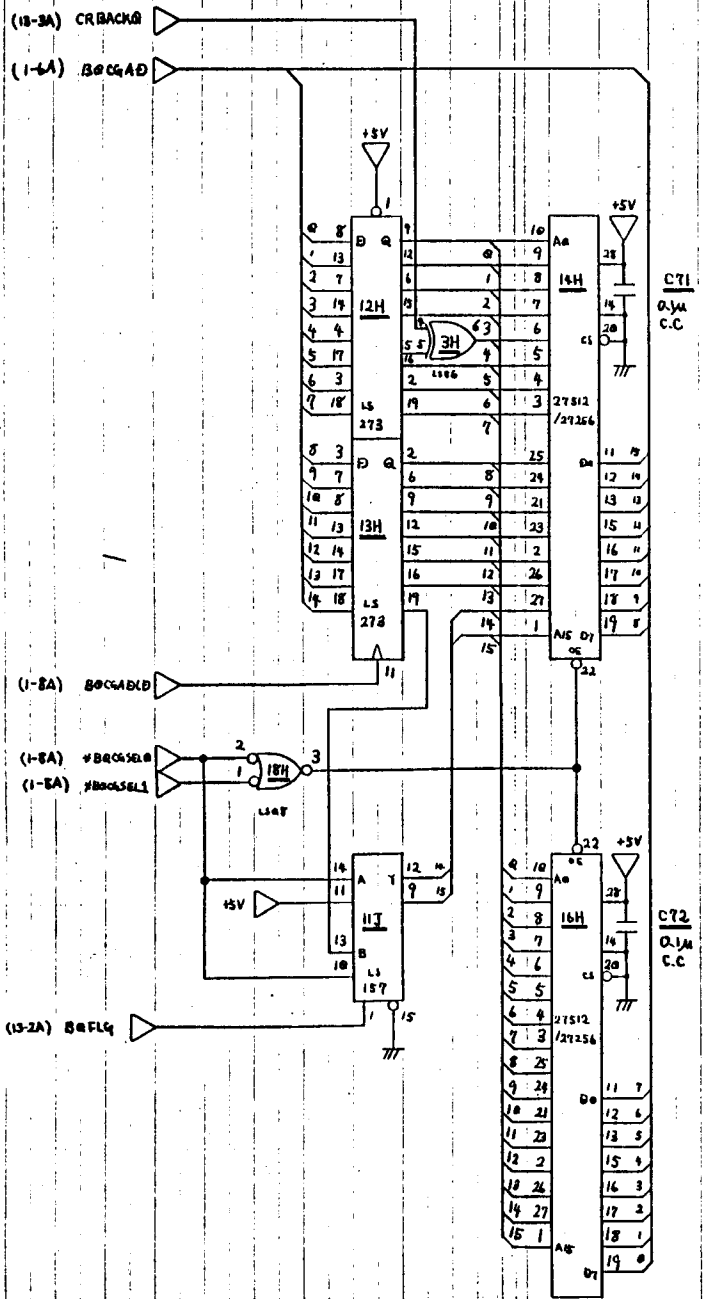

記号	担当	年月日	改訂	個所	符号	部品, 図面番号	名称	仕様, 材質	数量
							HFT-NOI 図9号組		8

材料	処理	公差	名称
承認 22.10.25	承認 22.10.25	承認 22.10.25	LK-10082
承認 22.10.25	承認 22.10.25	承認 22.10.25	

第3角法

株式会社

1	関連番号	
2	仕様、名称	

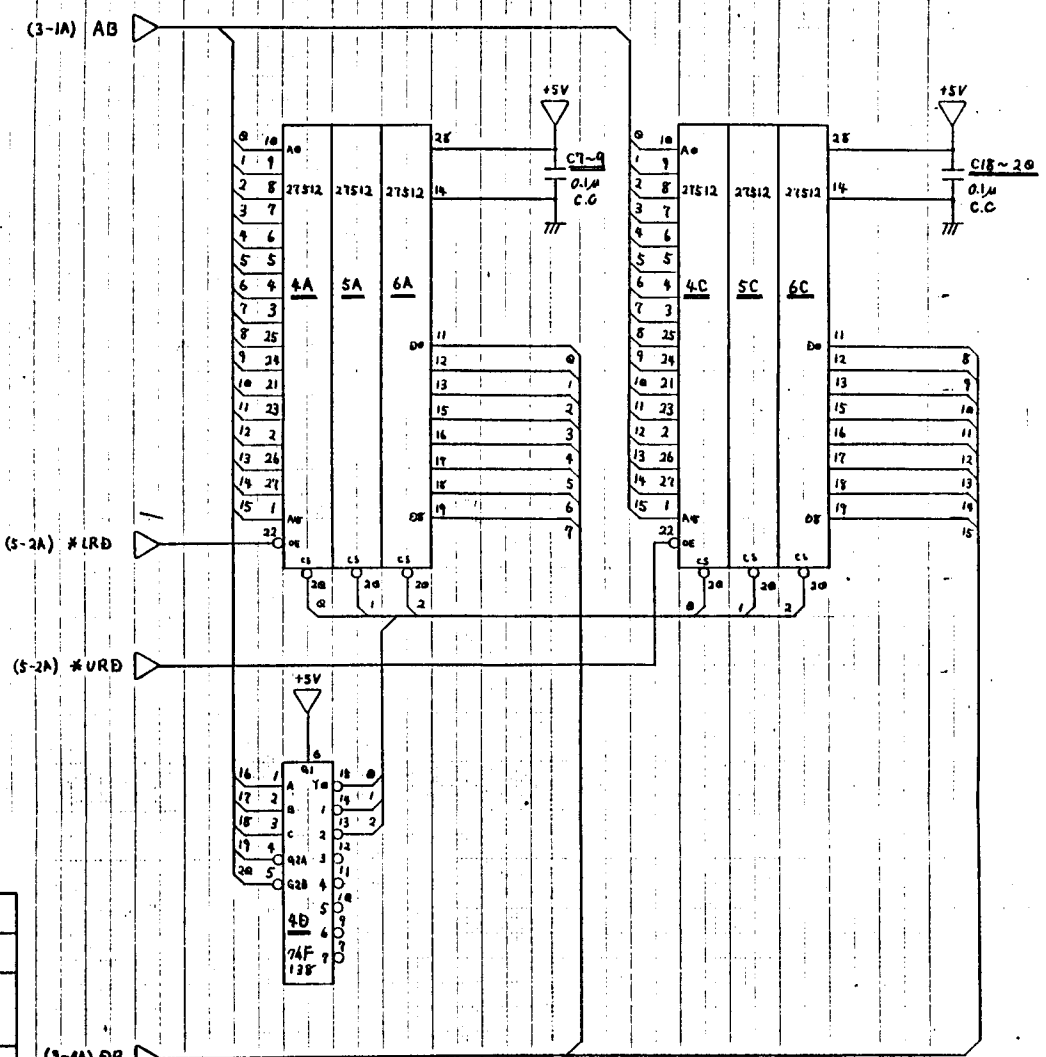

記号
27S12 h. 17005

記号/担当	年月日	改訂/場所	符号	部品、図面番号	名称	仕様、材質
材料		処理			HFT-Not 回路図	
承認	検印	担当	公差	単位	図番	
					LK-10082	
						6/17

第3角法

図番	1
運番	2
号	3
仕	4
様	5
名	6
称	7

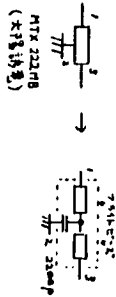
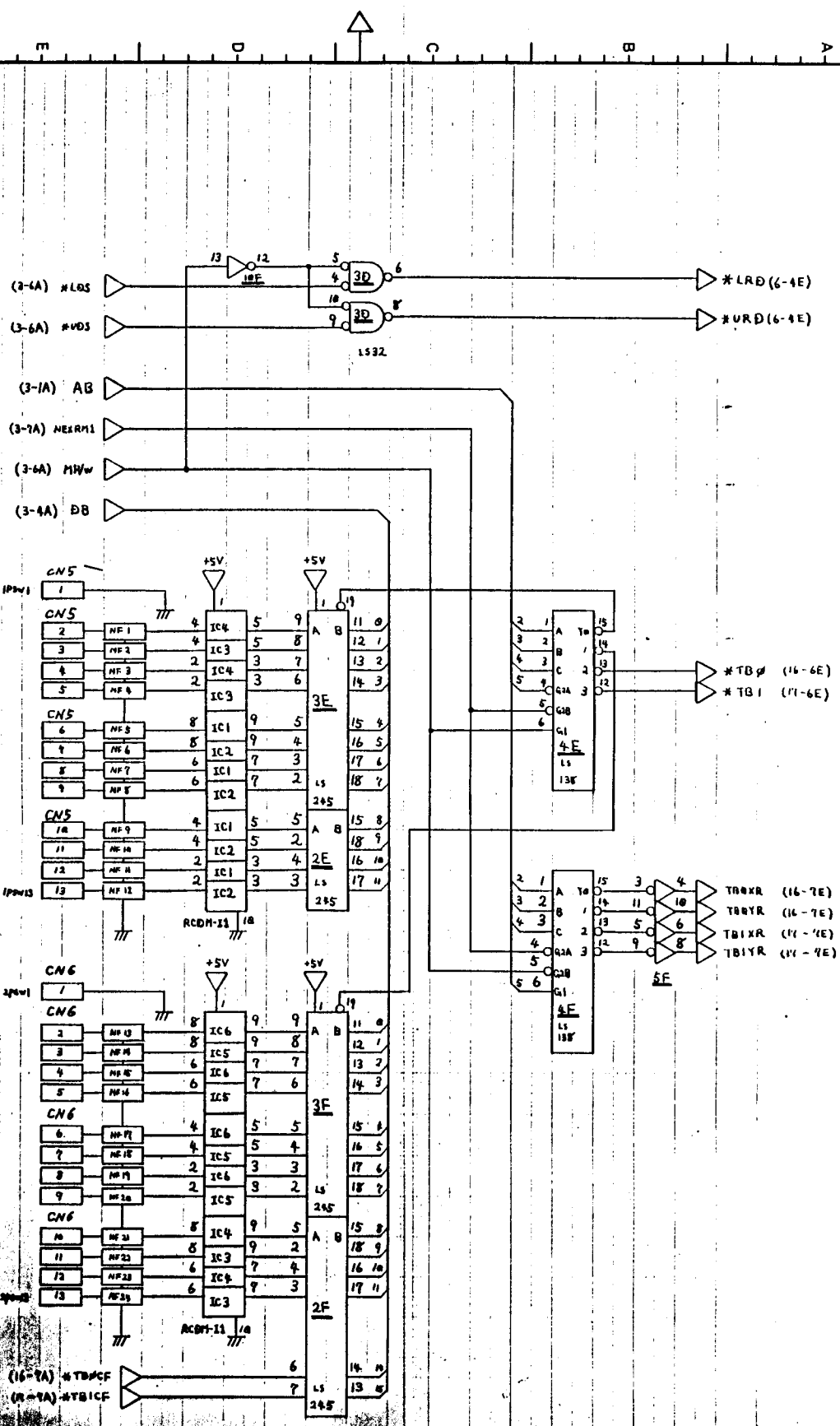

記事

記号担当	年月日	改訂箇所	符号	部品	図面番号	名称
材料		処理		公差		HFT-No.1 回路図

承認	検印	検印	検印	検印	検印	検印
12.11.26	12.10.22	12.8.12				
単位	数量	公差	公差	公差	公差	公差
17						

第3角法

ナカニ一株式会社

関連番号	
仕様、名称	

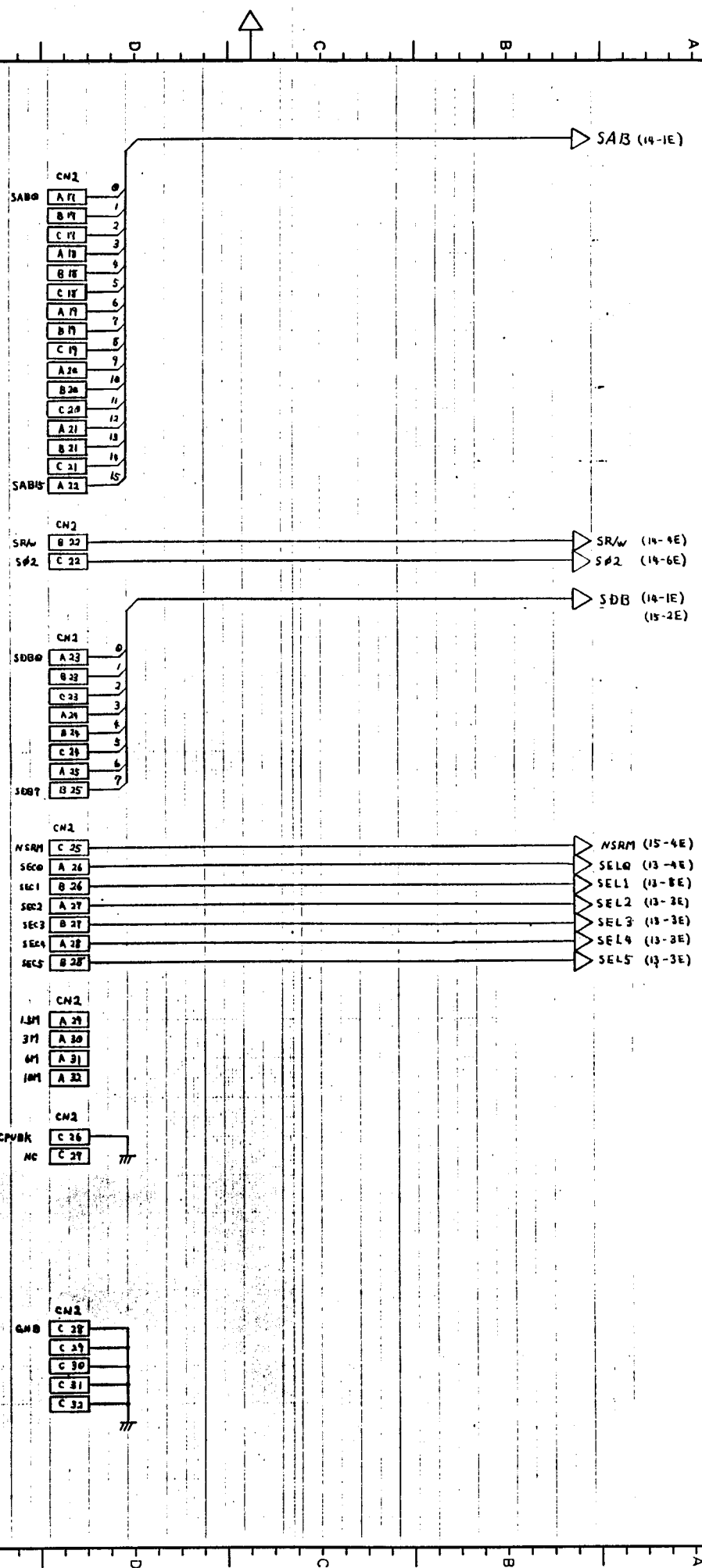

記事

記号	担当	年月日	改訂	備考	符号	部品、図面番号	名称	仕様、材質
材料							HFT-No1 同各図	
承認	受取	検出	検出	検出	検出	検出	LK-10082	
12.11.20								
4								
17								

第3角法

株式会社

開運番号	仕様、名称

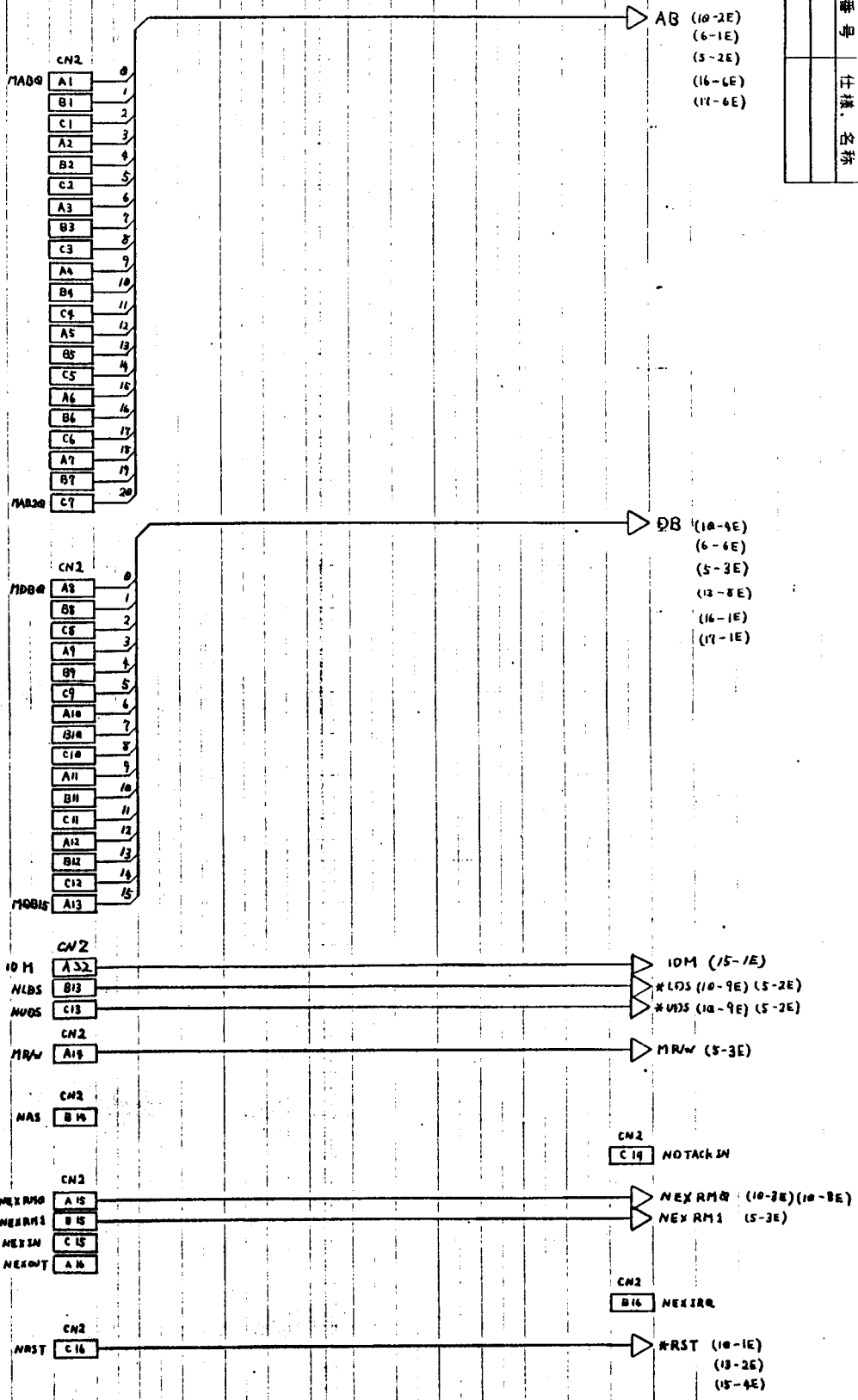

記事

材料	記号	担当	年月日	改訂箇所	符号	部品、図面番号	名称	仕様、材質	数量
							HFT-Not 回路図		3
							Lk-10082		17

第3角法

株式会社

関連番号	仕様、名称

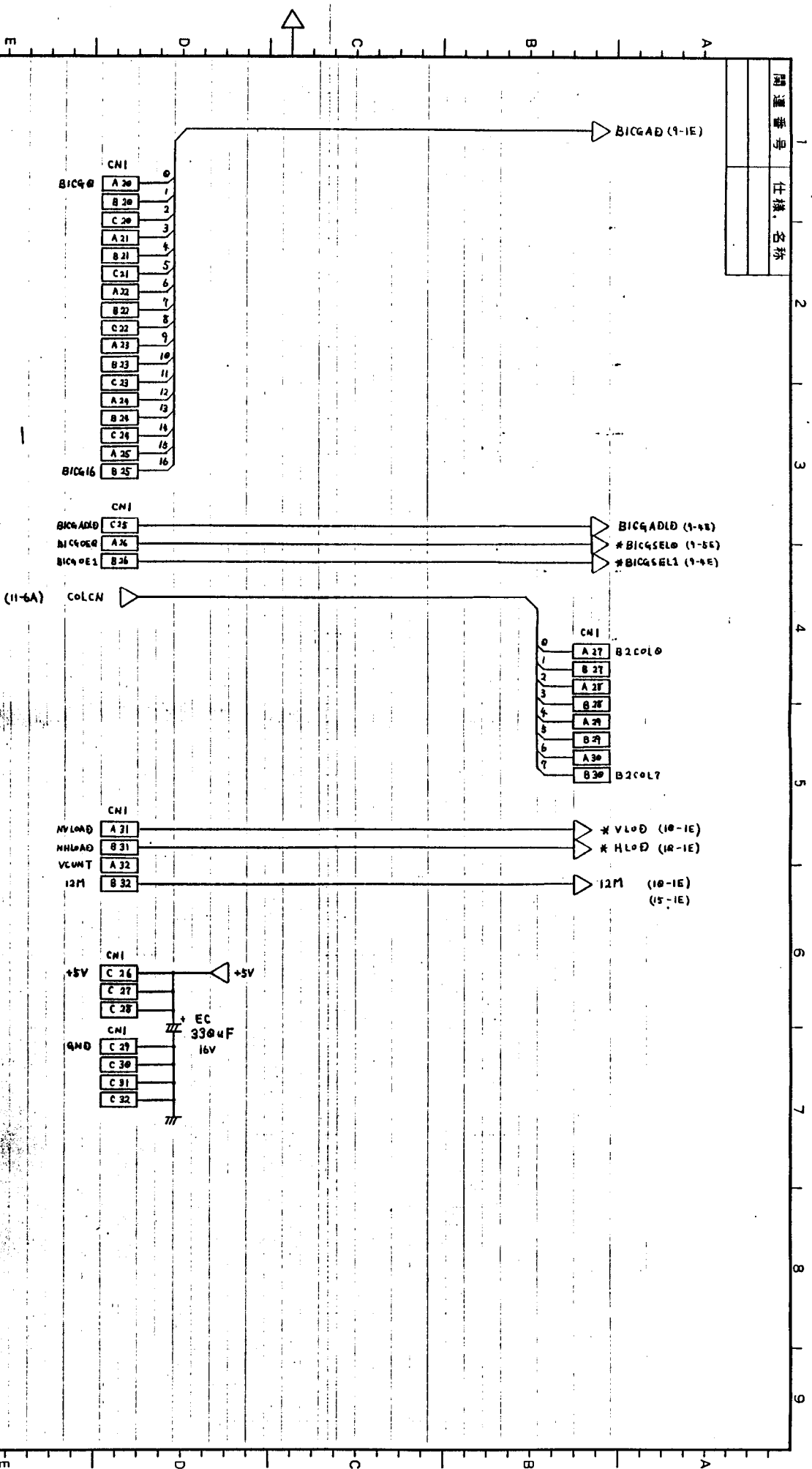

記号	材料	記号	材料	記号	材料	記号	材料	記号	材料

発注先	種類	種類	種類	種類	種類	種類	種類	種類	種類

第3角法

富士通株式会社

名称: HFT-NoI 回路図
 仕様、材質: Lk-10082
 数量: 2
 図番: 17