

Konami[®]/centuri[™]

**CONVERSION KIT
INSTRUCTION MANUAL**

HIGH SCHOOL GRAFFITI

Mikie[™]



centuri[™] inc.

**SALES DEPT.: 305-558-5200
SERVICE: 1-800-327-7710**

MANUAL NO.: 901-2177

"MIKIE"

TABLE OF CONTENTS

	<u>PAGE NO.</u>
CONVERSION KIT CONTENTS -----	2
USER INFORMATION WARNING -----	3
INTRODUCTION & NOTICE -----	4
CONTROL PANEL DECAL PLACEMENT DRAWING -----	5
GAME CONVERSION PROCEDURES -----	6
P.C. BOARD DIAGNOSTIC TEST -----	11
TV MONITOR YOKE ILLUSTRATION -----	12
OPTIONAL DIP SWITCH SETTINGS -----	13
GENERAL WIRING DIAGRAM -----	15
CPU HARNESS DIAGRAM, P/N 008-4948 -----	16

CONVERSION KIT CONTENTS:

MAIN PRINTED CIRCUIT BOARD
P.C. BOARD CAGE (FCC REQUIRED)
CONNECTING WIRING HARNESS
MARQUEE (HEADER) SILKSCREENED
SIDE PANEL GRAPHICS (LEFT AND RIGHT)
CONTROL PANEL OVERLAY
CONTROL PANEL DECALS (BUTTONS AND INSTRUCTIONS)
PUSH BUTTON, WHITE (2 EA.)
PUSH BUTTON, RED (2 EA.)
SWITCH W/HOLDER ASSEMBLY (4 EA.)
4-WAY JOYSTICK
FCC COMPLIANCE LABEL
SCHEMATICS
INSTRUCTION MANUAL

ACCESSORIES, LESS MARQUEE, FOR COCKTAIL TABLE CONVERSIONS
ARE AVAILABLE UPON REQUEST THROUGH OUR SALES DEPARTMENT.

USER INFORMATION

WARNING

F.C.C. REGULATION COMPLIANCE

THE P.C. BOARD METAL CAGE SUPPLIED WITH THIS CONVERSION KIT MUST BE USED AND TERMINATED TO GROUND AT THE TIME OF INSTALLATION.

THIS IS TO AVOID RADIO FREQUENCY RADIATION AND COMPLY WITH THE LIMITS FOR A CLASS "A" COMPUTING DEVICE PURSUANT TO SUB-PART J OF PART 15 OF F.C.C. RULES, WHICH ARE DESIGNED TO PROVIDE REASONABLE PROTECTION AGAINST SUCH INTERFERENCE WHEN OPERATED IN A COMMERCIAL ENVIRONMENT.

OPERATION OF THIS EQUIPMENT IN A RESIDENTIAL AREA IS LIKELY TO CAUSE INTERFERENCE IN WHICH CASE, THE USER AT HIS OWN EXPENSE, WILL BE REQUIRED TO TAKE WHATEVER MEASURES MAY BE REQUIRED TO CORRECT THE INTERFERENCE.

INTRODUCTION

THIS MANUAL CONTAINS STEP-BY-STEP INSTRUCTIONS, WIRING DIAGRAMS, AND SUGGESTIONS TO ASSIST YOU IN PRODUCING A PROFESSIONAL CONVERTED GAME.

WE URGE YOU TO STUDY THIS MANUAL THOROUGHLY BEFORE YOU BEGIN THE CONVERSION.

"MIKIE" CAN BE INSTALLED IN ANY VERTICALLY MOUNTED RASTER SCAN MONITOR ON AN UPRIGHT, MINI, OR COCKTAIL TABLE GAME.

THE CONNECTING WIRING HARNESS PROVIDED WITH THIS KIT INCLUDES ADDITIONAL WIRES, IF NEEDED, FOR CONVERTING TABLE TYPE GAMES. DIP SWITCH SETTINGS ON THE PRINTED CIRCUIT BOARD NEED TO BE CHANGED WHEN CONVERTING TABLE TYPE GAMES.

NOTICE

THIS KIT IS INTENDED TO BE INSTALLED IN ANY VIDEO GAME MANUFACTURED AFTER DECEMBER 1, 1982.

CONVERSION OF OLD EQUIPMENT NOT PREVIOUSLY TESTED TO COMPLY WITH THE LIMITS FOR A CLASS "A" COMPUTING DEVICE PURSUANT TO SUB-PART "J" OF PART 15 OF F.C.C. RULES MAY VOID F.C.C. TYPE ACCEPTANCE.

THE P.C. BOARD CAGE COVER MUST BE REPLACED, IF REMOVED TO FACILITATE MAINTENANCE OF P.C. BOARD ASSEMBLY. AFTER PROPER INSTALLATION AFFIX THE F.C.C. LABEL PROVIDED WITH THIS KIT IN A CLEARLY VISIBLE PLACE OUTSIDE THE EQUIPMENT. ALTERATION OR IMPROPER INSTALLATION OF THIS KIT RELIEVES CENTURI, INC. OF ANY RESPONSIBILITIES.

THE MATERIAL CONTAINED HEREIN IS CONFIDENTIAL AND NO PART OF IT CAN BE REPRODUCED WITHOUT THE EXPRESSED PERMISSION OF CENTURI, INC.

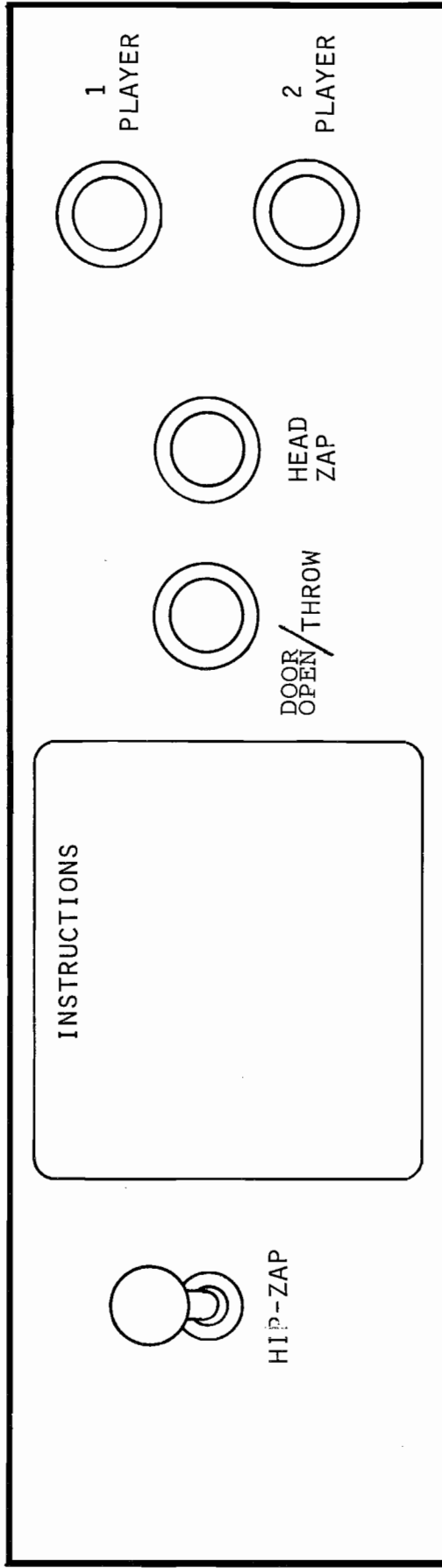

REV. LET.		ECN NO.	REVISION	BY	TOLERANCES		NAME		QC. APV'D	PROD. APV'D	QTY.	ASSEMBLY NO
					Unless Otherwise Specified		CONTROL PANEL DECAL PLACEMENT					
					FRACTIONS	±	1/32	HIALEAH, FLORIDA 33014				
					DECIMALS 2 PL	±	.015	CENTURI inc				
					DECIMALS 3 PL	±	.005	CONTROL PANEL DECAL PLACEMENT				
					HOLES	±	.003	MATERIALS				
					ANGLES	-	.001	HEAT TREAT.				
					SHT. MET BENDS	±	1/2°	FINISH				
							2'	DWN. VT				
								APP'D. DATE				
								10-9-84				
								SCALE				
								NONE				
								PART NO.				
								REV.				

REV. 17899A

CABINET PREPARATION:

NOTE: CABINET SIDE PANELS SHOULD BE THOROUGHLY CLEANED BEFORE APPLYING SIDE GRAPHICS.

USE A HOT AIR BLOWER TO REMOVE OLD "STICK-ON" SIDE GRAPHICS FROM CABINET. THE HEAT FROM THE BLOWER WILL LOOSEN UP THE ADHESIVE, ALLOWING YOU TO PEEL THEM OFF EASILY.

USE ACETONE AND A CLEAN DRY CLOTH TO REMOVE ANY ADHESIVE RESIDUE. CAUTION: DO NOT USE ACETONE ON SURFACES PAINTED WITH FLAT PAINT.

SIDE GRAPHIC APPLICATION:

- * SPRAY A MILD SOAP SOLUTION TO THE CABINET AREA WHERE THE SIDE GRAPHICS ARE TO BE APPLIED.
- * REMOVE THE PROTECTIVE BACKING FROM THE DECALS.
- * POSITION DECALS INTO PLACE.
- * WITH A SOFT SQUEEGEE, AND STARTING FROM THE CENTER OF THE DECAL, SLOWLY PRESS OUT EXCESS SOAP SOLUTION UNTIL A SMOOTH FINISH IS ACHIEVED.
- * ALLOW TO DRY, TWO TO THREE HOURS, BEFORE HANDLING.

CONTROL PANEL PREPARATION:

REMOVE CONTROL PANEL FROM CABINET AND REMOVE ALL PUSH BUTTONS AND/OR JOYSTICK.

DRILL ADDITIONAL HOLES FOR BUTTONS OR JOYSTICK IF NEEDED. REMOVE BURRS FROM DRILLED HOLES BEFORE APPLYING CONTROL PANEL OVERLAY.

OVERLAY APPLICATION:

REFER TO CONTROL PANEL DECAL PLACEMENT DRAWING IN THIS MANUAL.

- * SLOWLY APPLY OVERLAY, REMOVING BACKING AS YOU APPLY IT TO THE CONTROL PANEL SURFACE. BE SURE ALL AIR POCKETS ARE REMOVED.
- * USING AN X-ACTO KNIFE, CUT AROUND JOYSTICK AND PUSH BUTTON PLACEMENTS.
- * APPLY "PLAYER INSTRUCTIONS" DECAL, BY PEELING BACKING AND APPLYING WHERE DESIRED.
- * REMOVE BACKING FROM BUTTON DECALS AND POSITION THEM WHERE PUSH BUTTONS ARE TO BE PLACED. BE SURE DECALS ARE POSITIONED TO ALLOW ROOM FOR PUSH BUTTON PLACEMENT OVER THE DECAL DIE-CUT AREA.

MARQUEE PREPARATION:

THE MARQUEE SHOULD BE CUT TO FIT YOUR GAME. DO NOT REMOVE THE PROTECTIVE MASK UNTIL THIS IS DONE. BE SURE TO PROTECT THE SILK-SCREENED SIDE OF THE MARQUEE FROM ANY SURFACE WHICH MAY MAR OR SCRATCH THE FINISH.

MARQUEE MAY BE CUT BY USING A SCRIBING KNIFE OR A STURDY CRAFT KNIFE. DRAW THE SCRIBER SEVERAL TIMES ALONG A STRAIGHT EDGE HELD FIRMLY IN PLACE CAREFULLY USING FIRM, EVEN PRESSURE.

HOLD THE MARQUEE RIGIDLY UNDER A STRAIGHT EDGE WITH THE SCRIBED MARK HANGING JUST OVER THE EDGE OF A TABLE. USING A CLOTH TO PROTECT YOUR HANDS, APPLY AN EVEN SHARP DOWNWARD PRESSURE TO BREAK THE MARQUEE ALONG THE SCRATCHED MARK. SMOOTH ALL CORNERS AND SHARP EDGES.

CONNECTING HARNESS FAMILIARIZATION:

THE CONNECTING HARNESS HAS BEEN CAREFULLY PREPARED AND LABELED TO AVOID ANY CONNECTING ERRORS. IT IS DESIGNED TO PROVIDE DIRECTION INTO SIX (6) SEPARATE GROUPS, E.G. "TV MONITOR", "SPEAKER", "COIN DOOR", "CONTROL PANEL", "POWER SUPPLY", AND "CONTROL PANEL 2ND PLAYER" (USED ONLY ON COCKTAIL TABLE CONVERSIONS).

THE MOST COMMONLY KNOWN ERRORS MADE DURING CONVERSION, ARE IN WIRE CONNECTIONS AND EDGE CONNECTOR INSERTION. IT IS THEREFORE, OF THE UTMOST IMPORTANCE TO THOROUGHLY STUDY THE EDGE CONNECTOR PIN CONFIGURATION, SO THAT MISTAKES NOT BE MADE DURING WIRE HOOK-UP.

TO ASSIST IN IDENTIFYING THE NUMERICAL SIDE (PIN-1 THRU PIN-18) OF THE CONNECTOR, A PIECE OF TAPE HAS BEEN PLACED ON THAT SIDE. WHEN INSERTED, THE NUMERICAL SIDE OF THE CONNECTOR WILL BE FACING THE COMPONENT SIDE OF THE P.C. BOARD. TO FURTHER FAMILIARIZE YOU WITH THE EDGE CONNECTOR, WHICH CONTAINS 36 PINS DESIGNATED 1 THRU 18 AND A THRU V, THE ORANGE WIRE AT ONE END IS PIN #1 WHEREAS THE FARTHEST END IS PIN #18. ON THE OPPOSITE, OR BOTTOM SIDE OF THE CONNECTOR, PIN "A" HAS NO WIRE AND PIN "V" HAS A RED WIRE. BE SURE TO INSERT THE EDGE CONNECTOR INTO THE P.C. BOARD AS STATED ABOVE.

CONNECTING HARNESS INSTALLATION:

UNPLUG THE MACHINE FROM THE WALL OUTLET TO ELIMINATE SHOCK HAZARDS. CHECK THE POWER SUPPLY ON YOUR OLD GAME. AN ENCLOSED REGULATED POWER SUPPLY RATED AT 6 AMPS WITH VOLTAGE MAINTAINED AT +5, +12, IS MOST APPLICABLE.

IDENTIFY AND SEPARATE THE EXISTING WIRES ON THE OLD GAME INTO SEPARATE GROUPS; TV MONITOR, SPEAKER, COIN DOOR, CONTROL PANEL(S) AND POWER SUPPLY. NO DOUBT, IN SOME CASES, THE WIRE COLORS OF THE NEW KIT HARNESS WILL NOT MATCH TO THE WIRE COLORS OF THE OLD GAME HARNESS. BEFORE PROCEEDING FURTHER, TURN TO THE CPU HARNESS

DRAWING (PART NO. 008-4948) FOUND IN THIS MANUAL.

ON THE CPU HARNESS DRAWING, NEXT TO THE COLOR OF EACH WIRE ON THE ARROWED LINES, WRITE THE COLOR OF THE WIRE FROM THE OLD GAME HARNESS, WHERE IT WILL TERMINATE. FOR EXAMPLE, IF THE WIRE ON THE OLD GAME HARNESS LEADING TO 1ST PLAYER START IS "YELLOW", WRITE "YELLOW" NEXT TO WHT FROM PIN "E" ON THE ARROWED LINE.

TAKING ONE WIRE GROUP AT A TIME, AND ALLOWING ENOUGH WIRE FOR THE NEW HARNESS TO BE ATTACHED, CUT THE WIRES LEADING TO THE OLD P.C. BOARD. CUT THE WIRES DIAGONALLY TO ELIMINATE A BULKY CABLE APPEARANCE, ONCE THE CONNECTIONS ARE MADE, WIRES EITHER CAN BE ATTACHED WITH A BUTT CONNECTOR OR SOLDERED AND COVERED WITH SHRINK-TUBING FOR A MORE PROFESSIONAL LOOK.

A WORD OF CAUTION WHEN CONNECTING THE BLACK WIRES FROM THE NEW KIT EDGE CONNECTOR. THESE WIRES ARE DC GROUND AND ARE NOT TO BE CONFUSED AND CONNECTED TO THE BLACK WIRES OF THE CABINET A.C. CIRCUIT.

BLACK WIRES IN AN A.C. CIRCUIT ARE "HOT" AND CARRY A POTENTIAL OF 120 VOLTS, WHITE IS "NEUTRAL" AND GREEN IDENTIFIES EARTH GROUND.

THE BLACK GROUND WIRES ON THE EDGE CONNECTOR ARE CONNECTED IN PARALLEL WITHIN THE P.C. BOARD AND ONLY ONE WIRE (18 GAUGE PIN U) IS REQUIRED FOR DC GROUND PURPOSES. THIS WIRE SHOULD BE ATTACHED TO THE POWER SUPPLY GROUND (GND) OR FRAME GROUND (F/G) TERMINAL.

DO NOT INSERT THE 36 PIN EDGE CONNECTOR INTO THE P.C. BOARD UNTIL ALL WIRES HAVE BEEN CONNECTED AND THOROUGHLY TESTED TO EACH TERMINATING POINT.

CAGE INSTALLATION:

LOCATE AN AREA INSIDE THE CABINET WHICH WILL ALLOW YOU TO INSERT OR REMOVE THE P.C. BOARD ASSEMBLY WITHOUT ANY PROBLEM.

INSTALL THE GALVANIZED METAL WITH PLASTIC GUIDES CAGE WITH FOUR (4) LARGE SCREWS (NO.8) IN AN ACCESIBLE AREA AGAINST THE SIDE PANEL OF THE CABINET.

IF NEEDED, ELEVATE THE METAL CAGE WITH 3/4 INCH THICK PLYWOOD OR PARTICLE BOARD BETWEEN THE CAGE AND CABINET.

AFTER THE MAIN METAL CAGE HAS BEEN INSTALLED, SLIDE THE P.C. BOARD ASSEMBLY ON THE PLASTIC GUIDES AND PUSH IT ALL THE WAY IN. THE P.C. BOARD CONNECTING EDGE MUST BE FACING TOWARDS THE OUTSIDE OF THE CAGE WITH THE COMPONENT SIDE UP, FACING THE LARGE PERFORATED METAL COVER.

ATTACHED THE LARGE TOP PERFORATED METAL COVER TO THE MAIN CAGE WITH FOUR (4) SMALL SCREWS (NO.4) SUPPLIED WITH YOUR KIT.

CONNECT THE NEW HARNESS CONNECTOR TO THE P.C. BOARD WITH THE TAPE UP, VISIBLE FROM YOUR SIDE. CAREFULLY PLACE THE WHITE PROTECTIVE SLEEVE OF THE HARNESS THROUGH THE SQUARE CUT OUT ON THE SMALL PERFORATED METAL COVER.

·USING TWO (2) SMALL SCREWS (NO.4) SECURE, THROUGH THE ELONGATED HOLES, THE SMALL FRONT COVER TO THE TOP OF THE TOP COVER, PUSH THE SMALL COVER AGAINST THE BOTTOM PART OF THE CAGE AND SECURE IT WITH TWO (2) LARGE SCREWS (NO.8) TO THE SIDE WOOD PANEL.

ATTACH ONE END OF THE 36 INCH LONG GREEN GROUND WIRE, SUPPLIED WITH THIS KIT, UNDER ANY OF THE SCREWS USED TO SECURE THE CAGE, CONNECT THE OTHER END OF THE GREEN WIRE TO EARTH GROUND, E.G. POWER SUPPLY CHASSIS OR TV MONITOR CHASSIS.

P.C. BOARD ASSEMBLY:

THE COMPUTER BOARD IN THIS KIT OPERATES MOST EFFICIENTLY AND RELIABLY WHEN THE POWER SUPPLY IS SET SO THE VOLTAGE ON THE BOARD IS +5.0 VOLTS, ± 0.1 VOLT. TO CHECK THIS, PLACE A METER ACROSS +5 VOLTS (PIN-V) AND GROUND (PIN-U), AT THE EDGE CONNECTOR. ADJUST, IF NECESSARY, THE +5 VOLT CONTROL ON THE POWER SUPPLY.

THE P.C. BOARD METAL CAGE SUPPLIED WITH THIS KIT MUST BE USED AND TERMINATED TO EARTH GROUND AT THE TIME OF INSTALLATION.

POWER SUPPLY:

THE POWER SUPPLY MUST PROVIDE +5 VOLTS, 6.0 AMPS AND +12 VOLTS, 2.0 AMPS CURRENT PARAMETERS. ALL OUTPUT SOURCE VOLTAGES MUST BE STABLE FOR INPUT LINE VOLTAGE VARIATIONS OF FROM 90 TO 132 VOLTS A.C.

CHECKING YOUR GAME:

SET THE DIP SWITCHES ON THE P.C. BOARD TO THE DESIRED SETTINGS, REFER TO THE OPTIONAL DIP SWITCH SETTINGS CHART IN THIS MANUAL, AND APPLY POWER TO THE GAME.

CHECK THE VIDEO DISPLAYED ON THE TV MONITOR. IF NO VIDEO IS PRESENT, UNPLUG THE GAME AND CHECK THE POWER SUPPLY FOR PROPER OUTPUT VOLTAGES (REFER TO P.C. BOARD ASSEMBLY SECTION ABOVE). CHECK, ALSO, THE MONITOR CONNECTORS FOR OPEN OR SHORTED CIRCUITS.

IF THE VIDEO DISPLAYED IS UPSIDE DOWN, CHECK THE SETTING OF THE DIP SWITCH FOR UPRIGHT OR TABLE TYPE SELECTION.

IF THE SWITCH SETTING IS CORRECT, UNPLUG THE GAME AND INVERT THE MONITOR YOKE 90° BY UNSOLDERING, REVERSING AND RESOLDERING THE TWO INSIDE WIRES LEADING FROM THE MONITOR CIRCUIT BOARD TO THE YOKE. REPEAT THE SAME PROCEDURE WITH THE TWO OUTSIDE WIRES LEADING FROM THE MONITOR CIRCUIT BOARD TO THE YOKE.

REFER TO TV MONITOR YOKE ILLUSTRATION DRAWING IN THIS MANUAL.

TV MONITOR SYNCHRONIZATION ("SYNC")

THE P.C. BOARD ASSEMBLY IN THIS KIT USES COMPOSIT NEGATIVE SYNCHRONIZATION.

THE WIRES OF THE NEW HARNESS TO THE MONITOR ARE COLOR CODED TO INDICATE THE "RED", "GREEN" AND "BLUE" VIDEO SIGNALS TO THE MONITOR. THE BLACK WIRE IS USED FOR GROUND AND THE WHITE IS FOR SYNCHRONIZATION.

ON WELLS/GARDNER TYPE MONITORS, ATTACH THE WIRES FROM THE P.C. BOARD TO THE MONITOR'S MAIN CIRCUIT BOARD AS SHOWN BELOW.

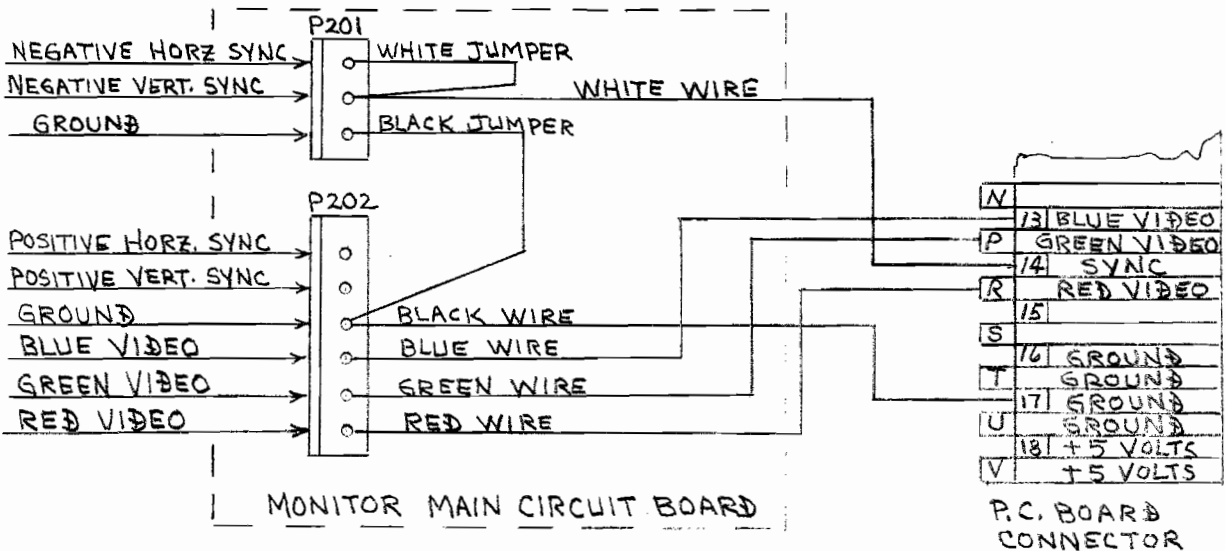

ON ELECTROHOME TYPE MONITORS, ATTACH THE WIRES FROM THE P.C. BOARD TO THE MONITOR'S MAIN CIRCUIT BOARD AS SHOWN BELOW.

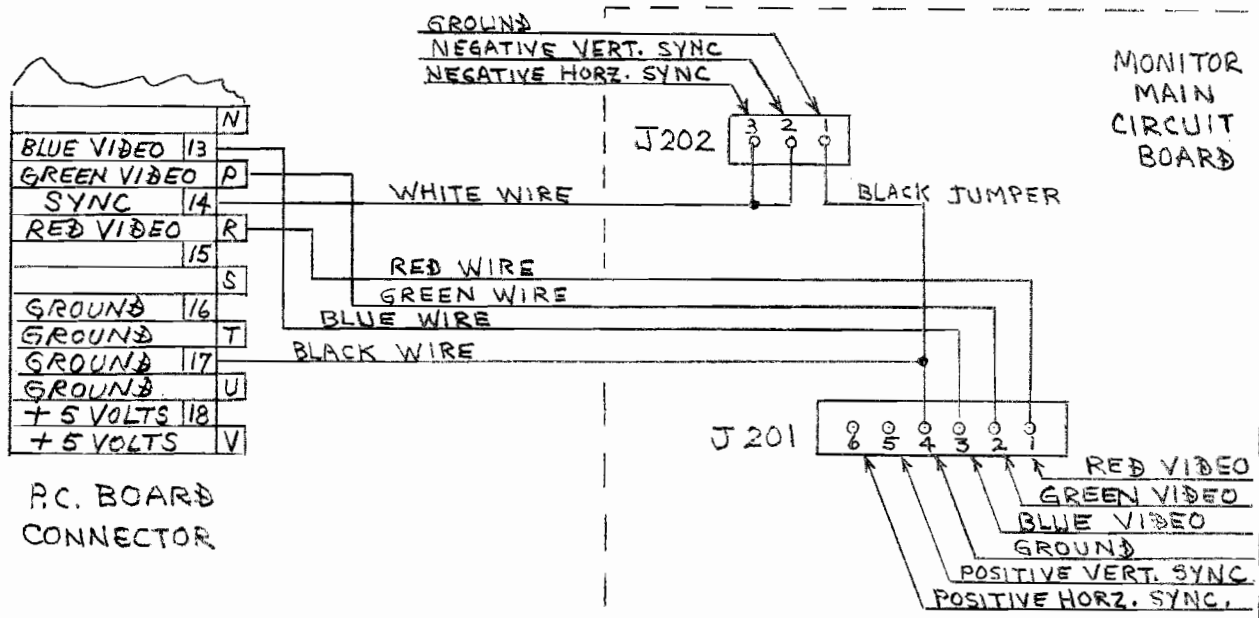

MONITOR ADJUSTMENTS MAY BE NECESSARY TO ADJUST THE PICTURE ON THE SCREEN. IF MONITOR ADJUSTMENT CAN NOT CORRECT PICTURE ROLL OR JITTER RE-CHECK THE WIRES LEADING TO THE "SYNC" CIRCUIT OF THE MONITOR. BE SURE THE WHITE WIRE IS CONNECTED TO THE NEGATIVE VERTICAL AND/OR HORIZONTAL COMPOSITE "SYNC" CIRCUIT.

P.C. BOARD DIAGNOSTIC TEST:

AUTOMATIC SELF TEST: THE P.C. BOARD SYSTEM WILL AUTOMATICALLY TEST ROMS AND RAMS UPON POWER ON. THE SCREEN WILL EITHER DISPLAY A "BAD" OR "OK" CONDITION AS FOLLOWS:

RAM 1 OK

RAM 2 OK

RAM 1 BAD

RAM 2 BAD

ROMS 11c, 11d, 12A, 12c, AND 12D WILL EITHER DISPLAY "OK" OR "BAD".

MANUAL TEST: A MANUAL TEST MAY BE PERFORMED BY DEPRESSING THE ONE AND TWO PLAYER START BUTTONS DURING POWER-UP. WHEN THE "CROSS-HATCH" PATTERN APPEARS, RELEASE THE BUTTONS AND PROCEED AS FOLLOWS:

- A. "CROSS-HATCH" PATTERN- WHEN THE "CROSS-HATCH" PATTERN IS DISPLAYED, ADJUSTMENT TO THE MONITOR MAY BE MADE TO CENTER AND/OR EXTEND THE BORDERS OF THE PICTURE.
- B. SWITCH TEST- FROM "CROSS-HATCH" PATTERN, PRESS ONE PLAYER START BUTTON AND THE SCREEN WILL DISPLAY ALL SWITCHES WITH A ZERO (0) TO THE RIGHT. THE ZERO (0) SHOULD CHANGE TO ONE (1) WHEN EACH SWITCH IS ACTIVATED.
- C. COIN COUNTER TEST- FROM SWITCH TEST, PRESS ONE PLAYER START BUTTON AND THE SCREEN WILL DISPLAY "COIN COUNTER"
- D. DIP SWITCH SETTINGS- FROM COIN COUNTER TEST, THE SCREEN WILL AUTOMATICALLY DISPLAY ALL PROGRAMMABLE FEATURES WITH THEIR RESPECTIVE SETTINGS. SETTINGS SHOULD CORRESPOND TO THE POSITION OF THE DIP SWITCHES ON THE P.C. BOARD.

TURN POWER "OFF" AND "ON", TO EXIT DIAGNOSTICS.

THE MATERIAL CONTAINED HEREIN IS CONFIDENTIAL AND NO PART OF IT CAN BE REPRODUCED WITHOUT THE EXPRESSED PERMISSION OF CENTURI, INC.

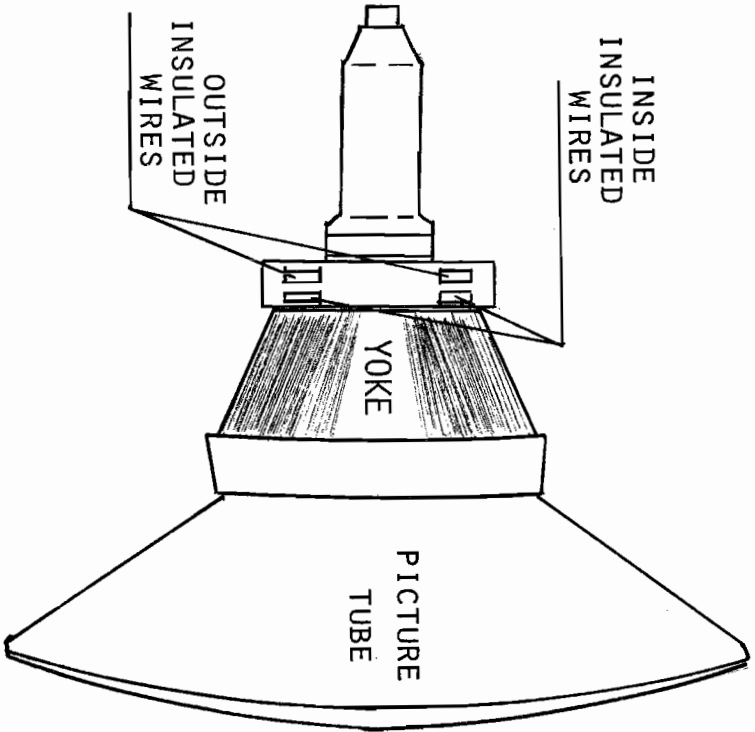

QC. APV/D	PROD. APV/D	QTY.	ASSEMBLY NO

REV. LET.		ECN NO.		REVISION		BY	
TOLERANCES Unless Otherwise Specified							
FRACTIONS	±	1/32					
DECIMALS 2 PL	±	.015					
DECIMALS 3 PL	±	.005					
HOLES	+	.003					
ANGLES	±	1/2°					
SHT. MET BENDS	±	2°					
NAME		centuri Inc.		HIALEAH, FLORIDA 33014			
TV MONITOR YOKE ILLUSTRATION		MATERIALS		HEAT TREAT.		FINISH	
DWN. MJ	APP'D. MJ	DATE 10-9-84	SCALE NONE	PART NO.	REV.		

OPTIONAL DIP SWITCH SETTINGS

DIP SWITCH NO.1 (8P DIP SWITCH)

COIN-1 SWITCH SETTINGS

COIN	PLAYS	SW1	SW2	SW3	SW4
1	1	OFF	OFF	OFF	OFF
1	2	ON	OFF	OFF	OFF
1	3	OFF	ON	OFF	OFF
1	4	ON	ON	OFF	OFF
1	5	OFF	OFF	ON	OFF
1	6	ON	OFF	ON	OFF
1	7	OFF	ON	ON	OFF
2	1	ON	ON	ON	OFF
2	3	OFF	OFF	OFF	ON
2	5	ON	OFF	OFF	ON
3	1	OFF	ON	OFF	ON
3	2	ON	ON	OFF	ON
3	4	OFF	OFF	ON	ON
4	1	ON	OFF	ON	ON
4	3	OFF	ON	ON	ON
FREE PLAY		ON	ON	ON	ON

COIN-2 SWITCH SETTINGS

COIN	PLAYS	SW5	SW6	SW7	SW8
1	1	OFF	OFF	OFF	OFF
1	2	ON	OFF	OFF	OFF
1	3	OFF	ON	OFF	OFF
1	4	ON	ON	OFF	OFF
1	5	OFF	OFF	ON	OFF
1	6	ON	OFF	ON	OFF
1	7	OFF	ON	ON	OFF
2	1	ON	ON	ON	OFF
2	3	OFF	OFF	OFF	ON
2	5	ON	OFF	OFF	ON
3	1	OFF	ON	OFF	ON
3	2	ON	ON	OFF	ON
3	4	OFF	OFF	ON	ON
4	1	ON	OFF	ON	ON
4	3	OFF	ON	ON	ON
FREE PLAY		ON	ON	ON	ON

OPTIONAL DIP SWITCH SETTINGS

DIP SWITCH NO.2 (8P DIP SWITCH)

NUMBER OF MIKIES

NUMBER	SW1	SW2
3	OFF	OFF
4	ON	OFF
5	OFF	ON
7	ON	ON

GAME TYPE

STYLE	SW3
TABLE	OFF
UPRIGHT	ON

BONUS MIKIES

FIRST	EVERY	SW4	SW5
20,000	50,000	OFF	OFF
30,000	60,000	ON	OFF
30,000	----	OFF	ON
40,000	----	ON	ON

GAME LEVEL OF DIFFICULTY

LEVEL	SW6	SW7
1 (EASY)	OFF	OFF
2	ON	OFF
3	OFF	ON
4 (HARD)	ON	ON

AUDIO ATTRACTION

AUDIO MODE	SW8
SOUND OFF	OFF
SOUND ON	ON

THE MATERIAL CONTAINED HEREIN IS CONFIDENTIAL AND NO PART OF IT CAN BE REPRODUCED WITHOUT THE EXPRESSED PERMISSION OF CENTURI, INC.

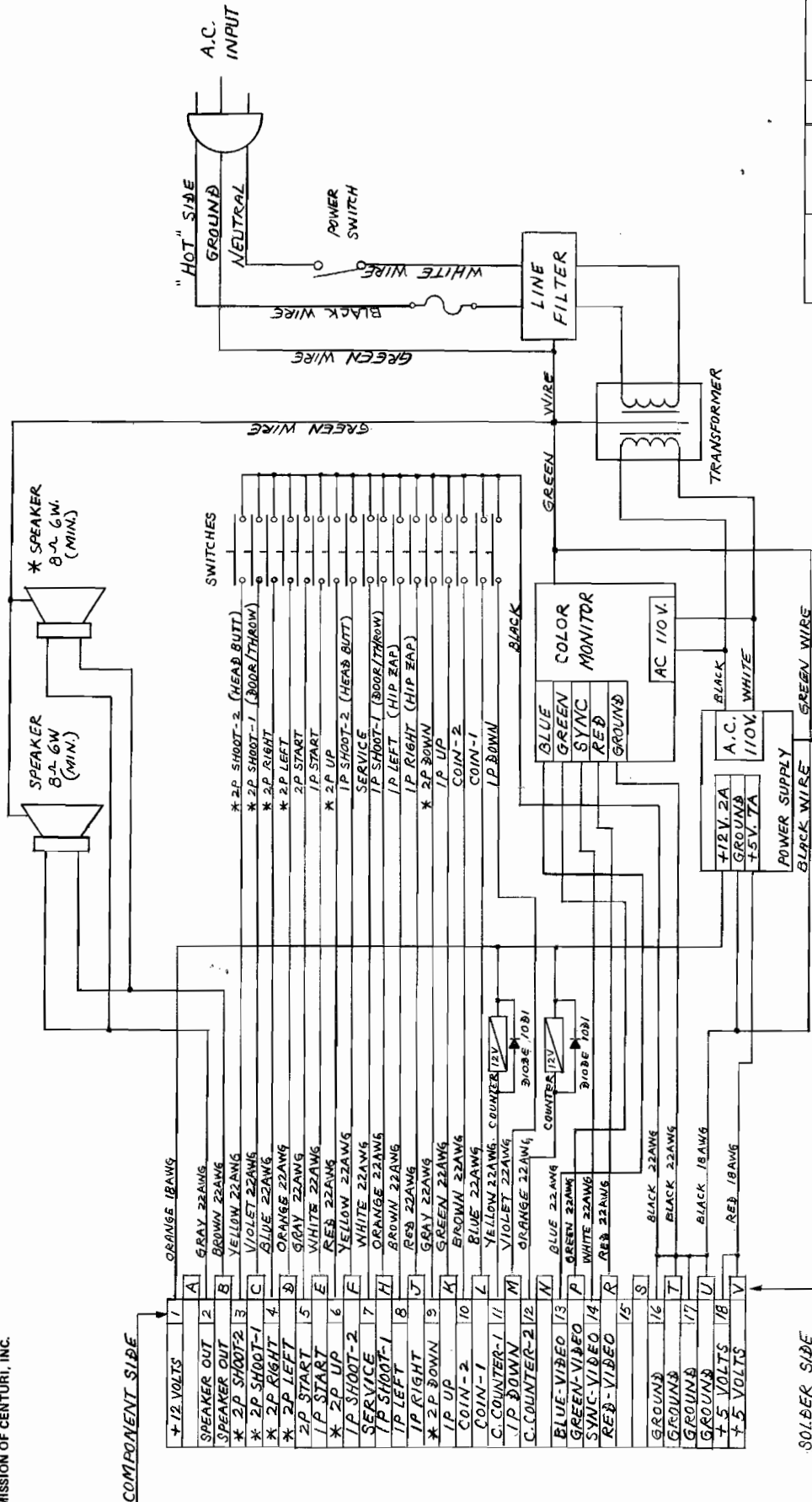

* NOTE -
* TABLE MODELS ONLY

REV. LET.	ECN NO.	REVISION	BY

TOLERANCES	
Unless Otherwise Specified	
FRACTIONS	± 1/32
DECIMALS 2 PL	± .015
DECIMALS 3 PL	± .005
HOLES	± .003
ANGLES	± .001
SHT. MET BENDS	± 1/2°

OC. APVD	PROD. APVD	QTY.	ASSEMBLY NO.

centuri ^{INC.}		HIALEAH, FLORIDA 33014	
NAME		GENERAL WIRING DIAGRAM - MIKIE	
MATERIALS		HEAT TREAT. FINISH	
APP'D.	DATE	SCALE	PART NO.
<i>[Signature]</i>	10-1-84	NONE	

centuriTM
INC.

CENTURI, INC. • P.O. BOX 1510 •
1780 WEST 4th AVE. • HIALEAH, FL 33011 - 1510
TELEPHONE: 305-558-5200 • TELEX: 803694 •
FAX: 305-557-3611 • ANSB CENTURI •
SALES DEPT.: 305-558-6200
SERVICE: 1-800-327-7710