

~~~~~  
~~~~~  
~~~~~  
~        Owners Manual for NATO DEFENSE        ~  
~~~~~  
~~~~~

Pacific Novelty Manufacturing  
Customer Service Department  
4094 Glencoe Avenue  
Marina Del Rey, Ca. 90291  
(213) 822-0399

\* No part of this document may be reproduced or disclosed  
except with the prior written approval of PNM \*

(PL062182)

INDEX

|          |   |                                   |
|----------|---|-----------------------------------|
| PART I   | - | QUICK REFERENCE CHART OF SETTINGS |
| PART II  | - | OPERATIONS MANUAL                 |
| PART III | - | DIAGNOSTICS                       |
| PART IV  | - | NOTICES                           |

-----  
 TOP LEFT DIP SWITCH  
 -----

1 2

-----  
 0 0 10,000 POINTS / BONUS TANK ; SOFTWARE VERSION: ;  
 1 0 20,000 POINTS / BONUS TANK ; 062182 ;  
 0 1 30,000 POINTS / BONUS TANK -----  
 1 1 40,000 POINTS / BONUS TANK

SWITCH 3 - ON = Disable Sound Demonstration in Attract mode

OFF = Enable Sound Demonstration in Attract mode

SWITCH 4 - ON = BONUS TANK FOR SCORES ABOVE

OFF = NO BONUS TANK FOR ANY SCORE

5 6 7 8 <- SWITCH NUMBERS

0 0 0 1 - BURN-IN TEST(1ST 2 DIGITS IN CHECKSUM=SOCKET#)

1 0 0 1 - COLOR BAR DISPLAY

0 1 0 1 - CROSS HATCH GRID

1 1 0 1 - CONTINUOUS COLOR MAP WRITES

0 0 1 1 - VIDEO RAM ADDRESS SELECT WRITES

1 0 1 1 - VIDEO BIT MOVE

0 1 1 1 - IO BOARD DRIVER TEST

1 1 1 0 - Display current options in effect

\*\*\* Close SLAM switch or turn off/on game for new test \*\*\*

\*\*\* DON'T FORGET TO TURN OFF 5,6,7 & 8 WHEN DONE!!!!!! \*\*\*

-----  
 TOP RIGHT DIP SWITCH  
 -----

1 2

5 6

-----  
 0 0 25 CENTS/GAME 0 0 EASY (LIBERAL)  
 1 0 50 CENTS/GAME 1 0 MEDIUM EASY  
 0 1 2 games/25 cents 0 1 MEDIUM HARD  
 1 1 1 game/25 3 games/50 1 1 HARD (CONSERVATIVE)

3 4

-----  
 0 0 3 TANKS/GAME SWITCH 7 if on then cocktail version  
 1 0 4 TANKS/GAME if off then upright version  
 0 1 5 TANKS/GAME  
 1 1 7 TANKS/GAME SWITCH 8 if on then Add-A-Coin feature  
 enabled.  
 if off then no Add-A-Coin

-----  
 SYMBOLS: X <-IGNORE ; 1 <-TURN ON (CLOSE) ; 0 <- TURN OFF (OPEN)  
 -----

Your NATO DEFENSE game incorporates a number of adjustments in order to control the time the player can tie up the machine. You can control the followings:

1. Number of tanks per game 3,4,5 or 7 tanks.  
We suggest 3 tanks per game
2. Bonus tank feature - at a selected score level  
We suggest you turn this feature on
3. Points needed for bonus tank.  
We suggest 10,000 points per bonus tank  
You can set it at 20,000 , 30,000 or 40,000 points.
4. Price per play.  
We suggest you follow your location policy as to price.  
you can select 25 or 50 cent play.

Controls used in the Game  
-----

The Player has the following controls:

Joystick - When moved in any of four directions, the player's tank will move in that direction. That is up, down, left, right. The Joystick contains four switches which are depressed by the movement of the control by the player.

One Player Start - Starts the single player game if an appropriate number of coins have been deposited.

Two Player Start - Starts the two player game if an appropriate number of coins have been deposited.

### Hardware Concepts

The same is composed of two circuit boards:

1. Processor board - Contains,
  - A. Microprocessor
  - B. Memories (RAM & ROM)
  - C. Video Generator
  - D. Control Logic
  
2. Interface Board - Contains,
  - A. Sound synthesizers
  - B. Switch input decoding
  - C. Option DIP switches
  
3. Coprocessor Board -
  - A. Proprietary logic to increase performance of Z80 for graphics functions.

The Processor board acts as the brains and display unit for the game. It contains a Z80 microprocessor and Read Only memories which contain the programming for the game. In addition the board contains the hardware for generating the color display seen by the player on the monitor. The control logic incorporated in the game allows for peripheral boards (Interface board) to communicate with the microprocessor.

A computer would not be of much use to anybody unless it could talk to 'the outside world'. The Interface Board serves this purpose. The boards acts as the 'eyes and ears' of the computer - scanning coin, start, joystick and other switch inputs and reporting their status to the computer. In addition to having 'eyes and ears' a game needs a mouth - sound. The board also serves as the generator of synthesized sounds via it's two PSG (programmable sound generators) and amplifiers. This game also incorporates a tape unit which supplies special sound effects. The board serves to control the following functions:

- 1: Supply power to tape Unit (Transistor switch).
- 2: Connect left channel to speaker (relay contacts).
- 3: Connect right channel to speaker (relay contacts).

The tape unit is an automotive type stereo unit which contains an cassette recorded by PNM. The Interface Unit takes care of all the needs of the recorder, turning it on and off and 'cueing' the individual tracks to the outside world as required.

Game Set-Up on Location  
-----

Before placing the same on location you may want to reconfigure the same to suit the clients in your location.

To set up the sound, first start the game in the two player mode and then adjust Channels A,B and C. To adjust Channel D you will need to have someone play the game while you fiddle with the tape unit controls.

Sound -  
-----

The same incorporates four channels of sound. You may want to change the volumes of these channels - this is how you do it.

Channel A - (PSG) Warning tone: Adjust trimmer pot on interface board (Small Board hooked to large board) at

Location -> 7D  
-----

Channel B - (PSG) Mine explosion sound trimmer pot on interface board (Small Board hooked to large board) at

Location -> 7C  
-----

Channel C - Tank chatter sound coming from tape unit. On tape unit itself. Control the Master volume for Channels C and D by increasing the 'VOLUME' control on the tape unit itself. To make Channel C louder than D move 'BALANCE' control till the desired volume is obtained.

Channel D - Tank crash sound coming from tape unit. On tape unit itself. Control the Master volume for Channels C and D by increasing the 'VOLUME' control on the tape unit itself. To make Channel D louder than C move 'BALANCE' control till the desired volume is obtained.

Helpful Hints about your Game

There are a number of areas you should pay attention to in order to maximize your earnings from this game.

Care of the Color Monitor-

The primary display device for this game is the Color Monitor. When you receive your game, or move it around, you may find that the game has acquired what appears to be a case of multi-colored blotchy color areas. These are caused by stray magnetic fields which magnetize the tube and surrounding metal. We suggest that you 'desauss' your game with a desaussing coil. The coil is a large round electromagnet which plugs into the 110 volt line. Since the power line is AC it has the property of demagnetizing the parts near and on the monitor. Your distributor most likely has such a coil and will be able to instruct you in its use (if you need it at all). All controls on the monitor have been preset at the factory. If you change any of the controls you better know what you are doing!

Care of Tape Unit-

This game incorporates an leaderless autoreverse cassette which produces the chatter between tanks as well as the crashing sounds when the tanks are hit. We suggest that you pay particular attention to the maintenance of this unit. If you find that the Stereo unit is functional (try playing a regular tape in it), yet the leaderless cassette doesn't play, you may have a damaged or worn out tape (under normal use (?) these tapes have a lifetime of over two(2) years). You may purchase from PNM, a replacement for your original tape.



#### Care of Player Controls-

The pushbutton parts used in the front panel of the game can be directly cross-referenced to WICO replacements. The leaf switches are gold plated and may be cleaned with an ordinary piece of paper rubbed between the two surfaces. An ordinary point adjusted may be used to set the spacing. The Joystick should be aligned so that it is sensitive for deflection in 4 directions.

#### Coin Door -

The list of things that can be done to a coin door is unbelievable. If the mech fails to accept coins after months of service we suggest you clean it (Who's buried in Grant's Tomb?). The door incorporated a slam switch which is NORMALLY OPEN. To test the operation, kick the door and watch for a game reset. The slam switch erases ALL credits (sorry Charlie!).

#### Cabinet Levelers -

The cabinet is shipped with levelers used to make the game level (logical?). We strongly suggest that you install them to: A. Protect your floors from scratching; and B. To keep your players from waltzing your game across the floor.

#### TLC -

Treat your game with a lot of care and it will make bass and bass of quarters for you. Here at the factory we put a lot of care into the programming and building of the game to make the game a success. Keep the game working in top form and both you and the players will be happy cookies.

DIAGNOSTICS SECTION III

# DIAGNOSTICS SECTION III

```
*****
*****
*****
*****
***** *   DIAGNOSTIC   TEST   * *****
*****
***** PACIFIC NOVELTY MANUFACTURING *****
*****
*****
*****
*****
```

The Rom test set supplied allows the technician to test the electronics package in the NATO DEFENSE game.

- 
1. DIAGNOSTICS ARE ENABLED WHEN SWITCH 8 IS ON -  
(THE BOTTOM MOST AND LEFT SWITCH).
  2. CLOSE SLAM SWITCH TO SIGNAL CHANGE OF DIAGNOSTICS SWITCH
- 

| 1 | 2 | 3 | 4 | 5 | 6 | 7 | 8 | <- SWITCH NUMBERS |                                                |
|---|---|---|---|---|---|---|---|-------------------|------------------------------------------------|
| X | X | X | X | 0 | 0 | 0 | 1 | -                 | BURN-IN TEST(1ST 2 DIGITS IN CHECKSUM=SOCKET#) |
| X | X | X | X | 1 | 0 | 0 | 1 | -                 | COLOR BAR DISPLAY                              |
| X | X | X | X | 0 | 1 | 0 | 1 | -                 | CROSS HATCH GRID                               |
| X | X | X | X | 1 | 1 | 0 | 1 | -                 | CONTINUOUS COLOR MAP WRITES                    |
| X | X | X | X | 0 | 0 | 1 | 1 | -                 | VIDEO RAM ADDRESS SELECT WRITES                |
| X | X | X | X | 1 | 0 | 1 | 1 | -                 | VIDEO BIT MOVE                                 |
| X | X | X | X | 0 | 1 | 1 | 1 | -                 | IO BOARD DRIVER TEST                           |
| X | X | X | X | 1 | 1 | 1 | 1 | -                 | (RESERVED FOR FUTURE USE) (SETTINGS)           |

## DIAGNOSTICS SECTION III

### BURN-IN Test Rom instructions

The Burn in test supplied to you contains the following tests:

- 1: Checksum of all roms in the system -  
Reports the condition of all ROMS on board.
- 2: Harness/Control/IO board Test sequence  
Displays the position of all switches in the system.
- 3: Dip Switch Display  
Shows the switch positions of the two dip switches on the IO board.
- 4: 2114 RAM test - Test the condition of the on board RAM.
- 5: 4116 RAM test - Test the display RAM.
- 6: Coprocessor test - Test various section of coprocessor

DIAGNOSTICS SECTION III

\* TYPICAL DISPLAY \*

06/21/82      <- Version of this ROM set

```

<CPU Checksums>      <CoP Checksums>
00    <ok>            B4=<ok>      <- CoProcessor EPROM test
02    <ok>            C4=<ok>
04    <ok>            D4=<ok>
06    <ok>            H4=<ok>
08    <ok>            J4=<ok>
10    <ok>            K4=<ok>
12    <ok>
14    <ok>

```

(Cocktail version)

```

. . . .
. . . .
. . . . <- These are the Dip Switches
. . . . <- . . . Open circuit __ Closed circuit
. . . .
. . . . 2114 ERR <- Bad 2114
. . . . 4116 ERR <- Bad 4116
. . . .

```

( Player 1 control) ( Player 2 control)



^            1 2 player start  
 Either fire button

Note that from time to time you may get a 4116 error message. Since the 4116 ic's are used in the video section, you can still have a very playable game with a small fraction of errors.

If you get any error messages in the lower left side of the screen, these are caused by problems with the Coprocessor board. Errors such as 'CNTXT ERR' or 'ADDR XLAT ERR' are Coprocessor generated. If you receive a large number of messages in the lower left hand side, you either have the power missing from the corocessor or else the 50 pin flat cable has come loose.

All errors besides 4116 are of a very serious nature and should be corrected immediately as they impair the earnings of the game.

## DIAGNOSTICS SECTION III

!!!!!!!!!!!!!!!!!!!!  
!!!! CAUTIONS !!!!  
!!!!!!!!!!!!!!!!!!!!

There are a number of dependences and limitations of this particular test rom.

1. The whole relam of tests depend on the existence of GOOD RAM in the lowest 1k sesement of memory.

2. The tests used for the detection of errors and the 2114 and 4116 tests are very limited in their scope and the ability to trace down subtle problems in these areas.

### CHECKSUMS

The first test (checksums) adds up the contents (numbers in ROM) and generates a checksum number. The Test Rom has a table of correct values and upon finding the correct value displays '<ok>' to indicate it found what it expected. In case it doesn't find the correct number it will display a four digit number (16 bit hexadecimal checksum found). In case you do set something other than the '<ok>' check you manual for any changes which may have been made to that rom since the production of the test rom.

### DIP SWITCHES

The Dip switch display provides you with a method of determining the position of the dip switches located on the IO (small) board. What you are seeing on the screen is the internal representation (as the computer sees them) of the dip switches on the IO board. This test is useful in determining the most low level operation of the IO board.

## PLAYER CONTROL DISPLAY

One thing that is most annoying is problems in the harness and the adjustment of switches. This test shows you the opening and closing of switches on the:

- A: Player 1 control panel
- B: Player 2 control panel
- C: Coin and slam switches
- D: Fire button

The dots (.) shown represent the identical switches and their correct positions on the front panel of the actual game. The only exception to this rule is on the Player 2 panel. In this case you will find that the positions used for the one and two player start have been replaced with the COIN and SLAM switches. The symbols (.) and (\*) represent the OPEN and CLOSED positions of the switches on the front panel.

## Theory of Operation

Imbedded in the base of the ROM0 rom is code which detects the existence of a Rom14. If it does find a rom in this position it checks for the proper contents at the beginning of the ROM14 and if they are correct, the system begins execution at beginning of ROM14 + 6.

## DIAGNOSTICS SECTION III

COLBAR - Color Bar display generator.

THIS routine generates a color bar pattern to test the operation of the video section. The test itself erases a byte to zero then writes to the selected plane of display memory.

You will find this routine especially useful for testing the Wait line back to the CPU as well as the timing of writes.

The following must be running for this test to operate:

- 1 CPU and select logic to RAM/ROM
- 2 CPU RAM



## DIAGNOSTICS SECTION III

### VIDSEL - Video Ram select writes

In this test we cause each of the Video RAM select lines to be selected. Each Video RAM is read and written to in sequence. This test is designed to check that the Video section is actually connected to the CPU section.

Use this test to check for the existence of /MRD + /MWR +/WAIT as well as the address lines leading to the Video RAMS and the signals internal to the video circuit. Each address line going to the Video RAMS is exercised as well. In addition the data written is incremented after each pass through the test.

The test will try to reset the Video Controller chip and then begin to read and write data to each of the address boundary location points 1,2,4...last significant address. These are the only locations which will be written to.

Sync your scope to the /OUT 0 select as this signals the start of a select sequence.

## DIAGNOSTICS SECTION III

### VIDBIT - Video bit Move

This routine generates a single bit write in each and every cell (byte) in the display memory. It is intended to detect stuck bits in individual Planes.

In the normal operation of this routine, you will see thirty two lines accross the screen. On each pass you will see the entire group move to the side one single cell. You will notice that the test repeats after every eight writes due to there being only eight bits to test per cell.

Since the memory is arranged to the processor as eight bit bytes and the internal representaion is as 4 bit pixels. You may be able to isolate the problem to whether the problem is of a 4 or 8 bit error pattern. - Internal to video or in the interface between the two.

This test requires that the CPU be functioning as well as the 2114 Ram section. Selects to these sections must of course be operating.

## DIAGNOSTICS SECTION III

### PSGTST - IO board driver test

#### Programmable sound generator and OUTPUT DRIVER test

In the Pss test, each channel of the pss is, in sequence frequency modulated at full volume.

After all the Pss's have been tested, the relays and transistor drivers are sequenced in order.

#### Sequence:

- 1 All units off
- 2 Tape power on  
Talk track on  
Coin meter power on
- 3 Explosion track relay on
- 4 Explosion track relay off  
Coin meter off  
Talking track relay off
- 5 Start at sequence number 1 again

While each of the above is going on, each of the 6 channels of the PSG's (3 channels per PSG) is being frequency modulated. This makes a sort of Whooop, Whooop, Whooop and pause sound. The frequency modulated sequence is carried out on the total of 6 channels supplied by the two PSG's.

## NOTICES IV

### WARRANTY

Pacific Novelty Manufacturing (PNM) warrants that it's circuit boards and parts are free from any defects in workmanship and materials under normal use and service, for a period of thirty (30) days from date of shipment. PNM also warrants it's television monitors (in games which use them) to be free from any defects in workmanship and materials under normal use and service, for a period of Thirty (30) days from date of shipment. No other of the Seller's products or parts therefor are warranted.

If the product described in this manual should fail to conform to this warranty, The seller's sole liability shall be, at its option, to repair, replace, or credit Buyer's account for such products which are returned to the Seller during the said warranty period provided that:

A) The Seller is promptly notified IN WRITING upon discovery by the Buyer, that said products are defective.

B) Such products are returned to the Seller's plant; and

C) Seller's examination of the said products discloses to the Seller's satisfaction that such alleged defects existed and were not caused by alteration, improper repair, installation, accident, misuse, improper testing or accident.

In NO event shall Seller be liable for incidental or consequential damages such as loss of profits, loss of use or any other such losses.

Except for any express warranty set forth in written contract between Seller and Buyer which contract supersedes the terms of this order, this warranty is expressed in lieu of all other warranties expressed or implied, including the implied warranties of merchantability and fitness for particular purpose, and of all other obligations or liabilities on the Seller's part, and it neither assumes, nor authorizes any other person to assume for the Seller any other liabilities in connection with the sale of products under this order.

## WARNING!

This equipment generates, uses and can radiate radio frequency energy. If not installed and used in accordance with the instruction manual - its use may result in interference with radio communication services. As temporarily permitted by regulations, it (the same) has not been tested for compliance (with the limits for class A computing devices) pursuant to sub part J of part 15 of F.C.C. rules, which are designed to provide reasonable protection against such interference. Operation of this equipment in a residential area is may cause interference - in which case, the user, at his own expense, will be required to take whatever measures may be required to correct the interference.

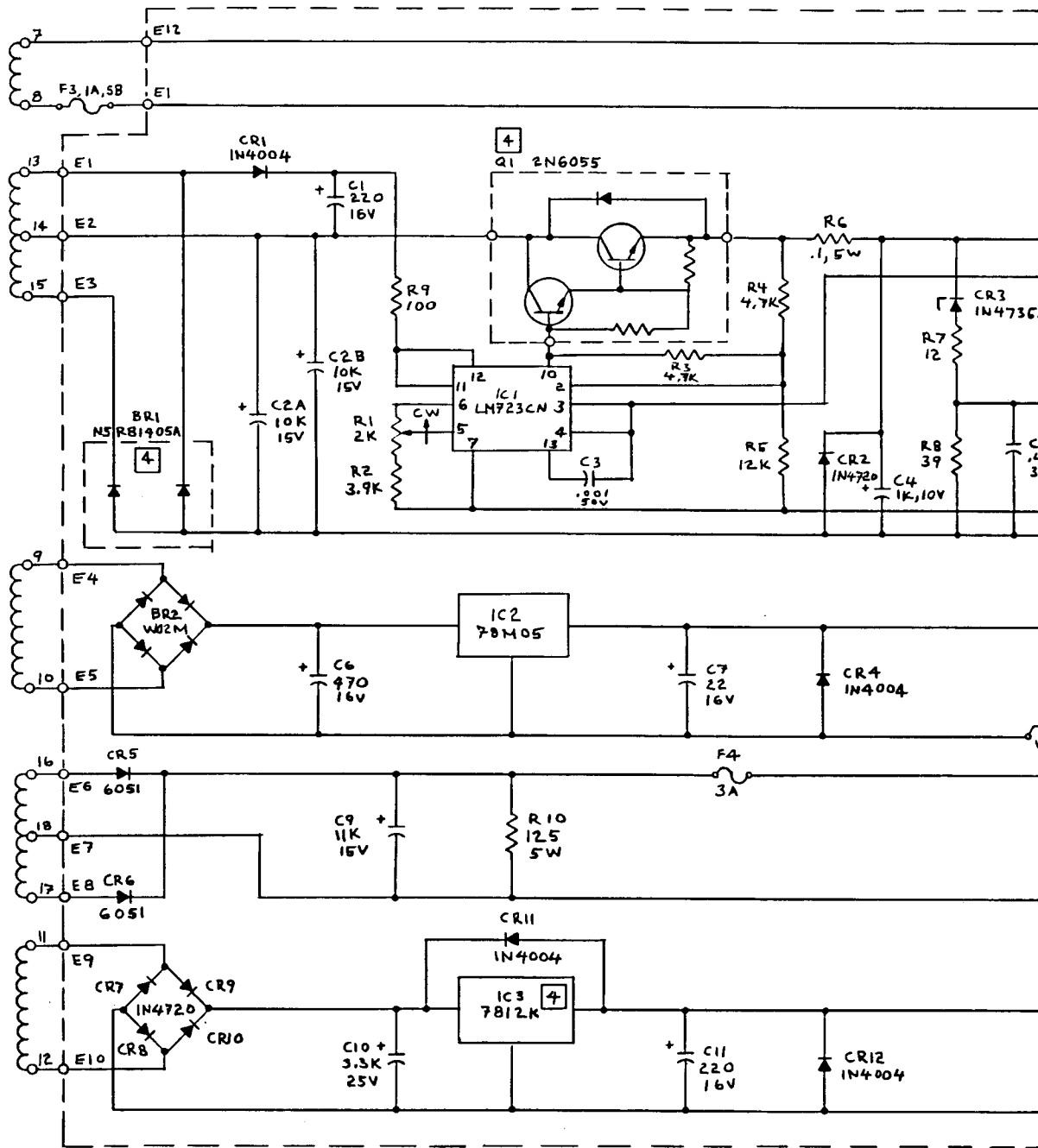

ENT MOUNTED ON CHASSIS.

RESISTANCE VALUES IN OHMS  $\pm 5\%$ ,  $\frac{1}{2}$ W.  
CAPACITANCE VALUES IN MICROFARADS.

UNLESS OTHERWISE SPECIFIED

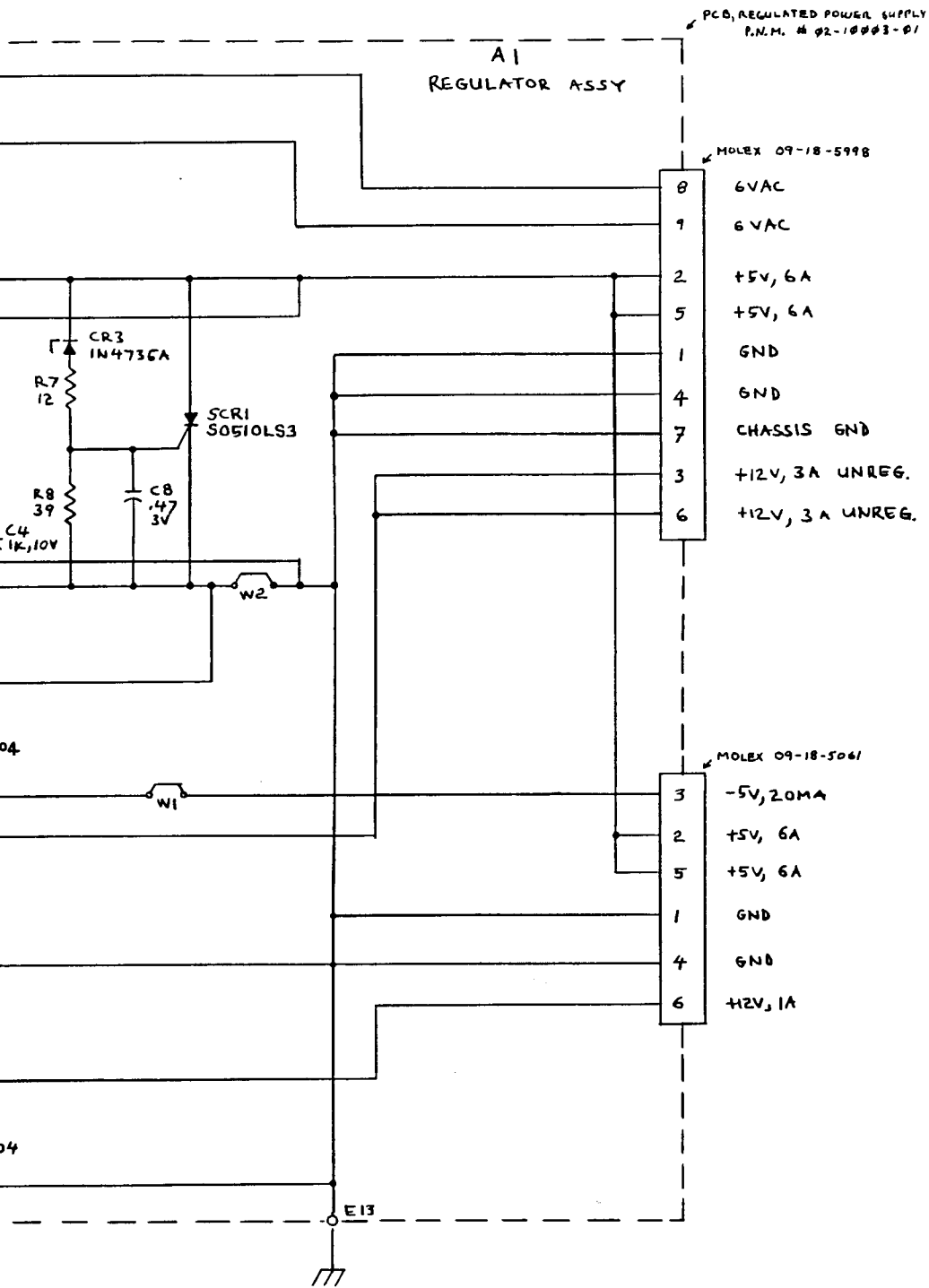

| REV. | DRAWN BY | DATE    | PACIFIC NOVELTY MANUFACTURING        |
|------|----------|---------|--------------------------------------|
| A    | A. J.    | 10-2-81 | MARINA DEL REY CA 90291              |
| B    | R.S.M.   | 5-12-82 | ASSY, PCB, REGULATED<br>POWER SUPPLY |
|      |          |         | REV. D P.N.M. # 05-10014-01          |
|      |          |         | SHEET 1 OF 1                         |

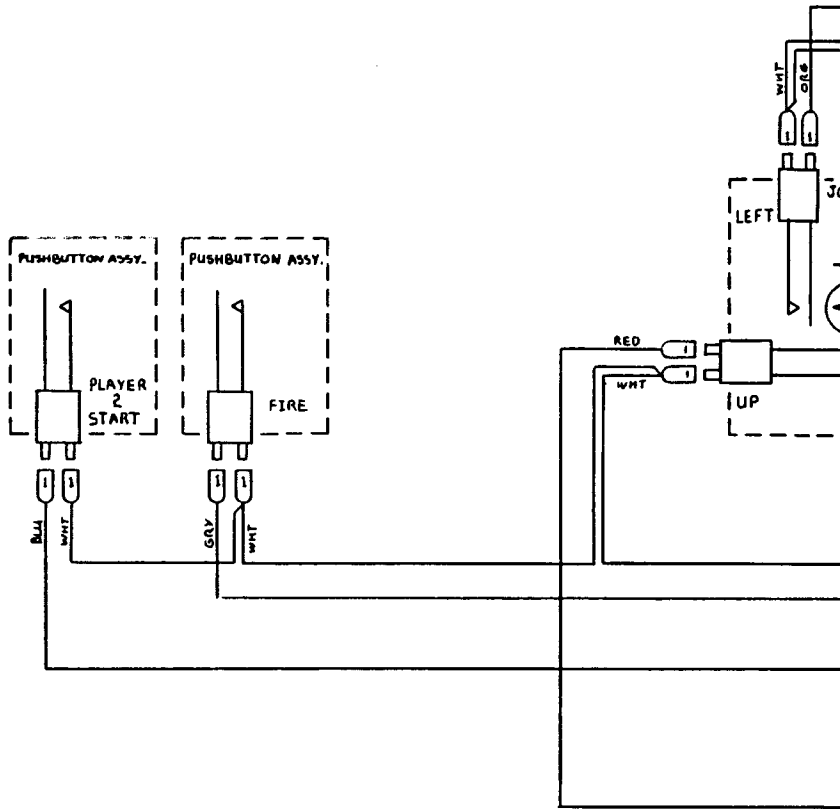



- ① USE .187 x .020 FASTON RECEPT. (20-24 AWG), FULLY INSULATED [QTY. PER ASSY. = 16]
- ② USE MOLEX Ø3-Ø9-2151 PLUG [QTY. PER ASSY. = 1]
- ③ USE MOLEX MALE Ø93 DIAM TERM. Ø2-Ø9-2136 [QTY. PER ASSY. = 7]
- ④ ALL WIRE USE 22 AWG, STRANDING 19x34, PVC INSULATION, 300V, 105°C COLOR AS INDICATED

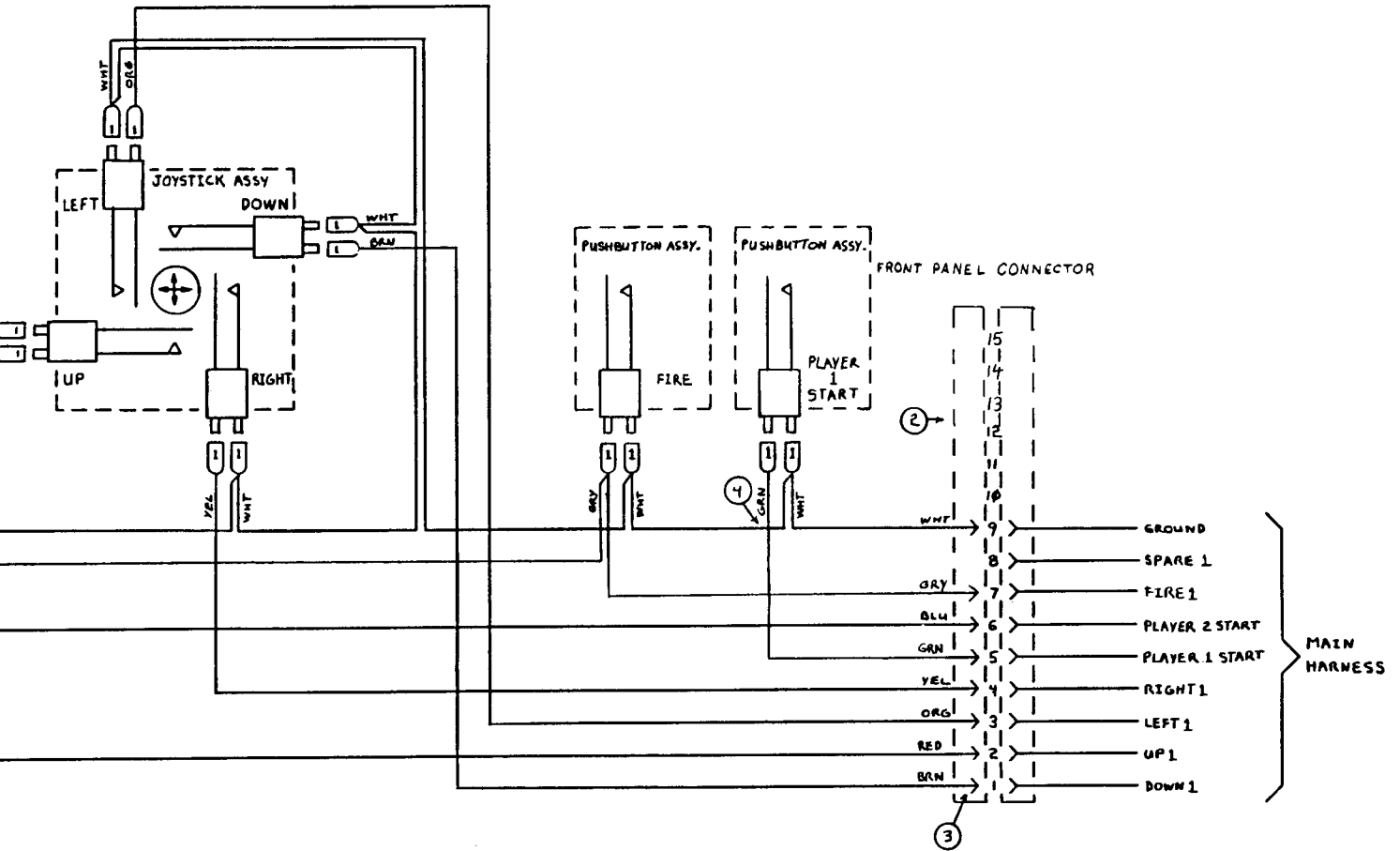

| REV. | DRAWN   | BY | PACIFIC NOVELTY MANUFACTURING, INC.<br>MARINA DEL REY, CA. ©1981 |
|------|---------|----|------------------------------------------------------------------|
| A    | 11/8/81 | ②  | Assy., Harness, Control Panel, Nato<br>05-10031-01               |
| B    | 2/17/82 | ④P |                                                                  |
| C    | 5/17/82 | ④  |                                                                  |
| D    | 6/22/82 | ④  |                                                                  |
|      |         |    | SHEET 1 OF 1                                                     |

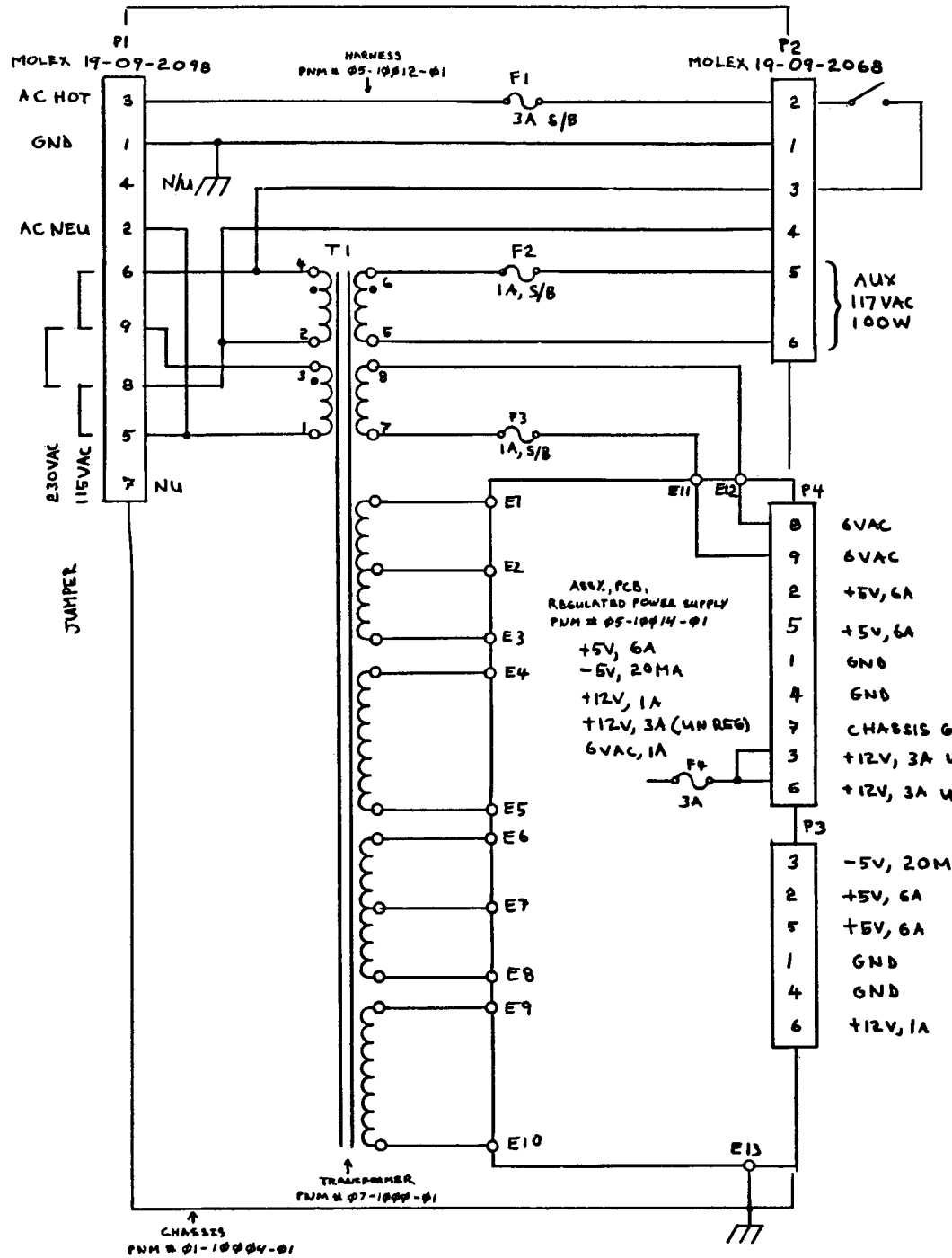

NOTES: UNLESS OTHERWISE SPECIFIED

2  
09-2068

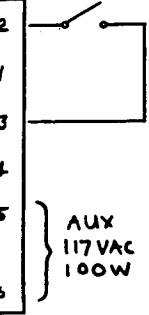

P4

- 3 6VAC
- 7 6VAC
- 2 +5V, 6A
- 5 +5V, 6A
- 1 GND
- 4 GND
- 7 CHASSIS GND
- 3 +12V, 3A UNREG
- 5 +12V, 3A UNREG

P3

- 3 -5V, 20MA
- 2 +5V, 6A
- 7 +5V, 6A
- 1 GND
- 4 GND
- 6 +12V, 1A

| REV. | DRAWN BY | DATE    | PACIFIC NOVELTY MANUFACTURING |                   |
|------|----------|---------|-------------------------------|-------------------|
| A    | A.T.     | 10-2-81 | MARINA DEL REY CA. 90291      |                   |
| B    | R.S.M.   | 5-12-82 | TITLE                         |                   |
|      |          |         | ASSY. REGULATED POWER SUPPLY  |                   |
|      |          |         | SIZE                          | PNM # 05-10016-01 |
|      |          |         | D                             |                   |
|      |          |         | SHEET 1 OF 1                  |                   |

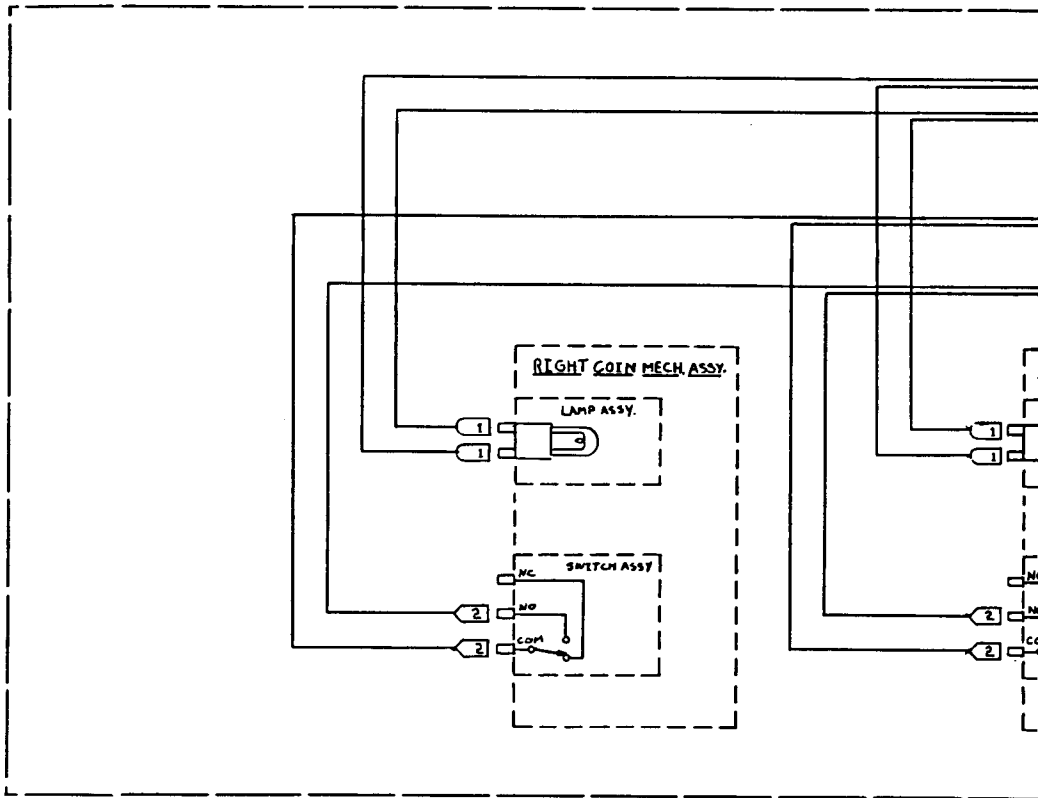

- ① USE .118" x .015" FASTON RECEPT. (20-24 AWG), FULLY INSULATED [QTY. PER ASSY. = 4]
- ② USE .250" x .032" FASTON RECEPT. (20-24 AWG), FULLY INSULATED [QTY. PER ASSY. = 4]
- ③ USE MOLEX 03-09-2092 PLUG [QTY. PER ASSY. = 1]
- ④ USE MOLEX 02-09-2136 MALE .093 DIAM. TERM. [QTY. PER ASSY. = 7]
- ⑤ WIRES JOINED WITH WIRE-NUT
- ⑥ SEMI-STRIP 1/2"
- ⑦ USE #6 STD SIZE RING TERMINAL
- ⑧ ALL WIRE; USE 22 AWG (19 x 34 STRANDING), PVC INSULATION COLORS AS INDICATED

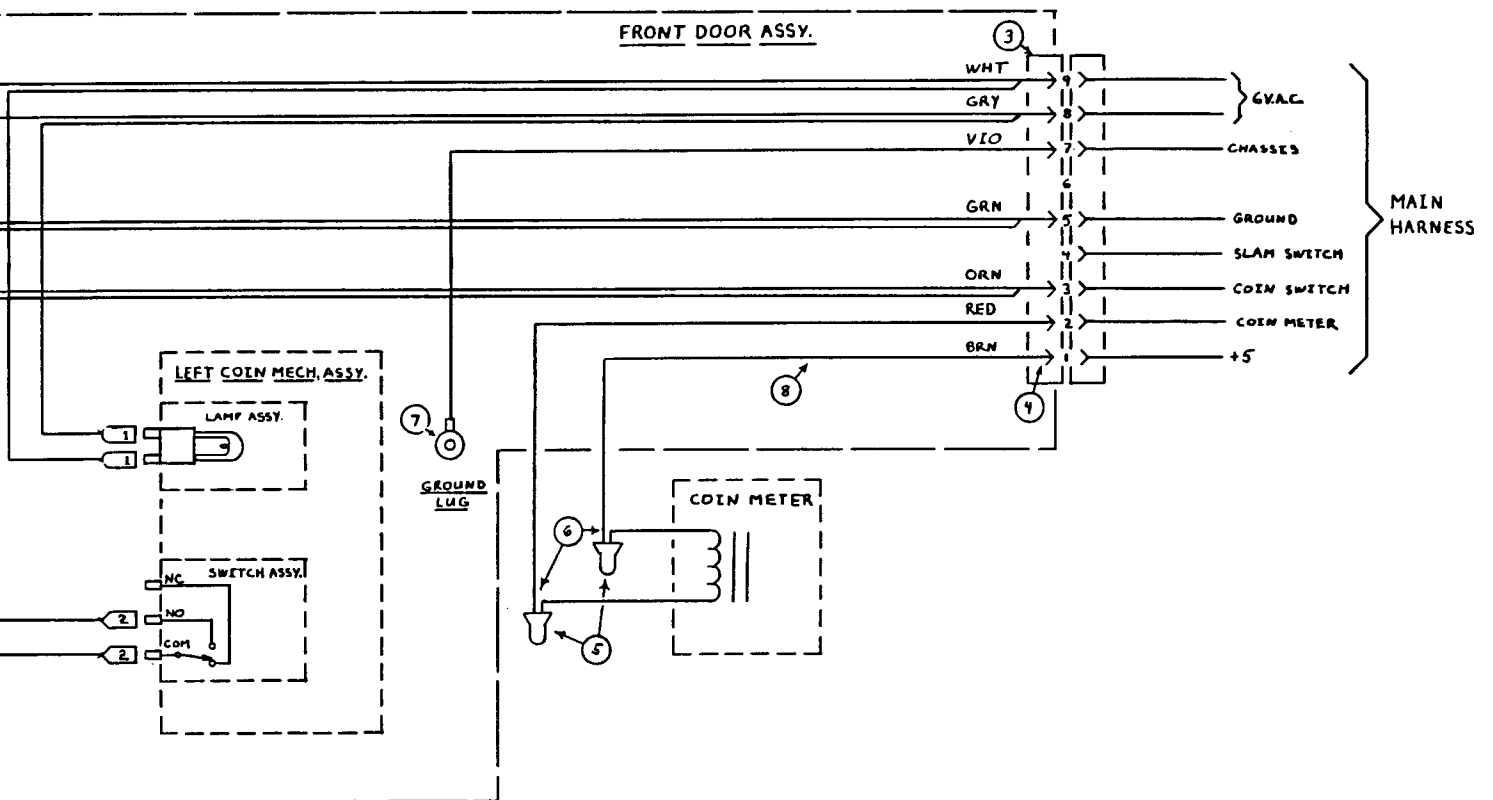

| REV. | DRAWN   | BY | PACIFIC NOVELTY MANUFACTURING, INC.<br>MARINA DEL REY, CA. ©1982 |
|------|---------|----|------------------------------------------------------------------|
| A    | 11/8/81 | ②  |                                                                  |
| B    | 2/17/82 | ②  | ASSY, HARNESS, COIN DOOR<br>(FOR COIN CONTROL "OVER-UNDER" DOOR) |
| C    | 3/22/82 | ②  |                                                                  |
| D    | 5/17/82 | ②  | 05-1005-01                                                       |





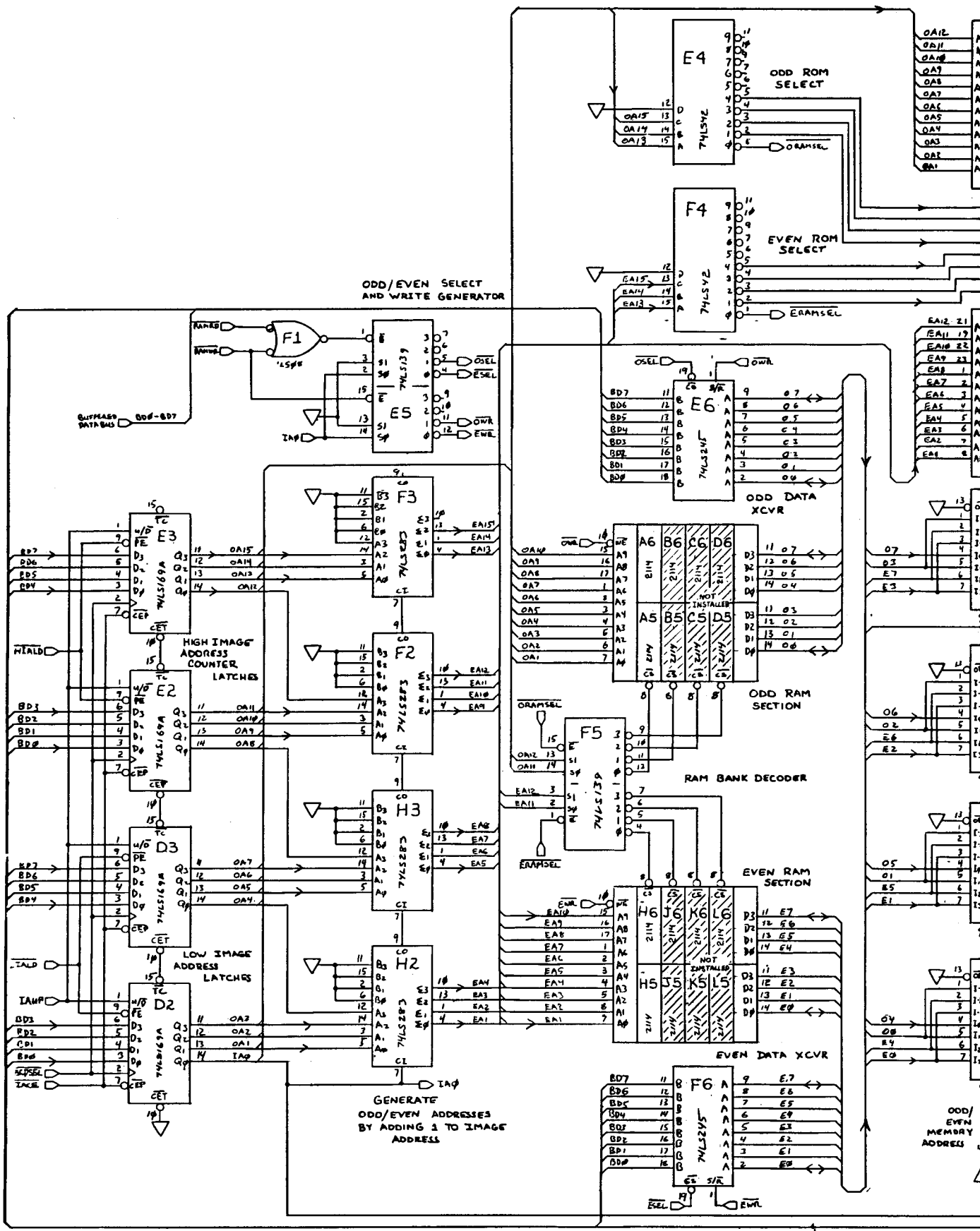

ODD/EVEN SELECT AND WRITE GENERATOR

OUTPASS DATA BUS ODP-OD7

F1

F2

F3

F4

F5

F6

E1

E2

E3

E4

E5

E6

HIGH IMAGE ADDRESS LATCHES

LOW IMAGE ADDRESS LATCHES

ODD RAM SECTION

EVEN RAM SECTION

RAM BANK DECODER

ODD DATA XCVR

EVEN DATA XCVR

GENERATE ODD/EVEN ADDRESSES BY ADDING 1 TO IMAGE ADDRESS

ODD/EVEN MEMORY ADDRESS



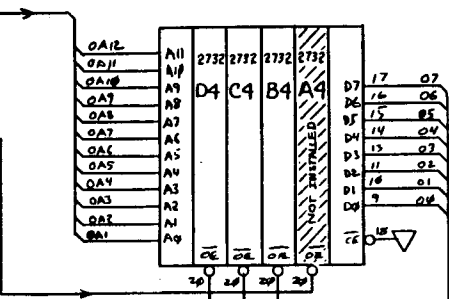

ODD-ADDRESS  
IMAGE ROM

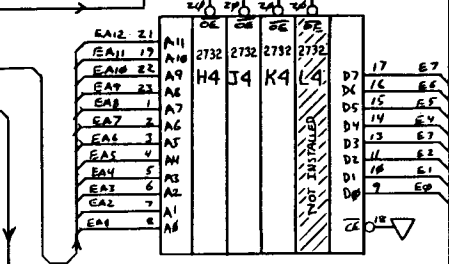

EVEN ADDRESS  
IMAGE ROM

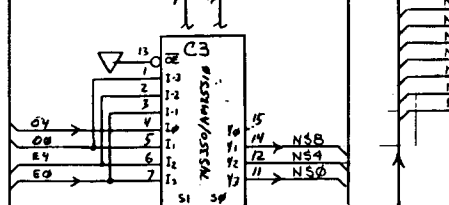
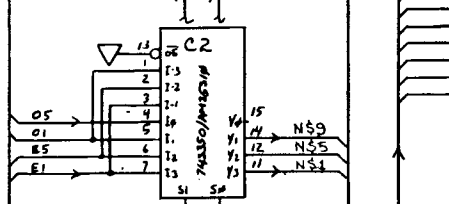
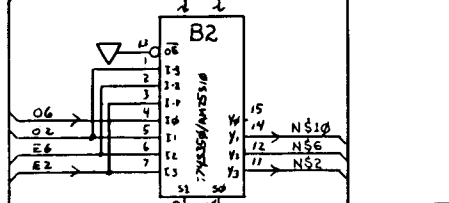
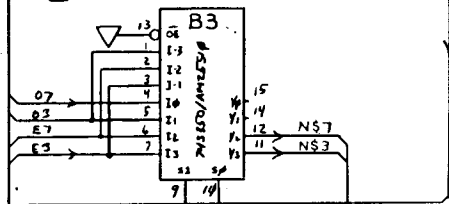

"N" SHIFT DATA  
INTERMEDIATE SIGNAL

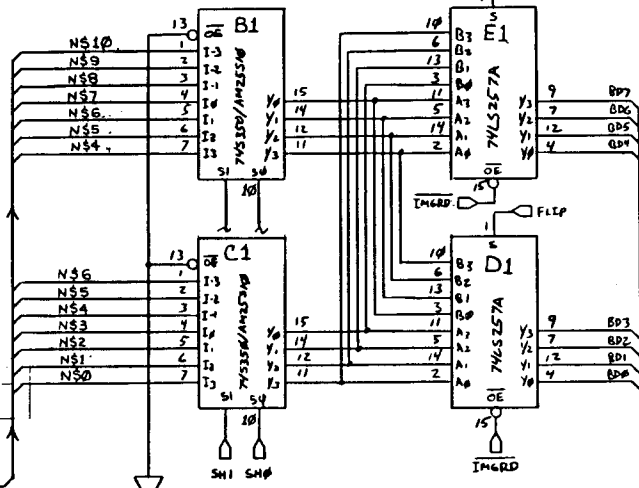

HIGH ORDER  
BARREL SHIFT  
UPPER/LOWER 4

LOW ORDER  
BARREL SHIFT  
1:4

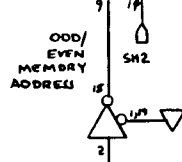

| REV | DRAWN    | BY             | PACIFIC NOVELTY MANUFACTURING  |
|-----|----------|----------------|--------------------------------|
| A   | 7/8/81   | R. [Signature] | Marina Del Rey, CA 90291 ©1981 |
| B   | 8/14/81  | [Signature]    | ASSY. PCB., NATO COPROCESSOR   |
| C   | 9/7/81   | [Signature]    | REV 0                          |
| D   | 12/16/81 | L. [Signature] | 05-10033-01                    |
| E   | 5/17/82  | [Signature]    |                                |
| F   | 7/24/82  | [Signature]    | SHEET 2 of 2                   |



ARE 48K TO GND  
SWN SWITCH ONLY

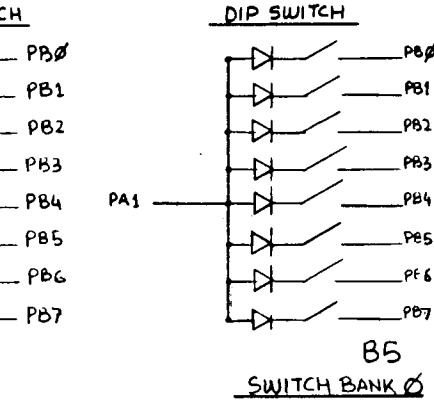

| REVISIONS |                              |          |                    |
|-----------|------------------------------|----------|--------------------|
| LTR       | DESCRIPTION                  | DATE     | APPROVED           |
| A         | PRODUCTION CHANGES           | 01 29 81 | <i>[Signature]</i> |
| B         | REVISE TITLE, ADD ASSY. NO.  | 5/17/82  | <i>[Signature]</i> |
| C         | CHANGE SWITCH INPUT LABELING | 6/22/82  | <i>[Signature]</i> |

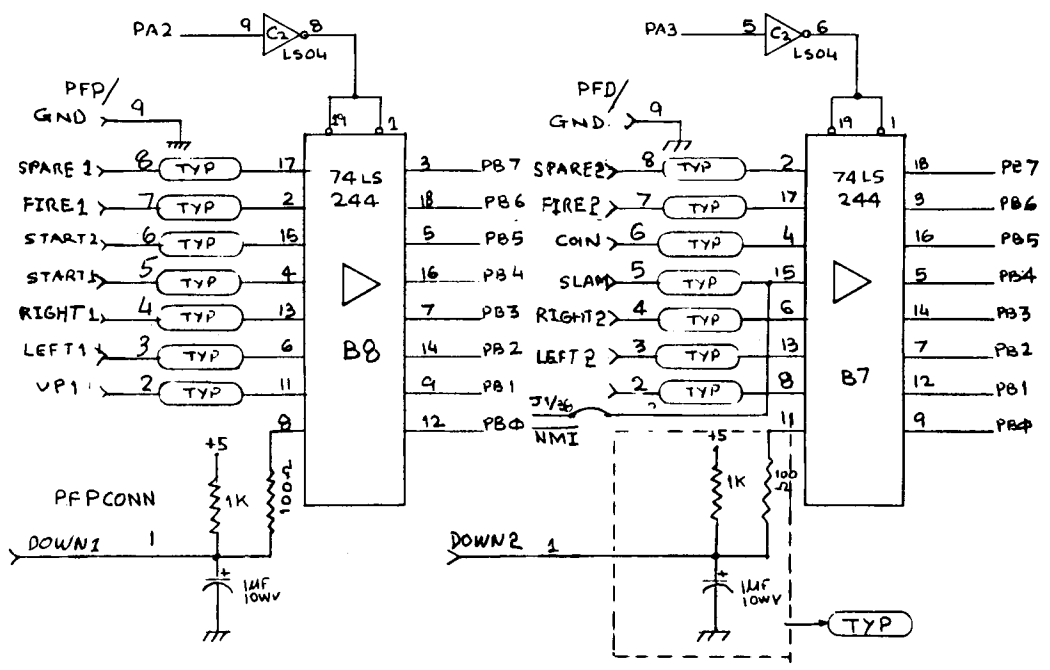
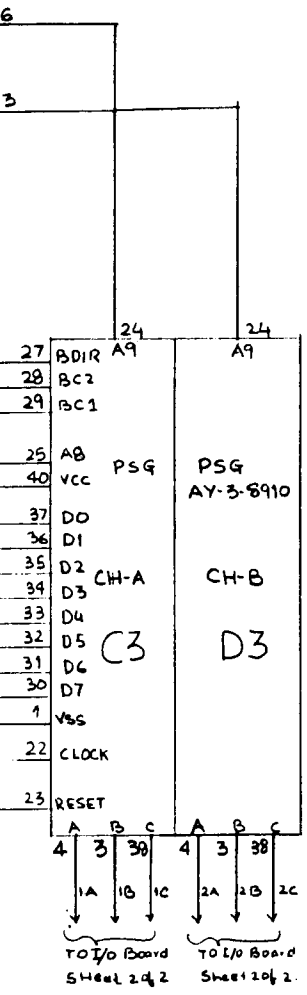
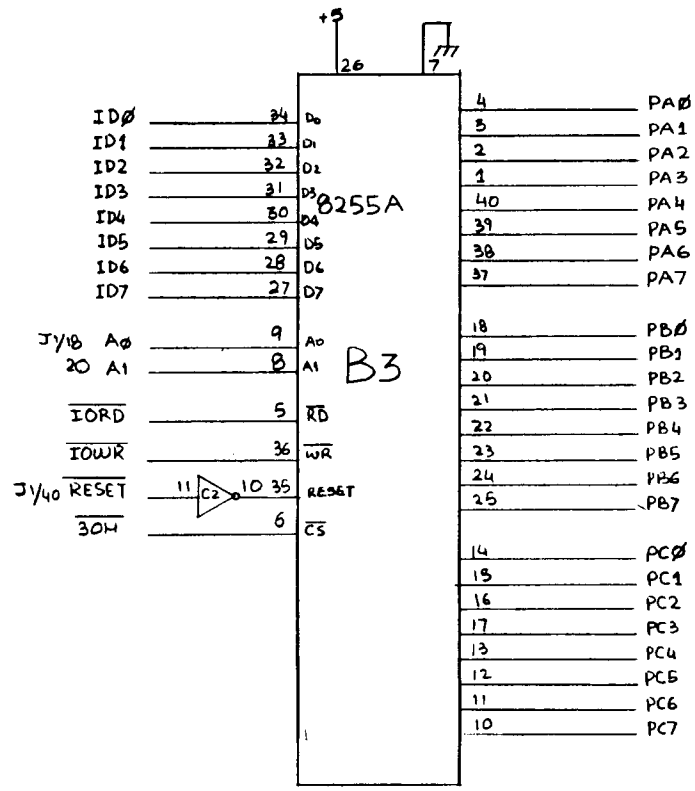

|                                       |          |                                 |                  |
|---------------------------------------|----------|---------------------------------|------------------|
| TOLERANCES UNLESS OTHERWISE SPECIFIED |          | PACIFIC NOVELTY MANUFACTURING   |                  |
| FRACTIONS DEC ANGLES                  | ± ± ±    | MARINA DEL REY, CA-90241        |                  |
| APPROVALS                             | DATE     | ASSY., P.C.B., I/O BOARD REV 2A |                  |
| DRAWN<br><i>[Signature]</i>           | 12/15/81 | 05-10034-01                     |                  |
| CHECKED                               |          | SCALE                           | SIZE<br><b>C</b> |
|                                       |          | DRAWING NO.                     |                  |
| DO NOT SCALE DRAWING                  |          | SHEET 1 OF 2                    |                  |

FROM PSC  
SHEET 1 OF 2

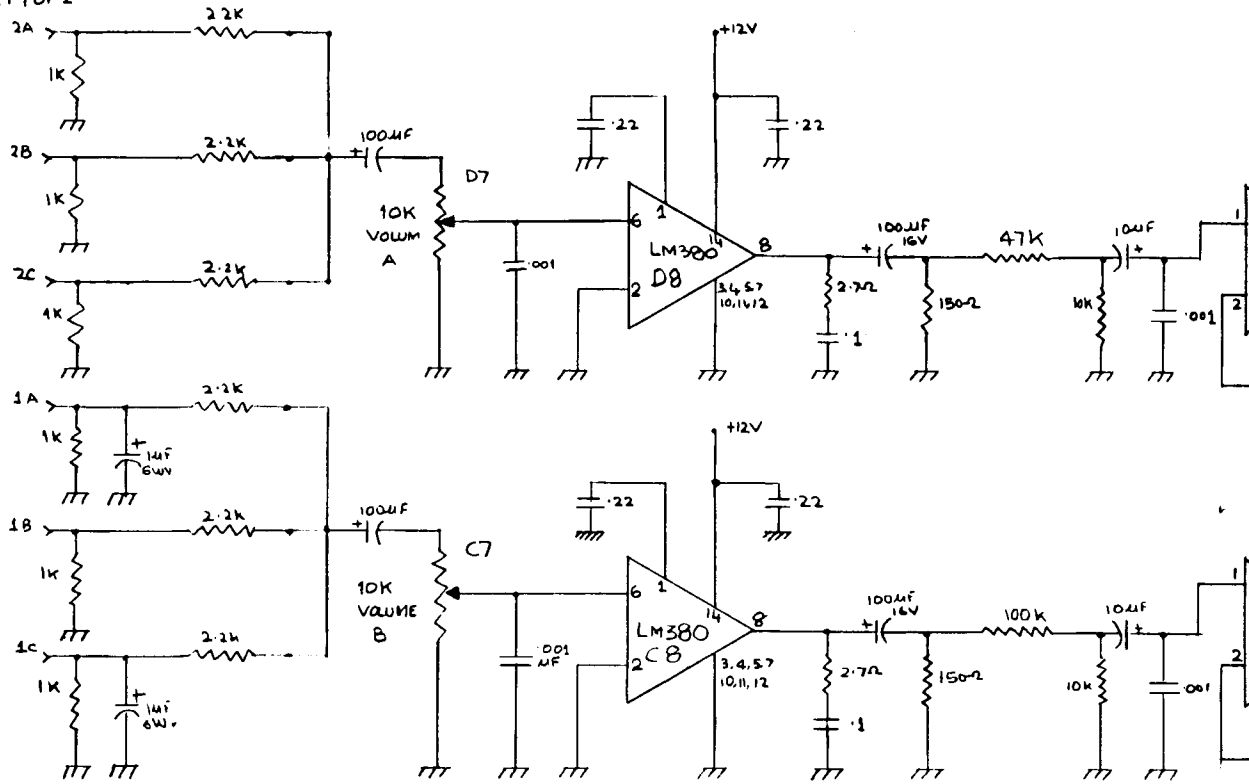

FROM  
B-3  
(8255)

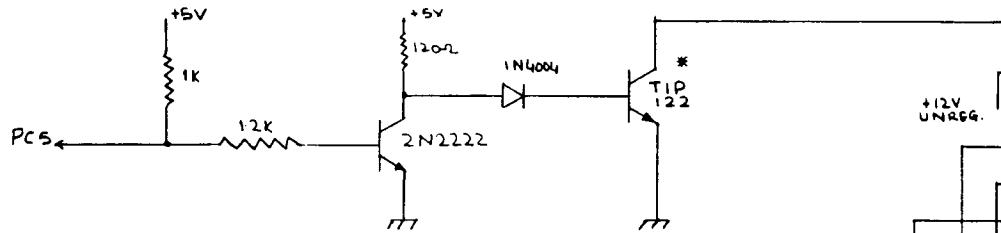

FROM  
B-3

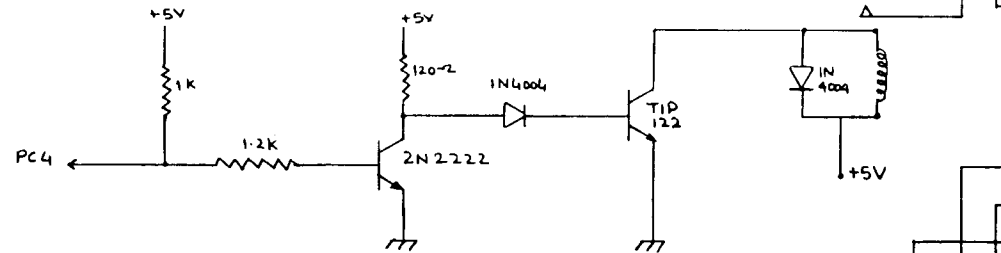

FROM  
B-3

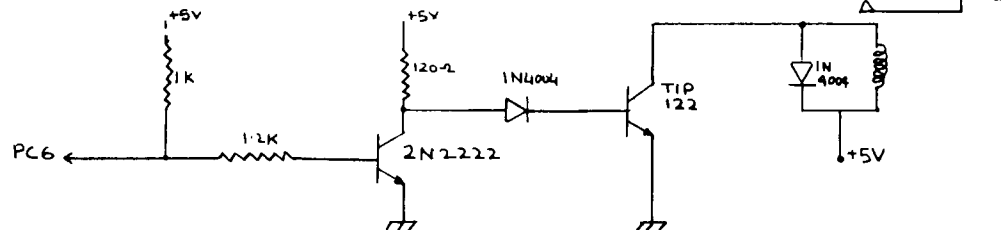

| REVISIONS |                              |          |                      |
|-----------|------------------------------|----------|----------------------|
| LTR       | DESCRIPTION                  | DATE     | APPROVED             |
| A         | PRODUCTION CHANGES           | 01/30/81 | 02/02/81 [Signature] |
| B         | CHANGE TITLE, ADD ASSY. NO.  | 5/17/82  | [Signature]          |
| C         | CHANGE SWITCH INPUT LABELING | 6/22/82  | [Signature]          |

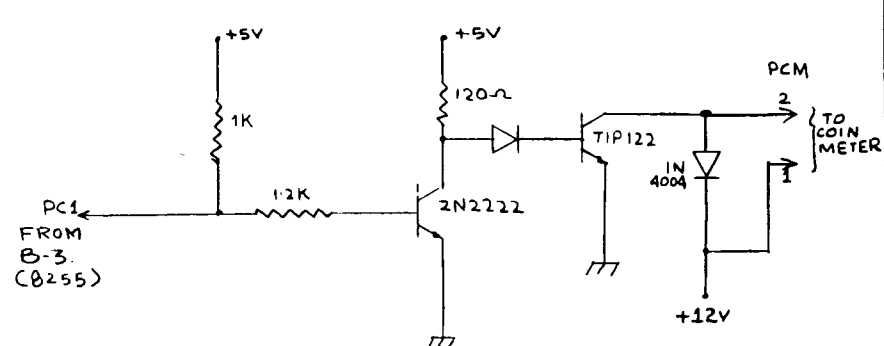
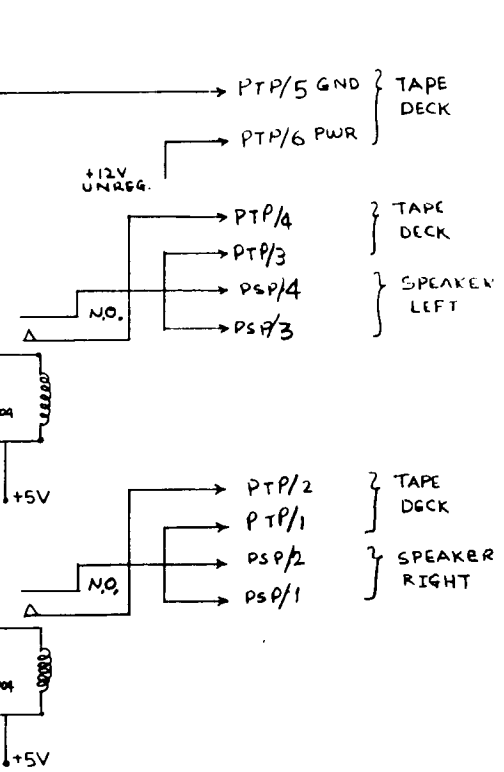
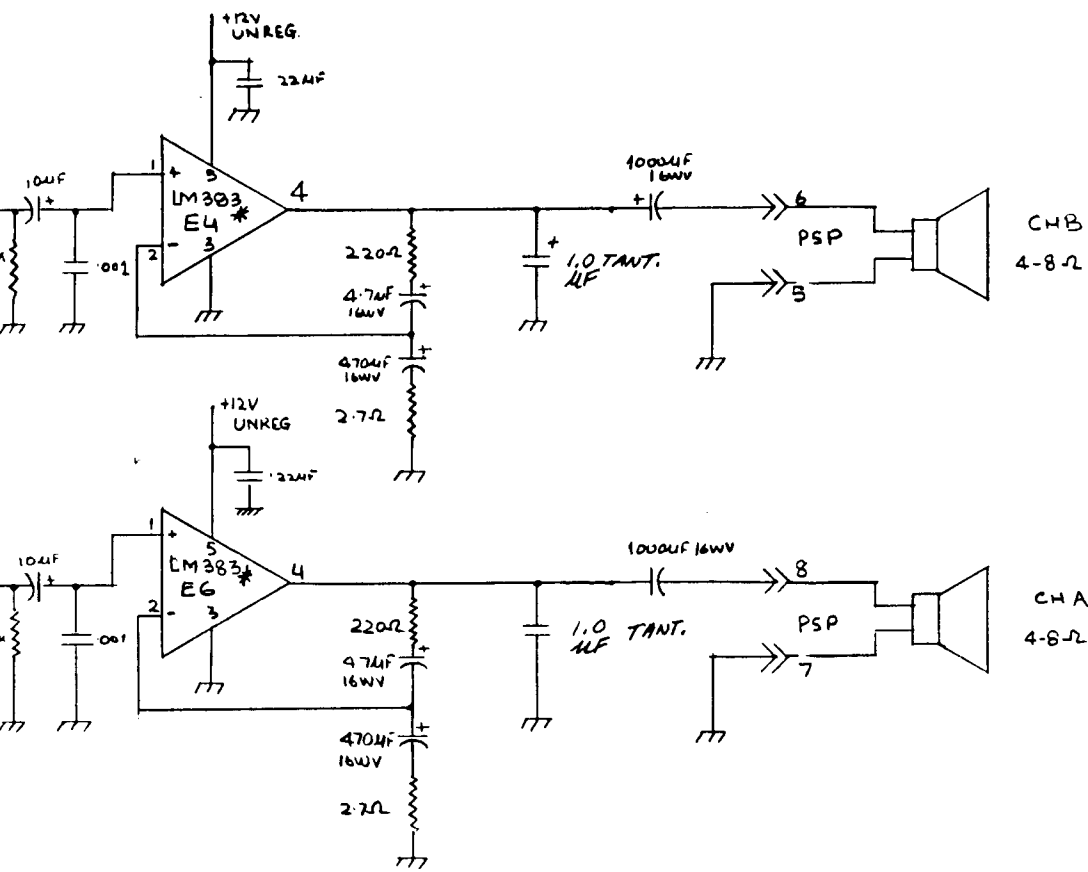

\* HEAT SINK

|                                       |          |                               |                  |
|---------------------------------------|----------|-------------------------------|------------------|
| TOLERANCES UNLESS OTHERWISE SPECIFIED |          | PACIFIC NOVELTY MANUFACTURING |                  |
| FRACTIONS DEC ANGLES                  |          | MARINA DEY REV, CA-90291      |                  |
| ±                                     | ±        | ASSY, PCB, I/O BOARD REV 2A   |                  |
|                                       |          | 05-10034-01                   |                  |
| APPROVALS                             | DATE     | SCALE                         | SIZE DRAWING NO. |
| DRAWN                                 | 12/15/81 |                               | C                |
| CHECKED                               |          |                               |                  |
| DO NOT SCALE DRAWING                  |          | SHEET 2 OF 2                  |                  |

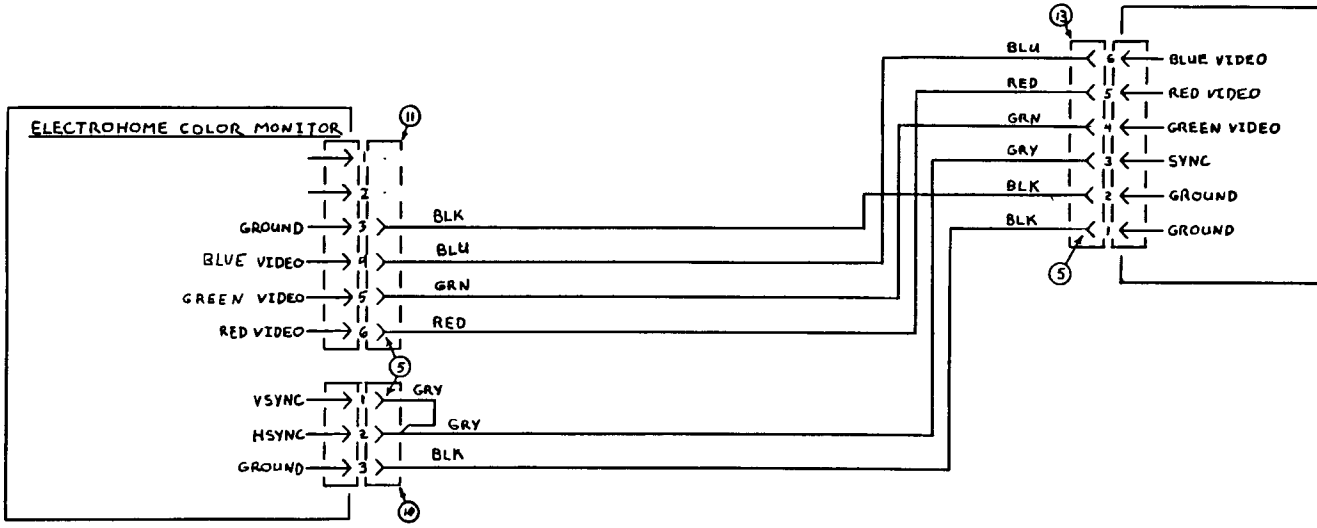
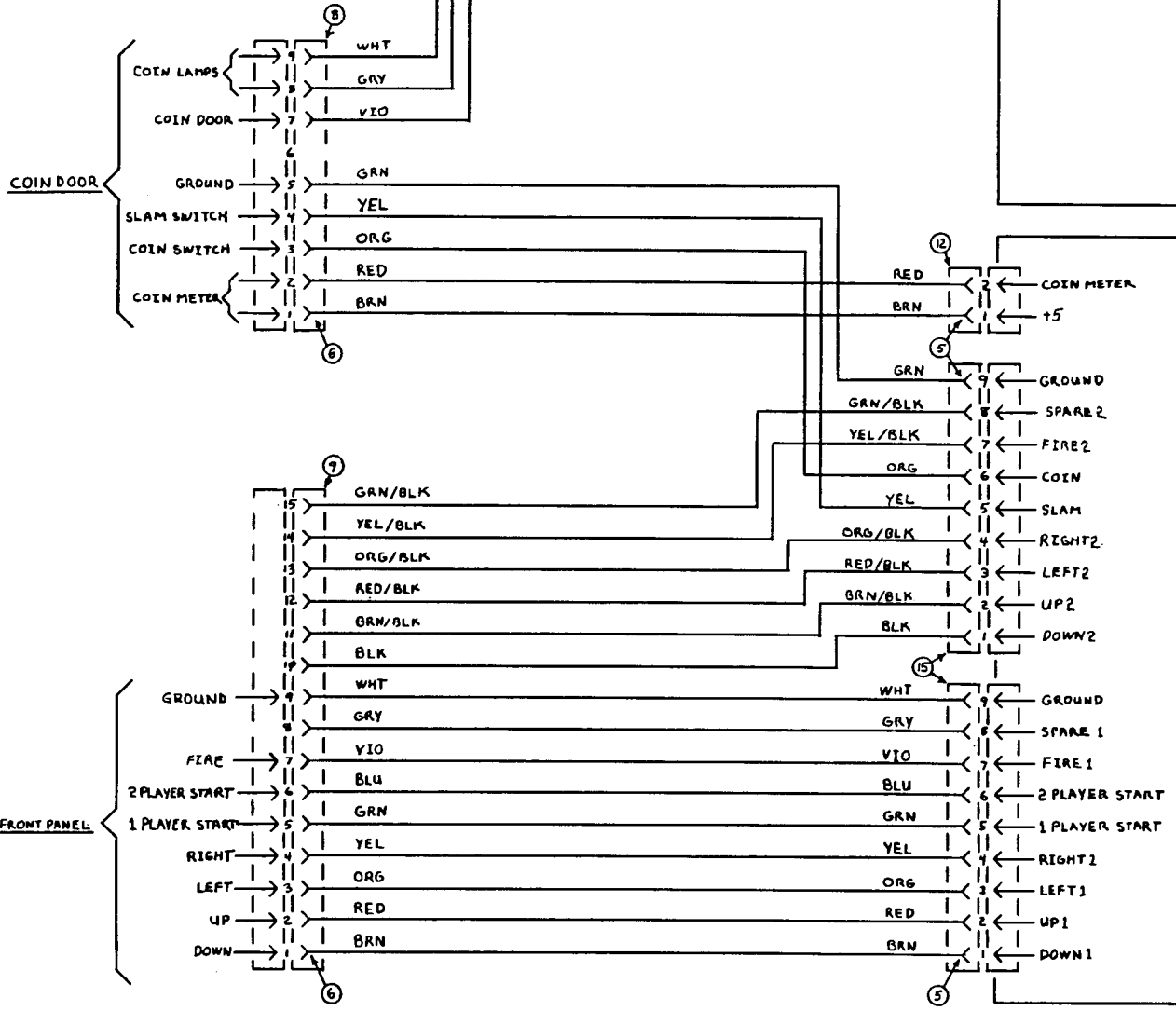

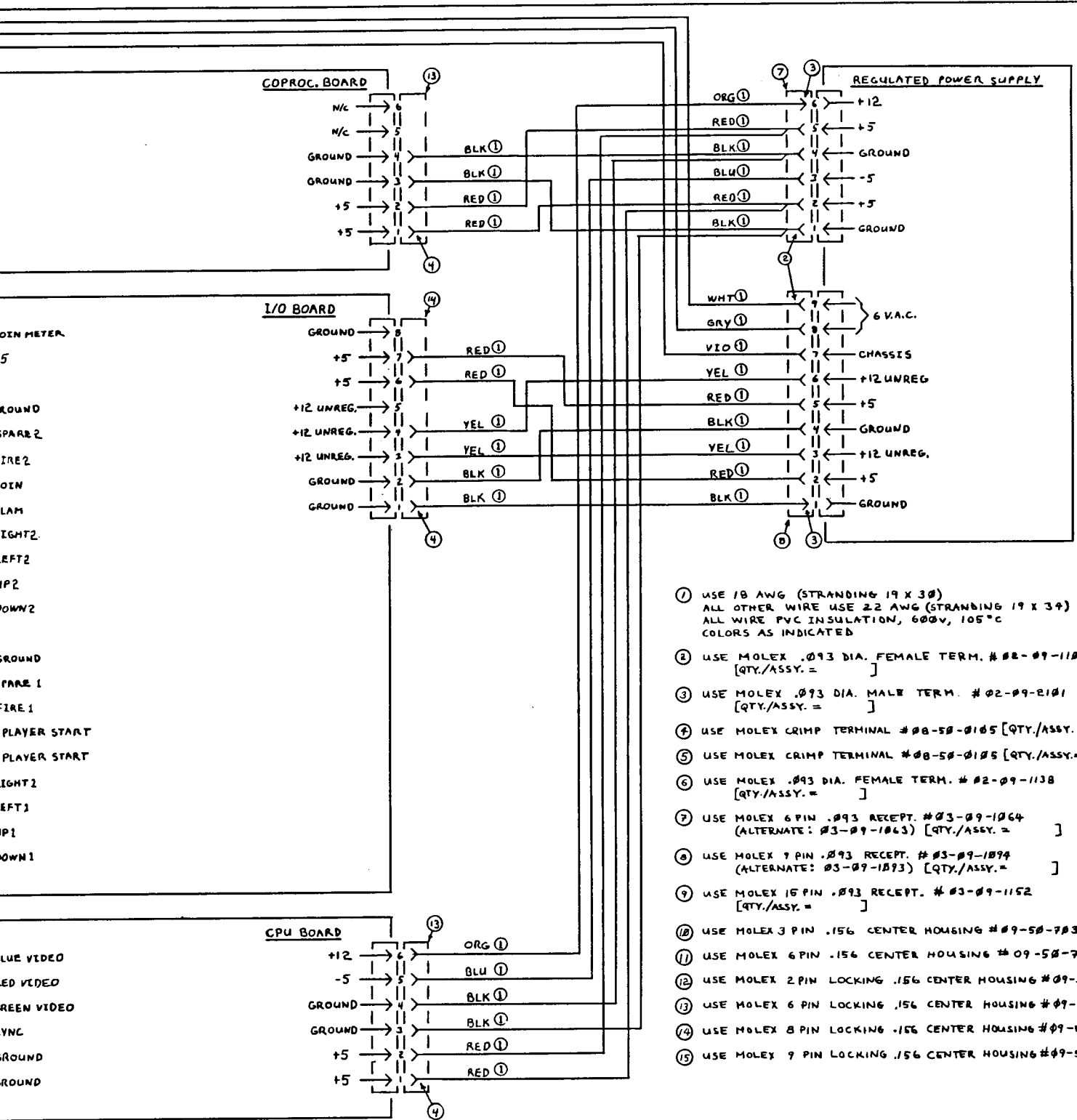

- ① USE 18 AWG (STRANDING 19 X 30) ALL OTHER WIRE USE 22 AWG (STRANDING 19 X 34) ALL WIRE PVC INSULATION, 600V, 105°C COLORS AS INDICATED
- ② USE MOLEX .093 DIA. FEMALE TERM. # 02-09-1102 [QTY./ASSY. = ]
- ③ USE MOLEX .093 DIA. MALE TERM. # 02-09-2101 [QTY./ASSY. = ]
- ④ USE MOLEX CRIMP TERMINAL # 08-50-0105 [QTY./ASSY. = ]
- ⑤ USE MOLEX CRIMP TERMINAL # 08-50-0106 [QTY./ASSY. = ]
- ⑥ USE MOLEX .093 DIA. FEMALE TERM. # 02-09-1138 [QTY./ASSY. = ]
- ⑦ USE MOLEX 6 PIN .093 RECEPT. # 03-09-1064 (ALTERNATE: 03-09-1063) [QTY./ASSY. = ]
- ⑧ USE MOLEX 7 PIN .093 RECEPT. # 03-09-1094 (ALTERNATE: 03-09-1093) [QTY./ASSY. = ]
- ⑨ USE MOLEX 15 PIN .093 RECEPT. # 03-09-1152 [QTY./ASSY. = ]
- ⑩ USE MOLEX 3 PIN .156 CENTER HOUSING # 09-50-7031
- ⑪ USE MOLEX 6 PIN .156 CENTER HOUSING # 09-50-7061
- ⑫ USE MOLEX 2 PIN LOCKING .156 CENTER HOUSING # 09-50-3021
- ⑬ USE MOLEX 6 PIN LOCKING .156 CENTER HOUSING # 09-50-3061
- ⑭ USE MOLEX 8 PIN LOCKING .156 CENTER HOUSING # 09-50-3081
- ⑮ USE MOLEX 9 PIN LOCKING .156 CENTER HOUSING # 09-50-3091

| REV | DRAWN   | BY | PACIFIC NOVELTY MANUFACTURING, INC.<br>MARINA DEL REY, CALIF            | ©1981        |
|-----|---------|----|-------------------------------------------------------------------------|--------------|
| A   | 11/8/81 | Ⓢ  |                                                                         |              |
| B   | 2/3/82  | FP |                                                                         |              |
| C   | 3/4/82  | FP | Assy., Harness, NATO MAIN<br>(FRONT PANEL, FRONT DOOR, DC POWER, VIDEO) |              |
| D   | 5/17/82 | Ⓢ  | 05-10000-01                                                             |              |
| E   | 6/22/82 | Ⓢ  |                                                                         | SHEET 1 OF 2 |

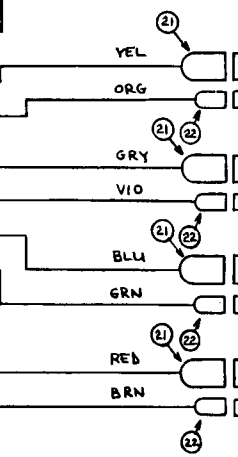
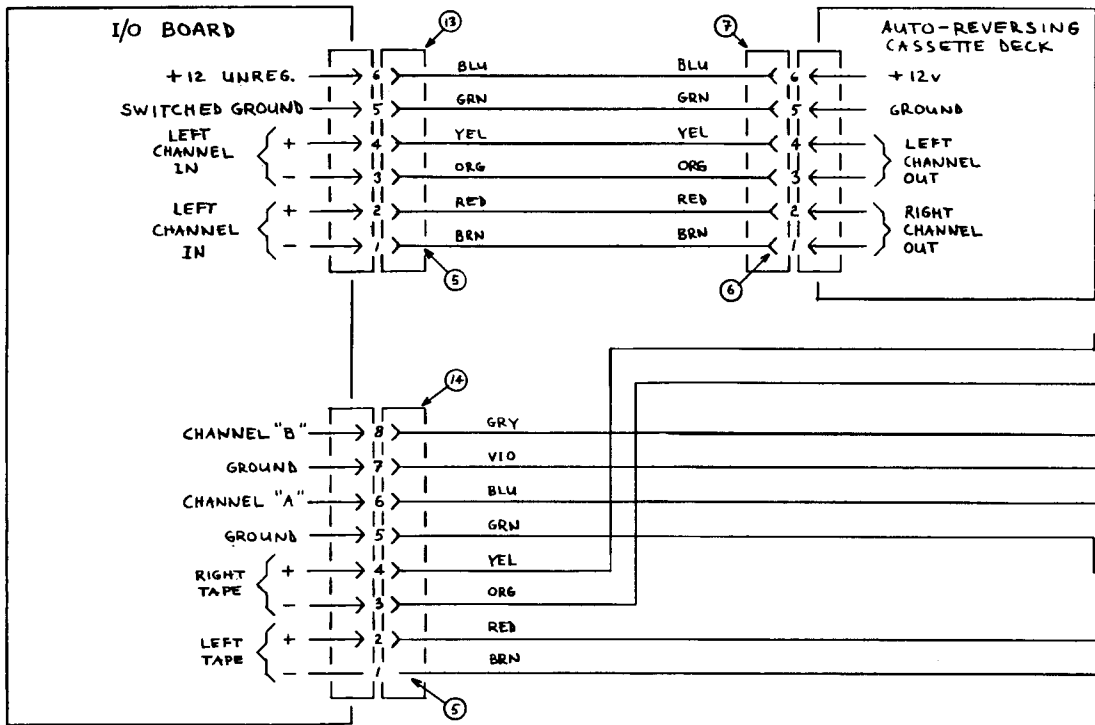
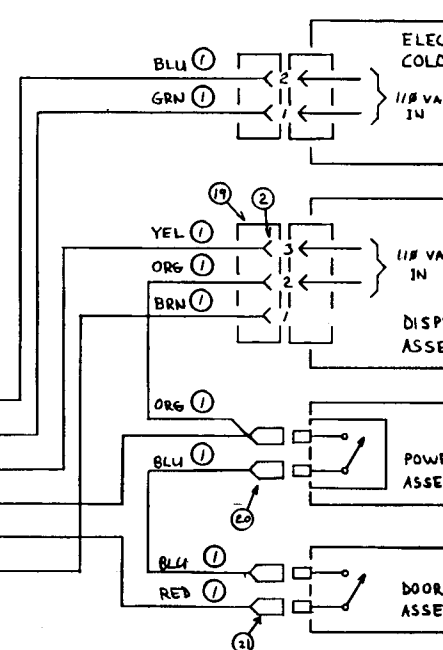
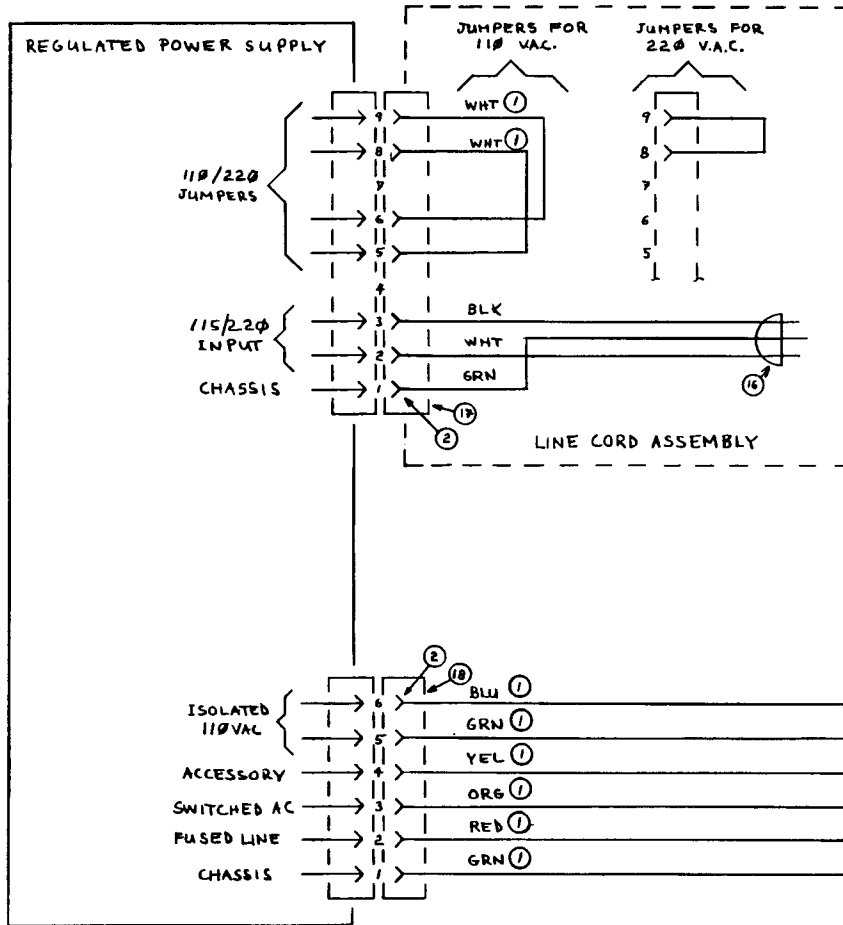



- ⑬ THREE CONDUCTOR POWER SUPPLY CORD, 18 AWG (STRANDING 16 x 30), 8' LENGTH, BLACK SJT VINYL JACKET
- ⑭ USE MOLEX 9 PIN .093 INTERNATIONAL RECEPT. # 19-09-1099
- ⑮ USE MOLEX 6 PIN .093 INTERNATIONAL RECEPT. # 19-09-1069
- ⑯ USE MOLEX 3 PIN .093 RECEPT. # 03-09-1032 (ALTERNATE: 03-09-1033)
- ⑰ USE .250" BY .032" FASTON RECEPT., FULLY INSULATED
- ⑱ USE .205" BY .032" FASTON RECEPT., FULLY INSULATED
- ⑳ USE .110" BY .032" FASTON RECEPT., FULLY INSULATED
- ㉓

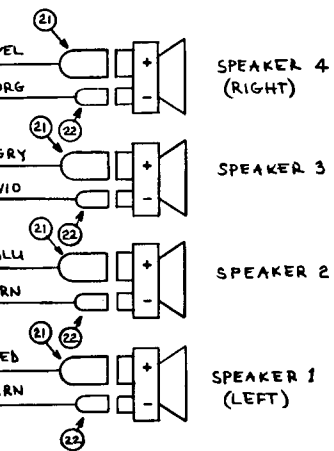
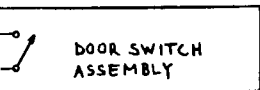
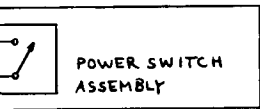
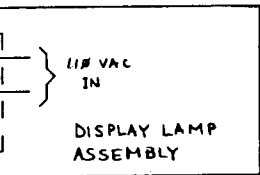
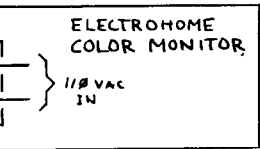

| REV. | DRAWN    | BY | PACIFIC NOVELTY MANUFACTURING, INC.<br>MARINA DEL REY, CA |
|------|----------|----|-----------------------------------------------------------|
| A    | 11-11-81 | GD | © 1981                                                    |
| B    | 2/3/82   | JP | 05-10000-01                                               |
| C    | 3/4/82   | JP | Assy., Harness, UPRIGHT MAIN                              |
| D    | 5/17/82  | Ⓟ  | (AC. POWER, LINE CORD, SPEAKERS, TAPEDECK)                |
| E    | 6/23/82  | Ⓟ  |                                                           |

1. USE JUMPERS J1 & J2  
2. CHIP SELECT ARE P20

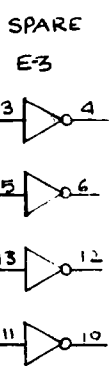
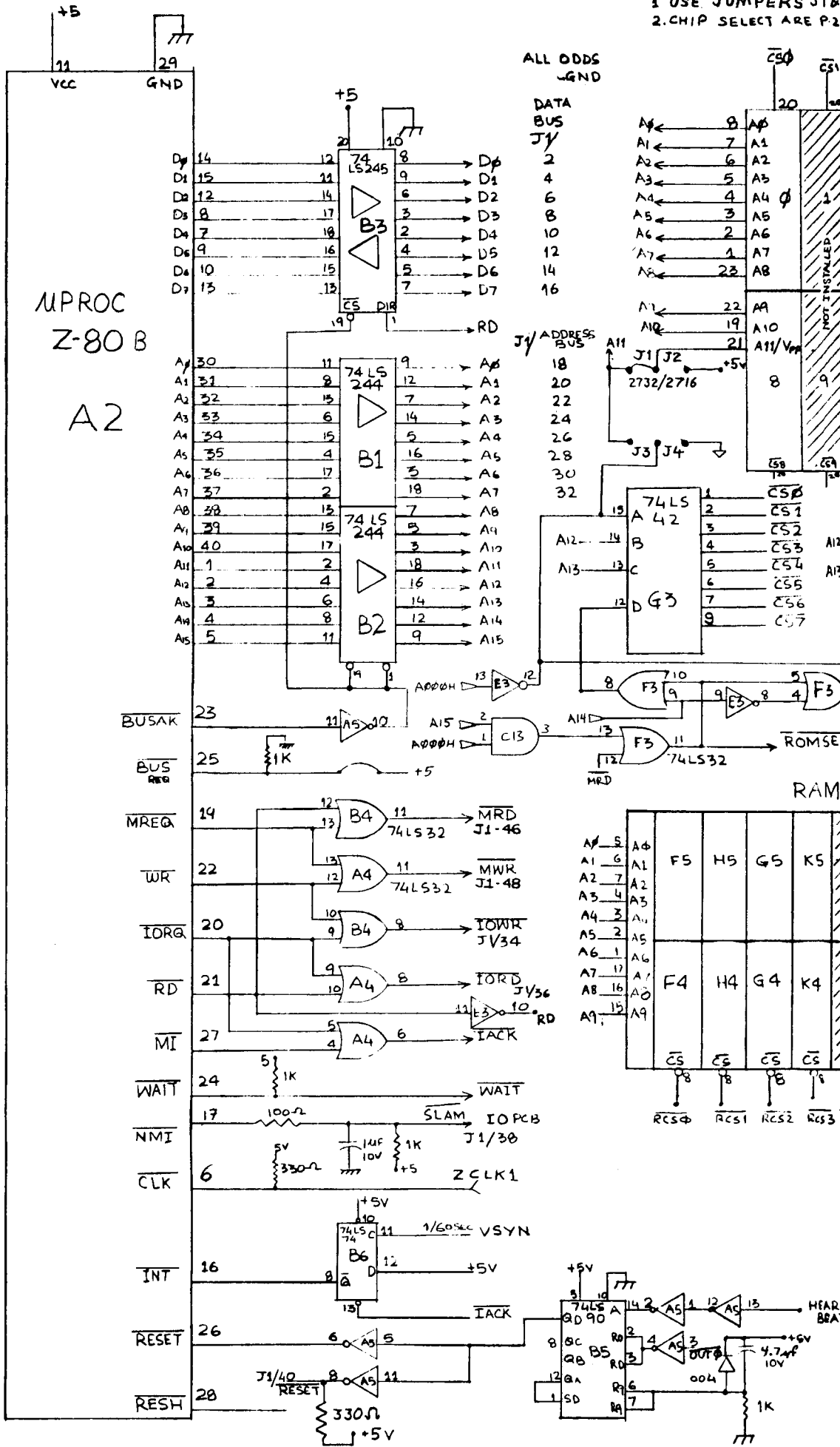

ALL ODDS -GND

DATA BUS JY

|    |   |    |
|----|---|----|
| 2  | 8 | D0 |
| 4  | 9 | D1 |
| 6  | 6 | D2 |
| 8  | 3 | D3 |
| 10 | 2 | D4 |
| 12 | 4 | D5 |
| 14 | 5 | D6 |
| 16 | 7 | D7 |

JY ADDRESS BUS

|    |    |     |
|----|----|-----|
| 18 | 9  | A0  |
| 20 | 12 | A1  |
| 22 | 7  | A2  |
| 24 | 14 | A3  |
| 26 | 5  | A4  |
| 28 | 16 | A5  |
| 30 | 3  | A6  |
| 32 | 18 | A7  |
|    | 7  | A8  |
|    | 5  | A9  |
|    | 3  | A10 |
|    | 18 | A11 |
|    | 16 | A12 |
|    | 14 | A13 |
|    | 12 | A14 |
|    | 9  | A15 |

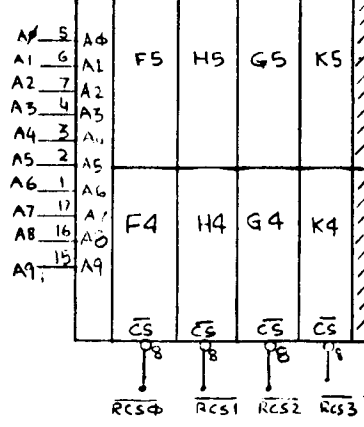
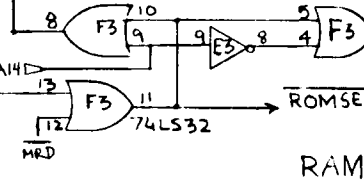
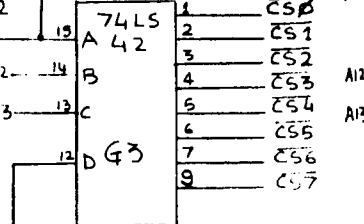

JUMPERS J1 & J4 FOR 2732 ROMS. USE J2 & J3 FOR 2716 ROM  
 SELECT ARE P20 AND TITLED CS# THRU CS15.

|     |                                          | REVISIONS |                    |
|-----|------------------------------------------|-----------|--------------------|
| LTR | DESCRIPTION                              | DATE      | APPROVED           |
| A   | PRODUCTION CHANGES                       | 01 30 82  | <i>[Signature]</i> |
| B   | REV 2A ECO # 2, 4, & 6                   | 02 07 82  |                    |
| C   | CHANGE TITLE, ADDRESS UP, ADD REV 3 ECO# | 4/22/82   |                    |

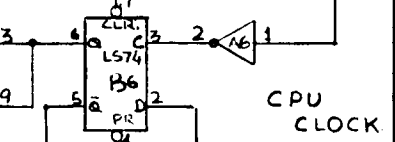
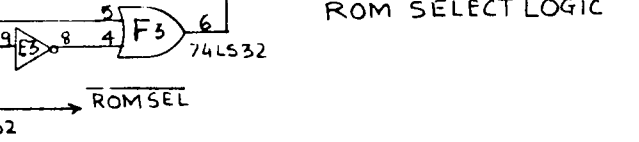
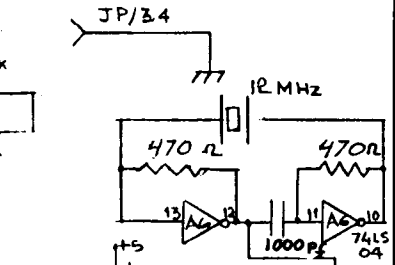
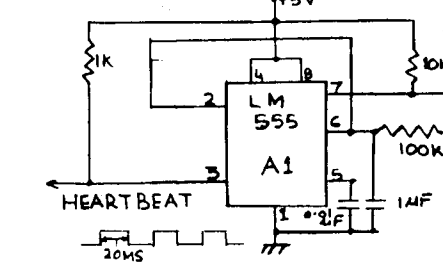
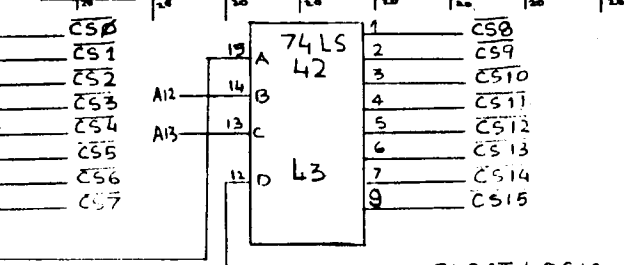
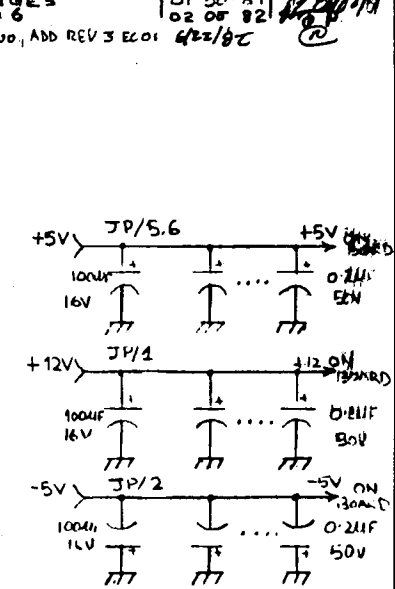
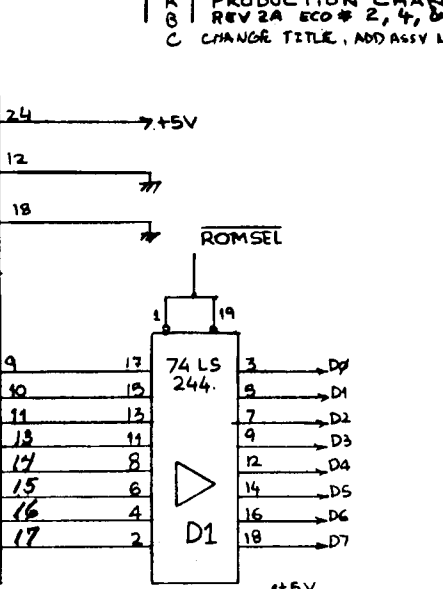
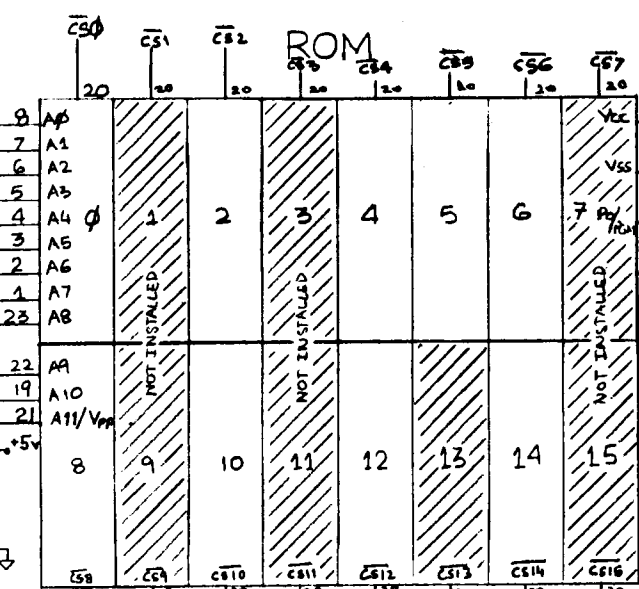

RAM 2114L3 TYP

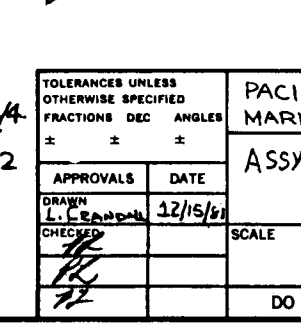
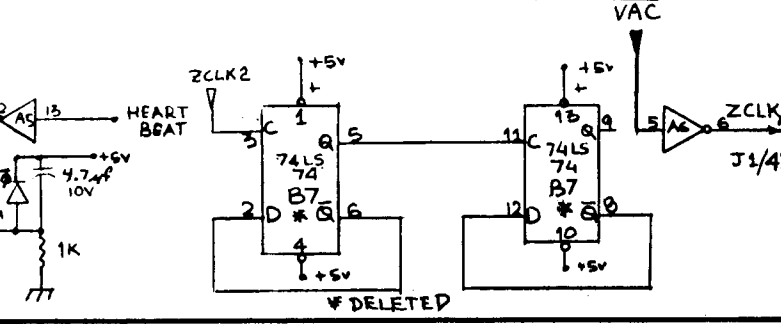
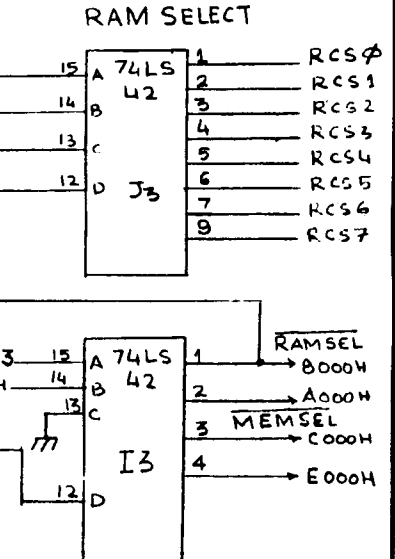
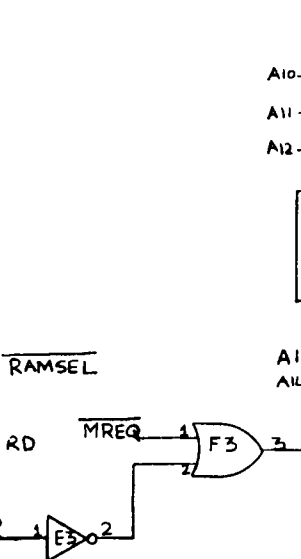
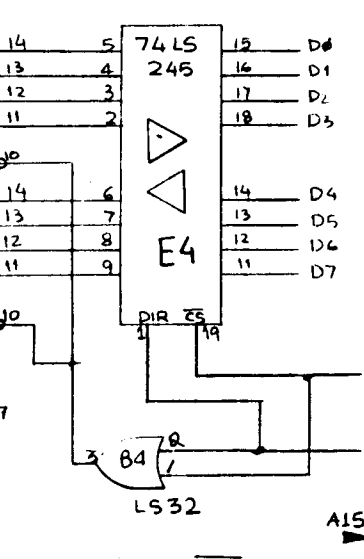
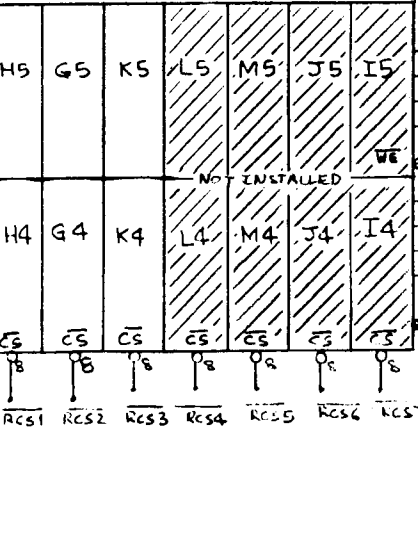

|                                       |          |                               |   |
|---------------------------------------|----------|-------------------------------|---|
| TOLERANCES UNLESS OTHERWISE SPECIFIED |          | FRACTIONS DEC ANGLES          |   |
| *                                     | *        | *                             | * |
| APPROVALS                             | DATE     | PACIFIC NOVELTY MANUFACTURING |   |
| DRAWN                                 | 12/15/81 | MARINA DEL REY CA-90291       |   |
| CHECKED                               |          | ASSY, PCB, NATO CPU REV 3     |   |
|                                       |          | 05-10035-01                   |   |
| SCALE                                 | SIZE     | DRAWING NO.                   |   |
|                                       | C        |                               |   |
| DO NOT SCALE DRAWING                  |          | SHEET 1 OF 4                  |   |



| REVISIONS |                                           | DATE      | APPROVED           |
|-----------|-------------------------------------------|-----------|--------------------|
| A         | PRODUCTION CHANGES.                       | 01 30 81. | <i>[Signature]</i> |
| B         | REV 2A ECO #'S 2, 4, & 6                  | 02 08 82  |                    |
| C         | CHANGE TITLE, ADD ASSY NO, ADD REV 3 ECOS | 11/22/82  |                    |

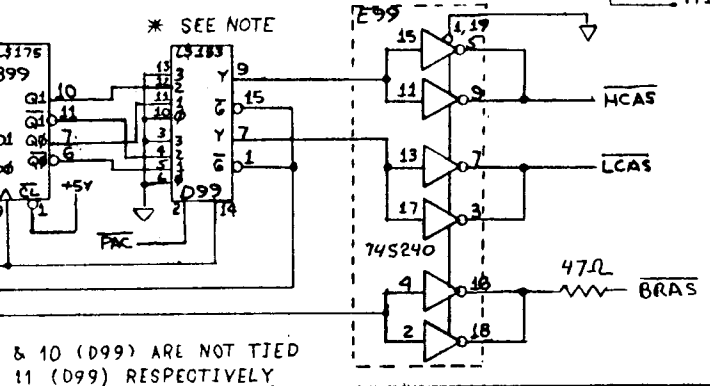
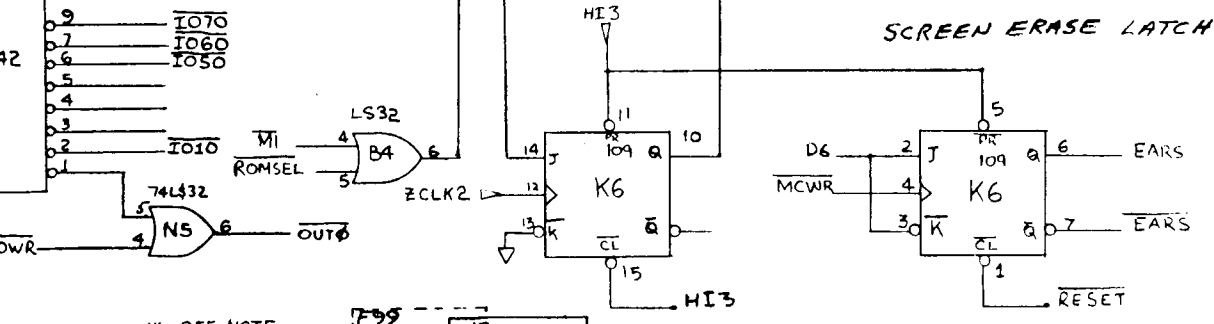
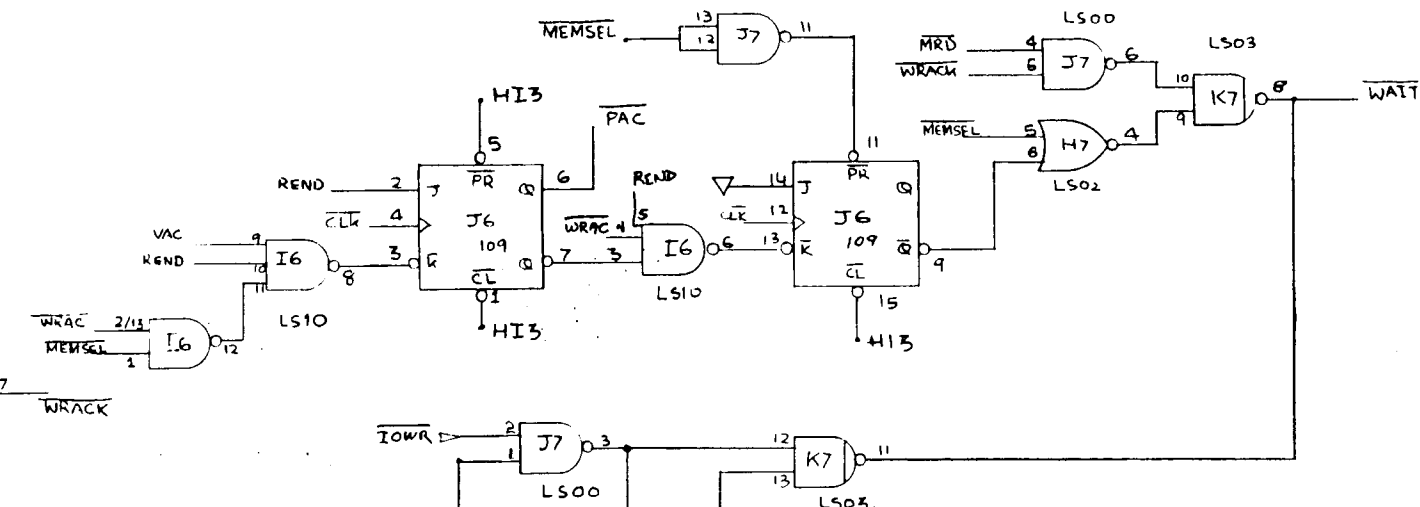
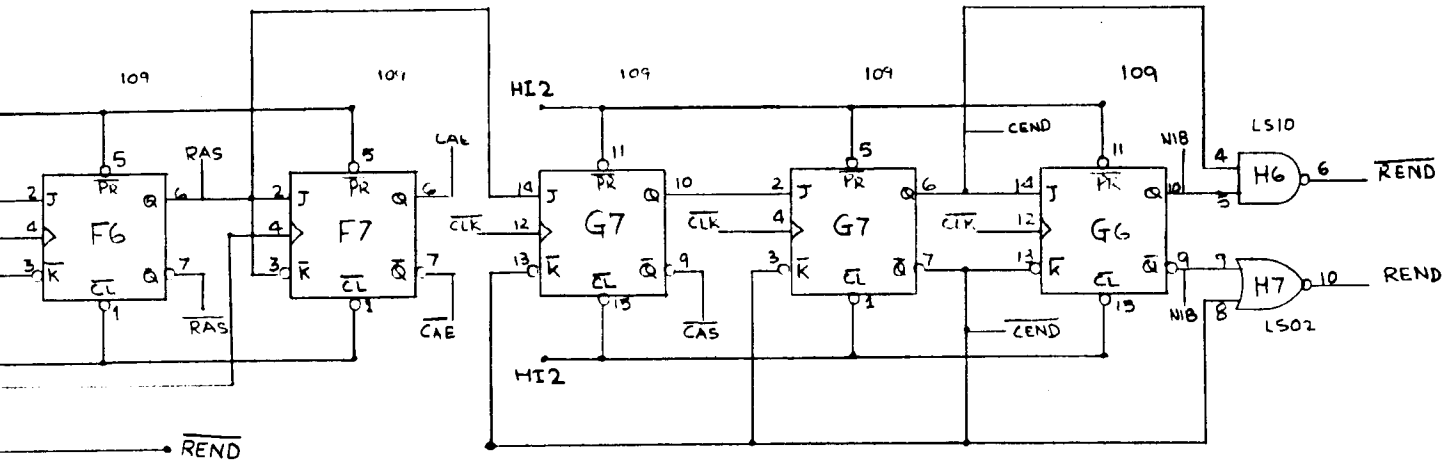
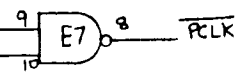

MI WAIT GENERATOR

|                                                                        |  |                                                          |           |
|------------------------------------------------------------------------|--|----------------------------------------------------------|-----------|
| TOLERANCES UNLESS OTHERWISE SPECIFIED<br>FRACTIONS DEC ANGLES<br>± ± ± |  | PACIFIC NOVELTY MANUFACTURING<br>MARINA DEL-REY CA-90291 |           |
| APPROVALS                                                              |  | DATE                                                     |           |
| DRAWN<br>L. COOPER                                                     |  | 12/15/81                                                 |           |
| CHECKED<br>[Signature]                                                 |  | SCALE                                                    | SIZE<br>C |
| DRAWING NO.                                                            |  | DRAWING NO.                                              |           |
| DO NOT SCALE DRAWING                                                   |  | SHEET 2 OF 4                                             |           |

& 10 (D99) ARE NOT TIED  
11 (D99) RESPECTIVELY

LS174

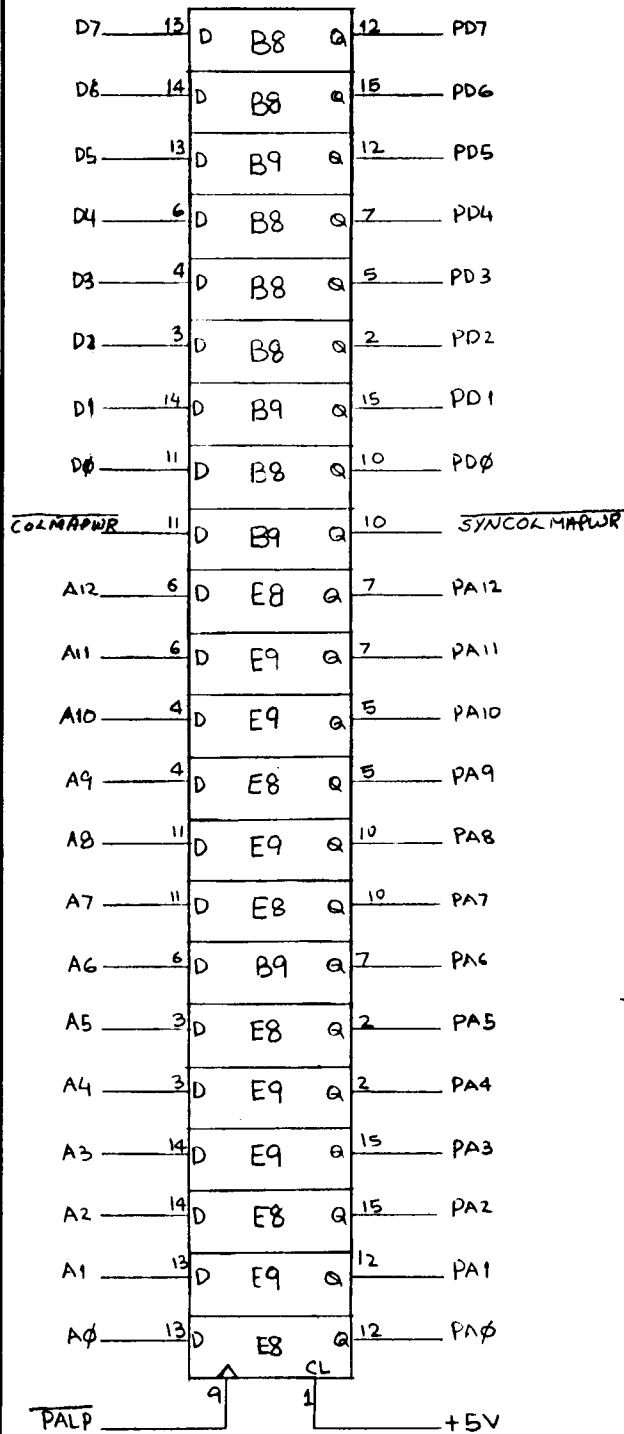

CPU: VIDEO PIPELINE REG

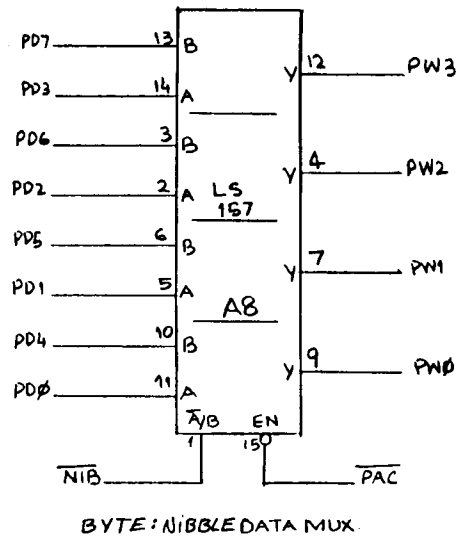

BYTE: NIBBLE DATA MUX

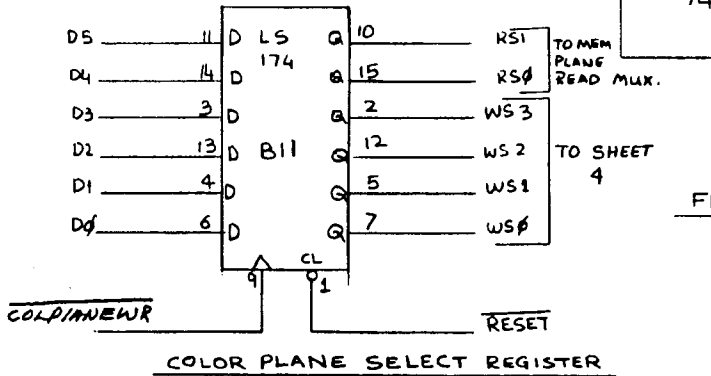
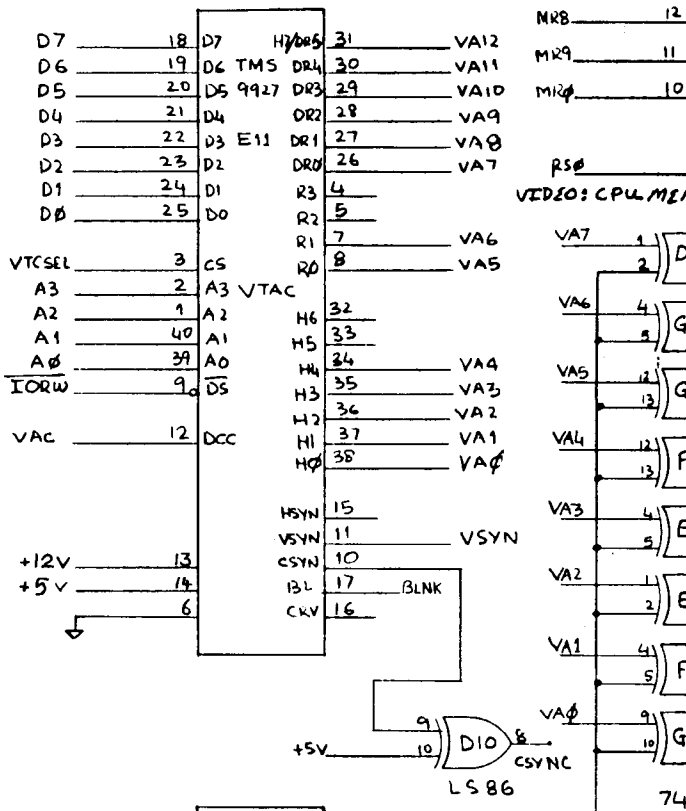

COLOR PLANE SELECT REGISTER



\* PIN 15 IS CONNECTED TO EITHER HCAS OR LCAS  
SEE RAM MATRIX TABLE FOR PHYSICAL LOCATION  
OF MEMORY CHIPS ON BOARD.

SYNCO MAPWR

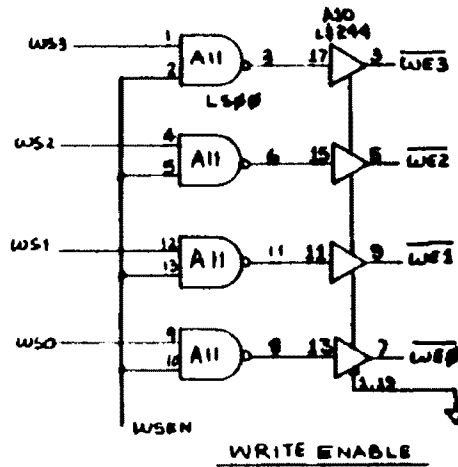
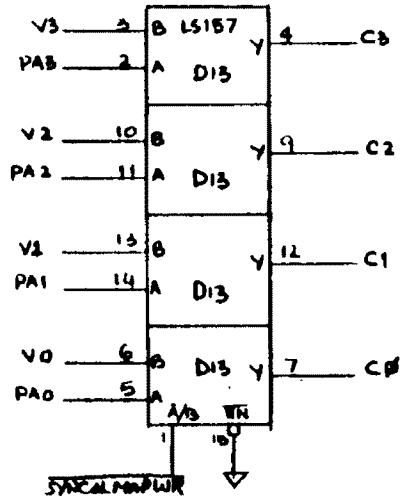
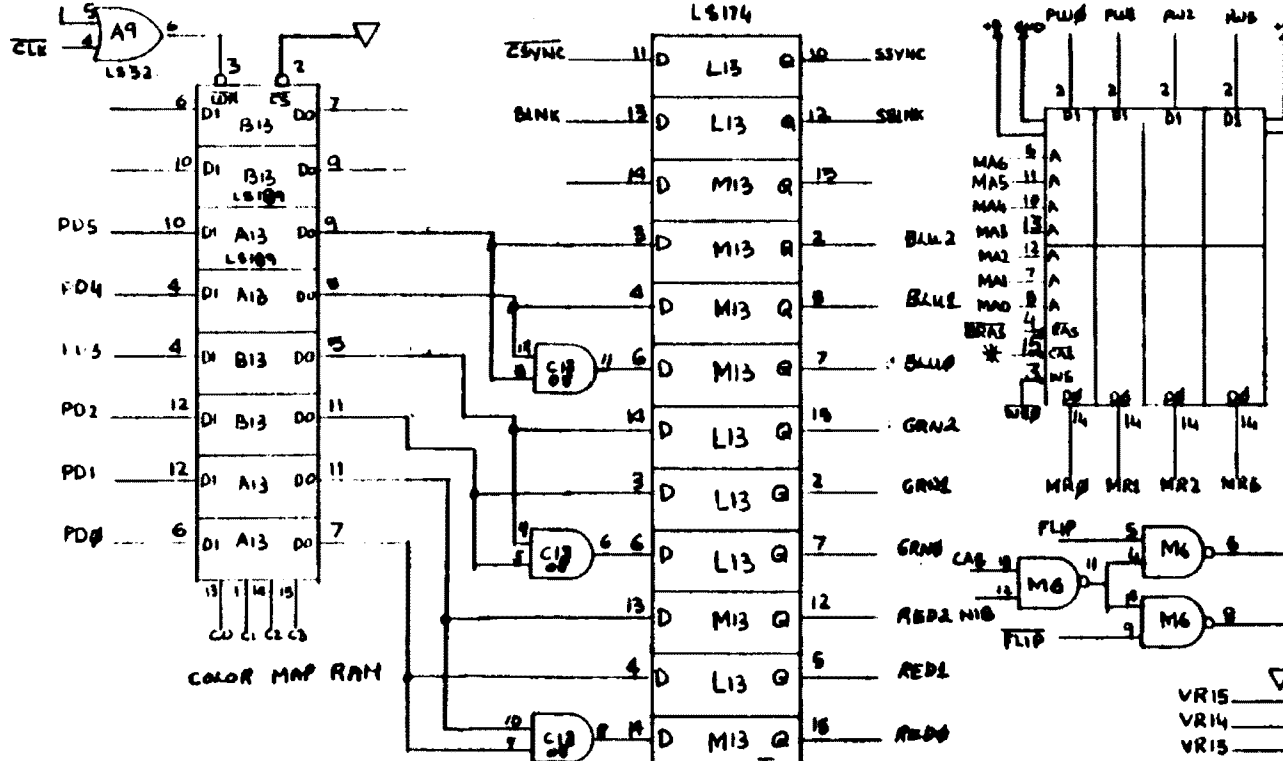

RAM MATRIX TABLE

| 9       | 8       | 7       | 6       | 5 | 4 | 3 | 2 | 1 |
|---------|---------|---------|---------|---|---|---|---|---|
| 8 HCAS  | 8 LCAS  | 8 LCAS  | 8 HCAS  |   |   |   |   |   |
| 9 HCAS  | 9 LCAS  | 9 LCAS  | 9 HCAS  |   |   |   |   |   |
| 10 HCAS | 10 LCAS | 10 LCAS | 10 HCAS |   |   |   |   |   |
| 11 HCAS | 11 LCAS | 11 LCAS | 11 HCAS |   |   |   |   |   |
| 12 HCAS | 12 LCAS | 12 LCAS | 12 HCAS |   |   |   |   |   |
| 13 HCAS | 13 LCAS | 13 LCAS | 13 HCAS |   |   |   |   |   |
| 14 HCAS | 14 LCAS | 14 LCAS | 14 HCAS |   |   |   |   |   |
| 15 HCAS | 15 LCAS | 15 LCAS | 15 HCAS |   |   |   |   |   |

NUMBERS ARE MR (DATA BITS).  
TABLE IS SET UP FOR REFERENCE  
WITH CPU POWER CABLE TO REAR.

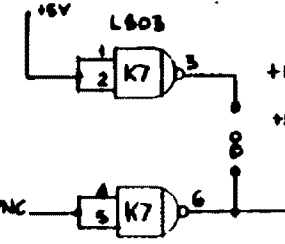



EITHER HCAS OR LCAS,  
PHYSICAL LOCATION  
D.

**VIDEO RAM**

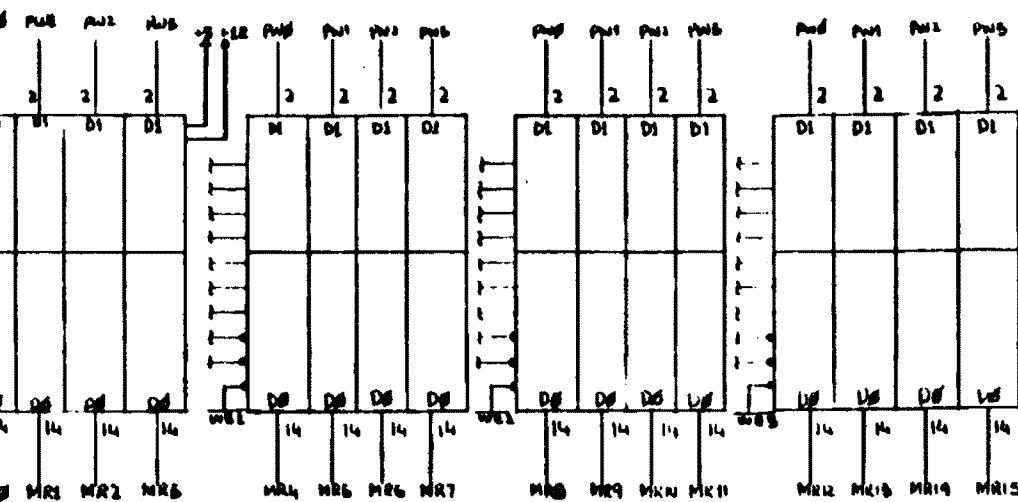

**BLUE, GREEN & RED OUTPUTS.**

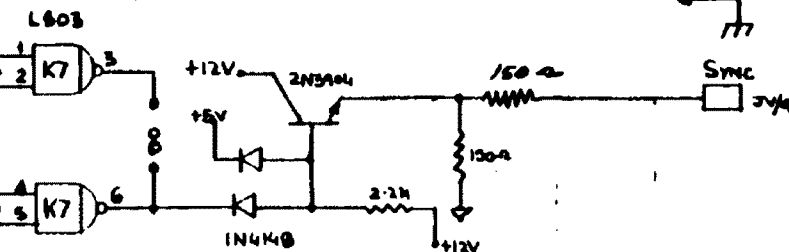
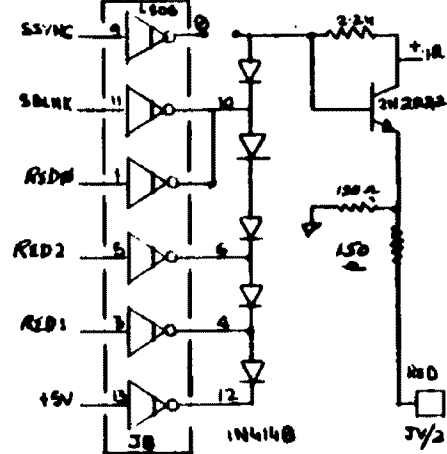
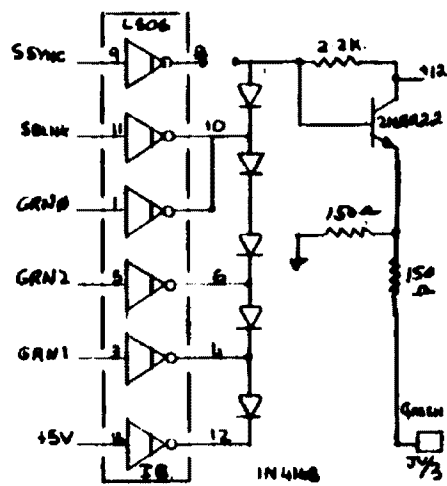
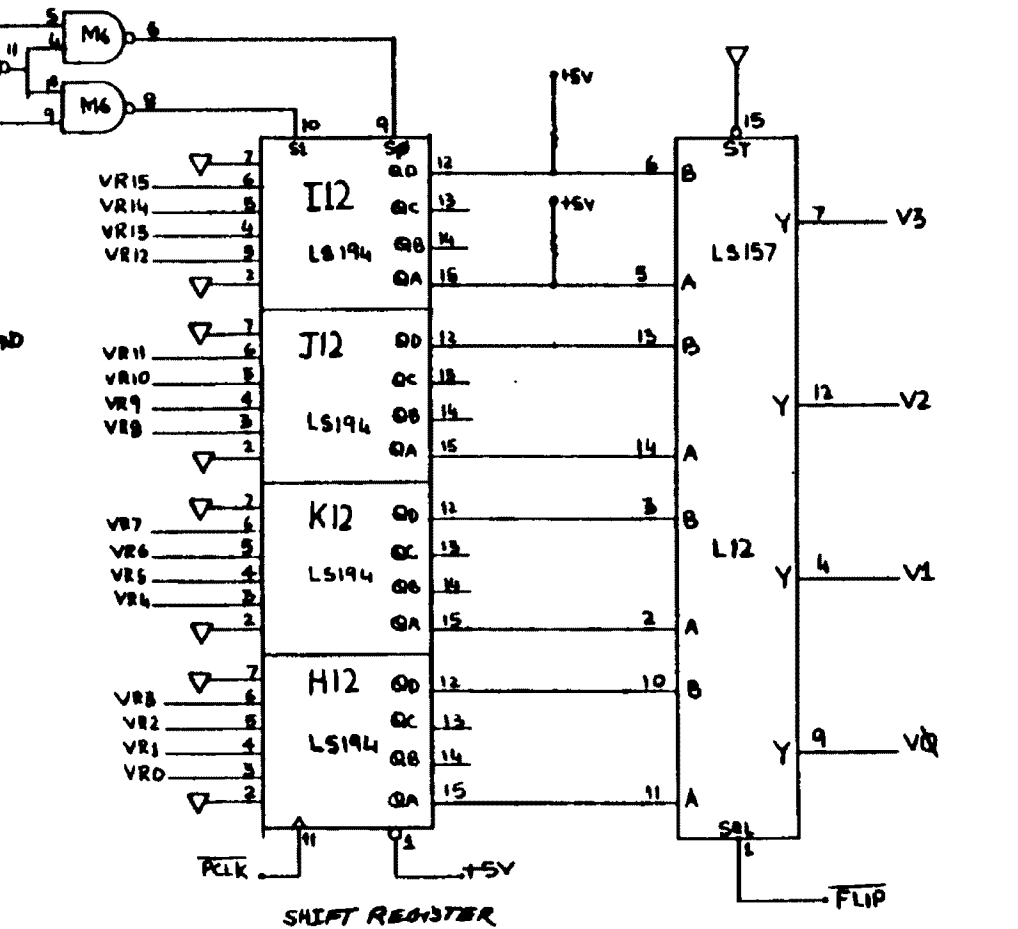
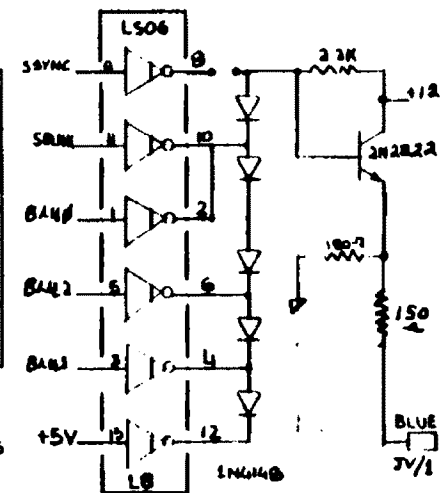

| TOLERANCES UNLESS OTHERWISE SPECIFIED |                  | FRACTIONS DEC ANGLES                                      |              |
|---------------------------------------|------------------|-----------------------------------------------------------|--------------|
| ±                                     | °                | °                                                         | °            |
| APPROVALS                             | DATE             | PACIFIC NOVELTY MANUFACTURING<br>MARINA DEL REY CA. 90292 |              |
| DRAWN BY<br>C. W. BALL                | DATE<br>12/16/81 | ASSY, P.C.B., NATO CPU REV 3<br>05-10035-01               |              |
| SCALE                                 | SIZE             | DRAWING NO.                                               |              |
|                                       | C                |                                                           |              |
| DO NOT SCALE DRAWING                  |                  |                                                           | SHEET 4 OF 4 |

