



TM-351  
2nd printing

# **Operator's Manual**



# **Race Drivin'**

TM



## **For technical assistance:**

If reading through this manual does not lead to solving your game maintenance or repair problem, call TELE-HELP® at one of these Atari Games Customer Service offices:

### **UNITED STATES**

Atari Games Corporation  
California Customer Service Office  
737 Sycamore Drive  
Milpitas, CA 95036-1110

**Fax (408) 434-3945**

**Telex 5101007850**

☎ **(408) 434-3950**

(Monday-Friday, 7:30 a.m.-4:00 p.m. Pacific time)

### **EUROPE**

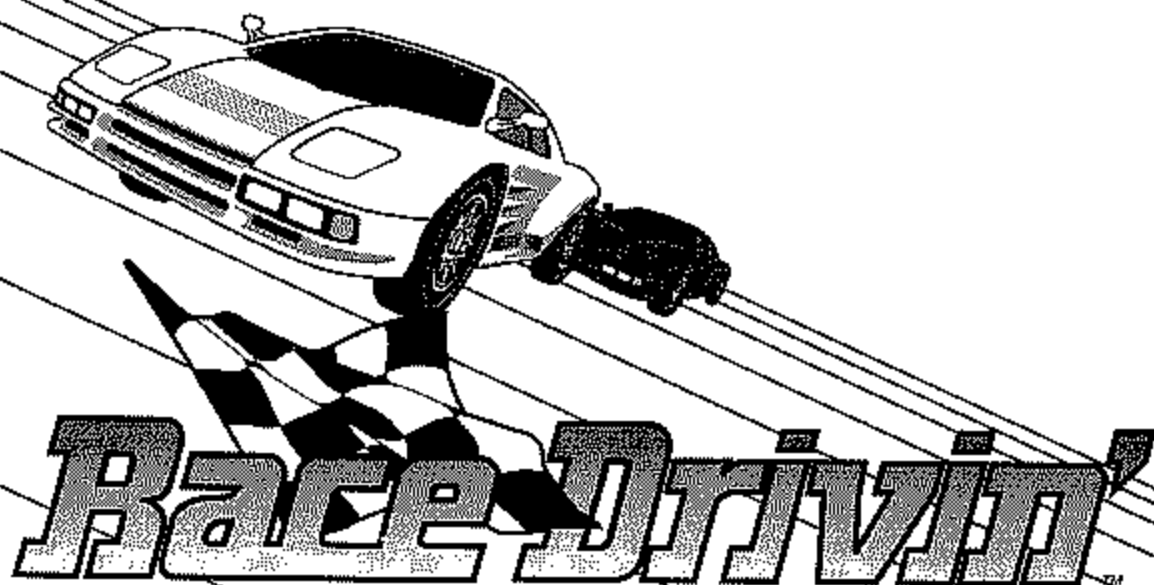
Atari Games Ireland Limited  
European Customer Service Office  
Tipperary Town, Ireland

**Fax 062-51702**

**Telex 70665**

☎ **062-52155**

(Monday-Friday, 9:00 a.m.-5:30 p.m. GMT)



## OPERATOR'S MANUAL

with Illustrated Parts Lists

*Patents are pending on several parts of the Race Drivin' simulator.*

**Copyright © 1988, 1989, 1990 by Atari  
Games Corporation. All rights  
reserved.**

No part of this publication may be reproduced by any mechanical, photographic or electronic process, or in the form of a phonographic recording, nor may it be stored in a retrieval system, transmitted, or otherwise copied for public or private use, without permission from the publisher.

The game play, all graphic designs, this technical manual, its accompanying schematic diagrams, and the display manual are protected by the U.S. Copyright Act of 1976.

This Act provides for substantial penalties for violating federal copyright laws. Courts can impound infringing articles while legal action is pending. If infringers are convicted, courts can order destruction of the infringing articles.

In addition, the Act provides for payment of statutory damages of up to \$50,000 per infringing transaction in certain cases. Infringers may also have to pay costs and attorneys' fees and face an imprisonment of up to five years as well as fines of up to \$250,000 in the case of individuals and up to \$500,000 in the case of corporations.

Atari Games Corporation will aggressively enforce its copyrights against infringers. We will use all legal means to immediately halt any manufacture, distribution, or operation of a copy of video games made by us. Anyone who purchases such copies risks forfeiting such a game.

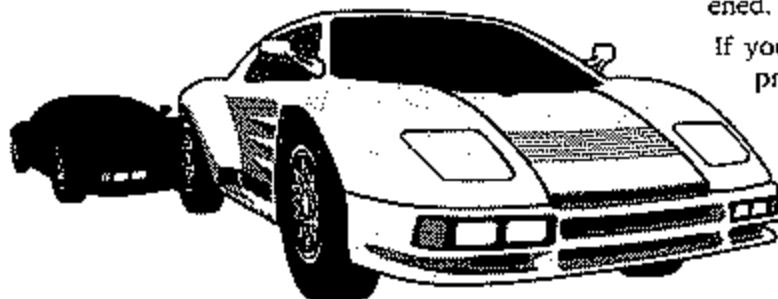
Published by:  
Atari Games Corporation  
675 Sycamore Drive  
P.O. Box 361110  
Milpitas, California 95036

Printed in the U.S.A. 11/90

Produced by the Atari Games Technical Publications Department.

Writing & Editing: Andrea Dencker

Illustration & Design: Mary Ohanessian Sumner



## Notice Regarding Non-Atari® Parts

### WARNING

*Use of non-Atari parts or modifications of any Atari game circuitry may adversely affect the safety of your game, and may cause injury to you and your players.*

You may void the game warranty (printed on the inside back cover of this manual) if you do any of the following:

- Substitute non-Atari parts in the game.
- Modify or alter any circuits in the game by using kits or parts *not* supplied by Atari Games Corporation.

### NOTE

This equipment generates, uses, and can radiate radio frequency energy, and if not installed and used in accordance with the instruction manual, may cause interference to radio communications. It has been tested and found to comply with the limits for a Class A computing device pursuant to Subpart J of Part 15 of Federal Communications Commission (FCC) Rules, which are designed to provide reasonable protection against such interference when operated in a commercial environment. Operation of this equipment in a residential area or modification to this equipment is likely to cause interference, in which case the user, at his own expense, will be required to take whatever measures may be required to correct the interference. If you suspect interference from an Atari game at your location, check the following:

- All ground wires in the game are properly connected as shown in the game wiring diagram.
- The power cord is properly plugged into a grounded three-wire outlet.
- On games provided with an Electromagnetic Interference (EMI) ground cage, be sure that the game printed-circuit boards (PCBs) are properly installed on the EMI ground cage and that the end board is securely installed with **all** screws in place and tightened.

If you are still unable to solve the interference problem, please contact Customer Service at Atari Games Corporation. See the inside front cover of this manual for service in your area.

# Table of Contents

## 1 Set Up

|   |     |
|---|-----|
| How to Use This Manual .....                  | 1-1 |
| Operating the Simulator .....                 | 1-2 |
| Inspecting the Simulator .....                | 1-2 |
| Installing the Attraction Sign Assembly ..... | 1-2 |
| Adjusting the Glides .....                    | 1-3 |
| Control and Switch Locations .....            | 1-3 |
| Setting the Coin and Game Options .....       | 1-3 |
| Simulator Systems .....                       | 1-3 |
| Maximizing Earnings .....                     | 1-4 |
| Simulator Driving .....                       | 1-4 |

## 2 Self-Test

|   |      |
|---|------|
| <b>Entering and Exiting the Self-Test</b> ..... | 2-2  |
| <b>Automated Self-Test</b> .....                | 2-2  |
| Program ROM and RAM Test .....                  | 2-3  |
| Microprocessor and Board Tests .....            | 2-3  |
| <b>Test Menu Screens</b> .....                  | 2-4  |
| <b>Operator Screens</b> .....                   | 2-4  |
| Coin Options .....                              | 2-4  |
| Game Difficulty .....                           | 2-5  |
| Game Options .....                              | 2-8  |
| Statistics .....                                | 2-8  |
| Histogram .....                                 | 2-10 |
| Error Count .....                               | 2-10 |
| Games Played by Day and Hour .....              | 2-10 |
| <b>Set Controls Screens</b> .....               | 2-10 |
| <b>Control Inputs Screen</b> .....              | 2-11 |
| <b>Monitor Test Patterns</b> .....              | 2-12 |
| <b>Set Clock Screen</b> .....                   | 2-12 |
| <b>Disable Broken Controls Screen</b> .....     | 2-13 |
| <b>Special Functions Screen</b> .....           | 2-13 |
| Main Board GSP Tests .....                      | 2-14 |
| Main Board Controls .....                       | 2-15 |
| Steering Wheel Submenu .....                    | 2-15 |
| Shifter Test Screen .....                       | 2-16 |
| Link Connector Test .....                       | 2-17 |
| Main Board ROM Checksums .....                  | 2-17 |
| Main Board ZRAM Test .....                      | 2-17 |
| ADSP Board Tests .....                          | 2-17 |
| Sound Board .....                               | 2-18 |
| <b>DSK Board Tests</b> .....                    | 2-19 |
| <b>LEDs on the Main PCB</b> .....               | 2-20 |
| <b>DIP Switches</b> .....                       | 2-20 |

## 3 Maintenance and Troubleshooting

|  |      |
|--|------|
| <b>Maintaining and Inspecting</b> .....                                | 3-2  |
| Maintaining Your Simulator .....                                       | 3-2  |
| <b>Dashboard</b> .....   | 3-2  |
| Removing the Dashboard .....   | 3-2  |
| Installing the Dashboard .....   | 3-3  |
| <b>Steering Assembly</b> .....   | 3-4  |
| Greasing the Steering Assembly .....                                   | 3-5  |
| Replacing the Steering Assembly Potentiometer .....                    | 3-5  |
| Replacing the Steering Wheel Motor .....                               | 3-9  |
| Replacing the Steering Wheel Stop .....                                | 3-10 |
| <b>Key Switch Assembly</b> .....                                       | 3-11 |
| Oiling the Key Switch Assembly .....                                   | 3-11 |
| Replacing the Spring in the Key Switch Assembly .....                  | 3-11 |
| Tightening the Screw in the Key Switch Actuator .....                  | 3-11 |
| Replacing the Switch on the Key Switch Assembly .....                  | 3-12 |
| <b>Clutch Pedal</b> .....  | 3-13 |
| Maintaining the Clutch and Brake Pedals .....                          | 3-13 |
| Replacing the Clutch Potentiometer .....                               | 3-13 |
| Replacing the Clutch Springs .....                                     | 3-15 |
| <b>Brake Pedal</b> .....   | 3-17 |
| Repairing the Brake .....  | 3-17 |
| Testing the Switch, Switch Actuator Distance, and Pedal Movement ..... | 3-17 |
| Testing the Strain Gauge and the Strain Gauge Bonding .....            | 3-17 |
| Replacing the Brake Switch .....                                       | 3-18 |
| Replacing the Brake Strain Gauge and Pedal Assembly .....              | 3-19 |
| <b>Gas Pedal Assembly</b> .....  | 3-19 |
| Lubricating the Gas Pedal .....  | 3-19 |
| Rewinding the Gas Pedal Pulley Cable .....                             | 3-20 |
| Replacing the Gas Pedal Cable Spring .....                             | 3-21 |
| Replacing the Gas Pedal Potentiometer .....                            | 3-21 |
| Replacing a Broken Spring on the Gas Pedal .....                       | 3-23 |
| <b>Shifter Assembly</b> .....  | 3-24 |
| Installing a New Shifter Boot .....                                    | 3-24 |
| Removing the Reverse Latch Pin .....                                   | 3-24 |
| Replacing a Shifter Potentiometer .....                                | 3-24 |
| Replacing the Shifter Solenoid .....                                   | 3-27 |
| <b>Seat Assembly</b> .....   | 3-27 |
| Replacing the Seat Rod End Bearings .....                              | 3-27 |
| Replacing Bearings on the Seat Pivot .....                             | 3-28 |
| Replacing Main Seat Bearings .....                                     | 3-31 |
| Replacing the Gears on the Seat Assembly .....                         | 3-32 |
| Replacing the Small Gear .....   | 3-32 |
| Replacing the Large Gear .....   | 3-34 |
| Replacing the Magnet on the Seat Assembly .....                        | 3-34 |
| Replacing the Seat Potentiometer .....                                 | 3-34 |
| <b>Video Display</b> .....   | 3-35 |
| Removing the Video Display .....                                       | 3-35 |
| Replacing the Video Display .....                                      | 3-36 |

|   |      |
|---|------|
| <b>Motor Amplifier Assembly</b> .....           | 3-37 |
| Removing the Motor Amplifier Assembly.....      | 3-37 |
| <b>Speakers</b> .....                           | 3-37 |
| Removing a Speaker.....                         | 3-37 |
| <b>PC Board Stack</b> .....                     | 3-38 |
| Removing a Board from the PC Board Stack.....   | 3-38 |
| <b>Replacing Static-Sensitive Devices</b> ..... | 3-38 |
| <b>Cleaning the Coin Mechanism</b> .....        | 3-39 |
| <b>Cleaning the Interior Components</b> .....   | 3-39 |

## 4 Illustrated Parts Lists

See the List of Illustrations that follows.

### Statistics Sheet

## List of Illustrations

|             |  |      |
|-------------|--|------|
| Figure 1-1  | Attraction Sign Installation.....  | 1-3  |
| Figure 2-1  | Program ROM and RAM Test Screen..  | 2-3  |
| Figure 2-2  | Microprocessor and Board Tests Screen..  | 2-3  |
| Figure 2-3  | Instructions for Test Menu Screen.....   | 2-4  |
| Figure 2-4  | Test Menu Screen .....   | 2-4  |
| Figure 2-5  | Coin Options Screen .....  | 2-4  |
| Figure 2-6  | Game Difficulty Screen .....   | 2-5  |
| Figure 2-7  | Custom Game Options Screen.....  | 2-5  |
| Figure 2-8  | Game Options Screen .....  | 2-8  |
| Figure 2-9  | Statistics Screen.....   | 2-9  |
| Figure 2-10 | Histogram Screen.....  | 2-10 |
| Figure 2-11 | Games Played by Day and Hour Screen  | 2-11 |
| Figure 2-12 | First Set Controls Screen.....   | 2-11 |
| Figure 2-13 | Control Inputs Screen.....   | 2-11 |
| Figure 2-14 | Set Clock Screen.....  | 2-12 |
| Figure 2-15 | Disable Broken Controls Screen.....  | 2-13 |
| Figure 2-16 | Special Functions Screen.....  | 2-14 |
| Figure 2-17 | GSP Tests Screen .....   | 2-14 |
| Figure 2-18 | Main Board Controls Screen .....   | 2-15 |
| Figure 2-19 | Pots: 8-Bit Screen.....  | 2-15 |
| Figure 2-20 | Pots: 12-Bit Screen.....   | 2-16 |
| Figure 2-21 | Steering Wheel Submenu Screen.....   | 2-16 |
| Figure 2-22 | Send Force Screen .....  | 2-16 |
| Figure 2-23 | Shifter Screen .....   | 2-17 |
| Figure 2-24 | Link Connector Test Screen .....   | 2-17 |
| Figure 2-25 | ROM Checksums Screen .....   | 2-18 |
| Figure 2-26 | ADSP Board Tests Screen.....   | 2-18 |
| Figure 2-27 | ADSP ROM Checksums Tests Screen  | 2-19 |
| Figure 2-28 | Sound Board Tests Screen.....  | 2-19 |
| Figure 2-29 | Sound Board Sound Wave ROM<br>Checksums Screen.....  | 2-19 |
| Figure 2-30 | DSK Board Test Screen .....  | 2-20 |
| Figure 2-31 | DIP Switch and LED Locations on<br>the Main PCB .....  | 2-21 |
| Figure 3-1  | Removing and Installing the<br>Dashboard.....  | 3-4  |
| Figure 3-2  | Steering Wheel Has No Feedback<br>and You Have Tried the <i>Set<br/>Controls</i> Screens .....                                     | 3-6  |
| Figure 3-3  | Steering Wheel is Turned All the Way<br>to One Side and You Have Tried the<br><i>Set Controls</i> Screens.....                     | 3-7  |
| Figure 3-4  | Steering Wheel is Jerky and You Have<br>Tried the <i>Set Controls</i> Screens .....  | 3-8  |
| Figure 3-5  | Maintaining the Steering Wheel.....  | 3-10 |
| Figure 3-6  | Maintaining the Key Switch<br>Assembly .....   | 3-12 |
| Figure 3-7  | Clutch, Seat, or Gas Pedal is Not<br>Working or Working Erratically and<br>You Have Tried the <i>Set Controls</i><br>Screens ..... | 3-14 |
| Figure 3-8  | Maintaining the Clutch and Brake<br>Assembly .....   | 3-16 |
| Figure 3-9  | Brake is Not Working or Working<br>Erratically and You Have Tried<br>the <i>Set Controls</i> Screens .....                         | 3-18 |
| Figure 3-10 | Rewinding the Gas Pedal Pulley<br>Cable .....  | 3-20 |
| Figure 3-11 | Maintaining the Gas Pedal .....  | 3-22 |
| Figure 3-12 | Shifter is Not Working or Working<br>Erratically and You Have Already<br>Tried the <i>Set Controls</i> Screens.....                | 3-25 |
| Figure 3-13 | Maintaining the Shifter .....  | 3-26 |
| Figure 3-14 | Seat is Not Locked When it Should<br>Be and You Have Already Tried<br>the <i>Set Controls</i> Screens .....                        | 3-29 |
| Figure 3-15 | Seat is Locked When it Should<br>Not Be and You Have Already<br>Tried the <i>Set Controls</i> Screens .....                        | 3-30 |
| Figure 3-16 | Maintaining the Seat Assembly .....  | 3-33 |
| Figure 3-17 | Removing the Video Display .....   | 3-37 |
| Figure 3-18 | Disassembling the PC Board Stack...  | 3-39 |
| Figure 4-1  | Cabinet-Mounted Assemblies.....  | 4-2  |
| Figure 4-2  | Seat Assembly .....  | 4-8  |
| Figure 4-3  | Dashboard Assembly.....  | 4-10 |
| Figure 4-4  | Key Switch Assembly .....  | 4-12 |



|             |   |      |
|-------------|---|------|
| Figure 4-5  | Steering Assembly.....                          | 4-14 |
| Figure 4-6  | Shifter Assembly .....                          | 4-16 |
| Figure 4-7  | Clutch and Brake Pedal Assembly....             | 4-18 |
| Figure 4-8  | Gas Pedal Assembly .....                        | 4-20 |
| Figure 4-9  | Coin Acceptors, Inc. Coin Door<br>Assembly..... | 4-22 |
| Figure 4-10 | Power Supply Assembly.....                      | 4-26 |
| Figure 4-11 | Hard Drivin' Main PCB Assembly.....             | 4-30 |
| Figure 4-12 | APU PCB Assembly .....                          | 4-36 |
| Figure 4-13 | Shifter PCB Assembly .....                      | 4-38 |
| Figure 4-14 | Brake PCB Assembly .....                        | 4-40 |

## List of Tables

|           |   |      |
|-----------|---|------|
| Table 1-1 | Simulator Specifications.....                       | 1-2  |
| Table 2-1 | Using the Self-Test Screens and<br>Diagnostics..... | 2-2  |
| Table 2-2 | Coin Option Settings .....                          | 2-5  |
| Table 2-3 | All Screens Appearing in the<br>Self-Test .....     | 2-6  |
| Table 2-4 | Game Option Settings .....                          | 2-8  |
| Table 2-5 | When to Use the Special Function<br>Items .....     | 2-14 |
| Table 2-6 | LED Status .....                                    | 2-20 |
| Table 2-7 | Using the DIP Switches.....                         | 2-22 |

|           |   |      |
|-----------|---|------|
| Table 3-1 | Maintenance and Inspection Items.....                         | 3-2  |
| Table 3-2 | Troubleshooting All Controls .....                            | 3-3  |
| Table 3-3 | Voltage Inputs and Test Points on<br>the Simulator PCBs ..... | 3-3  |
| Table 3-4 | Troubleshooting the Steering<br>Assembly .....                | 3-5  |
| Table 3-5 | Troubleshooting the Key Switch.....                           | 3-11 |
| Table 3-6 | Troubleshooting the Clutch Pedal .....                        | 3-13 |
| Table 3-7 | Troubleshooting the Brake Pedal .....                         | 3-17 |



|            |   |      |
|------------|---|------|
| Table 3-8  | Troubleshooting the Gas Pedal<br>Assembly ..... | 3-21 |
| Table 3-9  | Troubleshooting the Shifter<br>Assembly .....   | 3-24 |
| Table 3-10 | Troubleshooting the Seat Assembly...            | 3-28 |
| Table 3-11 | Troubleshooting the Video Display ...           | 3-36 |
| Table 3-12 | Troubleshooting the Speakers.....               | 3-38 |

# Safety Summary

The following safety precautions apply to all game operators and service personnel. Specific warnings and cautions will be found in this manual whenever they apply.

## WARNING

**Properly Ground the Game.** Players may receive an electrical shock if this game is not properly grounded! To avoid electrical shock, do not plug in the game until it has been inspected and properly grounded. This game should only be plugged into a grounded three-wire outlet. If you have only a two-wire outlet, we recommend you hire a licensed electrician to install a three-wire grounded outlet. If the control panel is not properly grounded, players may receive an electrical shock! After servicing any part on the control panel, check that the grounding wire is firmly secured to the inside of the control panel. After you have checked this, lock up the game.

**AC Power Connection.** Before you plug in the game, be sure that the game's power supply can accept the AC line voltage in your location. The line voltage requirements are listed in the first chapter of this manual.

**Disconnect Power During Repairs.** To avoid electrical shock, disconnect the game from the AC power before removing or repairing any part of the game. If you remove or repair the video display, be very careful to avoid electrical shock. High voltages continue to exist even after power is disconnected in the display circuitry and the cathode-ray tube (CRT). Do not touch the internal parts of the display with your hands or with metal objects! Always discharge the high voltage from the CRT before servicing it. Do this after you disconnect it from the power source. First, attach one end of a large, well-insulated, 18-gauge jumper wire to ground. Then momentarily touch the free end of the grounded jumper wire to the CRT anode by sliding the wire under the anode cap. Wait two minutes and do this again.

**Use Only Atari Parts.** To maintain the safety of your Atari game, use only Atari parts when you repair it. Using non-Atari parts or modifying the game circuitry may be dangerous, and could injure you and your players.

**Handle the CRT With Care.** If you drop the CRT and it breaks, it may implode! Shattered glass from the implosion can fly six feet or more.

**Use the Proper Fuses.** To avoid electrical shock, use replacement fuses which are specified in the parts list for this game. Replacement fuses must match those replaced in fuse type, voltage rating, and current rating. In addition, the fuse cover must be in place during game operation.

## CAUTION

**Properly Attach All Connectors.** Make sure that the connectors on each printed circuit board (PCB) are properly plugged in. The connectors are keyed to fit only one way. If they do not slip on easily, do not force them. If you reverse a connector, it may damage your game and void your warranty.

**Ensure the Proper AC Line Frequency.** Video games manufactured for operation on 60 Hz line power (used in the United States) must not be operated in countries with 50 Hz line power (used in Europe). If a 60 Hz machine operates on 50 Hz line power, the fluorescent line ballast transformer will overheat and cause a potential fire hazard. Check the product identification label on your machine for the line frequency required.

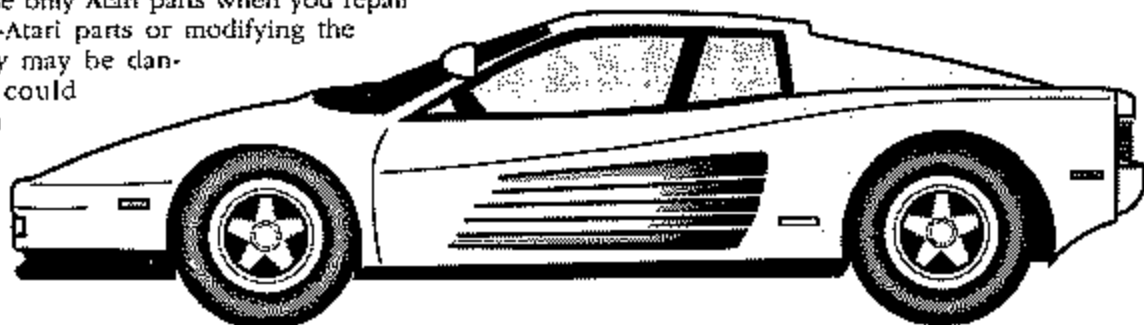
## ABOUT NOTES, CAUTIONS, AND WARNINGS

In Atari publications, notes, cautions and warnings have the following meaning:

**NOTE** — A highlighted piece of information.

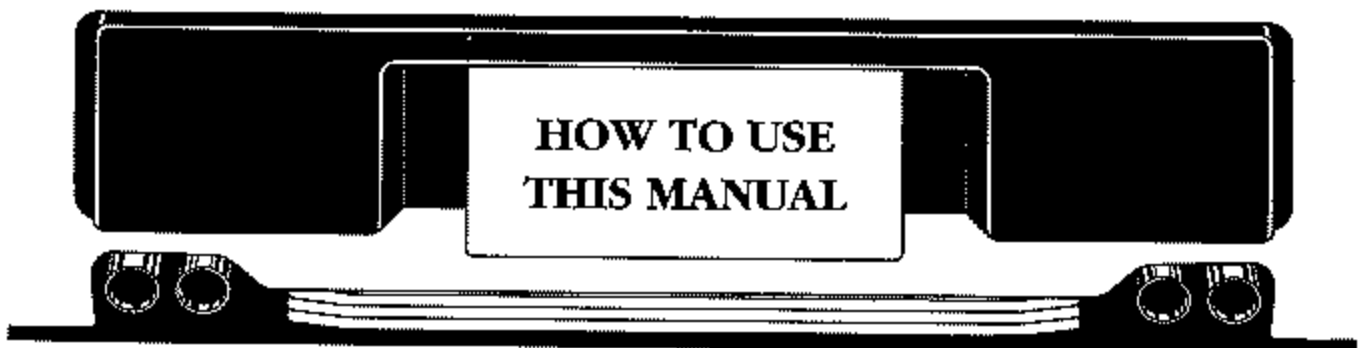
**CAUTION** — Equipment and/or parts can be damaged or destroyed if instructions are not followed. You will void the warranty on Atari printed-circuit boards, parts thereon, and video displays if equipment or parts are damaged or destroyed due to failure of following instructions.

**WARNING** — Players and/or technicians can be killed or injured if instructions are not followed.





# Set-Up



This manual is written for operators and service personnel. It provides information for setting up, driving, testing, and maintaining your Race Drivin™ simulator. ■ Chapter 1 contains set-up and simulator driving information. ■ Chapter 2 contains self-test procedures and additional diagnostic tests. The self-test is important in the Race Drivin' simulator. You can troubleshoot the PC boards, main circuits, and controls using the more than 60 screens in the self-test. You should regularly test the boards and controls with

the self-test to keep your simulator in peak condition and at top earnings. ■ Chapter 3 contains the preventive maintenance schedule for the simulator and the repair procedures, flowcharts, and troubleshooting tables for each control. If you have problems with your simulator, use this chapter to troubleshoot and to repair it. Be sure to perform the preventive maintenance tasks to keep your simulator in good condition. ■ Chapter 4 contains the illustrated parts lists. ☺ ☺ ☺  
☺ ☺ ☺ ☺ ☺ ☺ ☺ ☺ ☺ ☺ ☺ ☺ ☺

## Operating the Simulator

To operate your simulator for maximum income, make sure your players know that the simulator is designed to be driven like a real car. You should regularly do the automated self-test and check the controls with the *Control Inputs* screen in the self-test. By using the self-test regularly, you can find and fix problems immediately. This lets you keep your simulator in top condition.

### NOTE

*If you are installing a new printed-circuit (PC) board or a control in your simulator, go through the Set Controls screen in the self-test. This is explained in Chapter 2.*

*If you turn on your simulator and you see a screen that says Initialize Pot Inputs instead of the attraction screens, then reset the controls by following the instructions on the screens that appear.*

## Inspecting the Simulator

### WARNING

*To avoid electrical shock, do not plug in the cabinet until it has been properly inspected and set up for the line voltage in your area.*

This cabinet should be connected to a grounded three-wire outlet only. If you have only two-wire outlets, we recommend that you hire a licensed electrician to install grounded outlets. Players can receive an electrical shock if the cabinet is not properly grounded.

Inspect your Race Drivin' simulator carefully to ensure that the simulator is complete and was delivered to you in good condition.

Inspect the cabinet and seat as follows:

1. Examine the exterior of the cabinet for dents, chips, or broken parts.
2. Open the lower service door and the small top service panel. (Leave this top panel open so you can install the attraction sign.) Unlock and open the coin doors. Inspect the interior of the cabinet as follows:
  - a. Check that all plug-in connectors on the cabinet harnesses are firmly plugged in. Do not force connectors together. The connectors are keyed so they fit only in the proper orientation. A reversed connector can damage a printed-circuit board (PCB). This will void your warranty.

**Table 1-1 Simulator Specifications**

| Characteristic         | Specification               |
|------------------------|-----------------------------|
| Power Consumption      | 635 W maximum               |
| Line Fuse Rating       | 7 Amps                      |
| Line Voltage           | 102 to 132 VAC              |
| Temperature            | 5° to 38° C (37° to 100° F) |
| Humidity               | Not to exceed 95% relative  |
| Width                  | 31 1/2 in. (81 cm.)         |
| Depth (seat pushed in) | 62 1/2 in. (160 cm.)        |
| Height                 | 77 in. (197 cm.)            |
| Weight                 | 750 lbs. (341 kg.)          |

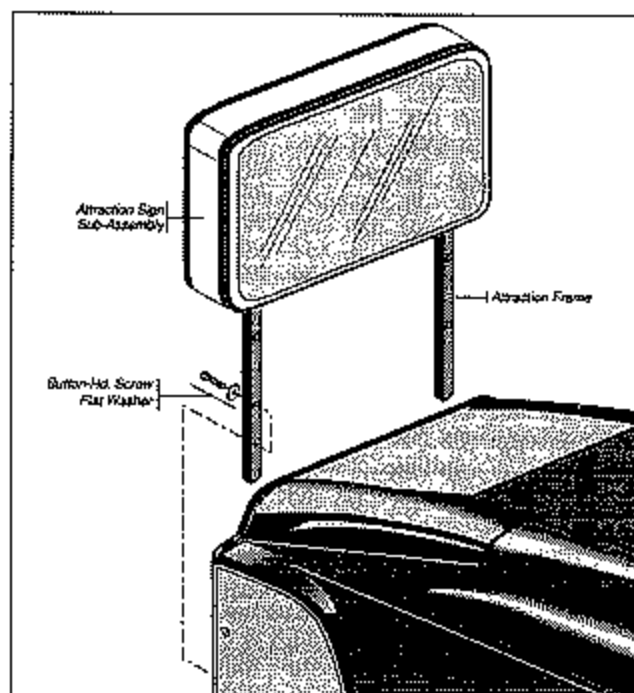
- b. Ensure that all plug-in integrated circuits on each PCB are firmly plugged into their sockets.
- c. Inspect the power cord for any cuts or dents in the insulation.
- d. Inspect the power supply. Make sure that the correct fuses are installed. Check that the harness is plugged in correctly and that the fuse block cover is mounted in place. Check that the green ground wires are connected.
- e. Inspect other sub-assemblies, such as the video display, controls, printed-circuit boards (PCBs), and speakers. Make sure that they are mounted securely and that the ground wires are connected.

## Installing the Attraction Sign Assembly

The attraction sign assembly is shipped uninstalled with the simulator. Mount the sign on the back of the cabinet as shown in Figure 1-1.

The hardware for assembling the sign and for mounting it is shipped in the cash box. This hardware consists of ten 1/4-20 button-head screws 2 inches long with black washers.

1. Lay the attraction sign face down on a clean surface where it will not be scratched.
2. Lay the H-shaped attraction frame on top of the sign. Put the short ends of the H on top of the sign. The harness connection in the leg should face the sign. Attach the harness from the sign to the harness in the leg. Push the extra wires inside the leg of the attraction frame.
3. Install six screws and washers through the attraction frame and into the attraction sign. Tighten the screws.



**Figure 1-1 Attraction Sign Installation**

Now install the attraction sign assembly on the back of the simulator. You need the other four screws and flat washers.

4. Open the small top rear panel of the simulator if you have not done so already.
5. Connect the simulator harness to the harness in the left leg of the sign. Now push the extra wires back inside the simulator. Be careful that the harness does not lie on the motor amplifier assembly, mounted on the side of the cabinet.
6. Put the attraction sign against the cabinet, and line up the four holes in the legs with the four holes in the cabinet.
7. Put the button-head screws and black washers into the legs, and screw them into the threaded holes.

## Adjusting the Glides

After you move the simulator into location, screw out the adjustable glides in the base to support it. The Race Drivin' simulator is heavy, and if you do not put down the glides, the casters may be damaged.

Before you move the simulator, retract the glides so they are not damaged.

## Control and Switch Locations

### Power On/Off Switch

The power on/off switch is located at the bottom rear of the cabinet.

### Volume Control

The volume control is located behind the upper coin door.

### Self-Test Switch

The self-test switch is located behind the upper coin door. See Chapter 2 for a complete description of the self-test.

### Auxiliary Coin Switches

An auxiliary coin switch is located on the component bracket behind the upper coin door. Use the auxiliary coin switch to give players coin credits.

### Coin Counter

The coin counter is located behind the upper coin door. The coin counter records the number of coins deposited. It does not count the credits given by the auxiliary coin switch.

## Setting the Coin and Game Options

The Race Drivin' coin and game options are set in the self-test. Refer to Chapter 2 for the recommended settings and the procedure for setting the options.

## Simulator Systems

The Race Drivin' simulator uses eight PCBs to give a realistic look and feel to the driving. These PCBs are the main PCB, the ADSP PCB, the motor amplifier PCB (with two motor amplifier driver PCBs), the shifter PCB, the brake PCB, the audio and power PCB (mounted on the power supply assembly), the sound PCB, and the DSK PCB. These PCBs control simulator software, the video display, and the controls.

The main PCB, which is the largest, holds the 68010, the GSP, and the microprocessor systems. The 68010 system contains program RAM and ROM. The GSP (Graphic Systems Processor) microprocessor system controls the video RAMs (VRAMs).

The ADSP board, the sound board, and the DSK board are mounted with the main PCB. The motor amplifier PCB is mounted in a heatsink assembly located on the driver's left. It controls the steering wheel motor. The shifter PCB is located on the driver's right and controls the gear shifter effects. The brake PCB is located on

the brake and clutch pedal assembly and controls the braking effects.

## Maximizing Earnings

For maximum earnings, regularly maintain your Race Drivin' simulator following the instructions in Table 3-1, in Chapter 3.

When you set up the simulator and when you collect money, perform the automated self-test and check the controls with the *Control Inputs* screen in the self-test.

## Simulator Driving

This section describes the features and driving of the Race Drivin' simulator.

### Introduction

Race Drivin' includes all of the innovative game features that made *Hard Drivin'* the industry's first true driving simulation game, plus many more new features.

### New Features

*Improved Handling* — Faster microprocessor and more efficient software code provides a now imperceptible lag time between control input and screen graphic response. Race Drivin' feels even more like a real car!

*New Tracks* — The Super Stunt track will challenge even the best *Hard Drivin'* stunt racers. New tests of skill include a corkscrew loop, a jump loop, and a full pipe.

The autocross track with a built-in pace car provides feedback to hone competitive driving skills. The vector-drawn pace car is actually a recorded view of the player's best lap.

*Buddy Race* — Two-player sequential race in which the computer records the performance of player one, and player two races head-to-head against the first player and the clock.

*Linked Race* — Install a simple cable between two simulator cabinets, adjust game options, and the buddy race becomes a true head-to-head competition. Contact your Atari Distributor for details and software availability.

*Select a Car* — Players can select from several different sports cars to suit the race track chosen. The Race Drivin' cars are modeled after the performance features of several well-known sports cars. Each car has its own handling characteristics of off-the-line quickness, top speed, and cornering.

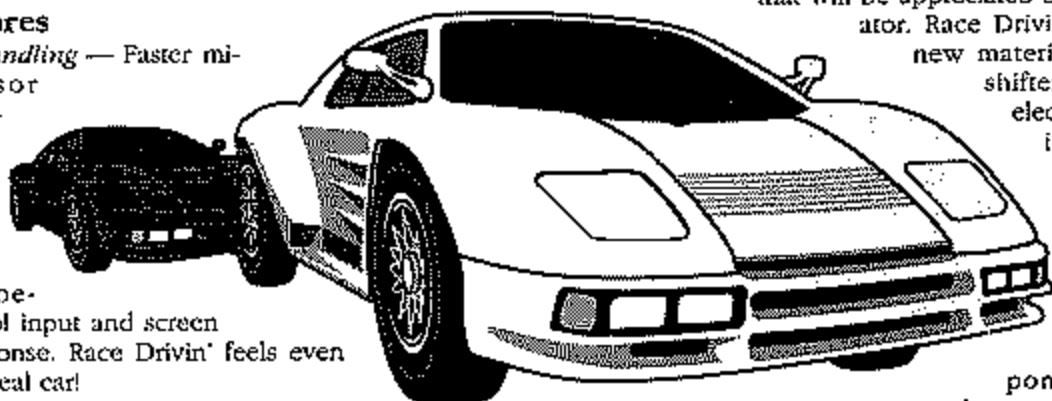
In addition to all of the innovations aimed at the player, Atari has also included many improvements that will be appreciated by the operator.

Race Drivin' includes new materials for the shifter boot and electromechanical parts.

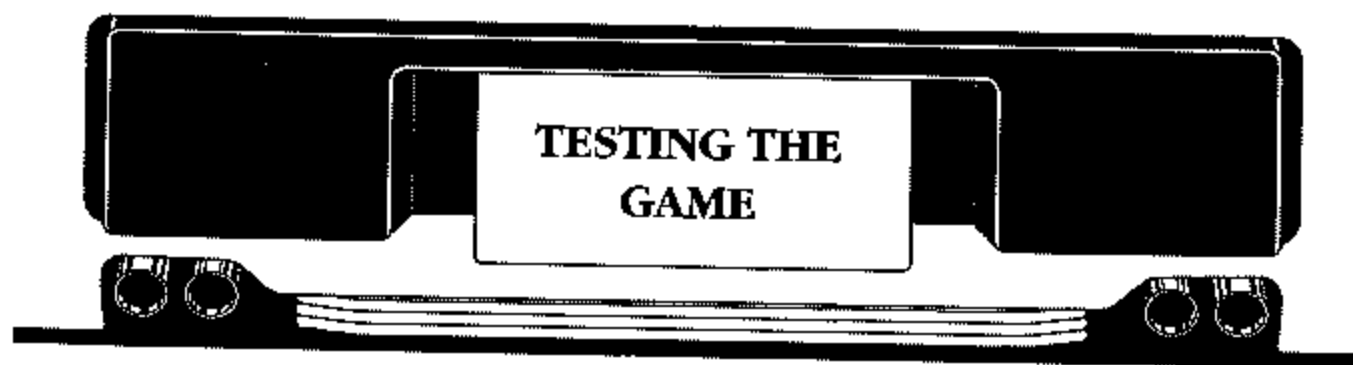
There is also improved serviceability for major components such

as the steering motor

and pedal assemblies. Little touches such as easier access to the cash box and servicing of the key start switch have been designed into the new cabinet.



# Self-Test



The *Race Drivin'* simulator is a complex machine. To keep it at peak efficiency and maximum earnings, you should regularly check the controls, RAMs, ROMs, PCBs, and microprocessor systems. You can check all of these when you switch on the self-test. Also in the self-test you can check the video display, the statistics, and set the internal clock.

If you cannot use the self-test because the screen is dark, you can use a DIP switch on the main PCB to find the source of the problem. If you are having electronic problems, you can check the state of various signals with the LEDs on the main PCB.

You should regularly check the following screens and information. We recommend you check these when you first set up the simulator, each time you collect money, or when the simulator is not working correctly.

- Use the automated self-test, which begins automatically when you turn on the self-test to test the program RAMs and ROMs, the video RAMs, color RAMs, the DSK PCB, the ADSP PCB, and the sound

PCB. The test takes about 5 minutes to run.

- Check the *Control Inputs* screen, which you choose from the *Test Menu* screen. This shows the voltage input to the main PCB from the steering wheel, brake pedal, gas pedal, clutch pedal, seat, and shifter. With this information you can easily check how the controls are working.

## NOTE

*If the control inputs are wrong, your earnings may drop, since the realistic driving feel is lost.*

- Check the *Statistics, Histogram, and Games Played by Day and Hour* screens which show the statistical information about how and when your simulator is played.

Table 2-1 shows you what tests and screens to use at different times and for different problems. ☺ ☺ ☺ ☺

## Entering and Exiting the Self-Test

You enter and exit the automated self-test procedure by turning the self-test switch on or off. The switch is located at the back of the upper coin compartment. You run the tests with the door open so that you can press the right and left coin switches to move up and down the menus.

The self-test consists of:

- A five-minute automated self-test of the ROM, RAM, the microprocessor, and the PC boards
- A Test menu from which you can run specific tests in the event that you receive error messages

If you are running a specific test and turn off the self-

test switch to exit, you may need to proceed through all the screens in the submenu and return to the Test menu before you return to the attract mode.

## Automated Self-Test

When you enter the self-test, the simulator automatically tests the program ROM and RAM, the video RAM, the color RAM, the DSK PCB, the ADSP PCB, and the sound PCB.

### NOTE

*If you do not see anything on the video display screen, you may have a video display problem or a simulator system problem. See DIP Switches at the end of this chapter to diagnose the problem.*

**Table 2-1 Using the Self-Test Screens and Diagnostics**

| Problem or Type            | Explanation  |
|----------------------------|--|
| Automated Self-Test        | When you switch on the self-test, the automated self-test is performed. This tests the program RAM and ROM and the PCBs. You can skip the self-test by turning and holding the key as soon as you enter the self-test.<br>If you cannot run the self-test at all, use the DIP switches to diagnose the problem. These are explained at the end of this chapter.  |
| Test Menu                  | Appears after the automated self-test. Select tests and information on this screen.  |
| Regular Maintenance        | Regularly do the following:<br>1. Do the automated self-test.<br>2. Check the <i>Operator Screens</i> .<br>3. Go to the <i>Control Inputs</i> screen to test the controls.   |
| Game Set-Up                | When you first set up your game, do the following:<br>1. Do the automated self-test.<br>2. Make sure the options on the <i>Operator Screens</i> are set correctly for your location, or set to the defaults.<br>3. Go to the <i>Control Inputs</i> screen to test the controls.<br>4. Set the clock, if necessary, using the <i>Set Time</i> screen.   |
| Control Problem            | 1. Do the <i>Set Controls</i> screens.<br>2. If that does not correct the problem, go to the <i>Control Inputs</i> screen and see if the input from the control changes as you use the control.<br>3. Go to Chapter 3 and check the troubleshooting table and maintenance information for that control.<br>4. If the shifter, brake, clutch, or seat potentiometer is broken and you cannot fix it immediately, but still want to operate the game, turn off the control circuit in the <i>Disable Broken Controls</i> screen. |
| Video Display Problem      | 1. Try the <i>Monitor Test Patterns</i> screens.<br>2. If you cannot go into the self-test or the screen is dark, use the DIP switch diagnostics.  |
| Electronics Problems       | 1. Do the automated self-test.<br>2. Choose the <i>Special Functions</i> screen that applies to your problems: the GSP, program ROM, ADSP PC board, sound PC board, or DSK PC board test.  |
| Game Clock                 | Use the <i>Set Time</i> screen to set the internal game clock. This time is used in the statistics screen that shows games played by day and time and in the schedule for clearing the high score table.   |
| Cannot Enter the Self-Test | Use the DIP switches and the LEDs to diagnose the problem. These are explained at the end of the chapter.  |

The automated testing takes about five minutes. The results appear on the screen. Messages in red alert you to a problem. You can run further testing from the Test menu.

If you do not want to wait for the systems and PCBs to be tested, you can skip these tests by turning the ignition key while in the program ROM and RAM screen, Figure 2-1. (If the self-test proceeds beyond this screen, it will run its course.) If you want to exit to the attract mode, just turn the self-test switch off.

## Program ROM and RAM Test

When you enter self-test, the simulator tests the program ROM and RAM. The screen in Figure 2-1 shows the results of a program ROM and RAM test.

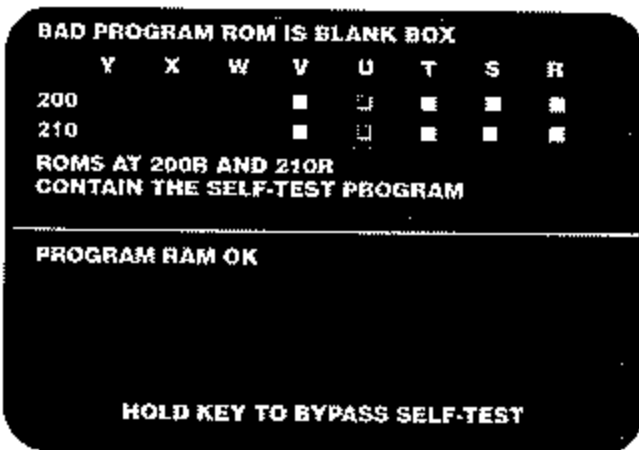


Figure 2-1 Program ROM and RAM Test Screen

The top of the screen shows the ROM test result. The numbers on the left and the letters on the top of the screen show the locations of the ROMs on the main PCB. If a white box appears, then the ROM there is good. If an empty box appears (as shown at 200U and 210U), then the ROM there is bad. If nothing appears, then nothing was tested there.

The RAMs are tested after the ROMs. If the RAMs have no errors, then you see the message *Program RAM OK*. If the test finds an error, then you see *Bad Program RAM At* with the bad RAM location listed.

This screen disappears after a few seconds and the self-test continues. However, the screen with the results of the complete self-test, shown in Figure 2-2, shows the message *Bad Program ROM* (or *Bad Program RAM*) if it found an error in the program ROMs or RAMs.

## Microprocessor and Board Tests

After checking the program RAM and ROM, the automated self-test checks the simulator's microprocessor and PC boards. It tests the video RAM and color RAM in the GSP microprocessor system, the DSK board, the ADSP board, and the sound board. The test takes four to five minutes. You see the screen in Figure 2-2 when the test finishes.



Figure 2-2 Microprocessor and Board Tests Screen

If the system or board is good, *OK* follows the test name. If it is bad, the word *Bad* precedes the name of the board or system (except for the ADSP board test, which gives more information). If you have a bad system or board, then choose *Special Functions* from the Test menu, choose the appropriate system or board tests from the Special Functions menu, and read the description of the tests in this chapter.

Here is a brief description of each microprocessor and board test performed during the automated self-test.

**PROGRAM ROM:** Described above.

**PROGRAM RAM:** Described above.

**GSP VRAM:** Uses the Simple GSP VRAM Test. (Described in the section *Main Board GSP Tests*.)

**GSP COLOR RAM:** Uses the GSP Color RAM Test. (Described in the section *Main Board GSP Tests*.)

**DSK Board:** Tests two ASIC systems, the DSK Program RAM, the DSK ZeroPower RAM, and the DSK Program ROM. These tests are described in the section *DSK Board Tests*.

**ADSP Board:** Tests the ADSP board memory and the ADSP-2100. Most of the error messages are self-explanatory. (*Does Not Respond* generally indicates a missing board.)

**Sound Board:** Tests the sound program ROM and

RAM, the sound board communications ROM and the 32010 ROM.

**Sound Wave ROMS:** Tests the ROMs that have the sound waveform data. If any are bad, the message *Bad Sound Wave ROMs* appears on the screen.

**Steering Wheel Motor Test:** Performs a simple test of the steering wheel system.

## Test Menu Screens

After the microprocessor and board test is finished or you bypass it, turn the key to proceed to the Test menu. The Test menu screens let you conduct specific troubleshooting in the event of problems.

Turn the key once to see a screen that explains how to select from the Test menu, shown in Figure 2-3. Turn the key again to see the Test menu, shown in Figure 2-4.

As the screen shown in Figure 2-3 explains, you use the right and left coin switches and the ignition key to

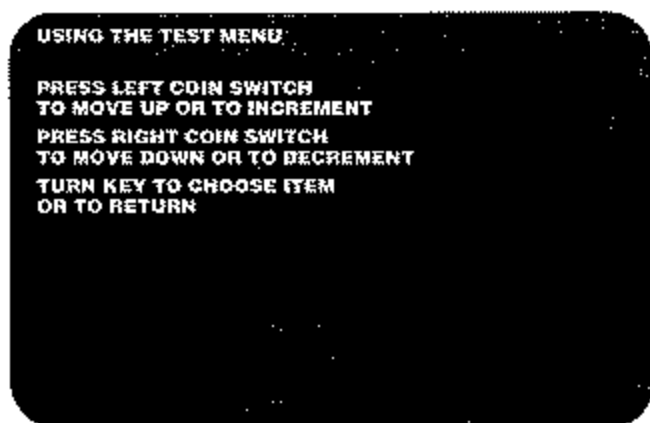


Figure 2-3 Instructions for Test Menu Screen



Figure 2-4 Test Menu Screen

make a selection from the Test menu. Pressing the right or left coin switch on the back of the upper coin door moves you up or down the menu. When the option you want is white, turn the ignition key to select it. The submenus for the specific tests work the same way.

The Test menu, shown in Figure 2-4, is the most important screen in the self-test. Use this screen to choose specific tests to pinpoint problems and to set the game options. Table 2-4 shows all the tests that are available from the Test menu.

## Operator Screens

Choose Operator Screens from the menu by pressing the right or left coin switch until this item is white, then turn the ignition key to select it.

If you are in the operator screens and want to go to the attract mode, first turn the key to go through the remaining operator screens. When you return to the Test menu, turn off the self-test switch.

The Operator Screens let you set game options and monitor the use of the simulator. The choices on the Operator Screens submenu are:

- Coin Options
- Link Options
- Game Options
- Statistics
- Histograms of Game Times
- Error Count
- Games Played by Day and Hour

## Coin Options

The first operator screen, Coin Options, lets you reset the coin credits (see Figure 2-5).

To reset the coin options:

- Move up or down the list by pressing the right or

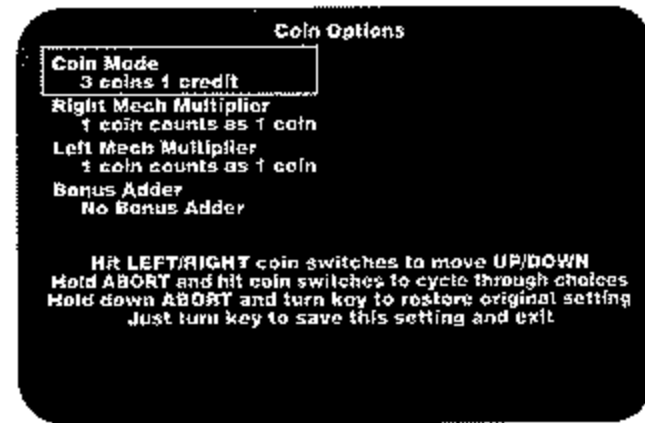


Figure 2-5 Coin Options Screen



left coin switch. A blue box indicates which item is selected.

- Press the Abort button and either coin switch to scroll through the settings until you see the one you want.
- To return to the original settings, press the Abort button and turn the ignition key.
- When through, turn the key to exit the screen.

The default setting of each option is green. The available settings are listed in Table 2-2.

**Table 2-2 Coin Option Settings**

| Option                | Available Settings  |
|-----------------------|---|
| Coin Mode             | 1 coin/1 credit<br>2 coins/1 credit<br>3 coins/1 credit ♦<br>4 coins/1 credit   |
| Right Mech Multiplier | 1 coin counts as 1 coin ♦<br>1 coin counts as 4 coins<br>1 coin counts as 5 coins<br>1 coin counts as 6 coins   |
| Left Mech Multiplier  | 1 coin counts as 1 coin ♦<br>1 coin counts as 2 coins   |
| Bonus Adder           | No bonus adder ♦<br>2 coins give 1 extra coin<br>3 coins give 1 extra coin<br>4 coins give 1 extra coin<br>4 coins give 2 extra coins<br>5 coins give 1 extra coin<br>Free Play |

♦ *Manufacturer's recommended settings*

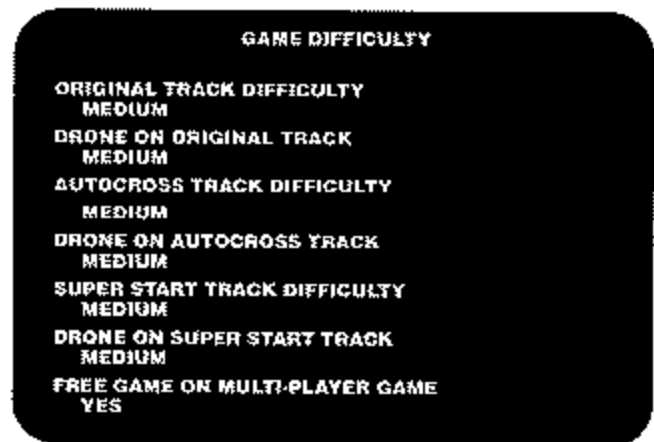
The Coin Options are as follows:

- *Coin Mode* is the number of coins required for one credit.
- *Right Mech Multiplier* is the number of coins each coin counts as in the right coin mechanism.
- *Left Mech Multiplier* is the number of coins each coin counts as in the left coin mechanism.
- *Bonus Adder* lets you choose bonus coins, no bonus, or free play.

## Game Difficulty

The game difficulty of each track and the difficulty of the drone car for each track can be set with this screen (Figure 2-6). In addition to settings of easy, medium, hard and very hard, custom tuning is provided. In the *Custom* setting, you can choose the actual amount of time a driver is given. You can select different times for each individual lap in this option.

The actual times for easy, medium, hard, and very



**Figure 2-6 Game Difficulty**

hard game difficulty settings are also shown in the custom settings. For example, if you have chosen the medium setting in *Game Difficulty*, then the custom screen appears as shown in Figure 2-7.

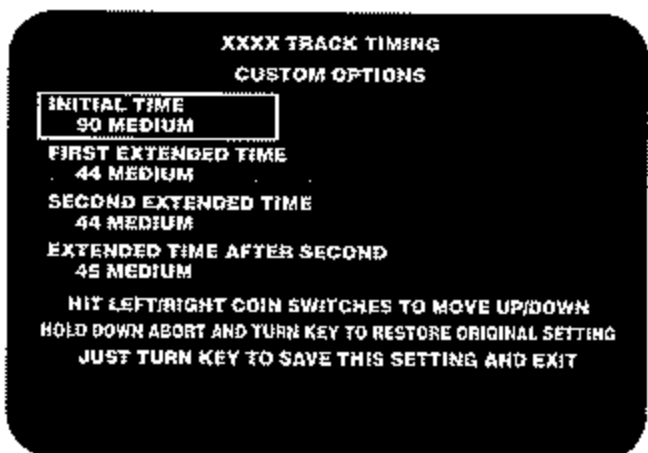
### NOTE

*Always use the preset Game Difficulty settings before you use the settings of the Custom game options.*

To move and choose in this screen, do the following:

- To move up or down the list, press the right or left coin switch.
- To change a setting, press the abort button and either coin switch.
- To return to the setting that was originally on the screen, press the abort button and turn the key.
- To exit the screen, turn the key.

You can change an option when it is inside the blue



**Figure 2-7 Custom Game Options Screen**

Table 2-3 All Screens Appearing in the Self-Test

| Screen                         | Use  |
|--------------------------------|--|
| <b>Automated Self Test</b>     |  |
| Program RAM and ROM            | Tests the program RAM and ROM.   |
| Automated Self-Test Results    | Shows results of the program RAM and ROM, VRAM, color RAM, MSP DRAM, ADSP PCB, and sound PCB tests.  |
| <b>Test Menu Screens</b>       |  |
| Instructions for Test Menu     | Information about using the test menu.   |
| Test Menu                      | List of available tests and information you can choose.  |
| <b>Operator Screens</b>        |  |
| Coin Options                   | Sets the coin options.   |
| Game Difficulty                | Sets track and drone difficulty.   |
| Track Timing                   | Use preset game options first.   |
| Game Options                   | Sets the game options, controls the high score table and steering in the attract mode.   |
| Statistics                     | Shows game statistics.   |
| Histograms                     | Shows game histograms, and number of games by length of play.  |
| Error Count                    | Shows the error count from the PC boards. Used by the factory for debugging.   |
| Games Played by Day and Hour   | The simulator clock must be set correctly to get maximum use from this screen.   |
| <b>Set Controls</b>            |  |
| Initialize Pot Inputs          | Use if you are having any control problems or replace or repair a control or a PCB. Initializes all the simulator potentiometers.  |
| Initialize Steering Limits     | Sets the steering limits.  |
| Initialize Shifter Limits      | Sets the shifter limits.   |
| Initialize Seat Limits         | Sets the seat movement limits.   |
| Initialize Force Brake         | Sets the limit on the force on the brake.  |
| <b>Control Inputs</b>          | Check this screen <i>regularly</i> to make sure your controls are operating correctly.   |
| <b>Monitor Test Patterns</b>   |  |
| Color Bars                     | Use these screens to check the performance of your video display. Shows the video display colors.  |
| Monitor Adjust                 | Shows the video display colors.  |
| Monitor Brightness             | Used for the monitor setup.  |
| Grey Scale                     | Shows the brightness adjustment.   |
| B/W Dots                       | Shows the grey scale of the video display.   |
| B/W Grid                       | Shows convergence and focus of the video display.  |
| Diagonal Lines                 | Shows convergence and focus of the video display.  |
| Full Screen Grey               | Shows linearity of the video display.  |
| Full Screen White              | Shows the color purity of the video display.   |
| Full Screen Red                | Shows the color purity of the video display.   |
| Full Screen Green              | Shows the color purity of the video display.   |
| Full Screen Blue               | Shows the color purity of the video display.   |
| Monitor High Voltage Test      | Checks the regulation of the high voltage to the video display.  |
| Scrolling Test                 | Checks the scrolling mechanism of the GSP microprocessor.  |
| <b>Set Clock</b>               | Set the time so that you can get maximum use from the <i>Games Played By Day and Hour</i> screen and so that the high score table reset occurs at the right time.  |
| <b>Disable Broken Controls</b> | If you cannot repair a broken shifter, brake, clutch or seat potentiometer immediately, you can disable that control's circuit so you can continue to operate the game. <i>Repair the broken control as soon as possible. Use this screen only as a temporary measure.</i> |

Table 2-3 All Screens Appearing in the Self-Test, Continued

| Screen                          | Use  |
|---------------------------------|--|
| <b>Special Functions</b>        | Use this screen for tests of the controls, PCBs, and microprocessors.  |
| <b>Main Board GSP Tests</b>     | Use this screen if you have a VRAM failure in the automated self-test.   |
| VRAM Simple Test                | Checks for bad VRAMs in the GSP microprocessor system.   |
| VRAM Verify Test                | Tests all the VRAM GSP memory.   |
| VRAM Complete Test              | Completely tests all VRAM.   |
| Color RAM                       | Tests the color RAM.   |
| VRAM Shift Register Test        | Checks the VRAM shift register.  |
| <b>Main Board Controls</b>      | Shows much the same information as the <i>Control Inputs</i> screen, but has additional tests for the steering wheel, shifter, and line voltage calibration. |
| Pots: 8 Bit                     | Shows the gas pedal, clutch pedal, seat movement, shifter movement, steering wheel movement, line voltage and the shifter force input to the main PCB.       |
| Pots: 12 Bit                    | Shows the steering wheel movement and the brake force input to the main PCB.   |
| Steering Wheel                  | Use if the steering wheel does not work. See the steering wheel flow charts in Chapter 3 for information about their use.                                    |
| Send Force                      | Use this test as directed in the flowchart in Chapter 3.   |
| Sine Wave                       | Sends a sine wave force to the motor amplifier PCB.  |
| Square Wave                     | Sends a square wave force to the motor amplifier PCB.  |
| Triangle Wave                   | Use this test as directed in the flowchart in Chapter 3.   |
| Closed Loop Test                | Sends a force to the motor amplifier PCB simulating a simple spring.   |
| Line Voltage Calibration        | Calibrates the line voltage display in the self-test.  |
| Opto Test                       | For factory use only.  |
| Life Test                       | For factory use only.  |
| Shifter                         | Use this screen if the shifter does not work correctly.  |
| Link Connector                  | Use this screen if the game link does not work correctly.  |
| <b>Main Board ROM Checksums</b> | Use this test if the program ROMs fail the automated self-test.  |
| <b>Main Board ZRAM Tests</b>    | Check the ZRAMs. Use this if all the controls are operating erratically or the statistics are not kept correctly.  |
| <b>ADSP Board Tests</b>         |  |
| ADSP RAM .TESTED BY 68010.      | Use this test if the ADSP board fails the automated self-test.   |
| ADSP PROGRAM MEMORY TEST .2100. | The 2100 runs a standard, complete test on its own program memory.   |
| ADSP DATA MEMORY TEST .2100.    | The 2100 runs a standard, complete test on its own data memory.  |
| 2100 Test                       | Tests the response of the 2100 integrated circuit on the ADSP PCB.   |
| IRQ Test                        | Tests if the ADSP system can generate IRQs.  |
| ROM Checksums                   | Tests the graphics ROMs on the ADSP PCB.   |
| ADSP Special Functions          | Performs hardware diagnosis and oscilloscope test loops for use by a repair technician.  |
| <b>Sound Board Tests</b>        | Use these tests if the sound board fails the automated self-test.  |
| Sound Board Self-Test           | Tests the sound program RAM and ROM, COMRAM and the 320 RAM.   |
| Play Sounds                     | Choose and hear game sounds.   |
| Sound Board ROM Checksums       | Tests the sound PCB ROMs.  |
| Sound Board Program RAMs        | Tests the sound PCB program RAMs.  |
| Sound Board Program ROMs        | Tests the sound PCB program ROMs.  |
| COMRAM                          | Tests the sound PCB communication ROM.   |
| 320 RAM                         | Tests the sound PCB 32010 program RAM.   |

box. The default setting of each option is green. The other settings are blue when the option is selected. (The other settings are white when the option is *not* selected.)

The custom game options are explained below.

- *Initial Time* is the amount of time always given for one driving session.
- *First Extended Time* is the amount of time given if the driver crosses the finish line before the initial time is up.
- *Second Extended Time* is the amount of time given if the driver crosses the finish line before the time is up on his second lap.
- *Extended Time After Second* is the amount of time given when the driver crosses the finish line before the time is up after the first two laps.

## Game Options

Use the Game Options screen to set the game difficulty and the operator options as explained below. The screen is shown in Figure 2-8.

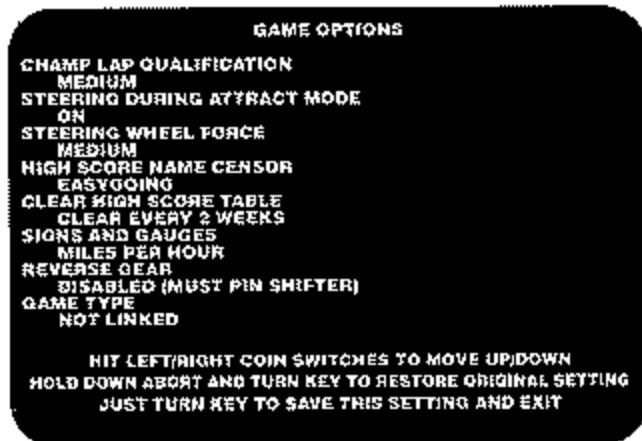
You operate this screen the same as Coin Options. Press the coin switch to select an option, and press Abort and a coin switch to scroll to the setting you want. Turn the key to save the settings and exit. A list of the available settings is shown in Table 2-4.

The Game Options available on this screen set the following:

- *Game Difficulty* sets the game difficulty for the drivers. The settings are shown in Table 2-4. The *custom* setting lets you choose the actual amount of time the players receive. We suggest you use the

**Table 2-4 Game Option Settings**

| Option                       | Available Settings    |           |
|------------------------------|-----------------------|-----------|
| Champ Lap Qualification      | Easy                  | Medium ♦  |
|                              | Hard                  | Very Hard |
| Steering During Attract Mode | On ♦                  | Off       |
| Steering Wheel Force         | Very Light            | Light     |
|                              | Medium ♦              | Stiff     |
| High Score Name Censor       | Easygoing ♦           | Strict    |
| Clear High Score Table       | Don't Clear           |           |
|                              | Clear Now             |           |
|                              | Clear Every Week      |           |
|                              | Clear Every 2 Weeks ♦ |           |
| Signs and Gauges             | Miles per Hour ♦      |           |
|                              | Kilometers per Hour   |           |
| Game Type                    | Available Soon        |           |



**Figure 2-8 Game Options Screen**

preset factory setting (easy, medium, hard, and very hard), not the custom setting.

- *Champ Lap Qualification* sets the difficulty of qualifying for the championship lap.
- *Steering During Attract Mode* allows you turn the movement of the steering wheel on or off while the simulator is in the attract mode.
- *Steering Wheel Force* is the amount of force exerted by the steering assembly motor on the steering wheel.
- *High Score Name Censor* controls a program to censor names entered on the high score table. The program deletes letters in possibly objectionable words in the high score table.
- *Clear High Score Table* clears the high score table at the time chosen. You can choose not to clear the table, clear it now, clear every week, or clear every two weeks. If you choose clear every week or clear every two weeks, the table is cleared when the simulator is turned on after Wednesday midnight every week or every second week. Be sure your simulator clock is set correctly so the table clears at the right time.
- *Signs and Gauges* allows you to choose whether the signs and gauges are displayed in kilometers or miles.

## Statistics

The statistics screen is shown in Figure 2-9. The statistics are collected from the last time the statistics screen was cleared. Write this information on the statistics sheet in the back of this manual to help you maximize your profit.

To move to the next screen, just turn the key. To clear the statistics, press and hold the abort button and turn

the key at the same time.

The statistics the simulator collects are explained below.

- **Left Coins** shows the number of coins counted in the left coin mechanism.
- **Right Coins** shows the number of coins counted in the right coin mechanism.
- **Aux Coins** shows the number of times the auxiliary coin switch (inside the coin door) is pressed.
- **Idle Mins** shows the number of minutes the simulator has been idle.
- **Active Mins** shows the number of minutes the simulator has been played.
- **Error Count** shows the number of errors counted in the erasable memory. If you have more than 75, check the ZRAMs with the self-test. Your simulator may need service.
- **Total Games** shows the number of unique games played.

#### Bottom Half of Screen

For the remaining statistics (except for the five entries at the very bottom of the screen), the three numbers after each entry represent, from left to right: first — original track at the beginning, second — autocross track, and third — super stunt track.

- **Laps by Track** is numbers of laps, completed or not, on each track.
- **No X Games by Track** is the number of times the drivers did not get extended games on either track. If the numbers are very high, then the game difficulty may be too hard.
- **1, 2, and 3+ X Play Games by Track** is the number of additional laps given to drivers if they complete the track before the time allotted. These additional laps do not need to be completed to be counted.
- **Champ Laps** is the number of times drivers qualified to race a championship lap.
- **2 Player Games by Track** is the number of games played with two players.
- **2 Player Time by Track** is the average time of all games played with two players.
- **Free Games by Track** is the number of free games played on each track.
- **Total Games by Track** shows the number of unique games for each track, regardless of how many additional laps each driver received.
- **Total Time by Track** shows the total time of all games for each track.

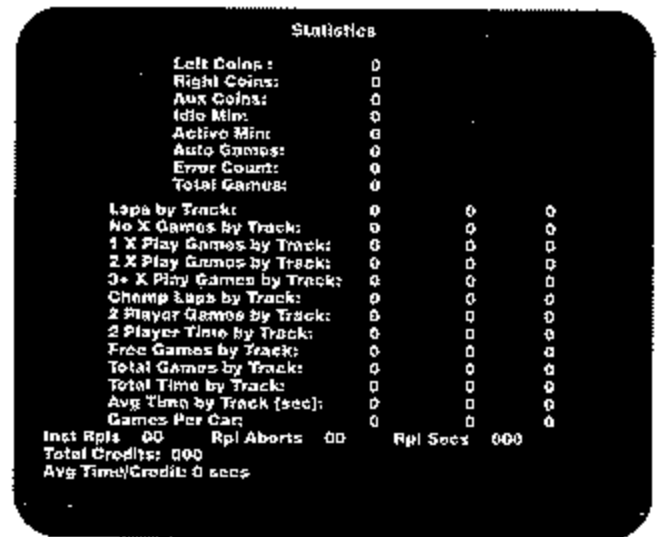


Figure 2-9 Statistics Screen

- **Avg Time by Track (sec)** shows the average total time of all games for each track.
- **Games by Car** shows the number of games played with each type of car.
- **Inst Rpls** is the total number of instant replays.
- **Rpl Abort** is the times the drivers pressed the abort button to cut the instant replay short.
- **Rpl Secs** is the total seconds the simulator is in the replay mode.
- **Total Credits** is calculated by multiplying the coins by the credit setting you chose in Coin Mode.
- **Avg Time Per Credit** is the average amount of time in seconds that each credit gave.

## Histogram

The histogram screen shows the length of driving time in seconds and the how many times the simulator was driven. The screen is shown in Figure 2-10. Write these numbers on the statistics sheet in the back of this manual to help you maximize your profit.

To move to the next screen, turn the key. To clear the histograms, press and hold the abort button and turn the key at the same time.

## Error Count

This screen shows the error count on the PC boards. If you call Atari Game Customer Service, the numbers on this screen may help Customer Service personnel troubleshoot your problem.

## Games Played By Day and Hour

This screen, illustrated in Figure 2-11, shows the number of games played every hour in each day. The information on this screen relies on the simulator clock being set correctly. (The clock time is shown on the bottom of the Test menu screen. If the time is incorrect, follow the instructions in the *Set Clock* section of this chapter to set the clock.)

Write the simulator driving information on the statistics sheet in the back of this manual to help you maximize your profit.

To clear the screen, press and hold the abort button and turn the key at the same time.

## Set Controls Screens

If you have problems with a control in the simulator, use the *Set Controls* screens before doing any troubleshooting or repairs. These screens allow you to set the beginning and ending points of the control input to the main PCB. Often, resetting these points will solve the problem you have. If resetting does not solve the problem, then check the *Control Inputs* screen, described below.

If you repair a control, then when you put the control back in the simulator, go through the *Set Control* screens. If you install a new board or a new control, you must go through the *Set Control* screens too.

The first *Set Controls* screen is shown in Figure 2-12.

### NOTE

*If you take a control out of the simulator for repair or maintenance, you must go through all the Set Controls screens after you replace it. If you do not, the simulator will not operate correctly.*

After you choose *Set Controls*, simply do what the screens say. You must reset all the controls after you start the screens. The first screen initializes all potentiometers in the simulator. (The steering wheel, shifter, seat, gas, and brake have potentiometers.) The next screens initialize the limits for the steering wheel, shifter, seat, and brake. The numbers on each screen are for factory use.

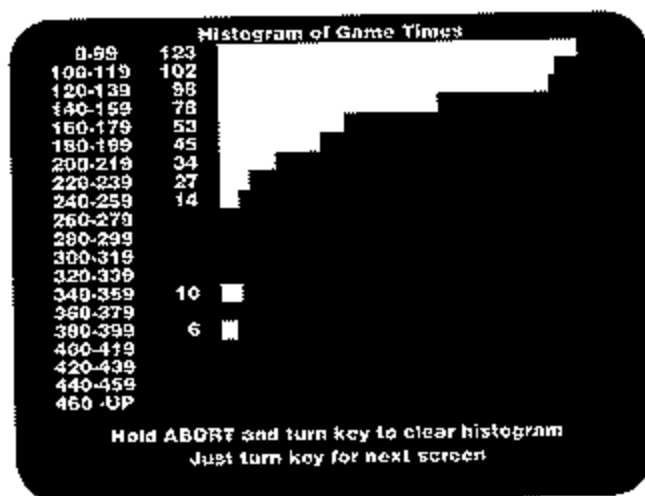


Figure 2-10 Histogram Screen

### NOTE

*When you initialize the brake, the instructions say to "step firmly" on the brake. Do not stomp on the brake or gently press it. Either way sets the brake limits incorrectly and drivers will be frustrated when they use the brake.*

## Control Inputs Screen

Check this screen as part of your regular maintenance to be sure your controls are operating correctly.

The *Control Inputs* screen is shown in Figure 2-13. This screen shows the voltage inputs from the control potentiometers to the A/D converter circuits on the main PC board. As you use a control, the line length on the screen changes, showing the change in the voltage input from the potentiometer. If the line length does not change, you have a problem.

If you have a problem, first go through the *Set Controls* screens to see if that solves the problem. Check the results on the *Control Inputs* screen. If using the *Set Controls* screens does not solve the problem, check Chapter 3 for troubleshooting and repair information.

The first control on the screen is the *Steering Wheel*. This line shows the movement of the steering wheel. As you turn the steering wheel counterclockwise, the line should disappear.

The second line is *Brake Force* which measures the force with which the brake is pushed. As you push harder and harder on the brake, its line should disap-

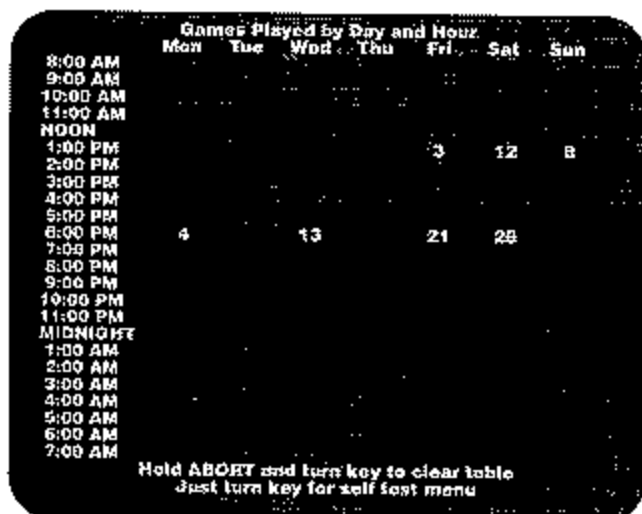


Figure 2-11 Games Played by Day and Hour Screen

pear.

In both of these lines, 0 Volts appears as no line or a short line on the screen, and 5 Volts appears as almost eight full lines on the screens.

Below these two lines are the gas pedal, clutch pedal, seat movement, shifter (front to back), shifter (left to right), steering wheel, line voltage, and shifter force. (The steering wheel movement is checked with two lines.) As you use the controls, the lines should become longer and shorter. If the line does not move, then see Chapter 3 for more information. (The line voltage varies at 60 Hz. You cannot test the line voltage.)

For these controls, 0 Volts input appears as no line or a short line on the screen and 5 Volts appears as a line halfway across the screen.

At the bottom of the screen, you can check the left and right coin mechanism, the auxiliary coin switch behind the coin door, and the seat magnet. Use the

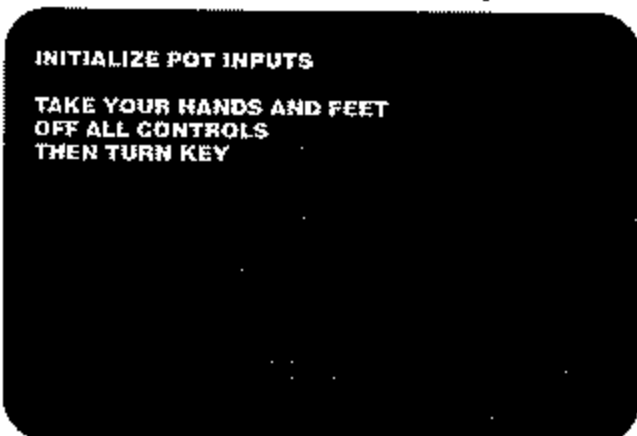


Figure 2-12 First Set Controls Screen

seat magnet test to determine whether the seat is locking as it should and if the magnet is good.

If the seat has not been working correctly, but does lock in this test, the switch probably should be repaired or replaced. If the seat does *not* lock, then your problem is probably the harness or the magnet.

## Monitor Test Patterns

Use this item to see the fourteen screens for checking the video display, the color RAMs, the GSP, which controls the video RAMs (VRAMs), and the video output. To move through the screens, press the coin switches.

- *Color Bars* screen shows these colors from left to right: white, yellow, light blue, green, purple, red, blue, and grey. If the colors are incorrect, see your video display manual for adjustment procedures.
- *Monitor Adjust* is used to set up the monitor.
- *Monitor Brightness* checks the adjustment of the video display brightness.
- *Grey Scale* screen shows a white line on the left, and a grey scale showing black on the left.
- *B/W Dots* screen can be used to check convergence and focus.
- *B/W Grid* screen, shows a black background and a white grid pattern to check convergence. The grid lines should be straight within 3.0 mm. If you need to adjust the convergence, see the video display manual included with the simulator.
- *Diagonal Lines* screen can be used to check video display linearity.
- *Full Screen* colors test the color purity of the color

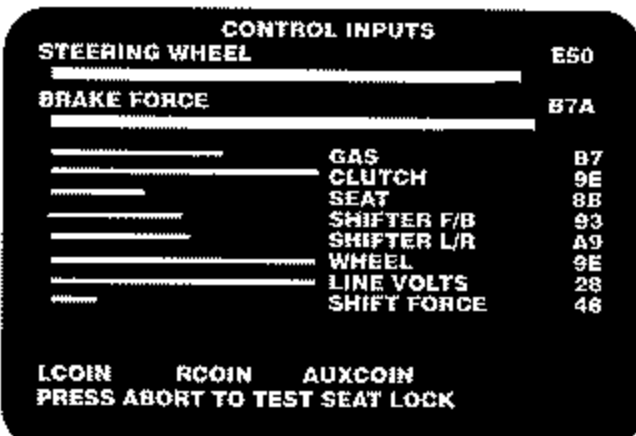


Figure 2-13 Control Inputs Screen

RAMs and the display. The test displays a grey, white, red, green, and then blue screen. Each screen should be a rectangle of color, with no curving at the corners and no lines in the raster. If it does not, see your video display manual included with the simulator for adjustment procedures.

- *Monitor High Voltage Test* screens switch between a white screen and a grey screen. If the high voltage to the display is regulated properly, the sides of the screen will fluctuate about 3/4 inch from the white to the grey screen.
- *Scrolling Test* screen checks the scrolling mechanism in the GSP.

## Set Clock Screen

Choose this item if you want to set the clock, turn the clock on, or turn it off. The clock should be set correctly so the statistics on the operator screen *Games Played by Day and Time* will be right.

The time on the clock also determines when the high score table is cleared. If you set the *Clear High Score Table* option in the *Game Options* screen to clear every week or every other week, then the high score table is cleared the first time the simulator is turned on after Wednesday midnight.

You may need to turn on the clock if the simulator has a program crash. Turn off the clock only if you plan to store the simulator more than six months. (The clock has a lithium battery that should last more than five years in normal use.)

To turn off the clock, choose *Clock Off* from the clock submenu, shown in Figure 2-14. To turn on the clock, choose *Start Clock* from the menu. In about two seconds, the clock starts.

If the clock is losing or gaining time, then use *Clock Faster* or *Clock Slower* to adjust the calibration of the clock.

Choose the item you need from the menu by using either coin switch. Change the setting by turning the key until you see the correct time.

The items on the clock menu are explained below.

- *Exit* returns you to the Test menu.
- *Inc Hours* changes the hour setting ahead.
- *Inc Minutes* changes the minute setting ahead.
- *Inc Seconds* changes the second setting ahead.
- *Inc Day* changes the day of the week (for example, Monday or Tuesday) setting ahead.
- *Inc Month* changes the month setting ahead.
- *Inc Date* changes the date setting ahead.

- *Inc Year* changes the year setting ahead.
- *Faster Clock* changes the calibration setting ahead. Each increase in the calibration setting makes the clock run about 5 seconds faster per month.
- *Clock Off* turns the clock off.
- *Dec Hours* changes the hour setting back.
- *Dec Minutes* changes the minute setting back.
- *Dec Seconds* changes the second setting back.
- *Dec Day* changes the day of the week (for example, Monday or Tuesday) setting back.
- *Dec Month* changes the month setting back.
- *Dec Date* changes the date setting back.
- *Dec Year* changes the year setting back.
- *Slower Clock* changes the calibration setting back. Each decrease in the calibration setting makes the clock run about 5 seconds slower per month.
- *Start Clock* starts the clock.

## Disable Broken Controls Screen

Use this screen, shown in Figure 2-15, if you have a broken shifter, brake pedal, clutch pedal, or seat potentiometer and cannot repair it immediately. Before you use this screen use the *Set Controls* screens and read the information about the control in Chapter 3.

Disable these controls *only* as a *temporary* measure so you can continue to operate the simulator while waiting for parts. If you disable a control, the realistic driving feel of that control is lost. *Earnings could drop.*

When you disable a control, the control circuit is overridden, and the simulator compensates for the loss of the control. If you have disabled a control, remember



Figure 2-14 Set Clock Screen



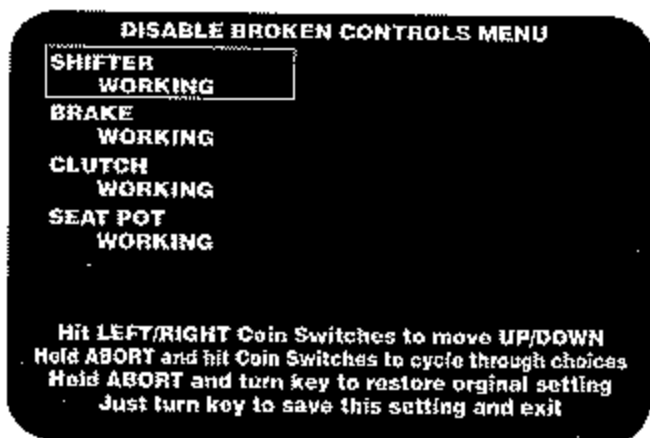
to choose *working* after you repair it so the control works correctly.

## Special Functions Screens

Use the items on this screen, shown in Figure 2-16, if a system or board failed the program RAM and ROM test or the board and microprocessor test in the automated self-test. Also use this screen if you have problems with the steering wheel, the shifter, or if the clock settings or the statistics are erratic. A short summary of when to use these items is shown in Table 2-5.

The *Special Functions* items are explained below.

- **Exit** returns you to the Test menu.
- **Main Board GSP Tests** should be used if you get the message *Bad GSP VRAM* or *Bad GSP Color RAM* in the automated self-test. This screen has six tests you can use.
- **Main Board Controls** gives you most of the same information as provided in the *Control Inputs* screen plus five steering wheel tests, a line voltage calibration screen, additional shifter tests, and a link connect test. (All controls are "main board" controls.)
- **Main Board ROM Checksums** should be used if you get the message *Bad Program ROM* in the automated self-test. This tests the program ROMs individually and shows the results on the screen.
- **Main Board ZRAM Tests** should be used if your controls settings are changing or erratic even though you used the *Set Controls* screen. Also use these tests if you suspect the simulator is not keeping the statistics correctly.
- **ADSP Board Tests** should be used if you get any message other than *ADSP Board OK* for the ADSP board test in the automated self-test. This screen has three tests and an ADSP ROM checksum test. It also has eight "scope loop" tests for factory use only since they require schematics and an oscilloscope.
- **Sound Board Tests** should be used if you get the message *Bad Sound Board* in the automated self-test. However, many of the sound board tests are for factory use only since they require schematics and an oscilloscope.
- **DSK Board Tests** should be used if you get the message *Bad DSK Board* in the automated self-test. This screen allows you to test the DSK ROMs, the DSK RAM, the DSK ZeroPower RAM (ZRAM), and the two ASIC subsystems. It also has a *Special Functions* screen for factory quality assurance.



**Figure 2-15 Disable Broken Controls Screen**

## Main Board GSP Tests

If the automated self-test reports bad VRAMs, choose *Main Board GSP Tests* and the screen in Figure 2-16 appears.

First run the VRAM simple test. It gives the location of the bad VRAMs. If the VRAMs pass this test, but you think the simulator has a bad VRAM, run the VRAM verify test.

- **VRAM Simple Test** is the same test that is run in the automated self-test. It is run by the 68010 through the GSP interface and detects open or shorted address or data lines or missing parts. The results are displayed on-screen with a picture showing the VRAM section of the main PC board. The good parts are shown in green and the bad parts are shown in red. If an entire section appears in red, the problem may be with a buffer associated with that section. The test takes about 30 seconds.
- **VRAM Verify Test** is a complete memory test run by the GSP. The results are reported on the screen like in the simple test. The test takes about three minutes to run.
 

Since the verify test is run by the GSP program in the VRAMs, a single bad VRAM can cause the GSP program to crash. When this happens, the 68010 microprocessor reports that all the VRAMs are bad, although probably only one VRAM is bad. You must run the VRAM complete test (described below) to find out which VRAM is bad.

If the VRAM verify test fails, but the VRAM simple test shows the VRAMs are good, you should run the VRAM complete test.

If the verify test runs and reports that the VRAMs are good, then the VRAMs should be good.
- **VRAM Complete Test** is a complete memory test run by the 68010 through the GSP interface. Because

**Table 2-5 When to Use the Special Function Items**

| Item                     | When to Use  |
|--------------------------|--|
| Main Board GSP Tests     | If you see the message <i>Bad GSP VRAM</i> or <i>Bad GSP Color RAM</i> in the automated self-test.   |
| Main Board Controls      | If you have control problems and/or game link problems.  |
| Main Board ROM Checksums | If you see the message <i>Bad Program ROM</i> in the automated self-test.  |
| Main Board ZRAM Tests    | If your controls settings are changing even though you have used the <i>Set Controls</i> screen or if the statistics are not being kept correctly. |
| ADSP Board Tests         | If you see any message other than <i>ADSP Board OK</i> for the ADSP PC board test in the automated self-test.                                      |
| Sound Board Tests        | If you see the message <i>Bad Sound Board</i> in the automated self-test.  |
| DSK Board Tests          | If you see the message <i>Bad DSK Board</i> in the automated self-test.  |

the 68010 runs the test, a single bad VRAM does not cause the test to report all the VRAMs are bad (as it does the verify test).

Any VRAMs that are bad are shown on the screen at the end of the test. This test takes at least 22 minutes to run.

- *Test VRAM for Display Errors* checks for video display problems.
- *Color RAM* is the same test that is performed in the automated self-test. It tests the color RAM and reports the results.
- *VRAM Shift Register Test* checks the shift register part of the video RAMs.

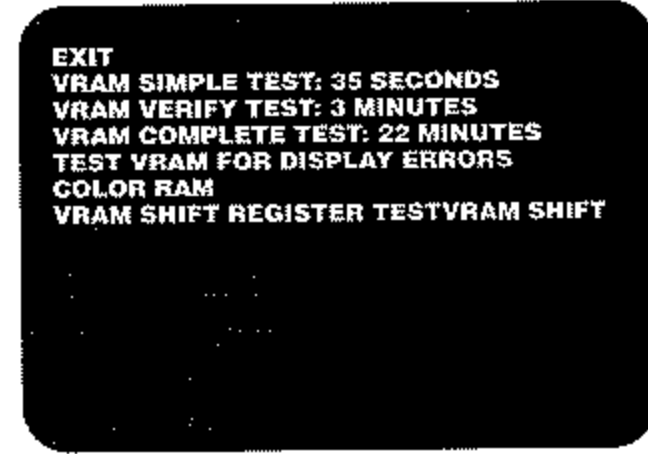
## Main Board Controls

This screen provides more information about the controls than is shown in the *Control Inputs* screen. The items on the screen are described below and shown in Figure 2-18. After you choose any item on this screen and go to that item, you can return to this screen by turning the key.

The *Pots: 8 Bit* and *Pots: 12 Bit* screens have the same information as the the *Control Inputs* screen. They show the voltage inputs from the control potentiometers to the A/D converter circuits. As you use a control, the line on the screen changes as the voltage input changes. If the voltage does not change, you should check that control according to the procedures in Chapter 3, *Maintenance and Troubleshooting*.

- The controls under the heading *Pots: 8-Bit* feed into the 8-Bit A/D converter circuit on the main PCB. (See Figure 2-19.) These controls are the gas pedal, clutch pedal, seat movement, shifter (front to back), shifter (left to right), steering wheel position, and shifter force. (The steering wheel position is also checked on the 12-bit A/D converter circuit. If the numbers do not match, the steering wheel force is turned off.)

As you use the controls, the lines should become longer and shorter. If the line does not move, then you have a problem with the control and you should see the information about the control in Chapter 3.

**Figure 2-16 Special Functions Screen****Figure 2-17 GSP Tests Screen**

In these controls, 0 Volts appears as no line or a short line and 5 Volts appears as a line halfway across the screen.

- In the *Pots: 12-Bit* screen, shown in Figure 2-20, *Steering Wheel* shows the position of the steering wheel. The steering wheel location input is sent to both the 12-bit and the 8-bit A/D converter circuits and is compared. If the numbers do not match, the simulator turns the steering motor force off.

*Brake Force* shows the force on the brake pedal. As you push harder and harder on the brake, the line disappears. If the line does not move, then you have a problem with the brake, the connection, or the A/D Converter circuit on the main PCB.

In the steering wheel and the brake force lines, 0 Volts appears as no line or a short line and 5 Volts appears as almost eight full lines drawn across the screen.

(The two lines on the bottom of this screen are not used.)

- *Steering Wheel* screen is explained below and shown in Figure 2-21.
- *Shifter* screen is described below and shown in Figure 2-23.
- *Duart* does not apply to this simulator.
- *Link Connector* tests the RS232 channel used to link two simulators together.

## Steering Wheel Submenu

Use these item if you believe you have a problem with the steering assembly or the motor amplifier assembly. The screen is shown in Figure 2-21. The section *Steering Assembly* in Chapter 3 explains how to use these tests.

### CAUTION

*Do not service the motor amplifier assembly, which is mounted on the left side of the cabinet. The assembly contains high voltage.*

*If you have a problem with the motor amplifier assembly return the entire assembly to your distributor for replacement.*

To move through the menu and the screens, use the coin switches. To exit a screen, push both coin switches down.

- *Exit* returns to the *Main Board Controls* screen.
- *Send Force* sends a steady force to the motor amplifier PCB. See Figure 2-22.

### MAIN BOARD CONTROLS

EXIT  
POTS: 8 BIT  
POTS: 12 BIT  
STEERING WHEEL  
SHIFTER  
DUART  
LINK CONNECTOR

Figure 2-18 Main Board Controls Screen

- *Sine Wave* sends a sine wave force to the motor amplifier PCB. This screen is similar to Figure 2-22.
- *Square Wave* sends a square wave force to the motor amplifier PCB. This screen is similar to Figure 2-22.
- *Triangle Wave* sends a triangle wave force to the motor amplifier PCB. This screen is similar to Figure 2-22.
- *Closed Loop Test* reads the steering wheel position and sends a force to the motor amplifier PCB to simulate a simple spring.
- *Line Voltage Calibration* can be used to calibrate the simulator voltage reading to the line voltage reading. Put a voltmeter on the line, then set the voltage on this screen to match.
- *Opto Test* is a test used by manufacturing.
- *Life Test* is a test used by manufacturing quality assurance.

### 8 BIT A/D

|       |             |    |
|-------|-------------|----|
| _____ | GAS         | 39 |
| —     | CLUTCH      | 07 |
| _____ | SEAT        | 8B |
| _____ | SHIFTER F/R | 95 |
| _____ | SHIFTER L/R | A9 |
| _____ | WHEEL       | EA |
| _____ | LINE VOLTS  | 28 |
| —     | SHIFT FORCE | 48 |

Figure 2-19 Pots: 8-Bit Screen

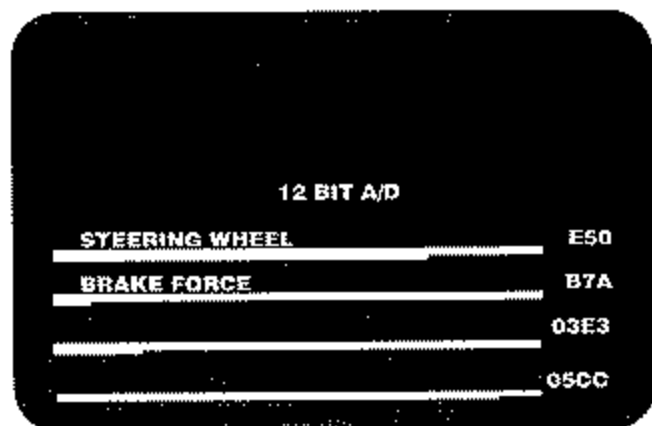


Figure 2-20 Pots: 12-Bit Screen

### CAUTION

*Do not use the Life Test. It is used only in the factory for testing of potentiometers. If you leave the simulator in this test for a long time, you can destroy the potentiometer on the steering assembly.*

## Shifter Test Screen

Use this screen if you have a problem with the shifter. Before you use the screen, see Figure 3-12, the shifter flowchart, to find out how to use the tests and settings on this screen. If you need to repair the shifter or the shifter PCB, see the shifter section in Chapter 3 for further information. The shifter screen is shown in Figure 2-23.

Under *Shifter Outputs*, you can see the voltage outputs change as you push the shifter from left to right and front to back. These numbers show the change in the voltage input from the shifter potentiometers to the 8-bit A/D converter circuit on the main PCB.

The *X Pot* number changes as you move the shifter handle from left to right. The *Y Pot* number changes as you move the shifter from front to back.

After *Shifter Power*, either a *0* or *1* will be displayed. Turning the start key switch on causes the shifter solenoid to be energized and the number *1* to be displayed. Releasing the key switch should display a *0*.

Exit the screen by pressing both coin switches simultaneously.

## Link Connector Test

Use this test if you have a problem when linking two simulators together. This test requires a special test connector plugged into the Link Connector on the game.

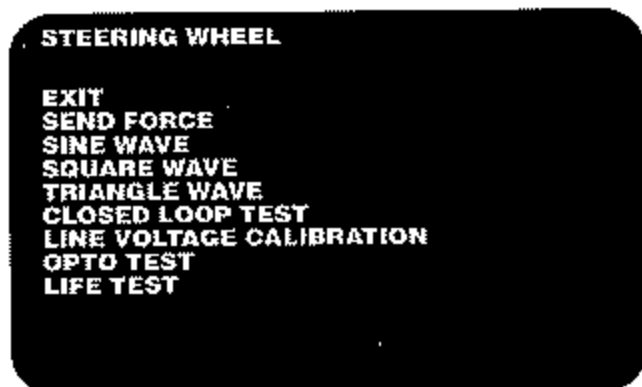


Figure 2-21 Steering Wheel Submenu Screen

The special test connector is a female DB-25 with pins 2 and 3 connected together. Contact Atari Games Customer Service on how to obtain a test connector.

The test results are displayed (in color) as shown in Figure 2-24.

## Main Board ROM Checksums

This screen checks the main PC board program ROMs for errors. Use this test if you have a bad program ROM message in the automated self-test or you suspect program ROM failure. To exit this screen, turn the key.

When the checksum test is complete, a hexadecimal number follows each ROM as shown in Figure 2-24. The first two digits in each hexadecimal number can be any number, but the last two digits must be the ones shown in Figure 2-25.

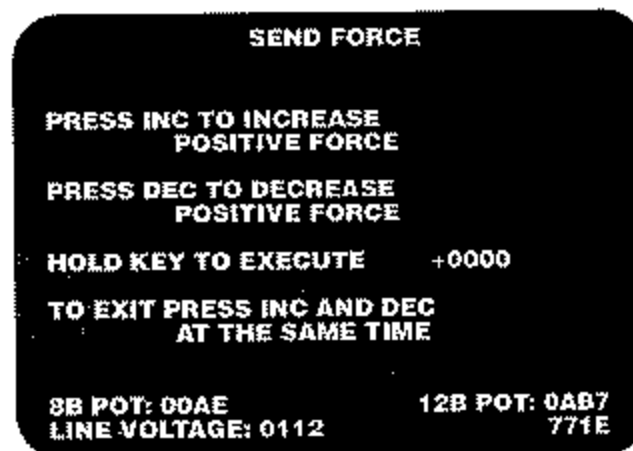


Figure 2-22 Send Force Screen

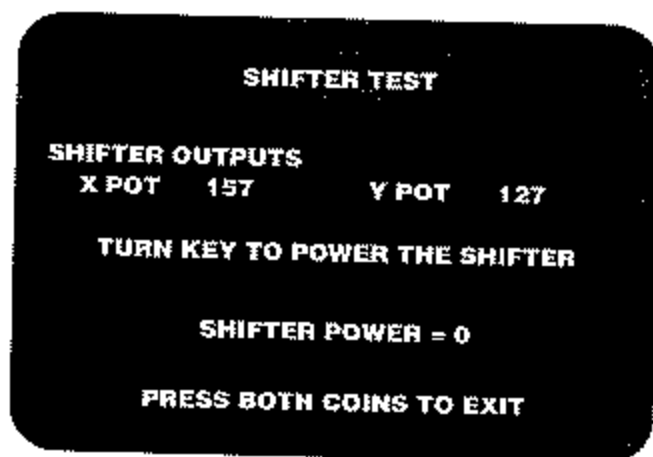


Figure 2-23 Shifter Screen

## Main Board ZRAM Test

This test checks the non-volatile RAM where the simulator statistics and control set-up values are kept. Check the ZRAMs if you think the statistics are incorrect. Also use this test if the control settings are changing even though you have recently set them with the *Set Controls* screens.

If the simulator loses power or is reset while it is in this test, then the statistics and the control settings will be lost. If this happens, use the *Set Controls* item from the main menu to reset the controls. The statistics cannot be restored.

## ADSP Board Tests

Use this item if the ADSP PC board fails the micropro-

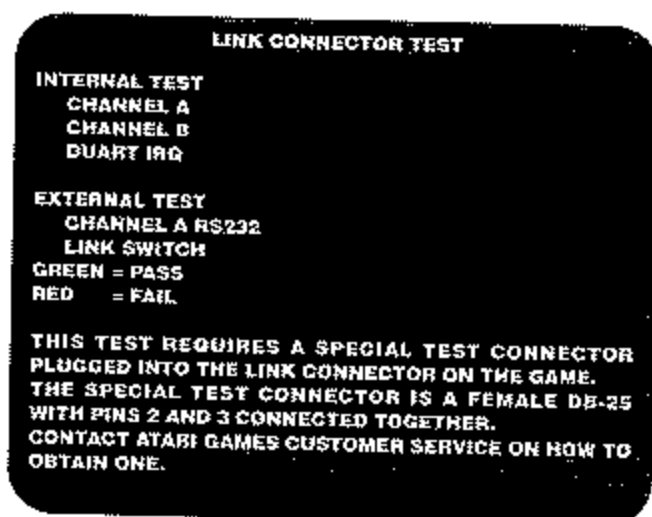


Figure 2-24 Link Connector Test Screen

cessor and board tests performed in the automated self-test.

When you select *ADSP Board Tests* from the Test menu the screen in Figure 2-26 appears. The items on the screen are explained below.

- *Exit* returns to the Test menu.
- *ADSP RAM Tested by 68010* tests the memory on the ADSP PC board. The 68010 on the main PCB test the ADSP program memory, the ADSP data memory, and both ADSP output buffers. The memory tests are the standard, complete tests but are run at the 68010's bus speed, which is slower than that of the 2100.
- *ADSP Program Memory Test .2100.* is a standard, complete memory test run by the 2100 on its own program memory. Since the test program must reside in memory, a bad program RAM may prevent the test from running. However, because the pro-

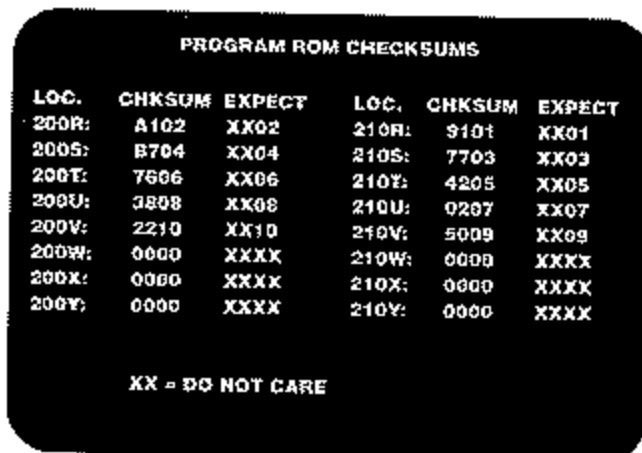


Figure 2-25 ROM Checksums Screen

gram memory is divided into two banks, the test is divided into two parts.

The program to test the upper bank is run from the lower bank; the program to test the lower bank is run from the upper bank. Unfortunately, the 2100 always starts operating from a specific address in the lower bank. Therefore, the lower bank must be operating to the extent that it can execute a JUMP instruction to the upper bank.

These tests operate solely with program memory; they do not require that any data memory be operational.

- *ADSP Data Memory Test* is a standard, complete test run by the 2100. It operates solely with program memory and does not require that any data memory be functional.

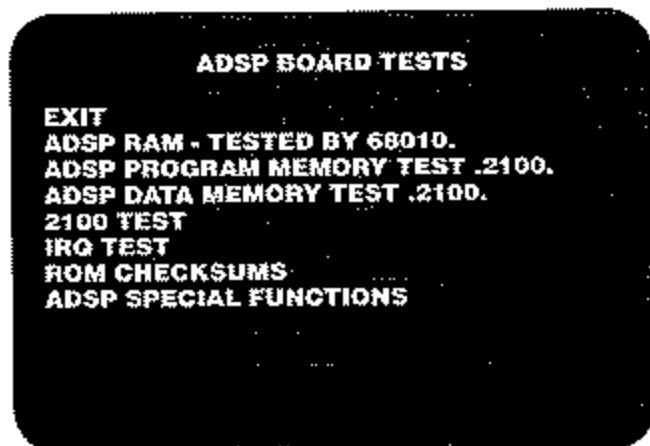


Figure 2-26 ADSP Board Tests Screen

- *2100 Test* checks the response of the 2100 integrated circuit on the ADSP PC board by copying data from one location to another using a 2100 program.
- *IRQ Test* checks if the ADSP can generate interrupts for the 68010.
- *ROM Checksums* tests the graphic ROMs on the ADSP PC board. When the checksum test is complete a hexadecimal number follows each ROM as shown in Figure 2-27. The first two digits in each hexadecimal number can be any number, but the last two digits must be the ones shown in Figure 2-27. If the last two numbers are different, then the ROM is bad or it is not on the board.
- *ADSP Special Functions* performs hardware diagnosis for use by a repair technician.

## Sound Board

Use these tests if the sound PC board failed the microprocessor and board tests in the automated self-test.

| ADSP ROM CHECKSUMS |        |        |             |      |
|--------------------|--------|--------|-------------|------|
| ADSP #             | CHKSUM | EXPECT | DRIVER ADSP |      |
| 9K:                | 0000   | XXXX   | .2L         | NONE |
| 9/10K:             | 7423   | XX23   | .0L         | 16X  |
| 10K:               | A924   | XX24   | .1L         | 10L  |
| 9H:                | 0000   | XXXX   | .2H         | NONE |
| 9/10H:             | 9021   | XX21   | .0H         | 10H  |
| 10H:               | 0022   | XX22   | .1H         | 10J  |

XX = DO NOT CARE

Figure 2-27 ADSP ROM Checksums Tests Screen

If the sound PC board failed the test, select this item from the Test menu and Figure 2-28 appears. Many of the tests require an oscilloscope and schematics. These are indicated on the list below. The tests are explained below.

- *Exit* returns to the Test menu.
- *Play Sounds* takes you to the *Requesting Sound Screen*. Follow the instructions on the screen to hear the simulator sounds.
- *Self-Test* checks the sound program ROM and RAM, COMRAM, and 320 RAM.
- *SD ROM Checksums* tests the ROMs holding the waveform data. The screen appears in Figure 2-29. It shows the ROM location, a hexadecimal number, and the results of the test for each ROM. The result will be one of the following:

*NL*—Nothing is loaded in that socket. No action is required.

*BAD*—The ROM is bad.

*OK*—The ROM is OK.

*PROG DEV*—The ROM is a program development ROM.

*320 Sweep*—Runs a program in the sound PC board 32010 to generate a sine wave sweep from 20 Hz to 9 KHz (requires oscilloscope).

*320 Tune*—Runs a program in the sound PC board 32010 to play a tune.

*Program ROM*—Tests the sound PC board program ROMs with the sound PC board 68000 and reports the results on the screen.

*Program RAM*—Tests the sound PC board program RAMs with the sound PC board 68000 and reports the results on the screen.

*COMRAM*—Tests the sound PC board communications RAM with the sound PC board 32010 and re-

| SOUND BOARD TESTS |              |
|-------------------|--------------|
| EXIT              | LED TEST     |
| SELF-TEST         | DAC RAMP     |
| SD ROM CHECKSUMS  | DAC 250 HZ   |
| PLAY SOUNDS       | SA COUNTER   |
| 320 SWEEP         | SB LATCH     |
| 320 TUNE          | 320 TONE     |
| PROGRAM ROM       | 320 IRQ      |
| PROGRAM RAM       | 320 DAC RAMP |
| COMRAM            | 320 DAC ONES |
| 320 RAM           | 320 SBLOCK   |

SOUND SOFTWARE VERSION 3.0

Figure 2-28 Sound Board Tests Screen

ports the results on the screen.

**320 RAM**—Tests the sound PC board 32010 program RAM with the sound PC board 68000 and reports the results on the screen.

**LED Test**—Flashes the Test LED with the sound PC board 68000.

**DAC Ramp**—Writes to every DAC value with the sound PC board 68000. The sawtooth frequency is about 60 Hz (requires oscilloscope).

**DAC 250 Hz**—Writes to every fourth DAC value with the sound PC board 68000. The sawtooth frequency is about 250 Hz (requires oscilloscope).

**SA Counter**—Creates an oscilloscope loop for the sound address counter (requires oscilloscope).

**SB Latch**—Creates an oscilloscope loop for the sound block latch (requires oscilloscope).

**320 Tone**—Plays a sine wave tone created by the 32010 (requires oscilloscope).

**320 IRQ**—Generates interrupts with the 32010 which the 68000 on the sound board recognizes (requires oscilloscope).

**320 DAC Ramp**—The sound PC board 32010 ramps the DAC (requires oscilloscope).

**320 DAC Ones**—The sound PC board 32010 writes walking ones through the DAC latch (requires oscilloscope).

**320 SBLOCK**—The sound PC board 32010 writes increasing addresses to the Sound Block Latch (requires oscilloscope).

- extra RAM for storing player races
  - extra non-volatile RAM for remembering the Championship Lap
  - extra ROM
  - two separate ASIC systems for increasing the performance level of the simulator
- The DSK Board Test screen is shown in Figure 2-30.
- **DSK ROM Checksums** tests the ROMs on the DSK board.
  - **DSK ZRAM** test the additional non-volatile RAM used for storing the race of the Challenge Lap champion.

The remaining tests on the menu (ASIC 61xxxx, ASIC 65xxxx, and DSK Special Functions) are used by the factory for quality testing.

## LEDs on the Main PCB

The LEDs (light emitting diodes) on the main PCB show you the status of various signals on the main PCB. Using the LEDs, you can check signals from various circuits going to the 68010 processor. The state of the signals is indicated by the LEDs which flash or stay lit.

Figure 2-31 shows the location of the LEDs on the main PCB. Table 2-6 shows the possible status of the LEDs, with an explanation of what they indicate.

## DSK Board Tests

The DSK board is part of the Driver Speed Kit and turbocharges the simulator. The DSK board features:

## DIP Switches

If you try to enter the self-test, but nothing appears on the screen, use the DIP switch tests. Use the informa-

| SOUND BOARD TESTS        |      |          |
|--------------------------|------|----------|
| SOUND WAVE ROM CHECKSUMS |      |          |
| 65A                      | FFFF | NL       |
| 55A                      | 1FC2 | OK       |
| 45A                      | FB00 | OK       |
| 30A                      | 4313 | OK       |
| 20A                      | 5190 | OK       |
| 5A                       | 1F88 | OK       |
| 65C                      | FD29 | NL       |
| 55C                      | DFC0 | OK       |
| 45C                      | 313B | OK       |
| 30C                      | 6A35 | OK       |
| 20C                      | FFFF | NL       |
| 5C                       | 76CB | PROG DEV |

Figure 2-29 Sound Board Sound Wave ROM Checksums

| DSK BOARD TESTS                           |  |
|---|--|
| EXIT                                      |  |
| DSK ROM CHECKSUMS                         |  |
| DSK ZRAM                                  |  |
| ASIC 61 VITAL SIGNS                       |  |
| ASIC 61 IRQS                              |  |
| ASIC 61 INTERNAL RAM                      |  |
| ASIC 61 EXTERNAL RAM: SIMPLE TEST 60 SECS |  |
| ASIC 65 VITAL SIGNS                       |  |
| ASIC 65 CHECKSUM                          |  |
| ASIC 65 INTERNAL RAM                      |  |
| DSK SPECIAL FUNCTIONS                     |  |

Figure 2-30 DSK Board Test Screen

tion from these diagnostic tests to help you find the problem.

Before you begin with these following tests, be sure that the problem is in the simulator hardware, not in the video display. If you have a completely dark screen, check the following:

- Do you have power to the video display?
- Are the video display's filaments lit?
- Do you have high voltage to the video display?

If the answer to any of these questions is **no**, then you have a problem in the video display. Check the video display service manual included with your simulator for suggested procedure.

If you are sure that the problem is not with the video display, then **try** the DIP switch diagnostics shown in Table 2-8. These tests isolate various ICs and systems for troubleshooting. The results of the tests are indicated by the main PC board LEDs or on the video display screen.

### Setting the DIP Switches for the Tests

1. Put a jumper across the DIAGN test points, shown in Figure 2-30.
2. Select the diagnostic test you want to use with the DIP switch settings.
3. Turn on the self-test switch.
4. Put a jumper momentarily across the RESET test points, shown in Figure 2-30.

### Changing to Another DIP Switch Test

1. Change the DIP switch settings.
2. Put a jumper momentarily across the RESET test points, shown in Figure 2-30.

### Ending the DIP Switch Testing

1. Take the jumper off the DIAGN test points.
2. Put a jumper momentarily across the RESET test points.

The DIP switch settings are **on** in the top position when the main PCB is in the simulator.

**Table 2-6 LED Status**

| LED       | Indicates                                       | Status   |
|-----------|---|--|
| Run LED   | State of 68010 HALT signal.                     | <i>On</i> when 68010 is running.<br><i>Off</i> when 68010 processor is not running.<br><i>Flashing at 2 Hz</i> if the 68010 cannot run. (The watch-dog and clock must be running.)<br>(The Run LED is <i>on</i> in game mode.)                               |
| DTACK LED | State of 68010 DTACK (data acknowledge) signal. | <i>On</i> when the 68010 processor is running and the timing circuit is probably operating.<br><i>Flashes at 2 Hz</i> when the 68010 processor cannot run. (The watchdog and processor clock must be running.)<br>(The DTACK LED is <i>on</i> in game mode.) |
| Clock LED | State of the 68010 processor clock signal.      | <i>On</i> when the game board is on.<br><i>Off</i> if the processor clock signal is stuck high or low.   |
| IRQS LED  | State of all 68010 interrupts.                  | <i>On</i> in the game mode.<br><i>Off</i> in hardware diagnostic mode and the early part of self-test.<br><i>Off</i> if no interrupts are occurring or any interrupt signal is stuck low.  |



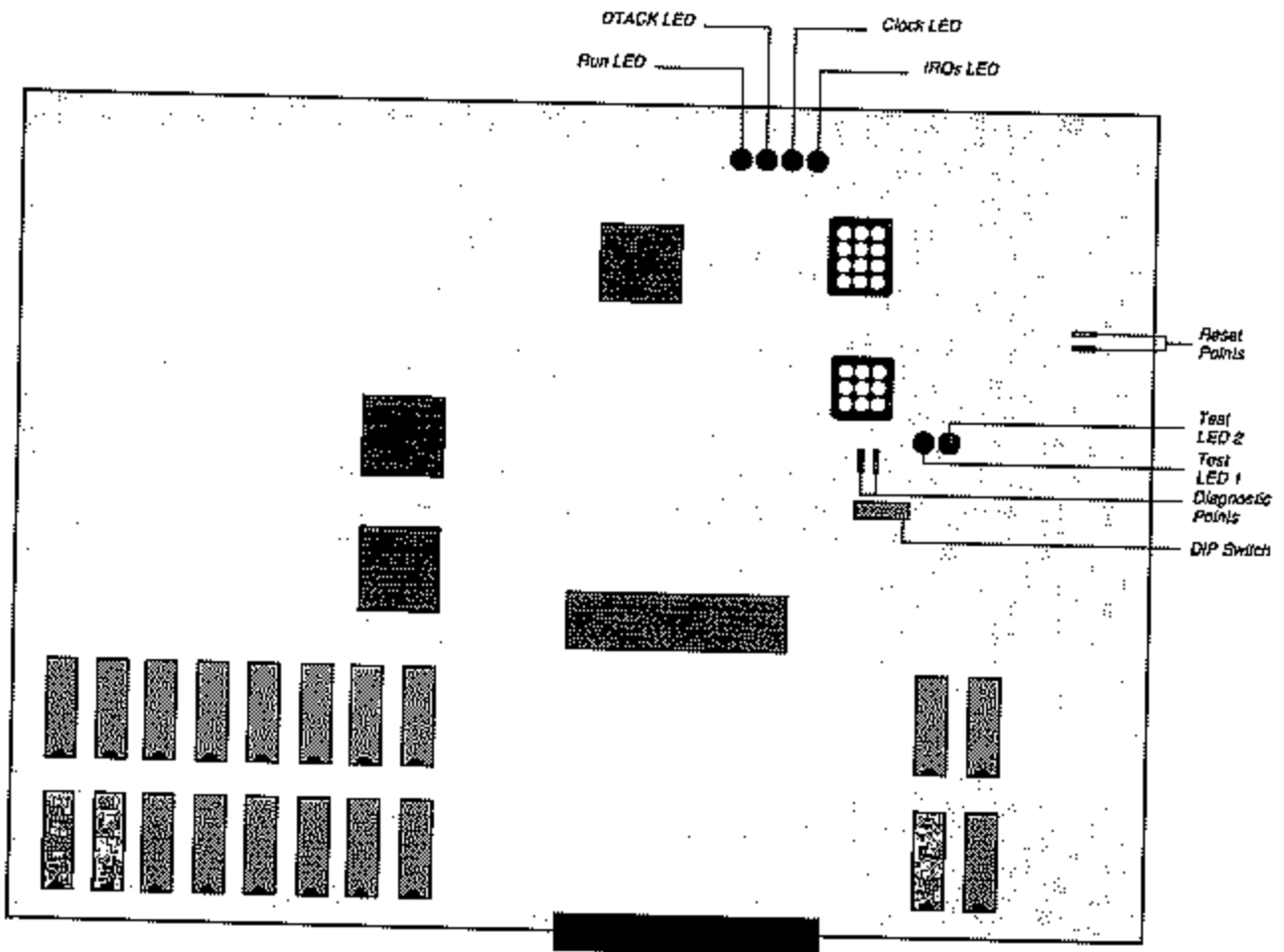
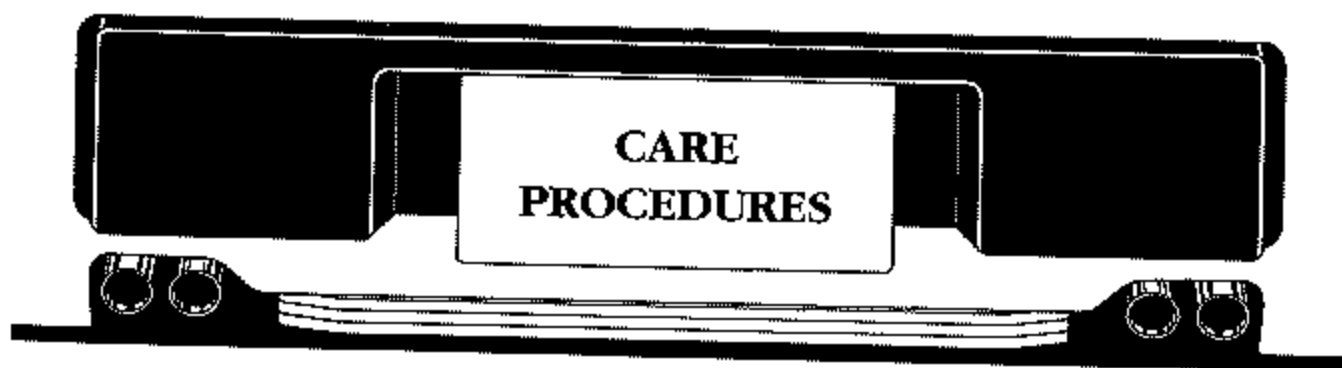


Figure 2-31 DIP Switch and LED Locations on the Main PCB

Table 2-7 Using the DIP Switches

| Type of Test  | Purpose and Results  | DIP Switch Settings |   |   |   |   |   |   |   |
|---|--|---------------------|---|---|---|---|---|---|---|
|   |  | 1                   | 2 | 3 | 4 | 5 | 6 | 7 | 8 |
| <b>Watchdog, Test Program ROMs, Test Menu RAMs, and LED Tests</b> |  |                     |   |   |   |   |   |   |   |
| Uncleared Watchdog  | Puts the 68010 in a loop. Does <i>not</i> clear the watchdog counter. The program RAM does not need to work. If the watchdog is working, the run LED, DTACK LED, and IRQs LED flash at 2 Hz and the clock LED is on.           | X                   | X | 0 | 0 | 0 | 0 | 0 | 0 |
| Cleared Watchdog  | Puts the 68010 in a loop. Clears the watchdog counter. The program RAM does not need to work. If the watchdog is working, the run LED, clock LED, DTACK LED and IRQs LED are on.   | X                   | X | 0 | 0 | 0 | 0 | 0 | 1 |
| Test LEDs   | Tests the test LEDs. The program RAM does not need to work. If the test LEDs are working, they flash at 2 Hz.  | X                   | X | 0 | 0 | 0 | 0 | 1 | 1 |
| Test Program ROM 0  | Tests ROM 0 H and 0 L, which hold the test program. (This test takes about 5 seconds.) LED 1 and LED 2 flash together if both ROMs are good. If ROM 0 L is bad, LED 1 does not flash. If ROM 0 H is bad, LED 2 does not flash. | X                   | X | 0 | 0 | 0 | 1 | 1 | 1 |
| Test Menu RAM 0   | Tests RAM 0 H and 0 L, which run the test menu. (This test takes about 5 seconds.) LED 1 and LED 2 flash together if both RAMs are good. If RAM 0 L is bad, LED 1 does not flash. If RAM 0 H is bad, LED 2 does not flash.     | X                   | X | 0 | 0 | 1 | 1 | 1 | 1 |
| <b>GSP Tests</b>  |  |                     |   |   |   |   |   |   |   |
| GSP Communications  | Tests if the 68010 can communicate with the GSP, which produces the video. If the GSP responds, the LEDs flash together. If the GSP does <i>not</i> respond, LED 1 and 2 flash alternately.                                    | X                   | X | 0 | 1 | 1 | 1 | 1 | 1 |
| Red Screen  | Produces a red screen from the color RAM, regardless of GSP VRAM input. Use this to check the red video outputs.   | X                   | X | 0 | 1 | 1 | 1 | 1 | 0 |
| Green Screen  | Produces a green screen from the color RAM, regardless of GSP VRAM input. Use this to check the green video outputs.   | X                   | X | 0 | 1 | 1 | 1 | 0 | 0 |
| Blue Screen   | Produces a blue screen from the color RAM, regardless of GSP VRAM input. Use this to check the blue video outputs.   | X                   | X | 0 | 1 | 1 | 0 | 0 | 0 |
| GSP Memory Fill   | Does a very slow GSP memory fill so you can test the pixel scanner.  | X                   | X | 0 | 1 | 0 | 0 | 0 | 0 |
| GSP VRAM Verify   | Performs the GSP VRAM verify test. (This test is also in the self-test.)   | X                   | X | 1 | 0 | 0 | 0 | 0 | 0 |
| <b>ROM and RAM Tests</b>  |  |                     |   |   |   |   |   |   |   |
| ROM Test Loop   | The results are displayed on the screen.   | X                   | X | 1 | 0 | 0 | 0 | 0 | 1 |
| RAM Test Loop   | The results are displayed on the screen.   | X                   | X | 1 | 0 | 0 | 0 | 1 | 1 |
| <b>MSP Tests</b>  |  |                     |   |   |   |   |   |   |   |
| MSP Interface   | Tests the MSP interface. Results are displayed on the screen.  | X                   | X | 1 | 0 | 0 | 1 | 1 | 1 |
| MSP Auto Increment  | Tests the MSP auto-increment. Results are displayed on the screen.   | X                   | X | 1 | 0 | 1 | 1 | 1 | 1 |
| MSP Interrupts  | Tests the MSP interrupts (IRQs). Results are displayed on the screen.  | X                   | X | 1 | 1 | 1 | 1 | 1 | 1 |
| MSP DRAM Verify   | Performs the MSP DRAM verify test. (This test is also in the self-test.) The results are displayed on the screen.  | X                   | X | 1 | 1 | 1 | 1 | 1 | 0 |
| <b>Bus Error Test</b>   |  |                     |   |   |   |   |   |   |   |
| BERR  | The DTACK timer times out and generates a bus error (BERR) signal. The results are displayed on the screen.  | X                   | X | 1 | 1 | 1 | 1 | 0 | 0 |
| 1=On; 0=Off; X=Doesn't Matter.                                    |  |                     |   |   |   |   |   |   |   |

# Maintenance & Troubleshooting



This chapter includes maintenance, repair, and troubleshooting information for your Race Drivin™ simulator.

The chapter is organized with the general information first and the specific information about parts and controls last. The general information includes a schedule for simulator maintenance and inspection, a table with general troubleshooting information, and a table of the voltage levels and test points on the PCBs. The specific information is arranged by the part or control with maintenance procedures, repair procedures, troubleshooting tables, and troubleshooting flowcharts for each part.

In the simulator, the hardware and software are closely related. If you are having problems with a mechanical assembly, always keep in mind that your electrical connections may not be good or you may have an electronic problem. To determine what kind of the problem you have, use the self-test screens as recommended in the troubleshooting tables and flowcharts.

If after using these tests and screens, you decide to repair a part, the procedures for removal, disassembly, and repair are provided in this chapter. If a part is mentioned, but not illustrated, refer to Chapter 4, *Illustrated Parts Lists*, for information. ☺ ☺ ☺ ☺ ☺

## Maintaining and Inspecting

Preventive maintenance includes inspecting, cleaning, lubricating, and tightening hardware. Perform the preventive maintenance regularly so you can keep the simulator in top condition, avoid problems, and maximize your earnings. Preventive maintenance tasks and intervals are shown in Table 3-1.

### Maintaining Your Simulator

For the best performance from your Race Drivin' simulator, you should check and maintain your simulator according to the times shown in Table 3-1. How to perform these tasks is explained in the section about that control in this chapter. You may want to perform these tasks more often if the simulator is heavily used.

Table 3-2 is the first of ten troubleshooting tables in this chapter. Use this table if *all* of your controls are acting erratically or not responding. If only one control is not working, go to the section about that control and read the troubleshooting information there.

Table 3-3 shows the correct voltage levels to various PC boards and the test points for those voltage levels. Low voltages to PC boards may cause problems with the controls, with the video display, or in driving.

## Dashboard

### Removing the Dashboard

Remove the dashboard to service the steering assembly. See Figure 3-1.

#### WARNING

*The dashboard weighs about 40 pounds. Be careful when you remove it.*

1. Turn off the power and unplug the game.
2. Take off the under-dash cover over the brake and clutch pedals. It is held in place by two Phillips-head screws. See Figure 4-1 for an illustration.
3. Remove the four nuts on either side of the dashboard and take out the carriage bolts.

#### NOTE

*Do not remove the four tamperproof screws around the steering wheel unless you are replacing the steering assembly. Even then, remove the bolts only after the dashboard is out of the simulator.*

**Table 3-1 Maintenance and Inspection Items**

| Part                          | When to Check  | What to Check and Maintain  |
|-------------------------------|----------------|---|
| Coin Mechanism                | Every 6 months | Clean.  |
| Brake and Clutch Pedals       | Every 3 months | Oil all bearings. Check the switch and switch actuator distance.  |
| Video Display Face and Shield | Every 6 weeks  | Take off the video display shield and clean the shield and the face of the video display. (Carbon particles emitted by the steering motor collect on the shield and video display, obscuring the view.) |
| Game Exterior                 | Every 3 months | Make sure the glides are down. The casters may be damaged if the glides are not used.   |
| Gas Pedal                     | Every 6 months | Be sure the rubber stop behind the clutch on the firewall is still on.  |
| Interior Components           | Every 3 months | Spray the pivot pin, spring cable, and pulley with dry Teflon spray.  |
| Key Switch                    | Every 3 months | Clean.  |
| Shifter                       | Every 3 months | Lightly oil the spring and shaft.   |
| Steering Wheel                | Every 3 months | Check the shifter boot for damage. Make sure the foam in the boot is in place.  |
|                               |                | Grease the threads. Check the rubber stops and tighten the screws that hold the stops on.   |
|                               |                | Make sure the potentiometer shaft has a very light coat of grease.  |
|                               |                | Make sure the stop assembly on the motor shaft is tight on the shaft.   |
|                               |                | To prevent injuries, replace the steering wheel if the rim or spoke padding is worn out.  |

**Table 3-2 Troubleshooting All Controls**

| Problem   | Solution  |
|---|---|
| All controls do not respond or respond erratically. | <ol style="list-style-type: none"> <li>1. Go through the <i>Set Controls</i> screens in the self-test.</li> <li>2. Have you recently installed a new PCB or new controls? If so, go through the <i>Set Controls</i> screens in the self-test.</li> <li>3. Check the ZRAMs in the self-test for errors.</li> <li>4. The simulator may have lost power during a ZRAM test. Go through the <i>Set Controls</i> screen in the self-test.</li> </ol> |

4. Unlock the bottom service door to reach the nuts on the carriage bolts underneath the dashboard at the rear. Take off the nuts and washers.
5. Also from the rear, disconnect the four connectors from the dashboard harness to the simulator harness.
6. Remove the Phillips-head screws on the front and under the dashboard.
7. The dashboard is now supported by the top lip and the side panels. Sit in the simulator seat and pull the dashboard forward and out of the simulator onto your lap.

## Installing the Dashboard

1. Sit in the seat with the dashboard in your lap. Pull the seat towards the video display. Lift up the dashboard and slide it in on the side panels.
2. Feed the dashboard harnesses through the front panel cutouts. Push the dashboard into place.
3. Hold the dashboard in place and put the carriage bolts in on either side. Put the washers and the nuts on the bolts.
4. Go around to the back of the simulator and connect the steering assembly and the switch harnesses to the simulator harness. Then install the two carriage bolts with washers and nuts under the

**Table 3-3 Voltage Inputs and Test Points on the Simulator PCBs**

| PCB   | Voltage     | Test Points    | Source and Purpose   |
|-------|-------------|----------------|--|
| Main  | +5±0.1 VDC  | +5V2           | +5 V Switching Power Supply  |
| Main  | +15±0.6 VDC | +15V1          | Regulated and supplied by the APU PCB. Used by the 12-bit A/D converter and runs the +12 VDC regulator.      |
| Main  | -22 VDC     | -22V1          | Unregulated and supplied by the APU PCB. Runs the -5V regulator.   |
| Main  | +12±0.5 VDC | +C127          | Regulated and comes from the +15 VDC supply. Used by the 12-bit A/D converter and the sound PCB.             |
| Main  | -5±0.2 VDC  | -C125          | Regulated and comes from the unregulated -22 VDC supply. Used by the 12-bit A/D converter and the sound PCB. |
| ADSP  | +5 VDC      | +5V1 or +5V2   | Regulated and supplied from the Main PCB through the interface cable.  |
| Sound | +5 VDC      | +5V2           | Supplied and regulated by the main PCB through the sound power cable. Used by the logic circuitry.           |
| Sound | +12 VDC     | 105B Pin 4     | Supplied and regulated by the main PCB through the sound power cable. Used by the analog circuitry.          |
| Sound | -5 VDC      | 5R Pin 4       | Supplied and regulated by the main PCB through the sound power cable. Used by the analog circuitry.          |
| Sound | +5 VDC      | +5V2           | Supplied and regulated by the main PCB through the interface cable.  |
| Sound | -15 VDC     | 105B Pin 11    | Supplied by the APU PCB through the main PCB. Used by the 12-bit D/A converter on the sound PCB.             |
| APU   | +14VDC      | See schematics | Used by the coin counters and the audio amps on the APU PCB.   |
| APU   | -14VDC      | See schematics | Used by audio amps on the APU PCB.   |
| APU   | -22VDC      | See schematics | Used by the main PCB.  |
| APU   | +15VDC      | See schematics | Regulated; used by the main PCB.   |

dashboard at the rear.

5. Install the two tamperproof screws and washers. Finally install the Phillips-head screws under the dashboard.
6. Install the under-dash cover above the brake and clutch pedals. Screw in the two Phillips-head screws that hold it in place.
7. Close and lock the service door.

## Steering Assembly

If you have problems with the steering assembly, check the troubleshooting suggestions in Table 3-4. Always perform the *Set Controls* screens in the self-test first.

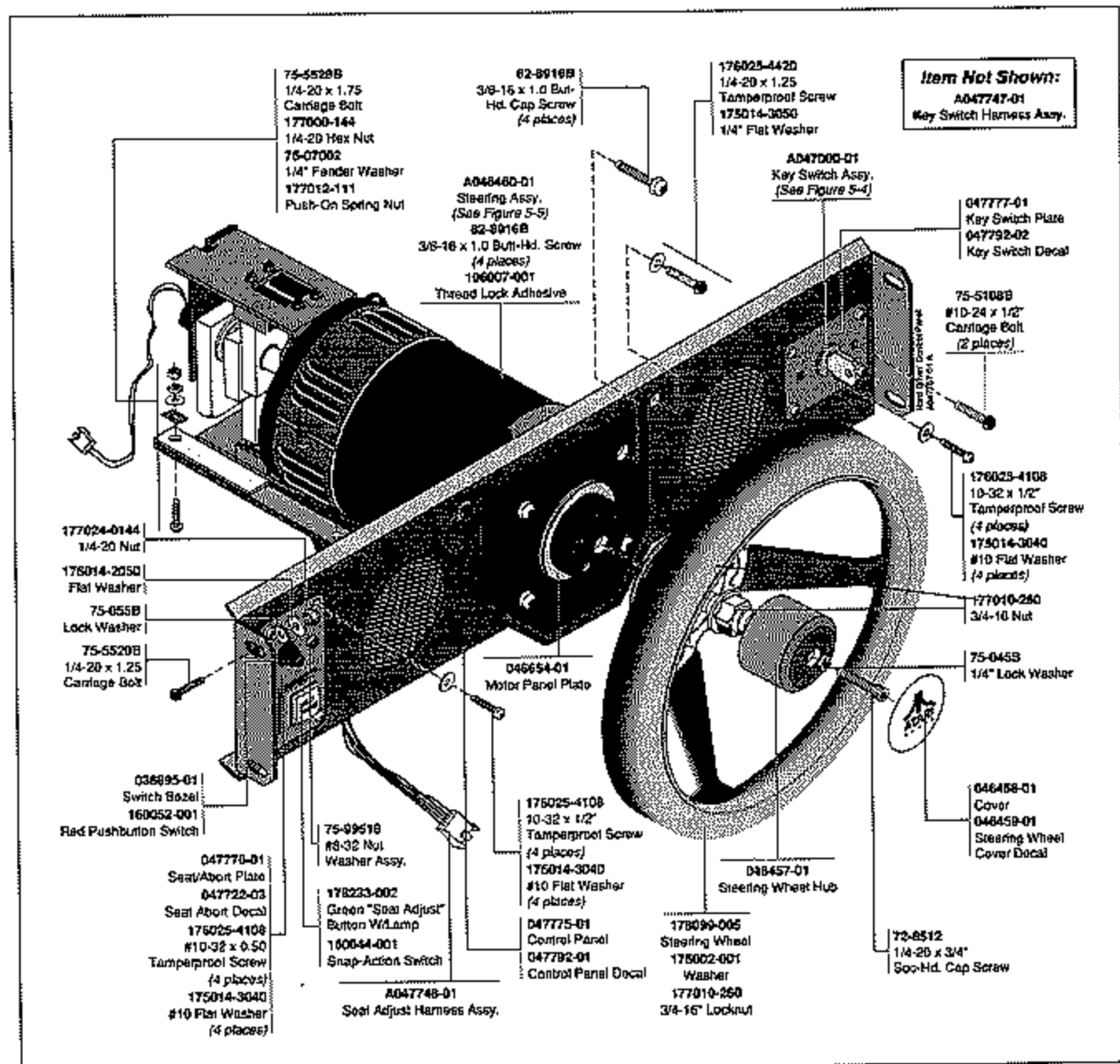


Figure 3-1 Removing and Installing the Dashboard

## Greasing the Steering Assembly

Grease the steering assembly threads and stop regularly according to the maintenance schedule and if turning the steering wheel becomes difficult (and the problem is not the steering motor).

1. Take out the dashboard. See the procedure in the section *Removing the Dashboard*.
2. Grease the large threads on the stop assembly. See Figure 3-5.
3. Put the dashboard back in. See the procedure in the section *Installing the Dashboard*.

## Replacing the Steering Assembly Potentiometer

Replace the potentiometer after you have followed the flowchart in Figure 3-2, 3-3, or 3-4 and you are sure the problem is the potentiometer.

1. Take out the dashboard. Follow the instructions in the section *Removing the Dashboard*.
2. Loosen the set screw that holds the potentiometer shaft in place. See Figure 3-5. Remove the nut that

holds the potentiometer in the potentiometer bracket. Take out the potentiometer. If the small spring that holds the potentiometer bracket on the stop bracket is broken, replace it.

3. Solder the wiring harness to the new potentiometer. Connect the red wire nearest the shaft, the clear wire in the middle, and black wire at the end.

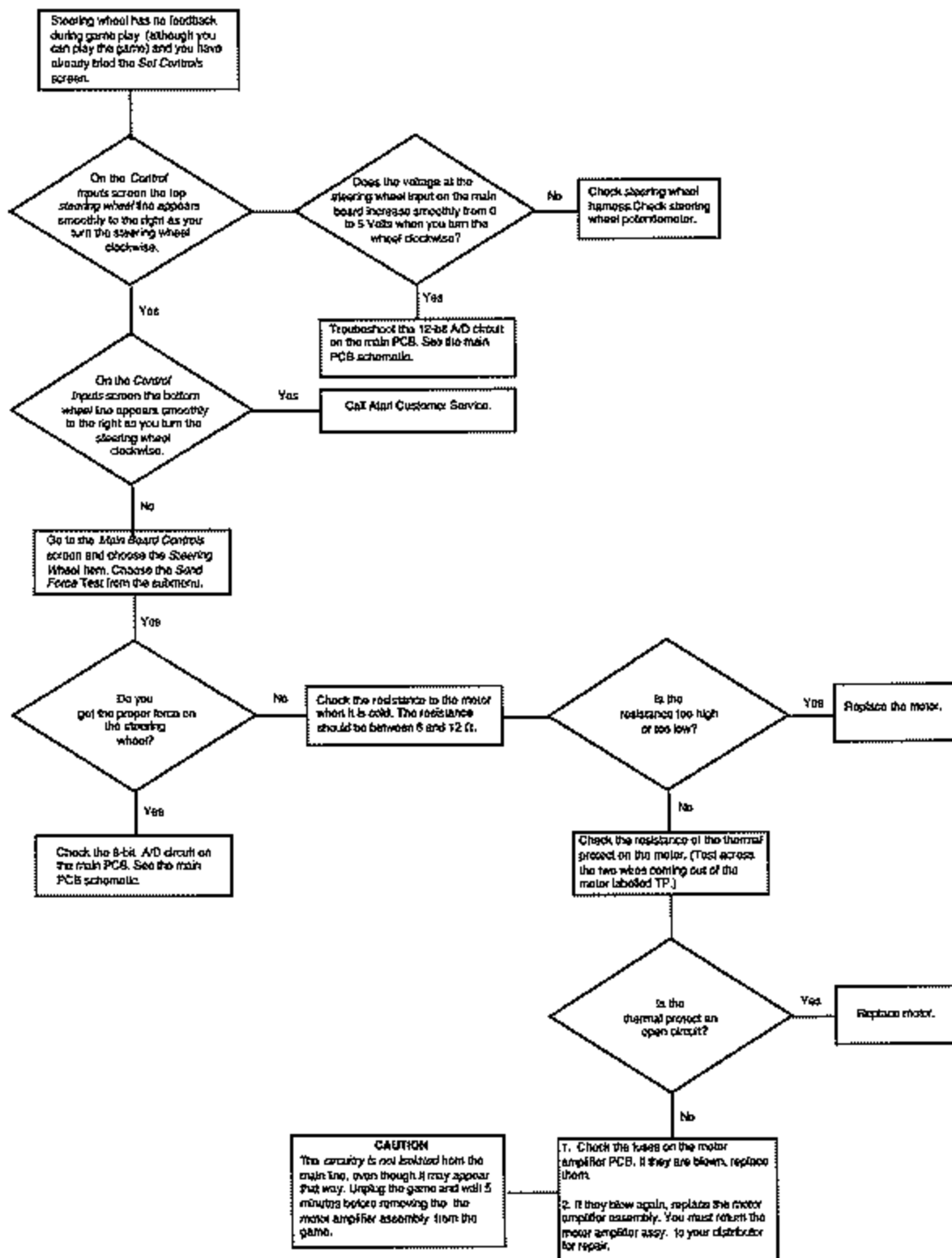
### CAUTION

*Carefully follow the instructions for installing the new potentiometer. If you do not, you might destroy the potentiometer.*

4. Set up the potentiometer. Hold the new potentiometer with its shaft facing you and turn the shaft as far as it can go in the counterclockwise direction. Then turn the shaft back about 15 degrees.
5. Face the stop bracket on the end of the motor; then turn the motor shaft as far as it will go in the clockwise direction.
6. Apply one drop of light oil to the potentiometer shaft before you install it in the bracket.
7. Install the potentiometer into the potentiometer bracket with the flat of the shaft facing down and

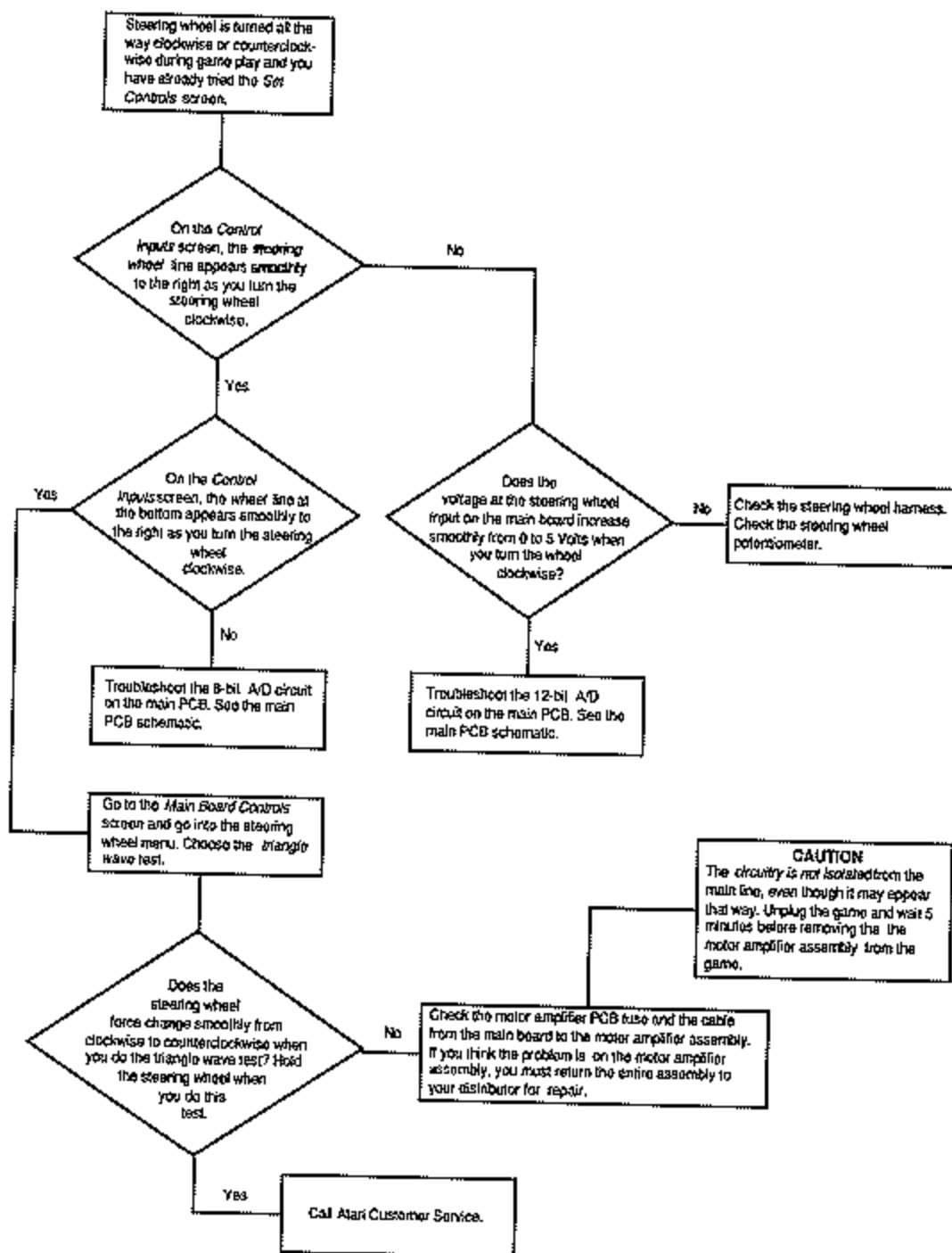
Table 3-4 Troubleshooting the Steering Assembly

| Problem  | Solution  |
|--|---|
| Steering wheel does not respond or responds erratically.                                   | <ol style="list-style-type: none"> <li>1. Go through the <i>Set Controls</i> screens in the self-test.</li> <li>2. Check the <i>Control Inputs</i> screen to see if the potentiometer input to the board is functioning correctly. The steering wheel and wheel lines, which both indicate steering wheel position, should smoothly appear and disappear as you turn the wheel.</li> <li>3. Check the connections to the potentiometer and to the motor.</li> <li>4. Check voltage level to main PCB. See Table 3-3.</li> </ol> |
| Steering wheel is difficult to turn.   | <p>Grease the threads.</p> <p>Check the steering assembly for broken parts.</p> <p>Check the motor bearings by turning the shaft and seeing if it spins freely.</p>   |
| Steering has no feedback.  | <ol style="list-style-type: none"> <li>1. Try the <i>Set Controls</i> screens in the self-test.</li> <li>2. See Figure 3-2 to determine the cause of the problem.</li> </ol>  |
| Steering is very jerky.  | <p>Some jerkiness is OK.</p> <ol style="list-style-type: none"> <li>1. Try the <i>Set Controls</i> screens in the self-test.</li> <li>2. If you think the steering is very jerky, see Figure 3-4 for more information.</li> </ol>   |
| Steering wheel is turned all the way to one side or the other during play and stays there. | <ol style="list-style-type: none"> <li>1. Try the <i>Set Controls</i> screens in the self-test.</li> <li>2. See Figure 3-3 for more information.</li> </ol>   |
| Steering wheel can spin more than three times around. Force on the steering wheel changes. | <p>Replace the stop assembly and the potentiometer.</p> <p>The force on the steering wheel should be lighter when the seat is closer to the dashboard and harder when the seat is further away. This so children, who sit closer to the dashboard to drive, will be able to turn the steering wheel easily.</p>   |

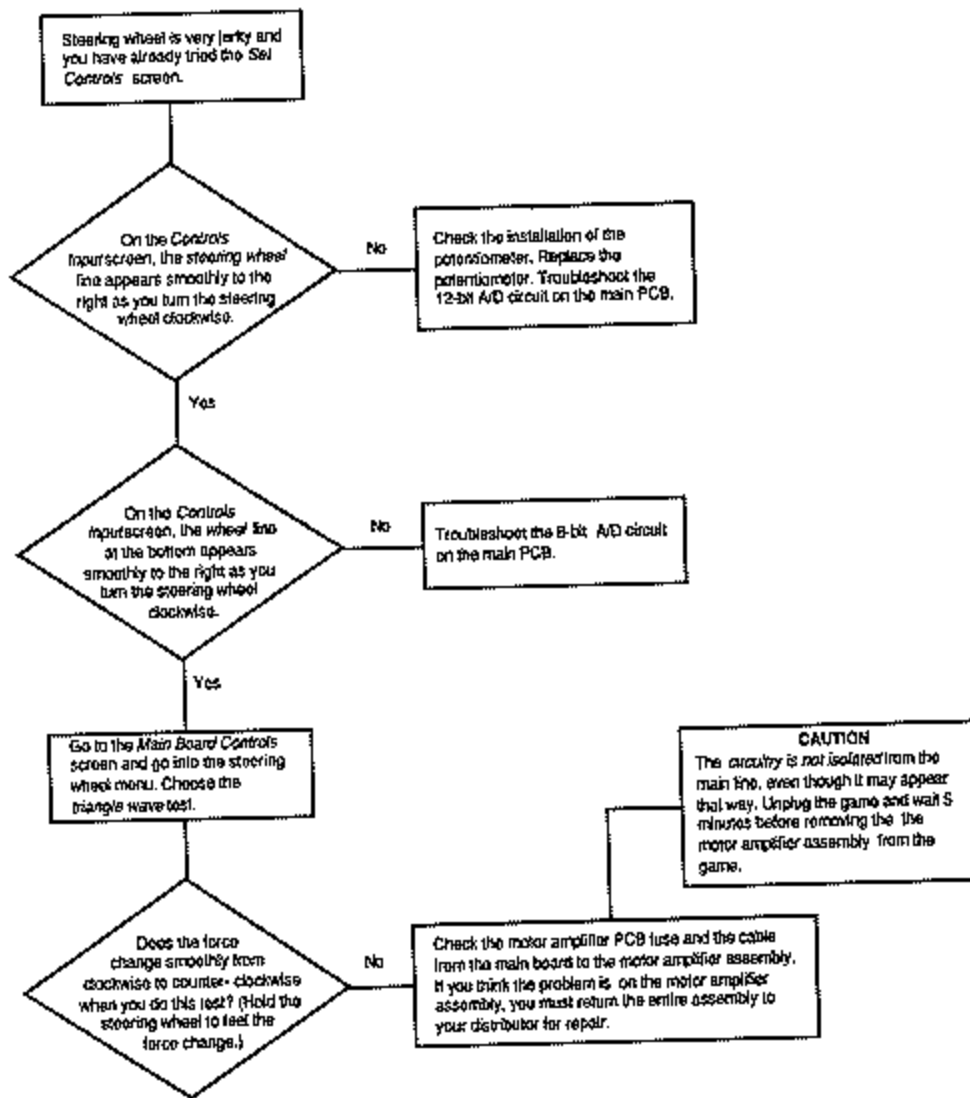


**Figure 3-2 Steering Wheel Has No Feedback and You Have Tried the Set Controls Screens**





**Figure 3-3 Steering Wheel is Turned All the Way to One Side and You Have Tried the Set Controls Screens**



**Figure 3-4 Steering Wheel Is Jerky and You Have Tried the Set Controls Screens**

the tab in the keyhole.

8. Put the lock washer and nut on the potentiometer shaft and tighten the nut. Do not turn the potentiometer shaft from the position at which you set it.
9. Insert the potentiometer shaft into the motor shaft; tighten the socket-head screw.
10. Check the alignment of the potentiometer and the motor by carefully turning the motor shaft as far as it will go clockwise and counterclockwise. Check that the potentiometer shaft turns as far as the mo-

tor shaft turns in both directions. If the potentiometer shaft stops turning before the motor shaft stops turning, then do steps 4 through 9 again.

11. Put the dashboard back in the simulator, following the instructions in the section *Installing the Dashboard*.
12. Go to the *Set Controls* screens in the self-test and re-initialize all the controls.

**NOTE**

*You must go through the Set Controls screens in the self-test because you replaced the potentiometer. If you do not do this, the simulator will not work correctly.*

## Replacing the Steering Assembly Motor

Replace the steering assembly motor if you have followed the flowchart in Figure 3-2 and you are sure that the motor is the problem. Another reason to replace the motor is if the steering wheel is difficult to turn and the problem is not lubrication or the mechanical parts.

Before you replace the motor, check the harness connections to make sure they are good.

### Removing the Steering Assembly Motor

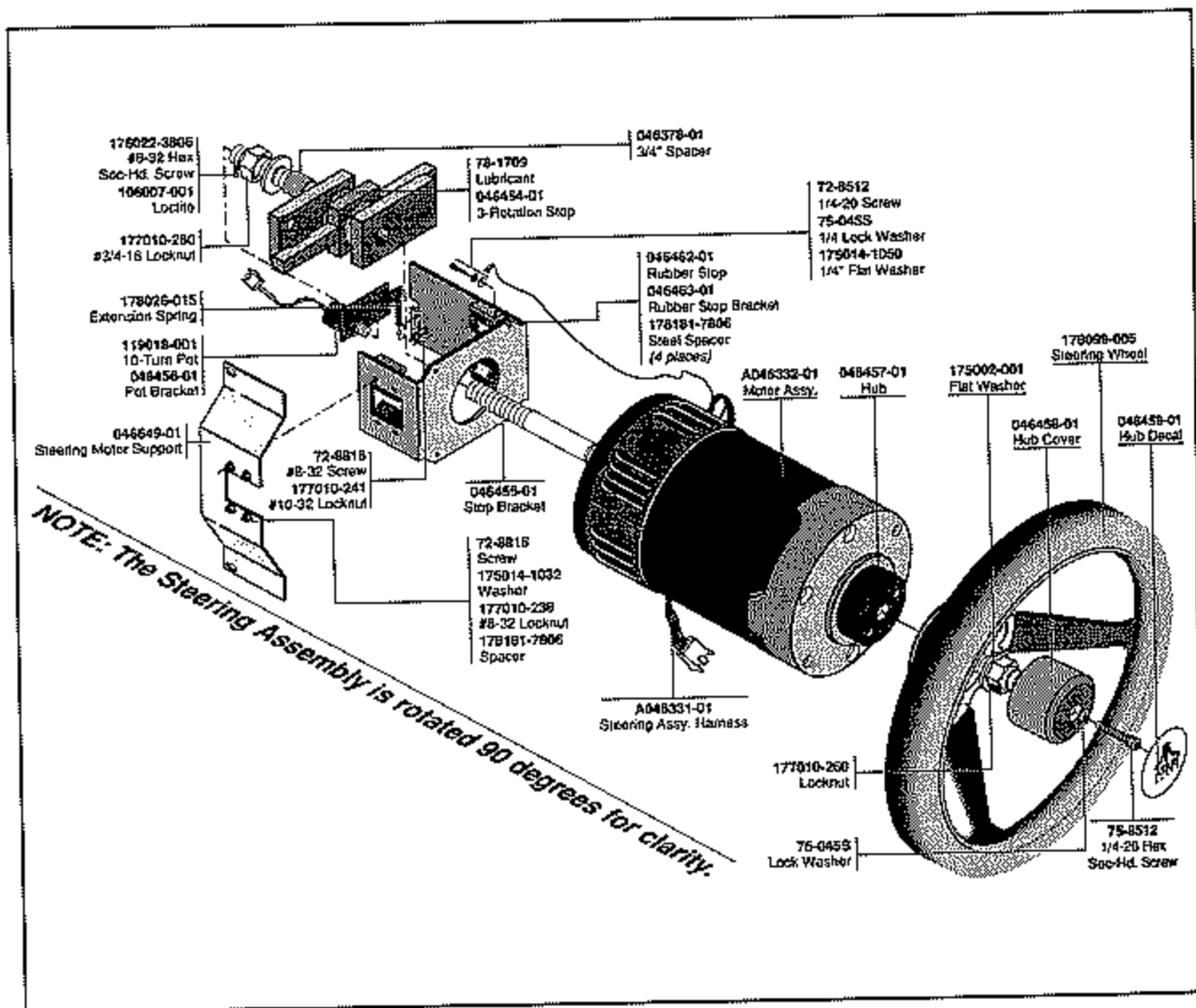
1. Take out the dashboard. Follow the instructions in the section *Removing the Dashboard*.
2. Carefully peel off the Atari Games decal on the hub of the steering wheel. The steering assembly is shown in Figure 3-5.
3. Unscrew the socket-head screw under the decal. Remove the screw, the washer and the hub cover.
4. Remove the large nut under the hub cover with a 1 1/16-inch socket. The nut is torqued to 50 foot-pounds.
5. Take off the washer and the steering wheel.
6. At the other end of the steering assembly, remove the potentiometer from the end of the motor shaft by loosening the small screw at the end of the shaft. Take off the potentiometer and the potentiometer bracket.
7. Remove the nut at the end of the motor shaft which holds the stops on the shaft. This nut requires a 1 1/16-inch socket and is torqued to 50 foot-pounds. Remove the washer.
8. Remove the four tamperproof screws that hold the steering assembly on the dashboard. These are torqued to 340 inch-pounds. Take the steering assembly and the motor support plate off the dashboard.
9. Use a puller to loosen the stop assembly on the tapered shaft. You must remove the stop assembly at the same time as you remove the stop bracket.
10. Remove the four socket-head screws and washers that hold the stop bracket on the motor. Pull the stop bracket and the stop assembly off the motor shaft.

### Checking the Steering Assembly Motor

11. Do the following tasks before you re-assemble the parts on the new motor:
  - a. Tighten the socket-head screws that hold the rubber stops in place.
  - b. Generously grease the threads.
  - c. Check the spring that holds the potentiometer shaft on the stop bracket. If it is broken, replace it.
  - d. Check the round stops on the corners of the large rectangular stops on the stop assembly. Make sure the round stops are not cracked or broken.

### Replacing the Steering Assembly Motor

12. Put the stop assembly into the holes in sides of the stop bracket. Push the stop bracket and the stop assembly on the shaft of the new motor. (When you tighten the nut on the end of the shaft the stop assembly will be correctly seated.) Put the key slot on the stop assembly over the key on the shaft.
13. Screw the four socket-head screws and washers into the stop bracket and motor. Install the ground wire under the wide washer at the top left screw.
14. Replace the nut and the washer at the end of the motor shaft. Torque the nut to 50 foot-pounds.
15. Set up the potentiometer. Hold the new potentiometer with its shaft facing you and turn the shaft as far as it can go in the counterclockwise direction. Then turn the shaft back about 15 degrees clockwise.
16. Face the stop bracket on the end of the motor; turn the motor shaft as far as it will go in the clockwise direction.
17. Apply one drop of light oil to the potentiometer shaft before you install it in the bracket.
18. Install the potentiometer into the potentiometer bracket with the flat of the shaft facing down and with the tab in the keyhole.
19. Put the lock washer and nut on the potentiometer shaft and tighten the nut. Do not turn the potentiometer shaft from the position at which you set it.
20. Insert the potentiometer shaft into the motor shaft; tighten the socket-head screw.
21. Check the alignment of the potentiometer and the motor by carefully turning the motor shaft as far as it will go clockwise and counterclockwise. Check that the potentiometer shaft turns as far as the motor shaft turns in both directions. If the potentiometer stops turning before the shaft stops turning, then do steps 15 through 20 again.



**Figure 3-5 Maintaining the Steering Wheel**

22. Using the four tamperproof screws, install the steering assembly and the motor support plate on the dashboard. Put Loctite on the carriage bolts before you put the nuts on them. Tighten the nuts to  $340 \pm 10$  inch-pounds so the steering assembly will not twist on the dashboard.
23. Install the steering wheel on the steering hub. Put the hole in the steering wheel over the alignment stud on the hub. (See Figure 3-5.)
24. Put on the washer and the large nut. Torque the nut to 50 foot-pounds.
25. Install the hub cover, split-lock washer, and the socket-head screw. Put Loctite on the screw before installing it. Tighten it to 95 inch-pounds.
26. Replace the Atari Games decal on the hub.
27. Put the dashboard back in the simulator, following the instructions in the section *Installing the Dashboard*.
28. Go to the *Set Controls* screens in the self-test and re-initialize all the controls.

## Replacing the Steering Assembly Stop

It is unlikely that the steering assembly stop will have to be replaced. If it does, follow the instructions in *Replacing the Steering Assembly Motor* for assembly and disassembly. You also must replace the potentiometer on the steering assembly.

## Key Switch Assembly

Table 3-5 lists what can go wrong with the key switch assembly.

### Oiling the Key Switch Assembly

Oil the key switch bezel ring and shaft regularly, when turning the key switch becomes difficult, or when the key squeaks.

1. Turn off the power. Remove the key switch plate.
2. Take the key switch assembly out of the dashboard by removing the two carriage bolts and locknuts.
3. Lightly oil the shaft and spring of the key switch. See Figure 3-6. Check that the spring is not broken. If it is, then replace the spring following the procedure under *Replacing the Spring in the Key Switch Assembly*.
4. Replace the key switch in the dashboard and install the key switch plate.

### Replacing the Spring in the Key Switch Assembly

If nothing happens when the key turns, and there is no resistance to turning, you may need to replace the spring.

1. Turn off the power. Remove the key switch plate.
2. Take the key switch assembly out of the switch plate by removing the two carriage bolts and locknuts.
3. Remove the retaining ring from the back of the key switch case. See Figure 3-6.
4. Loosen the socket-head screw on the brass actuator with a 5/32-inch Allen-head wrench.
5. Remove the other retaining ring inside the case. Pull out the key. Take out the brass actuator, the old spring, and the nylon washer.
6. Put lithium grease (Atari Games part no. 107029-

- 001) inside the collar. Wipe off the excess grease.
7. Put one end of the spring into the hole in the side of the case.
8. Push the shaft back into the case far enough to mount the spring on the shaft. You may have to cut the legs of the spring to the correct length so that they do not interfere with the operation of the switch assembly.
9. Put the brass actuator into the case with the actuator pin facing the key and opposite the switch. Catch the free end of the spring under the pin. Push the actuator and the nylon washer onto the shaft.
10. Push the shaft through the case and install the two retaining rings.
11. Adjust the actuator on the shaft until it is parallel to the roller on the switch.
12. When the actuator is against the case opposite the switch, the key should be vertical. If the key is not vertical, turn it until it is. Tighten the screw on the actuator.
13. Use a piece of a manila folder or any other flat material about .015 inches thick to adjust the switch distance. Hold the actuator against the switch so that the switch clicks once when you turn the key. If the switch is too close, it will click twice instead of once when you turn the key. Tighten the screws on the switch when the position is correct.  
Release the actuator. Check the setting. When you turn the actuator against the switch, the switch should click, but not be pressed all the way to the switch body.
14. Put the key switch assembly back on the dashboard and replace the key switch plate.

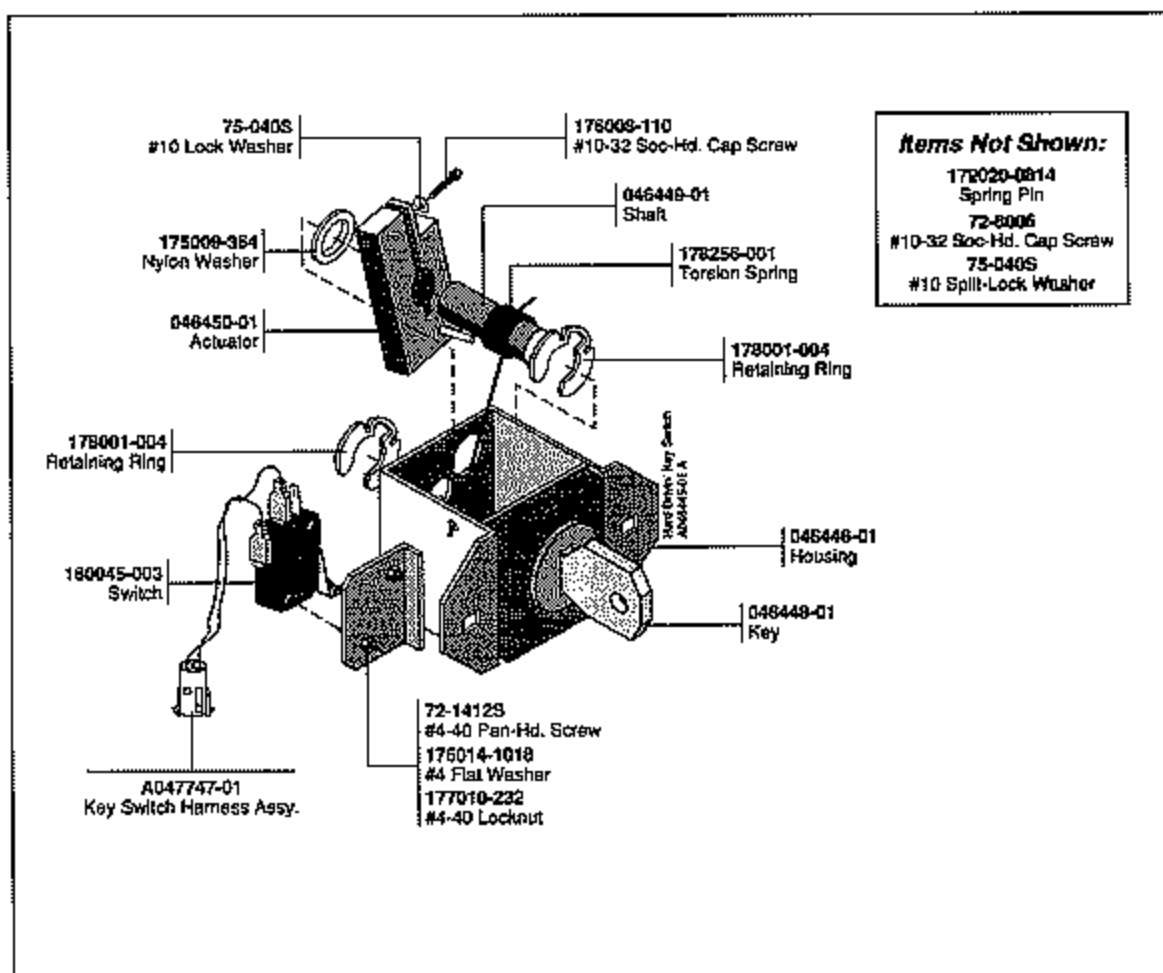
### Tightening the Screw in the Key Switch Actuator

If nothing happens when the key turns, and it turns more than 90°, you may need to tighten the screw on the actuator.

1. Turn off the power. Remove the key switch plate.

**Table 3-5 Troubleshooting the Key Switch**

| Problem  | Solution   |
|--|--|
| Key does not return when turned and has no resistance. | The actuator screw may be loose or the spring may need to be replaced.                       |
| Key turns more than 90°.                               | The actuator is loose; tighten the screw on the actuator.                                    |
| Key turns, but nothing happens.                        | Check the snap-action switch, switch connectors, actuator location, and harness connections. |
| Key squeaks when turned.                               | Oil the collar and shaft.  |



**Figure 3-6 Maintaining the Key Switch Assembly**

- Adjust the actuator on the shaft until it is parallel to the roller on the switch. See Figure 3-6.
- When the actuator is against the case opposite the switch, the key should be vertical. If the key is not vertical, turn it until it is. Tighten the screw on the actuator.
- Now hold the actuator against the switch and move the switch so that when you turn the key, the switch clicks once. If the switch is too close, it will click twice instead of once when you turn the key. Tighten the screws on the switch when the position is correct.
- Replace the key switch plate.

## Replacing the Switch on the Key Switch Assembly

Replace the switch if the key turns but nothing happens and the problem is not the spring, the actuator, or the connections. The key switch assembly is shown

in Figure 3-6.

- Turn off the power. Remove the key switch plate.
- Take the key switch out of the dashboard by removing the two carriage bolts and locknuts.
- Remove the two Phillips-head screws that hold the snap-action switch on the key switch assembly. Take off the switch. Take the harness off the switch.
- Install the switch on the assembly, but do not tighten the screws. The roller on the switch should face the brass switch actuator.
- Loosen the screw on the brass actuator. Adjust the actuator on the shaft until it is parallel to the roller on the switch.
- When the actuator is against the case opposite the switch, the key should be vertical. If the key is not vertical, turn it until it is. Tighten the screw on the actuator.
- Now hold the actuator against the switch and move

the switch so that when you turn the key, the switch clicks once. If the switch is too close, it will click twice instead of once when you turn the key. Tighten the screws on the switch when the position is correct.

- Put the harness on the new switch. Connect the black wire to the C (or COM) terminal, and the white/black wire to the NO terminal.
- Put the key switch assembly back into the dashboard and install the key switch plate.

## Clutch Pedal

The clutch is part of the clutch and brake pedal assembly. If you have trouble with the clutch, first go through the *Set Controls* screens. If that does not cure the problem, see Table 3-6, *Troubleshooting the Clutch Pedal*.

If you must repair the clutch, but you cannot do so immediately, you can disable the clutch circuit. All drivers must use the automatic transmission if you do this. Do this only as a temporary measure. Repair the clutch as soon as possible.

To disable the circuit, go to the *Disable Broken Controls* screen in the self-test and choose *broken* for the clutch.

## Maintaining the Clutch and Brake Pedals

Take the pedals out of the simulator to maintain them. Regular maintenance includes oiling the pedals, which should be done with the pedals out of the simulator, since you cannot reach all the points and you may get oil on the PC boards below the pedals when they are in the game.

- Turn off the power and unplug the game.
- Take off the under-dash cover above the pedal assembly. Use a Phillips screwdriver to remove the four screws that hold the cover on.

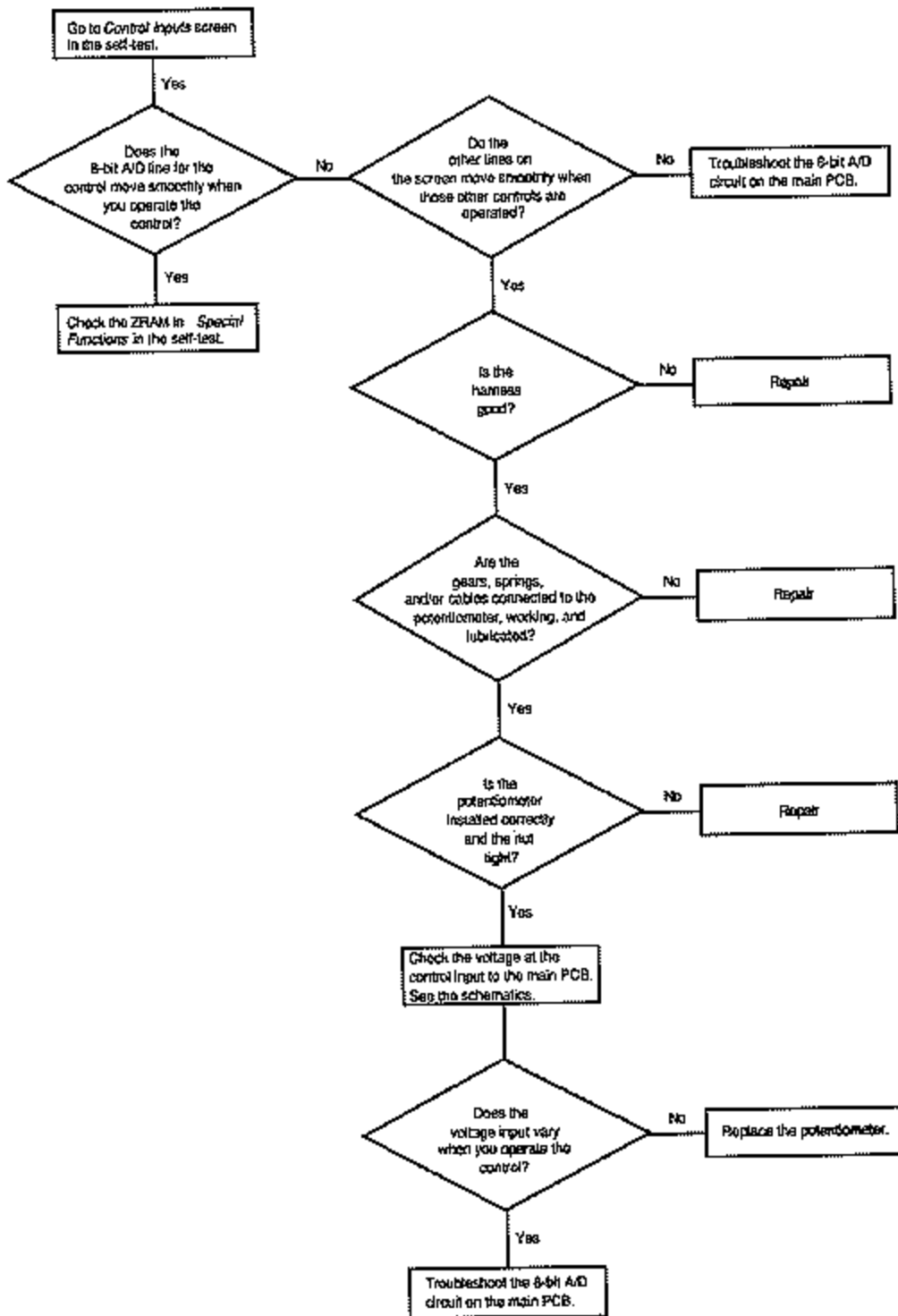
- Unlock the bottom service door. Unplug the harness connector to the pedal.
- The back of the pedal assembly is above the main PC board. Remove the four nuts and fender washers holding the pedal assembly to the cabinet. After you remove the nuts, the pedals will hang in the same position.
- Go to the front. Twist and pull the pedal assembly counterclockwise to avoid the bottom of the dashboard.
- Put light oil on the eight bearing points shown in Figure 3-8.
- Before you install the pedal assembly, check the following.
  - Can you push the brake pedal 1/4 to 1/2 inch before you feel resistance? If you feel resistance before this point, first check the bearings to see if they are moving. If the bearings are moving, adjust the nut on the brake spring return shaft so that the pedal has at least 1/4 inch of free play.
  - Does the pedal return to its resting location? If not, check if the return spring is broken or the bearings are binding.
  - Does the brake pedal move at least 1/4 inch before the switch clicks? If not, adjust the clamp on the white plastic actuator until you have 1/4 inch of play in the pedal. Make sure the switch clicks before you feel resistance on the pedal.
- Put the pedal assembly back in the simulator. Install the fender washers and the locknuts. Connect the simulator harness.

## Replacing the Clutch Potentiometer

Do not replace the potentiometer until you have performed the *Set Controls* screens. Check to see if that solves the problem. If not, follow the flowchart in Figure 3-7 to make sure that the potentiometer is the

Table 3-6 Troubleshooting the Clutch Pedal

| Problem                                    | Solution   |
|--|--|
| Clutch does not work or works erratically. | <ol style="list-style-type: none"> <li>Perform the <i>Set Controls</i> screens in the self-test.</li> <li>Follow the flowchart in Figure 3-7 to find the cause of the problem.</li> <li>Check connections.</li> <li>Check voltage levels to the main PCB. See Table 3-3.</li> <li>If you had disabled the clutch circuit, but the clutch is now repaired, choose <i>working</i> on the <i>Disable Broken Controls</i> screen.</li> </ol> |
| Does not return.                           | <ol style="list-style-type: none"> <li>Check the bearings.</li> <li>The springs may be broken or weak.</li> </ol>  |



**Figure 3-7 Clutch, Seat, or Gas Pedal Is Not Working or Working Erratically and You Have Tried the Set Controls Screens**



problem.

1. Turn off the power and unplug the game.
2. Take off the cover above the pedal assembly under the dashboard. Use a Phillips screwdriver to remove the four screws that hold the cover on.
3. Unlock the bottom rear service door. The back of the pedal assembly is above the main PCB. Disconnect the simulator harness from the assembly. Remove the washers and nuts holding the pedal assembly to the cabinet. After you remove the nuts, the pedals will hang in the same position.
4. Go to the front of the simulator. Twist and pull pedal assembly counterclockwise to avoid the bottom of the dashboard.
5. See Figure 3-8 for an illustration of the pedals. The clutch potentiometer is mounted on the brake side of the pedal assembly. Loosen the locknut on the potentiometer with a 1/2-inch flat wrench.
6. Loosen the screw on the small gear with a 3/32-inch Allen wrench.
7. Take off the gear, nut, washer, and potentiometer. Remove the wires on the potentiometer.
8. With the shaft of the new potentiometer facing you and the terminals pointing up, solder the black wire on the left terminal, the yellow on the middle, and the red to the right terminal.
9. Put on the new potentiometer. Insert the key into the key hole in the assembly frame. The potentiometer terminals must point up. Put the nut and washer on, but do not tighten the nut all the way.
10. Put the gear on the potentiometer shaft. The screw must be vertical and over the flat part of the shaft. Make sure that the gear meshes with and is directly over the gear below. Tighten the screw. Tighten the nut on the potentiometer.
11. Carefully press the clutch pedal and make sure that the potentiometer shaft turns until the pedal reaches its stop. If it does not, re-install the potentiometer, following steps 9 and 10.
12. Put the pedal assembly back in the simulator. Install the fender washers and the locknuts. Re-connect the simulator harness.
13. Now switch on the self-test and go through the *Set Controls* screens.

#### NOTE

*You must enter the self-test and go through the Set Controls screens because you repaired the pedal assembly. Otherwise the simulator will not work correctly.*


## Replacing the Clutch Springs

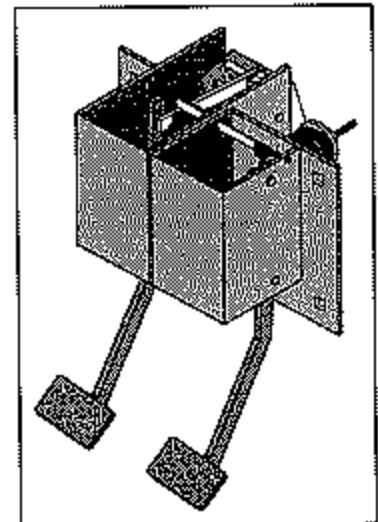
Replace the clutch springs if the clutch does not return to position and the springs are weak or broken. See Figure 3-8 for an illustration of the pedals.

1. Turn off the power and unplug the game.
2. Take off the under-dash cover above the pedal assembly. Use a Phillips screwdriver to remove the four screws that hold the cover on the cabinet.
3. Open the bottom rear service door. The back of the pedal assembly is above the main PC board. Disconnect the simulator harness from the assembly. Remove the washers and nuts holding the pedal assembly to the cabinet. After you remove the nuts, the pedals will hang in the same position.
4. Go to the front of the simulator. Twist and pull the pedal assembly counterclockwise to avoid the bottom of the dashboard.
5. Remove the metal stop bracket on the assembly with the rubber bumper pads attached to it. Remove the two socket-head screws, one on either side, which hold the bracket to the frame. (You do not need to remove the rubber bumper pads.) Pull the stop bracket out the assembly.
6. Take off the locking tabs on the end of the spring shafts. Use an Allen wrench to remove the socket-head screws on the tabs.
7. Push the shafts out through the assembly frame and remove the springs.
8. Install the new springs, making sure the ends are hooked over the cut-out areas on the nylon shaft covers.
9. Push the spring shafts back into place and reinstall the locking tabs.
10. Install the stop bracket. Make sure the pedal shafts rest against the rubber bumpers.
11. Put the pedal assembly back in the simulator. Install the fender washers and the locknuts. Re-connect the simulator harness.
12. Now switch on the self-test and go through the *Set Controls* screens.

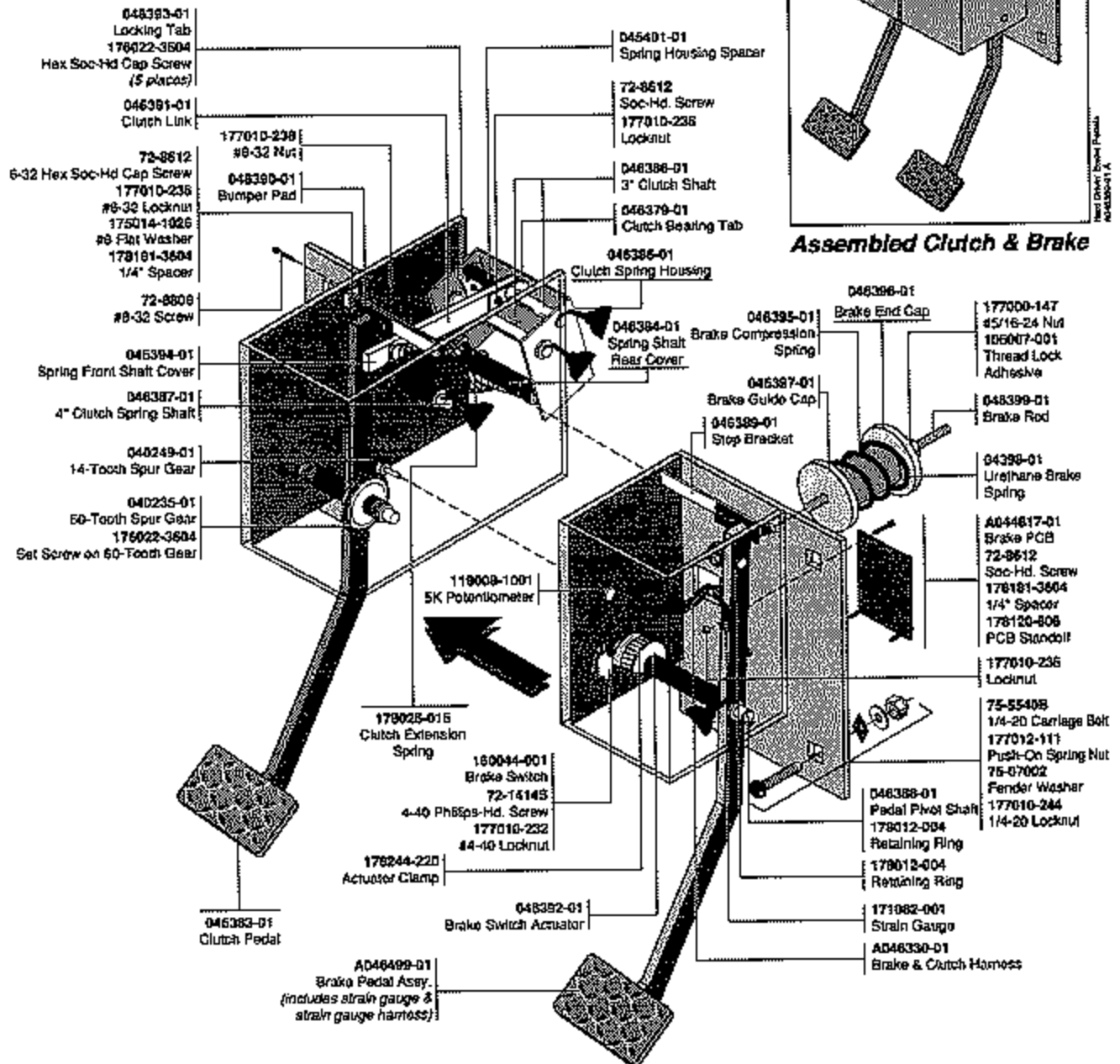
#### NOTE

*Enter the self-test and go through the Set Controls screens when you replace the pedal assembly. Otherwise the simulator will not work correctly.*

 **107013-001**  
Light Oil  
**NOTE:** Lubricate on both ends  
of shafts.



**Assembled Clutch & Brake**



**Figure 3-8 Maintaining the Clutch and Brake Assembly**

## Brake Pedal

The brake is part of the clutch and brake pedal assembly. For maintenance procedures, see *Maintaining the Clutch and Brake Pedals*, above.

### Repairing the Brake

The brake may not work for several reasons. Before you do any repairs, always perform the *Set Controls* screens in the self-test; then try the brake to see if this corrects the problem. If that does not repair the problem see Table 3-7, *Troubleshooting the Brake Pedal* and follow the flowchart in Figure 3-9. The test procedures in the flowchart are explained below.

If you must repair the brake, but you cannot do so immediately, and you want to continue to use your game, you can disable the brake circuit. When you disable the brake, a screen appears before each race which tells drivers that the brake does not work and to slow down, just take their foot off the accelerator.

Disable the brake *only* as a temporary measure. Repair the brake as soon as possible since this is an essential part of the game.

To disable the brake circuit, go to the *Disable Broken Controls* screen in the self-test and choose *braken* for the brake.

### Testing the Switch, Switch Actuator Distance, and Pedal Movement

If you have brake problems, see the flowchart in Fig-

ure 3-9. If necessary, do the following tests to check the switch actuator distance and the switch.

1. Check the actuator adjustment. The pedal should move at least 1/4 inch before the switch clicks. If not, then adjust the clamp on the white plastic actuator until you have 1/4 inch of play in the pedal. The switch must click before you feel resistance on the pedal.
2. Check the resistance on the pedal. It should begin after the switch clicks, but no further than 1/2 inch from the pedal resting place. If you feel resistance before this point, check if the bearings are moving. If the bearings are moving freely, adjust the nut on the brake spring return shaft so that the pedal has at least 1/4 inch of free play, and the switch clicks before the resistance begins.
3. If the pedal does not return to its resting location, check if the return spring is broken or if the bearings are not moving.
4. Check the switch. Disconnect the connector from the Brake PCB and connect an ohmmeter across pins 6 and 7 of the harness connector. If the switch is good, the switch closes when the pedal is *not* pressed, and opens when the pedal is pressed.

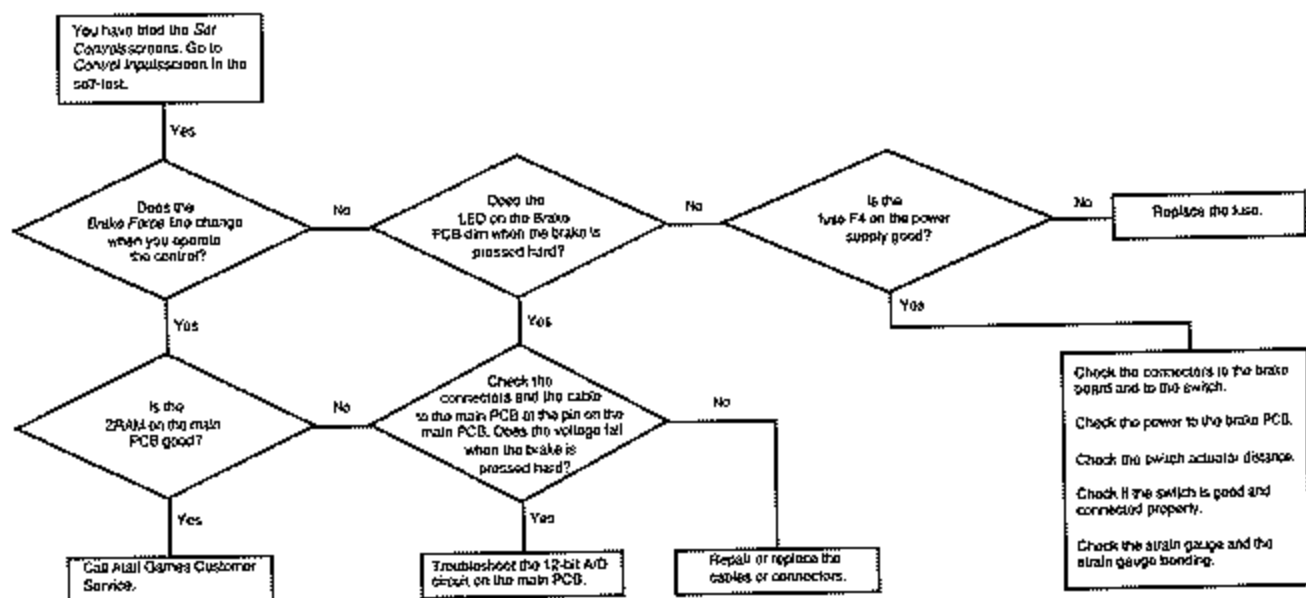
### Testing the Strain Gauge and Strain Gauge Bonding

If you have brake problems, see the flowchart in Figure 3-9. If necessary, do the following tests to check the strain gauge and strain gauge bonding.

1. Remove the connector from the brake PCB in the

**Table 3-7 Troubleshooting the Brake Pedal**

| Problem  | Solution   |
|--|--|
| Brake does not work or is working erratically. | <ol style="list-style-type: none"> <li>1. Go through the <i>Set Controls</i> screens in the self-test.</li> <li>2. Check the P4 fuse on the power supply. (If this fuse is blown, the shifter will not work either.)</li> <li>3. Check the brake force on the 12-bit A/D item in the <i>Control Inputs</i> screen. As you press down on the brake, the line should disappear, in relation to how much force you are putting on the brake.</li> <li>4. Check the harness connections.</li> <li>5. Check the distance adjustment for the switch actuator.</li> <li>6. Check the switch.               <ol style="list-style-type: none"> <li>a. The connections to the brake snap-action switch are incorrect. Harness connections should be on C and NC.</li> <li>b. Check the switch with an ohmmeter as described in <i>Checking and Adjusting the Brake</i>.</li> </ol> </li> <li>7. Check the brake PCB.</li> <li>8. Check the strain gauge by connecting an ohmmeter as described in <i>Testing the Strain Gauge and Strain Gauge Bonding</i>.</li> <li>9. Check voltage level to the main PCB. See Table 3-3.</li> <li>10. If the brake was not working, and you disabled the brake circuit, but now the brake is repaired, go to the <i>Disable Broken Controls</i> screen and choose <i>working</i>.</li> </ol> |



**Figure 3-9 Brake Is Not Working or Working Erratically and You Have Tried the Set Controls Screens**

back of the simulator and put an ohmmeter across pins 1 and 2 of the harness connector. If the ohmmeter does not measure  $350 \Omega \pm 10\%$ , then replace the brake pedal assembly because the strain gauge is bad.

2. If the ohmmeter does measure  $350 \Omega \pm 10\%$ , then check the bonding. Attach a digital volt-ohmmeter to pins 1 and 2 and have someone press hard on the brake. If the resistance does not change as the pressure on the brake pedal changes, then the bonding has failed and you must replace the brake pedal assembly.

## Replacing the Brake Switch

Before you replace the brake switch, do the *Set Controls* screens in the self-test and follow the flowchart in Figure 3-9. Test the switch as explained above in *Testing the Switch, Switch Actuator Distance, and Pedal Movement*. If you are sure that you must replace the switch, do the following procedure.

1. Turn off the power and unplug the game.
2. With the pedal assembly out of the simulator, remove the two nuts that hold the switch against the wall. Take out the screws and the switch.

3. Replace the switch with the terminals pointing towards the top of the pedal assembly. Adjust the actuator position so the brake pedal has at least 1/4 inch of play in it before the switch clicks. Loosen or tighten the clamp on the white plastic actuator to adjust this distance. The switch must click before you feel resistance while pushing the pedal.
4. Connect the wires to the switch. The two wires attach to the C and NC terminals.
5. Put the pedal assembly back in the simulator. Install the fender washers and the locknuts. Reconnect the simulator harness.
6. Now switch on the self-test and go through the *Set Controls* screens.

### NOTE

You must enter the self-test and go through the *Set Controls* screens since you repaired the brake. Otherwise the simulator will not work correctly.

## Replacing the Brake Strain Gauge and Pedal Assembly

Before you replace the brake pedal assembly because you suspect the strain gauge, do the *Set Controls* screens in the self-test and follow the flowchart in Figure 3-9. Test the strain gauge as explained above in *Testing the Strain Gauge and Strain Gauge Bonding*. If you are sure that you must replace the brake pedal assembly, do the following procedure.

### NOTE

*The strain gauge is mounted on the pedal at the factory because special bonding is required. Therefore, you must replace the entire brake pedal assembly if the strain gauge or bonding is bad.*

1. Turn off the power and unplug the game.
2. To replace the brake pedal assembly, take off the under-dash cover above the pedal assembly. Use a Phillips screwdriver to remove the screws that hold the cover on the cabinet.
3. Open the lower rear service door. The back of the pedal assembly is above the main PCB. Disconnect the simulator harness from the assembly. Remove the washers and nuts holding the pedal assembly to the cabinet. After you remove the nuts, the pedals will hang in the same position.
4. Go to the front of the simulator. Twist and pull the pedal assembly counterclockwise to avoid the bottom of the dashboard.
5. On the pedal assembly, disconnect the strain gauge wires from the Brake PCB. See Figure 3-8 for an illustration of the pedals.
6. Remove the metal stop bracket with the rubber bumper pads attached to it. Take out the two screws, one on either side, which hold the bracket to the frame. (You do not need to remove the rubber bumper pads.) Pull the bracket out the assembly.
7. Remove the retaining ring at the top of the brake shaft that holds the shaft and brake springs together.
8. Take off the locking tab on the end of the pedal pivot shaft. Use a 3/16-inch Allen wrench to remove the socket-head screw.
9. Push the pivot shaft towards the clutch. Remove the brake pedal assembly.
10. Put the new brake pedal assembly into position. Push the pivot shaft through the brake shaft and into the case. Install the locking tab and the socket-head screw.

11. Replace the retaining ring at the top of the brake shaft that holds the shaft and the brake springs together.
12. Replace the metal stop bracket. Put in the two screws that hold the bracket to the frame.
13. Re-connect the strain gauge wires to the brake PCB.
14. Check the following to make sure the brake is set up properly:
  - a. Check the actuator adjustment. The pedal should move at least 1/4 inch before the switch clicks. If not, adjust the clamp on the white plastic actuator until you have 1/4 inch of play in the pedal. Make sure the switch clicks before you feel resistance on the pedal.
  - b. Check the resistance on the pedal. It should begin sometime after the switch clicks, but no further than 1/2 inch from the starting point. If you feel resistance before this point, check if the bearings are moving. If the bearings are moving freely, then adjust the nut on the brake spring return shaft so that the pedal has at least 1/4 inch of free play. Check that the switch clicks before resistance begins.
15. Put the pedal assembly back in the simulator. Install the fender washers and the locknuts. Re-connect the simulator harness.
16. Now switch on the self-test and go through the *Set Controls* screens.

### NOTE

*Enter the self-test and go through the Set Controls screens since you replaced the brake pedal assembly. Otherwise the simulator will not work correctly.*

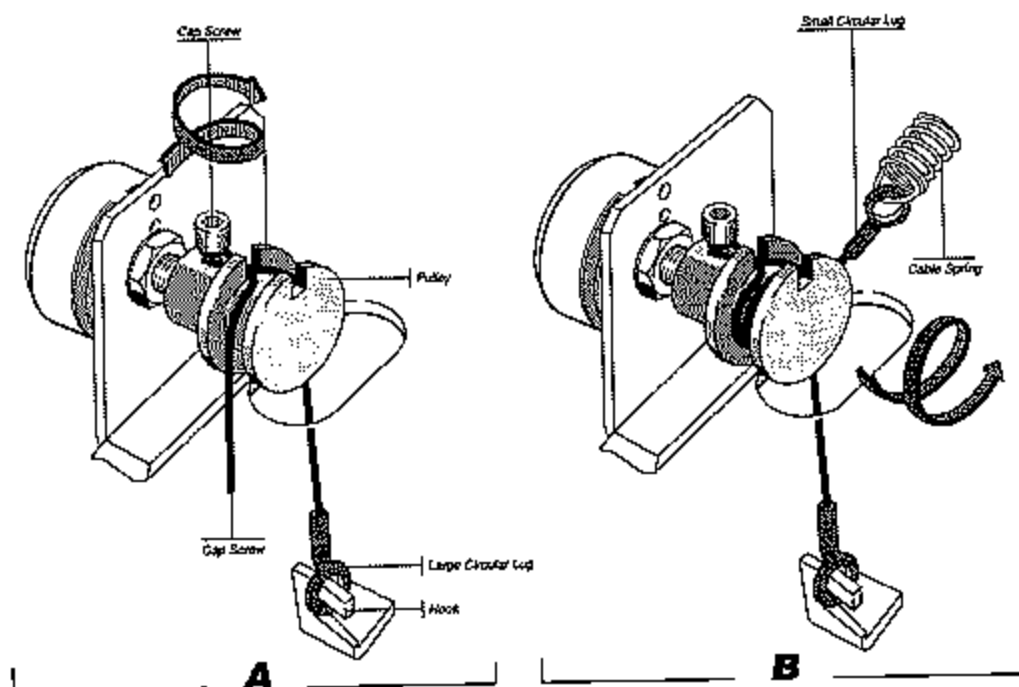
## Gas Pedal Assembly

The most likely cause of gas pedal assembly failure is the pulley cable breaking or unwinding. Check the suggestions in Table 3-8 before repairing the gas pedal.

### Lubricating the Gas Pedal

Maintain the gas pedal assembly by lubricating at the points shown in Figure 3-11.

1. Turn off the power and unplug the game.
2. From the front of the cabinet, unscrew the seven Phillips-head screws and pull the gas pedal assembly forward. Disconnect the simulator harness from the assembly. Take the assembly out.
3. Lubricate the pivot pin and surrounding area, the



**Figure 3-10 Rewinding the Gas Pedal Pulley Cable**

spring cable, and pulley with dry Teflon spray. Check that the cable is wound correctly. See Figure 3-10.

- Put the gas pedal back in the simulator and re-connect it to the simulator harness connector. Make sure that the ground wire is connected. Screw in the Phillips-head screws that hold the assembly in the simulator.

## Rewinding the Gas Pedal Pulley Cable

The pulley cable may become disconnected during normal use and must be rewound. If you remove or replace the cable spring, you may also have to rewind the pulley cable. If the cable is cut or frayed, replace it.

- Turn off the power and unplug the game.
- Remove the pedal assembly from the simulator by taking out the seven Phillips-head screws that hold the pedal assembly box in the simulator. Disconnect the pedal from the simulator harness.
- Lay the pedal assembly on the bench, with the extension spring at the front. See Figure 3-11 for an illustration of the pedal.
- Put the large circular lug on one end of the cable around the hook on the pedal. See Figure 3-10, Step A. Thread the rest of the cable up through the hole in the base plate. Wrap the cable counterclockwise around the pulley up to the cap screw. Put the cable through the notch and wrap it once, clockwise, around the cap screw in the pulley. (This screw must be at the top of the pulley. If it is not, turn the pulley so it is.)
- Bring the cable back through the notch and wrap it twice, counterclockwise, around the pulley. Do not wrap the cable over itself. See Figure 3-10, Step B. Hook the small circular lug onto the cable spring. The cable spring should be stretched out. Push the pedal a few times to make sure the cable returns the pedal to the rest position.
- Lubricate the pivot pin, springs, cable, and pulley with dry Teflon spray.
- Install the pedal in the simulator and re-connect the harness. Make sure the ground wire is attached.
- Go to the *Set Controls* screens in the self-test and re-initialize all the controls.

### NOTE

*You must go through the Set Controls screens in the self-test because you repaired the pedal. Otherwise, the simulator will not work correctly.*

## Replacing the Gas Pedal Cable Spring

The gas pedal cable spring may break or become weak. Before you replace the spring, first make sure the cable is wound correctly around the pulley since this is a more likely cause of gas pedal failure.

1. Turn off the power and unplug the game.
2. Remove the pedal assembly from the simulator by taking out the seven Phillips-head screws that hold the pedal assembly box in the simulator. Disconnect the pedal from the simulator harness.
3. Lay the pedal assembly on the bench, with the extension spring pointing up at the front. See Figure 3-11 for an illustration of the pedal.
4. Disconnect the cable from the cable spring. Remove the spring and replace it.
5. If the cable is frayed or cut, replace it.
6. Put the large circular lug on one end of the cable around the hook on the pedal. See Figure 3-10, Step A. Thread the rest of the cable up through the hole in the base plate.  
Wrap the cable counterclockwise around the pulley up to the cap screw. Put the cable through the notch and wrap it once, clockwise, around the cap screw in the pulley. (This screw must be at the top of the pulley. If it is not, turn the pulley so it is.)
7. Bring the cable back through the notch and wrap it twice, counterclockwise, around the pulley. Do not wrap the cable over itself. See Figure 3-10, Step B. Hook the small circular lug onto the cable spring. The cable spring should be stretched out. Push the pedal a few times to make sure the cable returns the pedal to the rest position.
8. Lubricate the pivot pin, springs, cable, and pulley with dry Teflon spray.
9. Install the pedal in the simulator and re-connect the harness. Make sure the ground wire is attached.

10. Go to the *Set Controls* screens in the self-test and re-initialize all the controls.

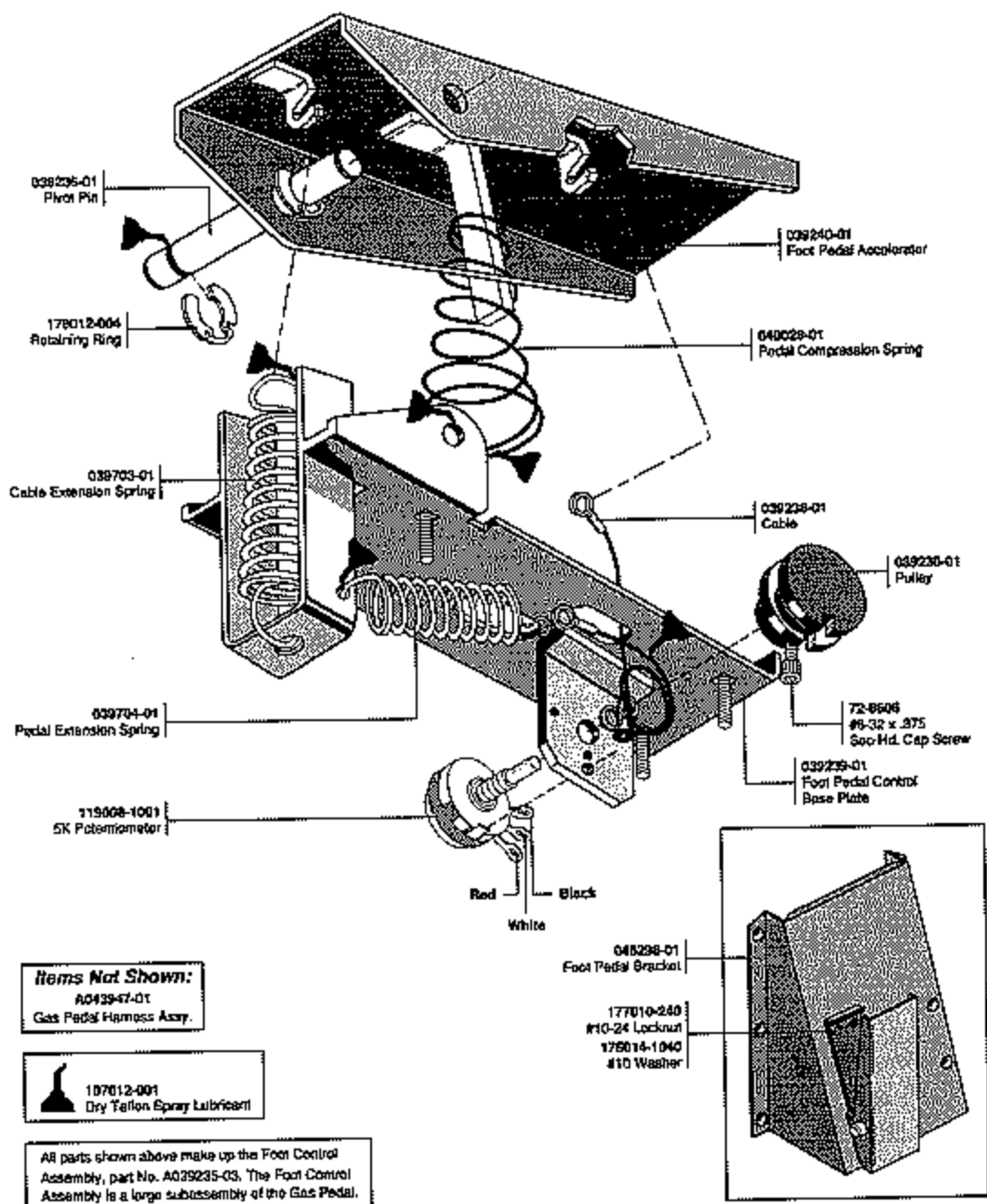
## Replacing the Gas Pedal Potentiometer

Replace the potentiometer if you have followed the flowchart in Figure 3-7 and decided that the potentiometer is the problem. However, when you take the gas pedal out of the simulator, first check if the springs are broken or if the cable is broken or unwound from the pulley before you replace the potentiometer.

1. Turn off the power and unplug the game.
2. Remove the pedal assembly from the simulator by taking out the seven Phillips-head screws that hold the pedal assembly box in the simulator. Disconnect the pedal from the simulator harness.
3. Lay the pedal assembly on the bench, with the extension spring pointing up at the front. See Figure 3-11 for an illustration of the pedal.
4. Disconnect the cable from the cable spring. Loosen the screw on the pulley and remove the pulley from the potentiometer shaft.
5. Take off the potentiometer by removing the nut with a 1/2-inch wrench. Take the wires off the potentiometer.
6. Put a new potentiometer on the bracket in the base plate, with the three terminals facing towards you and the flat of the potentiometer shaft facing up. Tighten the nut.
7. Solder the harness wires onto the potentiometer in this order: red on the left terminal, white on the middle, and black on the right.
8. Put the pulley on the potentiometer shaft and tighten the screw in the hub on the flat of the potentiometer shaft.
9. Put the large circular lug on one end of the cable around the hook on the pedal. See Figure 3-10,

**Table 3-8 Troubleshooting the Gas Pedal Assembly**

| Problem                                       | Solution   |
|---|--|
| Gas pedal does not work or works erratically. | <ol style="list-style-type: none"> <li>1. Go through the <i>Set Controls</i> screen in the self-test.</li> <li>2. If that doesn't work, see Figure 3-7 for more information.</li> <li>3. Check the <i>Control Inputs</i> screen. If the gas line does not change as you press the pedal down, then you may need to replace the potentiometer, rewind or replace the pulley cable, or replace a broken spring.</li> <li>4. Check voltage level to boards. See Table 3-3.</li> </ol> |
| Does not return to rest position.             | <ol style="list-style-type: none"> <li>1. Is the gas pedal lubricated? Follow the procedure under <i>Lubricating the Gas Pedal</i>.</li> <li>2. Check the pulley cable.</li> <li>3. Check for a broken extension spring, shown in Figure 3-9.</li> </ol>   |



**Figure 3-11 Maintaining the Gas Pedal**

Step A. Thread the rest of the cable up through the hole in the base plate.

Wrap the cable counterclockwise around the pulley up to the cap screw. Put the cable through the notch and wrap it once, clockwise, around the cap

screw in the pulley. (This screw must be at the top of the pulley. If it is not, turn the pulley so it is.)

10. Bring the cable back through the notch and wrap it twice, counterclockwise, around the pulley. Do not wrap the cable over itself. See Figure 3-10, Step B.



Hook the small circular lug onto the cable spring. The cable spring should be stretched out. Push the pedal a few times to make sure the cable returns the pedal to the rest position.

11. Lubricate the pivot pin, springs, cable, and pulley with dry Teflon spray.
12. Install the pedal in the simulator and re-connect the harness. Make sure the ground wire is attached.
13. Go to the *Set Controls* screens in the self-test and re-initialize all the controls.

---

### NOTE

*You must go through the Set Controls screens in the self-test because you replaced the potentiometer. The simulator will not work correctly if you do not set the controls.*

---

## Replacing a Broken Spring on the Gas Pedal

It is unlikely that these springs will be sprung or fatigued. However, if they are, follow the instructions below.

1. Turn off the power and unplug the game.
2. Remove the pedal assembly from the simulator by taking out the seven Phillips-head screws that hold the pedal assembly box in the simulator. Disconnect the pedal from the simulator harness.
3. Lay the pedal assembly on the bench, with the extension spring pointing up at the front. See Figure 3-11 for an illustration of the pedal.
4. Disconnect the cable from the cable spring.
5. Remove the two retaining rings from either end of the pivot pin and take out the pivot pin.
6. Take out the springs. If you replace the compression spring, be sure that the large end of the spring

is against the base plate when you put the pedal assembly together again.

7. Install the new spring and replace the pivot pin.
8. Rewind the pulley cable in the following way:
  - a. Put the large circular lug on one end of the cable around the hook on the pedal. See Figure 3-10, Step A. Thread the rest of the cable up through the hole in the base plate.
 

Wrap the cable counterclockwise around the pulley up to the cap screw. Put the cable through the notch and wrap it once, clockwise, around the cap screw in the pulley. (This screw must be at the top of the pulley. If it is not, turn the pulley so it is.)
  - b. Bring the cable back through the notch and wrap it twice, counterclockwise, around the pulley. Do not wrap the cable over itself. See Figure 3-10, Step B. Hook the small circular lug onto the cable spring. The cable spring should be stretched out. Push the pedal a few times to make sure the cable returns the pedal to the rest position.

9. Lubricate the pivot pin, springs, cable, and pulley with dry Teflon spray before you put the assembly back in the simulator.
10. Install the pedal in the simulator and re-connect the harness. Make sure the ground wire is attached.
11. Go to the *Set Controls* screens in the self-test and re-initialize the controls.

---

### NOTE

*You must go through the Set Controls screens in the self-test because you replaced the potentiometer. The simulator will not work correctly if you do not set the controls.*

---

## Shifter Assembly

If you have problems with the shifter, check Table 3-9, *Troubleshooting the Shifter Assembly*.

If the shifter is not working but you cannot repair it immediately, you can disable the shifter circuit. When the shifter circuit is disabled, the simulator drives only with the automatic transmission, even if the driver chooses manual transmission. The driver can shift, but this has no effect. Disable the shifter circuit only as a *temporary* measure. Repair the shifter as soon as possible.

To disable the shifter, go to the screen *Disable Broken Controls* in the self-test. Choose *broken* under shifter. Remember to change this setting back to *working* when you repair the shifter.

## Installing a New Shifter Boot

The shifter is shown in Figure 3-13.

1. Remove the roll pin in the knob using a 1/8-inch punch and take off the knob.
2. Remove the four tamperproof screws that hold the boot cover plate on the shifter case. Lift off the boot and the cover plate.
3. Discard the boot.
4. Replace the double-sided tape in between the holes on the top of the shifter gate. If necessary, also replace the double-sided tape on the shaft where the hole of the boot attaches.
5. Replace the boot.
6. Install the boot cover plate and the screws. Secure the knob back on the shaft by tapping in the roll pin.

## Replacing a Shifter Potentiometer

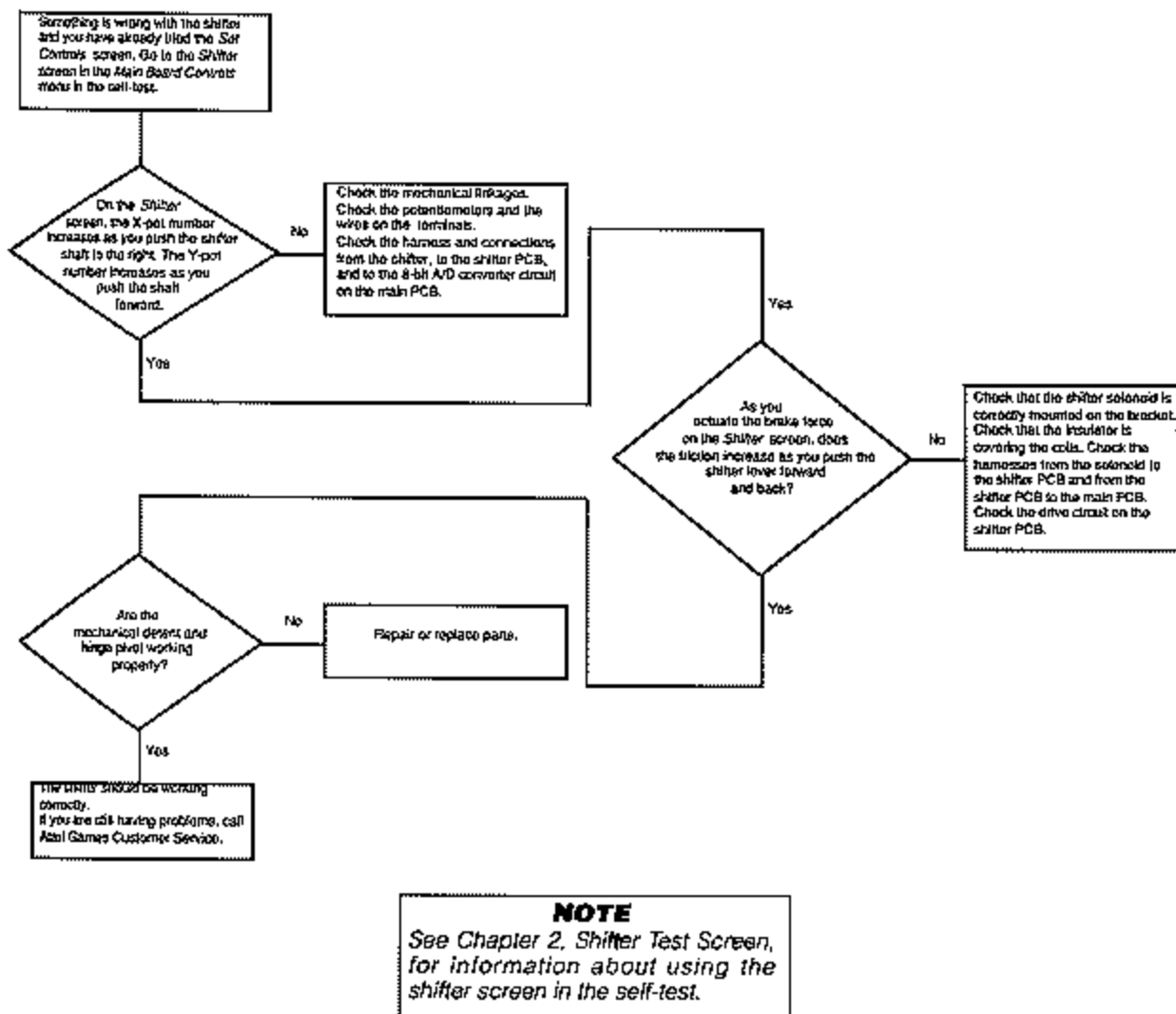
If the shifter acts erratically, follow the flowchart in Figure 3-12 to make sure that the problem is with the potentiometers. Before you replace the potentiometers, check that the screws on the ends of the roll link and the pitch link are tight but still allow free movement. If you tighten these screws, do the *Set Controls* screens in the self-test to see if the problem is solved.

The shifter is shown in Figure 3-13.

1. Remove the roll pin in the knob using a 1/8 inch punch and take off the knob.
2. Remove the four tamperproof screws that hold the boot cover plate on the shifter case. Lift off the boot, the cover plate, and the shifter gate which has the shift pattern in it.
3. Remove the screw on the tie wrap that holds the shifter harness on the side of the case.
4. Unscrew the nut on the carriage bolt on the left side of the case and slip the long thin pitch bar off the bolt.
5. Inside the case, remove the cotter pin on the right side of the pivot shaft.
6. Push the pivot shaft out of the case through the hole on the outside of the cabinet. Use a screwdriver or a pencil. Disconnect the six-pin connector on the simulator harness from the shifter and the two wires from the solenoid. Lift the shifter assembly out of the case.
7. Test the locknuts on the end of the roll link and the pitch link and the shoulder screws on the thin roll bar and pitch bar. These should be tight but still allow free movement of the bar and attached link. If these are fine, then go to the next steps. Otherwise, tighten them, assemble the shifter, do

**Table 3-9 Troubleshooting the Shifter Assembly**

| Problem   | Solution   |
|---|--|
| Shifter does not work or works erratically.               | <ol style="list-style-type: none"> <li>1. Go through the <i>Set Controls</i> screen in the self-test.</li> <li>2. See Figure 3-12 to determine the cause of the problem.</li> <li>3. Check voltage level to the main PCB. See Table 3-3.</li> <li>4. Check the F4 fuse on the power supply. (If this is blown, then the brake pedal will not work either.)</li> <li>5. Check the setting of the shifter option on the <i>Disable Broken Controls</i> screen. If the shifter potentiometer is not working, set it to <i>broken</i> and repair as soon as possible. If it is working, set the option to <i>working</i>.</li> </ol> |
| Moves in and out of gear freely without using the clutch. | Check the shifter PCB and magnet.  |
| Shifter squeaks and squeals.                              | Some noise is normal. If you think the noise is excessive, replace the magnet or the magnet plate.   |

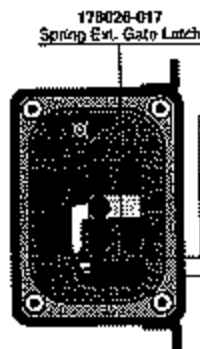


**Figure 3-12 Shifter Is Not Working or Working Erratically and You Have Already Tried the *Set Controls* Screens**

- the *Set Controls* screens, and check the results on the *Control Inputs* screen.
8. If the screws and nuts are tight, disconnect the harness from the potentiometer that you are replacing. Loosen the 6-32 screw of the roll link and slip off the potentiometer shaft. Loosen the nut on the potentiometer shaft with a 1/2-inch flat wrench. Remove the potentiometer.

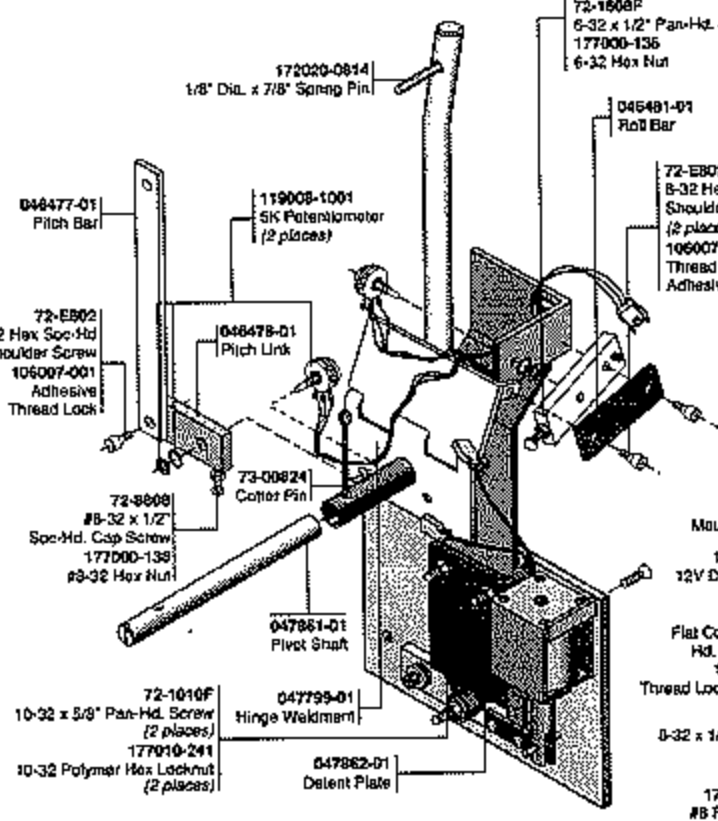
9. Solder the harness to the new potentiometer. With the shaft facing you and the terminals pointing down, solder the black wire to the left terminal, the white to the middle, and the red to the right.
10. Install the new potentiometer. Put the potentiometer key in the key slot in the shifter. Tighten the nut.

**Items Not Shown:**  
 A047753-01  
 Shifter Jumper Assy  
 72-8808  
 8-32 x 3/8" Soc-Hd. Cap Screw

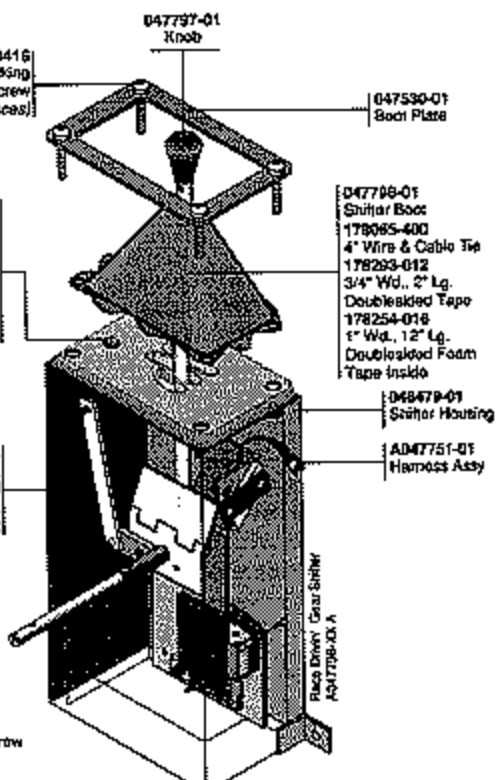


- 178026-017  
Spring Ext., Gate Latch
- 046476-244  
Shifter Gate
- 75-048S  
#8 Lock-Washer
- 72-8010  
10-32 x 5/8"  
Soc-Hd. Cap Screw
- 175014-1031  
#8 Flat Washer
- 046424-01  
Gate Latch
- 177000-132  
#4-40 Hex Nut  
(2 places)
- 72-1408F  
4-40 x 1/2" Pan-Hd. Screw  
(2 places)

**Detail of shifter gate**

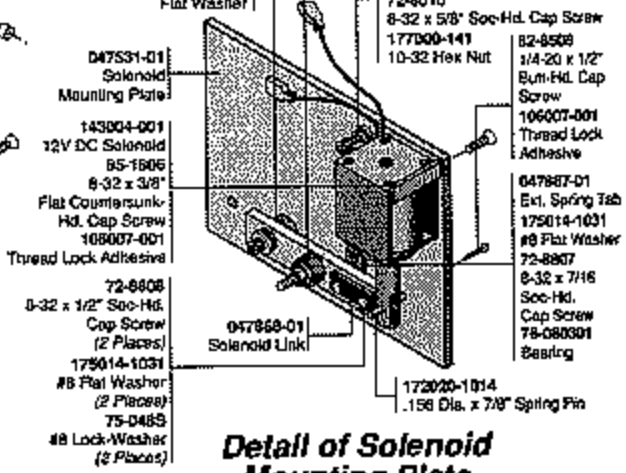


- 172020-0814  
1/8" Dia. x 7/8" Spring Pin
- 048477-01  
Pitch Bar
- 119008-1001  
5K Potentiometer  
(2 places)
- 048478-01  
Pitch Link
- 72-E802  
8-32 Hex Soc-Hd.  
Shoulder Screw
- 106007-001  
Adhesive  
Thread Lock
- 72-8808  
#8-32 x 1/2"  
Soc-Hd. Cap Screw
- 177000-139  
#8-32 Hex Nut
- 73-00824  
Cotter Pin
- 047961-01  
Pivot Shaft
- 72-1010F  
10-32 x 5/8" Pan-Hd. Screw  
(2 places)
- 177010-241  
10-32 Polymer Hex Locknut  
(2 places)
- 047799-01  
Hinge Weldment
- 047962-01  
Detent Plate
- 048482-01  
Roll Link
- 72-1808P  
6-32 x 1/2" Pan-Hd. Screw
- 177000-136  
6-32 Hex Nut
- 048481-01  
Roll Bar
- 72-E802  
8-32 Hex Soc-Hd.  
Shoulder Screw  
(2 places)
- 106007-001  
Thread Lock  
Adhesive
- 047963-01  
Lever Spacer
- 72-8514  
1/4-20 x .87  
Soc-Hd. Cap Screw
- 75-04S  
#1/4" Lock Washer
- 175014-1050  
Flat Washer
- 047964-01  
Detent Lever
- 047964-01  
Detent Roller
- 047965-01  
Lever Spacer
- 72-8520B  
1/4-20 x 1 1/4"  
Soc-Hd. Cap Screw
- 175014-1050  
Flat Washer
- 177010-244  
1/4-20 Polymer Hex Locknut
- 178026-022  
Extension Spring
- 178066-834  
PVC Tubing
- 72-8010  
8-32 x 5/8" Soc-Hd. Cap Screw
- 177000-141  
10-32 Hex Nut
- 82-8508  
1/4-20 x 1/2"  
Bun-Hd. Cap  
Screw
- 106007-001  
Thread Lock  
Adhesive
- 047967-01  
Ext. Spring Tab
- 175014-1031  
#8 Flat Washer
- 72-8807  
8-32 x 7/16  
Soc-Hd.  
Cap Screw
- 78-080301  
Bearing
- 172020-1014  
.158 Dia. x 7/8" Spring Pin



- 047797-01  
Knob
- 176025-441G  
1/4-20 x 1" Self-Locking  
Bun-Hd Cap Screw  
(4 places)
- 047530-01  
Boot Plate
- 72-1810F  
8-32 x 1 1/8" Pan-Hd Screw
- 175014-1031  
#8 Flat Washer
- 177010-238  
6-32 Polymer Hex Locknut
- 046440-01  
Latch Bearing
- 047798-01  
Shifter Boot
- 178065-400  
4" Wires & Cable Tie
- 178293-012  
3/4" Wd., 2" Lg.  
Doubleided Tape
- 178254-018  
1" Wd., 12" Lg.  
Double-sided Foam  
Tape inside
- 048479-01  
Shifter Housing
- AD47751-01  
Harness Assy
- 177010-264  
1/4-20 Polymer Hex Locknut  
(2 places)
- 73-8529B  
1/4-20 x 1 3/4" Carriage Bolt

**Detail of Solenoid Mounting Plate**



- 047531-01  
Solenoid  
Mounting Plate
- 143804-001  
12V DC Solenoid
- 85-1806  
8-32 x 3/8"  
Flat Countersunk-  
Hd. Cap Screw
- 169007-001  
Thread Lock  
Adhesive
- 72-8808  
8-32 x 1/2" Soc-Hd.  
Cap Screw  
(2 Places)
- 175014-1031  
#8 Flat Washer  
(2 Places)
- 75-048S  
#8 Lock-Washer  
(2 Places)
- 047968-01  
Solenoid Link
- 178026-022  
Extension Spring
- 178066-834  
PVC Tubing
- 72-8010  
8-32 x 5/8" Soc-Hd. Cap Screw
- 177000-141  
10-32 Hex Nut
- 82-8508  
1/4-20 x 1/2"  
Bun-Hd. Cap  
Screw
- 106007-001  
Thread Lock  
Adhesive
- 047967-01  
Ext. Spring Tab
- 175014-1031  
#8 Flat Washer
- 72-8807  
8-32 x 7/16  
Soc-Hd.  
Cap Screw
- 78-080301  
Bearing

**Figure 3-13 Maintaining the Shifter**

- Put the shifter assembly back in the case. Attach the pitch bar to the carriage bolt at the top of the case with the locknut.
- Attach the simulator harness assembly. Install the screw through the tie wrap on the shifter harness on the side of the shifter case. Connect the two solenoid wires.
- Line up the tube for the pivot shaft with the holes in the case for the pivot shaft. Insert the shaft into the case from the driver's side with the cotter pin hole and the slotted end on the left.
- With the pivot shaft through both sides of the case, put a screwdriver on the slotted end and turn the shaft until the holes in the shaft line up with the holes in the tube. Put in the cotter pin. Do not bend the legs of the cotter pin.
- Put the shifter gate back on, with the latch and the spring facing down. Replace the double-sided tape in between the holes on the top of the shifter gate. If necessary, also replace the double-sided tape on the shaft where the hole of the boot attaches.
- Put the boot on, then the boot cover plate. Install the four tamperproof screws. Install the knob and secure by tapping in the roll pin.
- Go into the self-test and perform the *Set Controls* screens.

### NOTE

You must perform the *Set Controls* screens because you replaced the potentiometer. Otherwise the simulator will not operate correctly.

## Replacing the Solenoid

If the shifter shifts without the clutch pedal being pressed, you may want to replace the solenoid. Shifting without the clutch does not impair the game's performance. You can replace the solenoid itself as described here or order the solenoid assembly (part no. A048306-01). Note that in order to remove the solenoid housing, you must remove the shifter housing from the game. The solenoid is shown in Figure 3-13.

- To remove the shifter housing from the game, first remove the two screws and the reinforcement plate on the outside of the cabinet.
- Take out the Phillips-head screws on the back edge of the floor trim, which is the strip of metal across the middle of the floor. Remove the three Phillips-head screws along the front of the simulator under the rubber floor mat.
- Turn the seat out of the simulator as far as it will go. Use two screwdrivers to lift and pry up the front corner of the floor. Take out the floor.

- Remove the locknuts that hold the shifter on the seat assembly frame. Remove the shifter.
- Remove the shifter assembly from the housing by following steps 1 through 6 in the preceding section, *Replacing a Shifter Potentiometer*.
- Disconnect the solenoid wires from the harness.
- Remove the two button-head screws from the housing and lift the solenoid mounting plate out.
- Remove the roll pin to free the solenoid plunger. Remove the four flat screws to remove the solenoid from the plate.
- Replace the solenoid and reassemble following the reverse procedure.

## Seat Assembly

The seat assembly has two controls: the magnet, which locks the seat in position during the game and slows the seat movement if the driver pushes the seat out of the game very fast; and the potentiometer, which senses the position of the seat and adjusts the steering wheel force.

The steering wheel force becomes lighter as the seat is moved closer to the dashboard. This is so small children, who sit very close, can turn the wheel easily.

The seat assembly does not require any regular maintenance, other than checking for obstructions around the seat movement area on the simulator floor and inside on the metal plate the magnet rides on. If you have difficulties with the seat, see Table 3-10, *Troubleshooting the Seat Assembly*.

Three flow charts help you troubleshoot seat assembly problems. Depending on the type of problem you have, use the following flow charts:

- If the seats moves erratically, follow the flowchart in Figure 3-7.
- If the seat does not lock when it should, follow the flowchart in Figure 3-13.
- If the seat locks when it should not, follow the flowchart in Figure 3-14.

## Replacing the Seat Rod End Bearings

Replace both rod ends if the seat turns with difficulty, or the seat squeaks as it rotates. The seat assembly is shown in Figure 3-16.

- Remove the four tamperproof screws that hold each end plate on the mounting box. Take off the end plates. Also remove the bottom cover on the mounting box.

2. The rod ends are attached to the pivot blocks with shoulder screws. Use an Allen-head wrench and a flat wrench to remove the screws and nuts.
3. Take out the rod ends and the pivot arm. Remove both rod ends from the pivot arm. Save the nut on the right rod end.
4. Insert the new right rod end into the pivot arm with the nut on the threads. (The left rod end has left-hand threads and will not fit on the right end.)
5. Carefully set the rod ends and pivot arm length to the following dimensions so that the seat assembly rotates correctly.
  - The distance from the center of the hole in left rod end to the point where it goes into the end of the pivot arm must be exactly 1.25 inches. This is for clearance.
  - The distance from center of the hole in one rod end to the center of the hole in the other rod end should be exactly 11.25 inches.
6. Do not tighten the nut on the right rod end yet.
7. Put the rod ends and pivot arm into the seat mounting box, with the right rod end on the right side as you face the simulator. Tighten the socket-head screws and nuts to hold the rod ends on the pivot blocks.
8. Turn the mounting box until it is parallel to the front of the simulator. The sides of the seat mount-

ing platform should be parallel with the sides of the mounting box too.

If they are not, then screw the pivot arm in or out of the pivot blocks until the sides are parallel. When the mounting box and seat mounting platform sides are parallel to each other and to the sides of the simulator, tighten the nut on the right rod end.

Check the alignment a final time.

9. Install the end plates on the mounting box with the tamperproof screws. Put the bottom cover back on.

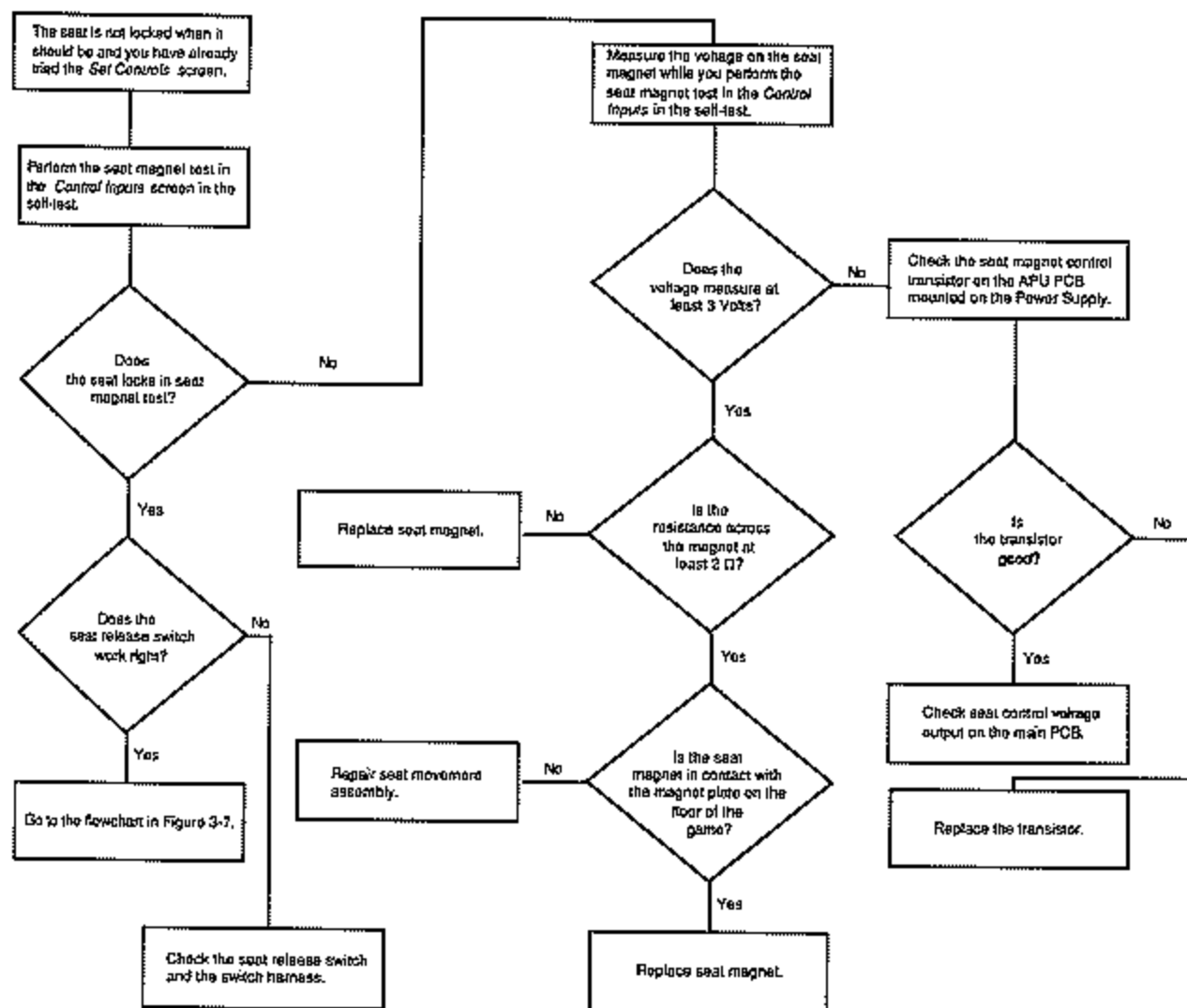
## Replacing Bearings on the Seat Pivot

The seat pivot bearings turns the seat (not the mounting box). Replace the seat pivot bearings if the seat twists or jiggles excessively or you can pull the seat up and down. (If both the seat *and* the mounting box twist and move up and down, the main bearings may need to be replaced.) The seat assembly is shown in Figure 3-16.

1. Remove the tamperproof screws that hold each end plate of the mounting box on the seat assembly. Take off the end plates. Remove the bottom cover on the mounting block.
2. Using a punch, hammer out the spring pin in the seat pivot.

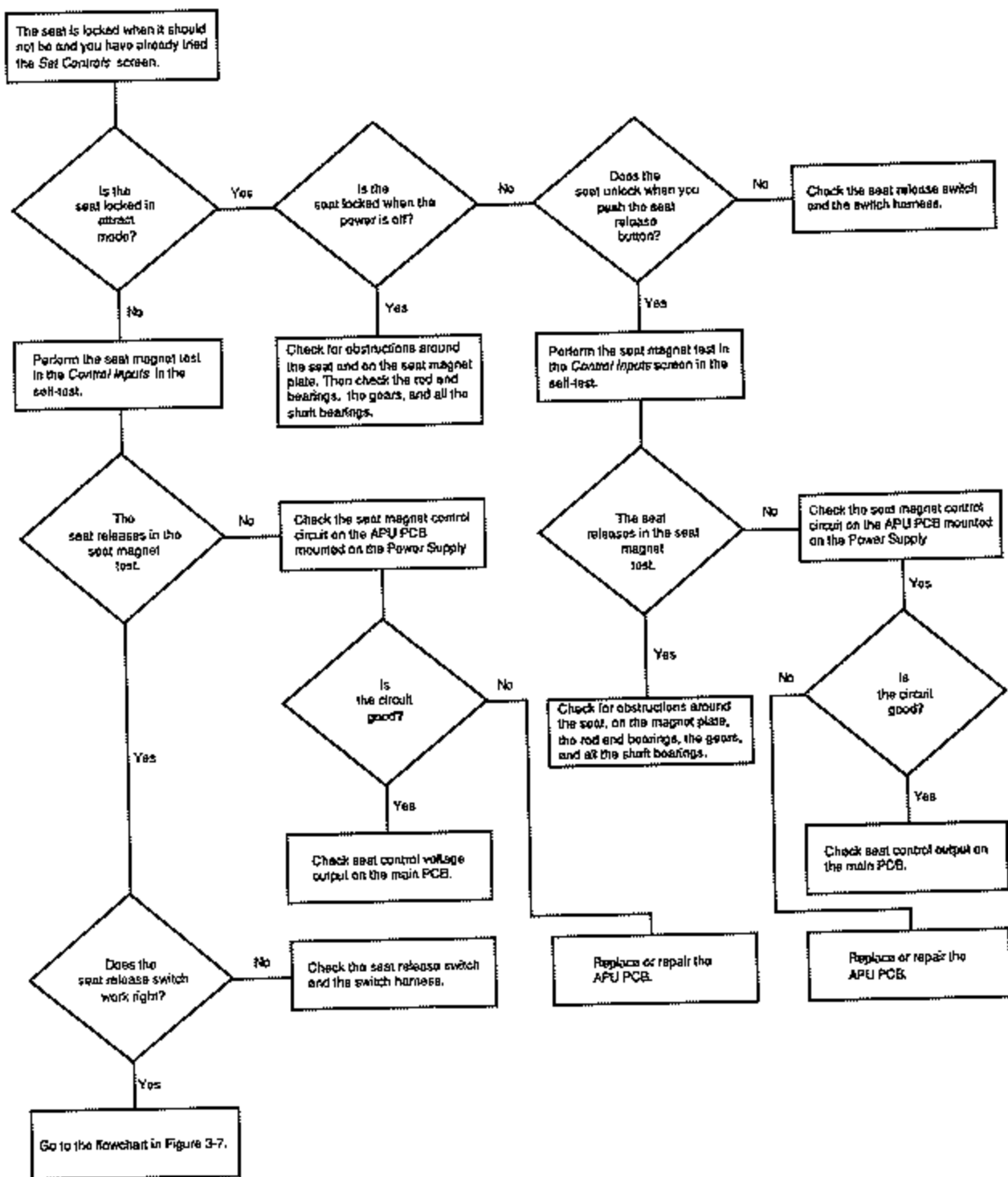
**Table 3-10 Troubleshooting the Seat Assembly**

| Problem  | Solution   |
|--|--|
| Action is erratic.   | <ol style="list-style-type: none"> <li>1. Go through the <i>Set Controls</i> screen in the self-test.</li> <li>2. See Figure 3-7, 3-12, or 3-13 to determine the cause of the problem.</li> <li>3. Check voltage level to the main PCB. See Table 3-3.</li> <li>4. Check the setting of the seat option on the <i>Disable Broken Controls</i> screen. If the seat potentiometer is not working, set it to <i>broken</i> and repair as soon as possible. If it is working, set the option to <i>working</i>.</li> </ol> |
| Does not turn easily, does not push in and out, or squeaks.        | <ol style="list-style-type: none"> <li>1. Check for obstructions on the simulator floor and inside the bottom of the simulator.</li> <li>2. Check the rod end bearings.</li> <li>3. Check the shaft bearings on the seat shaft.</li> <li>4. Check the main seat bearings.</li> <li>5. Check the gears on the seat assembly.</li> </ol>   |
| Seat does not lock in place when it should.                        | <ol style="list-style-type: none"> <li>1. Go through the <i>Set Controls</i> screen in the self-test.</li> <li>2. See Figure 3-12 to find out the cause.</li> <li>3. Check the APU PCB.</li> </ol>   |
| Seat is locked when it should not be.                              | <ol style="list-style-type: none"> <li>1. Go through the <i>Set Controls</i> screen in the self-test.</li> <li>2. See Figure 3-14 to find out the cause.</li> <li>3. Check the APU PCB.</li> </ol>   |
| Seat jiggles or twists excessively, and can be pulled up and down. | Does the seat alone do this, or do the seat and the mounting arm jiggle and twist together? If only the seat does it, replace the bearings on the seat pivot. If both the seat and the mounting arm jiggle, twist, and move up and down, replace the main seat bearings.   |



**Figure 3-14 Seat Is Not Locked When It Should Be And You Have Already Tried the Set Controls Screens**

3. When the pin is out of the seat pivot, pull up on the seat and remove it.
4. You will need to take the seat mounting box to a machine shop to do the following items:
  - a. Remove the old bearings. (They are press fit.)
  - b. Cut down one of the new bearings to 0.6 inch long. This will be the bottom bearing. (You can use a bearing on the bottom that has not been cut down, but it may catch someone's foot.)
  - c. Turn the bearings to the following specifications.
    - A shaft with a diameter of 1.249 inches should rotate freely in the bearing when a torque of 10 inch-pounds is applied.
    - A shaft with a diameter of 1.254 inches must *not* fit in the bearing.
  - d. Press the bearings on the pivot of the seat mounting plate.
5. Insert the pivot through the new top bearing, the spacer tube, the pivot block, two washers, and the new bottom bearing.
6. Line up the holes for the spring pin in the seat pivot with the holes in the pivot block. Make sure the seat faces the right direction. Put in the spring pin. (You might want to use a 3/8-inch shaft or shoulder screw to hold the position while you are putting in



**Figure 3-15 Seat Is Locked When It Should Not Be And You Have Already Tried the Set Controls Screens**



the spring pin.)

7. Make sure the pin is flush with the outer edges of the pivot block.
8. Put the end plate back on and install the four tamperproof screws in each plate.

## Replacing the Main Seat Bearings

The main seat bearings are located between the base of the simulator and the seat mounting box. Replace them if the seat mounting box is twisting or jiggling or you can pull the box up and down. (If *only* the seat twists and moves up and down, the seat pivot bearings, not the main bearings, may need to be replaced.) The seat assembly is shown in Figure 3-16.

To replace these bearings, remove the simulator floor and take out the seat assembly. You will need someone to help you.

1. Take out the Phillips-head screws on the back edge of the floor trim, which is the strip of metal across the middle of the floor. Remove the three Phillips-head screws along the front of the simulator under the rubber floor mat.
2. Turn the seat out of the simulator as far as it will go. Use two screwdrivers to lift and pry up the front corner of the floor. Take out the floor.
3. Before you can take out the seat mechanism, take out the coin module and the shifter. Open the top and bottom coin doors and take off the four locknuts on the carriage bolts on the side of the cabinet.
4. Disconnect the harness from the coin module. Remove the bolts and the coin module.
5. Now take out the shifter. Loosen the self-locking screw in the shifter knob and take off the knob.
6. Remove the four tamperproof screws that hold the shifter boot cover plate on the shifter case. Lift off the boot, the cover plate, and the shifter gate. Disconnect the shifter harness.
7. Take off the locknuts on the two tamperproof screws that hold the shifter on the side of the cabinet and remove the screws.
8. Remove the locknuts that hold the shifter on the seat assembly frame. Remove the shifter.
9. Disconnect the simulator harness from the seat assembly. Remove all the screws and nuts that hold the seat assembly in the simulator. Tip the seat back until the seat frame clear the floor. Push the seat assembly towards the pedals until the assembly is out from under the floor.

---

### CAUTION

*The gears and potentiometer are on the bottom of the assembly under the floor in front of the license plate. Do not damage these parts when you push the seat assembly forward and up.*

---

10. When the assembly is clear of the floor, pull the assembly out of the simulator.
- 

### WARNING

*The seat assembly is heavy. Be careful.*

---

11. Remove the four tamperproof screws that hold each end plate of the mounting box on the seat assembly. Take off the end plates. Remove the bottom cover on the mounting block.
12. Remove the rod ends and the pivot arm from the pivot block inside the mounting box. The rod ends are attached to the pivot blocks with shoulder screws. Use an Allen-head wrench and a flat wrench to remove the screws and nuts. Take out the rod ends and pivot arm and lay the assembly aside.
13. Remove the potentiometer bracket with the potentiometer gear and small gear from the bottom of the seat assembly.
14. Remove the large half gear on the bottom of the main shaft. You may want to turn the assembly on its side to do this.
15. Using a punch, hammer out the spring pin in the bottom of the main shaft in the magnet arm. Remove the magnet arm.
16. Turn the seat until you can pull the seat mounting box off the seat assembly frame.
17. Take the seat assembly frame to a machine shop to do the following items:
  - a. Remove the old bearings. (They are press fit.)
  - b. Turn the new bearings to the following specifications.
    - A shaft with a diameter of 1.624 inches should rotate freely in the bearing when a torque of 10 inch-pounds is applied.
    - A shaft with a diameter of 1.629 inches must not fit in the bearings.
  - c. Press the new bearings into the seat frame.
18. Insert the main shaft through the top bearing, the shaft holder, the bottom bearing, and the magnet arm.

19. Line up the hole in the shaft for the spring pin with the hole in the magnet arm. Make sure the seat faces the right direction. Install the spring pin.
20. Put the rod ends and pivot arm assembly back into the seat mounting box, with the right rod end on the right side. Tighten the shoulder screws and nuts to hold the rod ends on the pivot blocks. Do not install the end plates or the bottom cover on the mounting box until the seat assembly is in the simulator.
21. Install the potentiometer bracket tightly on the bottom of the assembly.
22. Turn the small gear on the potentiometer shaft until its set screw is directly below the center terminal on the potentiometer.
23. Turn the seat so that when the large half gear is installed, the flat edge is opposite the small gear and is parallel to the sides of the assembly. Install the gear. Tighten the screws well.
24. Lift the assembly into the simulator. Push it forward and then back to ease it into position, under the floor. Be careful not to damage the gears and the potentiometer.
25. Install all the screws and nuts that hold the seat assembly in the simulator.
26. Reinstall the coin box and re-connect the harness.
27. Put the shifter back in the simulator. Put the lock-nuts on the tamperproof screws and the carriage bolts. Re-connect the harness.
28. Put the shifter gate back on, with the latch and the spring facing down. Then put on the boot with the foam cushion and install boot cover plate over the boot. Install the four tamperproof screws in the cover plate. Install the knob.
29. Re-install the floor. Put in the screws in the front of the floor and in the metal floor trim.
30. Turn the mounting box until it is parallel to the front of the simulator. The sides of the seat mounting platform should be parallel with the sides of the mounting box too.

If they are not, then screw the pivot arm in or out of the pivot blocks until the sides are parallel. When the mounting box and seat mounting platform sides are parallel to each other and to the sides of the simulator, tighten the nut on the right rod end.

Check the alignment a final time.

31. Install the end plates on the mounting box with the tamperproof screws. Put the bottom cover back on.
32. Enter the self-test and go through the *Set Controls* screens.

---

### NOTE

*You must go through the Set Controls screen in the self-test because you re-paired the seat assembly. If you do not do this, the seat will not work correctly.*

---

## Replacing the Gears on the Seat Assembly

If the seat is not turning easily or does not turn at all, do the following:

- Check for obstructions on the simulator floor.
- Check for obstructions on the magnet plate below the floor. Do the following:
  1. Take out the Phillips-head screws on the back edge of the floor trim, which is the strip of metal across the middle of the floor. Remove the three Phillips-head screws along the front of the simulator under the rubber floor mat.
  2. Turn the seat out of the simulator as far as it will go. Use two screwdrivers on the front corner of the floor to lift and pry the floor up. Take out the floor.
  3. Check for obstructions on the metal plate.
- Check the rod end bearings to make sure they are turning.
- Check for broken or missing gears. Lift up the simulator or turn it on its side, with the seat high, and look through the hole in the bottom of the simulator at the gears.

---

### WARNING

*This simulator weighs 750 pounds. Be extremely careful when you lift it, turn it, or work on it so that it does not fall.*

---

Look in the hole directly underneath the main seat shaft. You should see two gears. The small gear is mounted on the potentiometer. The large gear is mounted on the bottom of the main shaft.

If the gears are broken, cracked, or missing, you must replace them.

### Replacing the Small Gear

1. Remove socket-head screws which hold the potentiometer bracket in the simulator and pull the potentiometer bracket and the small gear a little ways out of the simulator. See Figure 3-16.
2. Loosen the small set screw on the small gear hub.

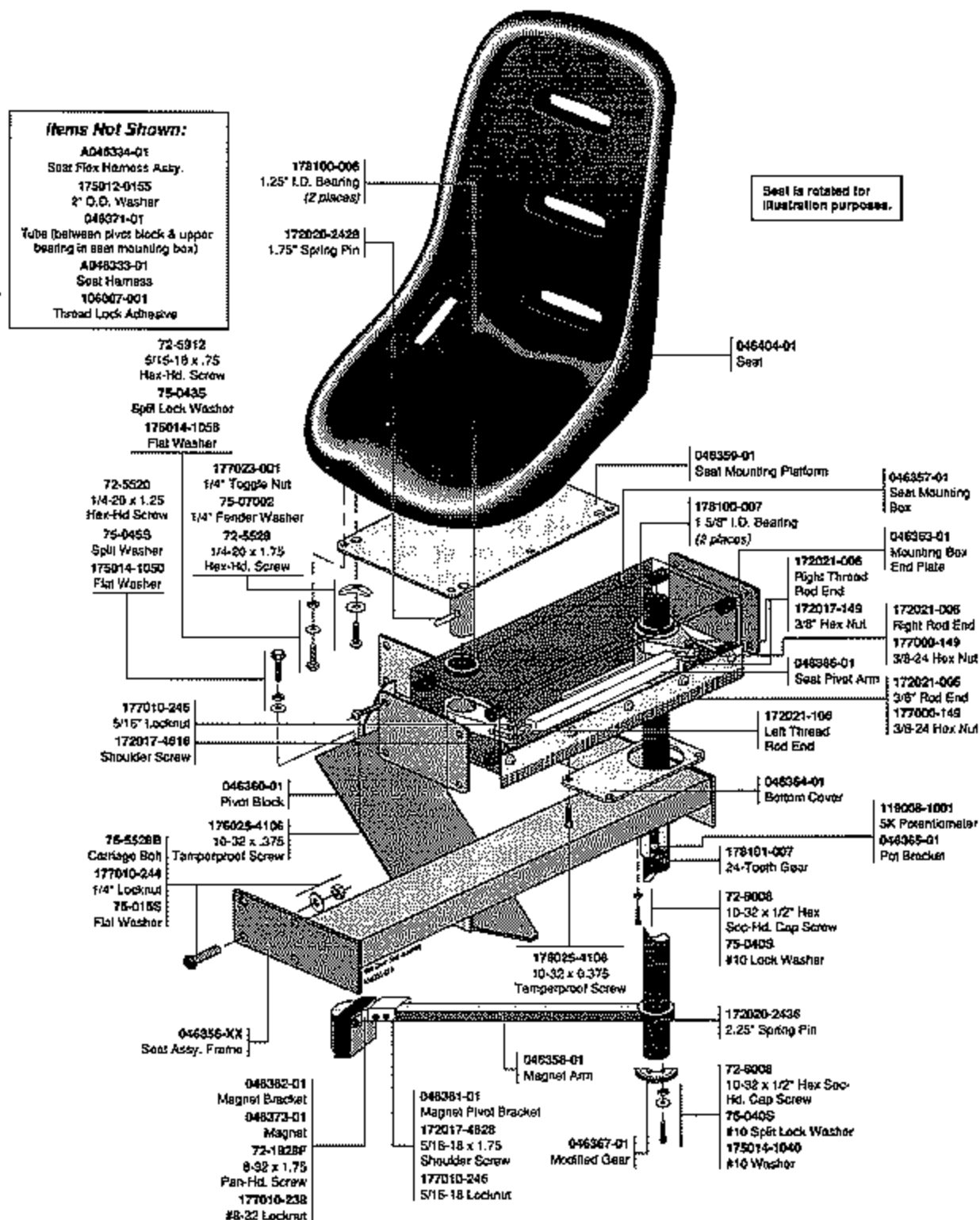


Figure 3-16 Maintaining the Seat Assembly

Use a 5/64-inch Allen wrench. Pull off the gear.

3. Turn the potentiometer in the bracket until the flat of the potentiometer shaft is directly below the center terminal.
4. Install the bracket in the simulator. Make sure the socket-head screws in the bracket are tight so it will not fall off.
5. Turn the seat so that the flat edge of the large half gear is opposite the potentiometer and is parallel to the sides of the simulator.
6. Install the new gear on the potentiometer shaft. Do not turn the shaft while you are putting the gear on. Put Loctite on the set screw. Tighten the set screw.
7. Put the simulator back on the floor.
8. Go into the self-test and perform the *Set Controls* screens.

### NOTE

*You must go through the Set Controls screen in the self-test. If you do not do this, the seat will not work correctly.*

### Replacing the Large Gear

1. Turn the seat so it will not move.
2. Remove the two socket-head screws holding the large gear on the main shaft. Take off the gear.
3. Install the new gear. Make sure that it meshes with the small gear. Tighten the socket-head screws so the gear will not fall off.
4. If the seat did not turn or move while you were replacing this gear, you are done. If the seat *did* move, do the following:
  - a. Take out the potentiometer bracket. Turn the small gear until its set screw is directly below the center terminal on the potentiometer.
  - b. Turn the seat so that the flat edge of the large half gear is parallel to the front of the simulator and is opposite the place where the potentiometer bracket is installed.
  - c. Install the potentiometer bracket in the simulator. Make sure the gears do not turn from the position they are set in. Tighten the socket-head screws on the bracket.
  - d. Put the simulator back on the floor.
5. Go into the self-test and perform the *Set Controls* screen.

### NOTE

*You must go through the Set Controls screen in the self-test. If you do not do this, the seat will not work correctly.*

## Replacing the Magnet on the Seat Assembly

Before you replace the magnet because the seat does not lock, go through the flowchart in Figure 3-13 to make sure the magnet is the problem.

You must remove the floor as described in steps 1 and 2, below, to get access to the magnet.

1. Remove the Phillips-head screws on the back of the floor trim, which is the strip of metal across the middle of the floor.
2. Remove the three Phillips-head screws along the front of the simulator under the rubber floor mat. Turn the seat out of the simulator as far as it will go. Pry up the floor using two screwdrivers. Remove the floor.
3. Turn the seat so you can see the magnet. The magnet is attached to the arm by a bracket that permits the magnet to move freely. Check the harness to the magnet.
4. After going through the flowchart in Figure 3-13 and determining that the magnet **must** be replaced, do the following steps.
5. Unscrew the two Phillips-head screws that hold the magnet on the magnet bracket and disconnect the harness.
6. Discard all the hardware that came with the new magnet and install the magnet with the Phillips-head screws and nuts. Re-connect the harness.
7. Re-install the floor. Insert the screws that hold the floor and the metal floor trim in the simulator.

## Replacing the Seat Potentiometer

Replace seat potentiometer if you have tried the *Set Controls* screens, you have followed the flowchart in Figure 3-7, and you are sure the problem is the potentiometer. (If the seat does not lock or locks when it should not, the problem is *not* the potentiometer.)

If you cannot repair the seat immediately, you can disable the seat potentiometer circuit. Read about what the seat potentiometer circuit does before you disable it with the *Disable Broken Controls* screen.

The seat potentiometer senses the location of the seat which determines the steering wheel force. The closer the seat is to the dashboard, the lighter the force is on the steering wheel. This is so small children, who sit very close, can turn the steering wheel easily. If you disable the seat potentiometer circuit, the steering wheel force is light in all positions. (If the *Steering Wheel Force* in the *Game Options* screen is set to *medium* (the default) the force will be light. If it is set to *light*, the force will be very light.)

Operate the simulator with the seat potentiometer circuit disabled *only a temporary measure*. Repair the seat potentiometer as soon as possible. Disable the circuit by going to the screen *Disable Broken Controls* in the self-test and choosing *broken under seat pot*. After you repair the potentiometer, remember to choose *working* again.

The potentiometer is mounted next to the end of the main shaft on the seat and has soldered connections. The seat is shown in Figure 3-16.

To replace the potentiometer, turn the simulator on its side or securely prop up the front of the simulator. In either case, you will need help, since the simulator is very heavy. You may find it easier to work on the simulator by turning it on its side, with the corner with the seat shaft high.

### WARNING

*This simulator weighs 750 pounds. Be extremely careful when you lift it, turn it, or work on it so that it does not fall.*

1. In the hole directly underneath the main seat shaft, you can see two gears. The small gear is mounted on the potentiometer in the potentiometer bracket. Remove the socket-head screws that hold the potentiometer bracket in the simulator and bring the potentiometer bracket out of the simulator.
2. Loosen the set screw on the small gear hub. Use a 5/64-inch Allen wrench.
3. Loosen the locknut on the potentiometer shaft and take the potentiometer out of the bracket. Take off the harness wires. Leave the ground wire attached to the bracket.
4. Put the new potentiometer in the bracket, and put the key in the hole in the bracket. The connectors should be on the same side as the ground wire bracket. Tighten the nut on the shaft.
5. Bend the potentiometer connectors up, but not so they touch the bracket. Solder the black wire nearest the ground wire, the yellow wire in the middle, and the red wire on the other side.
6. Install the bracket back in the game. Tighten the

socket-head screws on the bracket so it will not fall off.

7. Turn the potentiometer until the flat of the potentiometer shaft is directly below the center terminal.
8. Turn the seat so that the flat edge of the large half gear is opposite the potentiometer and is parallel to the sides of the simulator.
9. Install the new gear on the potentiometer shaft. Do not turn the shaft or the seat while you are putting the gear on. Put Loktite on the set screw. Tighten the set screw.
10. Put the simulator back on the floor.
11. Go into the self-test and perform the *Set Controls* screens.

## Video Display

If you have problems with the video display, check Table 3-11, *Troubleshooting the Video Display*, before you remove the display.

## Removing the Video Display

Perform the following procedure to remove the video display. (See Figure 3-16.)

1. Turn the simulator power off, but leave the power cord plugged in. Wait two minutes.

### WARNING High Voltage

*The video display contains lethal high voltages. To avoid injury, do not service this display until you observe all precautions necessary for working on high-voltage equipment.*

### X-Radiation

*The video display is designed to minimize X-radiation. However, to avoid possible exposure to soft X-radiation, never modify the high-voltage circuitry.*

### Implosion Hazard

*The cathode-ray tube may implode if struck or dropped. The shattered glass from the tube may cause injury up to six feet away. Use care when handling the display.*

2. While you wait, remove the six screws that hold the small top service panel on the simulator.
3. Disconnect the simulator harness to the attraction sign. Remove the large outside panel that the at-

traction sign is mounted on by taking off the carriage bolts that hold the panel on the simulator.

4. Discharge the high voltage from the cathode-ray tube (CRT). The display assembly contains a circuit for discharging the high voltage to ground when power is removed. However, to make certain, always discharge the display as follows:
  - a. Attach one end of a solid 18-gauge wire to a well-insulated screwdriver or wooden handle.
  - b. Attach the other end of the wire to an earth ground.
  - c. Quickly touch the blade end of the screwdriver to the CRT anode by sliding it under the anode cap.
  - d. Wait two minutes and repeat step c.
5. Disconnect the harness connectors from the video display.
6. Remove the motor amplifier assembly from the cabinet side.
7. Remove the four screws and washers that hold the video display on the shelf.
8. Pull the video display out of the back of the cabinet.

### WARNING

*When you take the video display out of the cabinet, do not drop it! The display is heavy. Be careful!*

*Wear gloves to protect your hands from the sheet-metal edges.*

9. Replace the video display as described in the following procedure.

## Replacing the Video Display

Perform the following procedure to replace the video display in the cabinet. (See Figure 3-16.)

### NOTE

*Before you replace the display in the simulator, clean the screen and the inside of the shield. Carbon particles from the motor collect on the surfaces and obscure the view.*

1. Carefully lift the video display onto the display shelf in the cabinet.

### NOTE

*When you replace the cathode-ray tube and yoke together, adjust the brightness, size, and centering as described in the video display service manual.*

*Check the purity and convergence according to the service manual instructions, but adjust both only if required.*

2. Position the display so that the four holes in the video display mounting brackets line up with the four holes in the video display shelf.
3. Loosely install the four hex-head screws and washers through the mounting brackets and into the video display shelf.
4. Push the video display forward against the bezel.
5. Be sure that the display is centered horizontally in the bezel. Tighten the screws.
6. Install the motor amplifier assembly on the side of the cabinet.
7. Connect the harness connectors to the video display.
8. Replace the large and small top service panels.

**Table 3-11 Troubleshooting the Video Display**

| Problem                                | Solution  |
|--|---|
| Any problem.                           | Determine if the problem is with the display or the simulator hardware by performing the self-test. If you cannot perform the self-test, use the DIP switch diagnostics to narrow down the source of the problem. |
| Convergence, purity or color problems. | Check the voltage level to the video display PCB.<br>Check the video display settings with the Monitor Test Screens in the self-test.   |

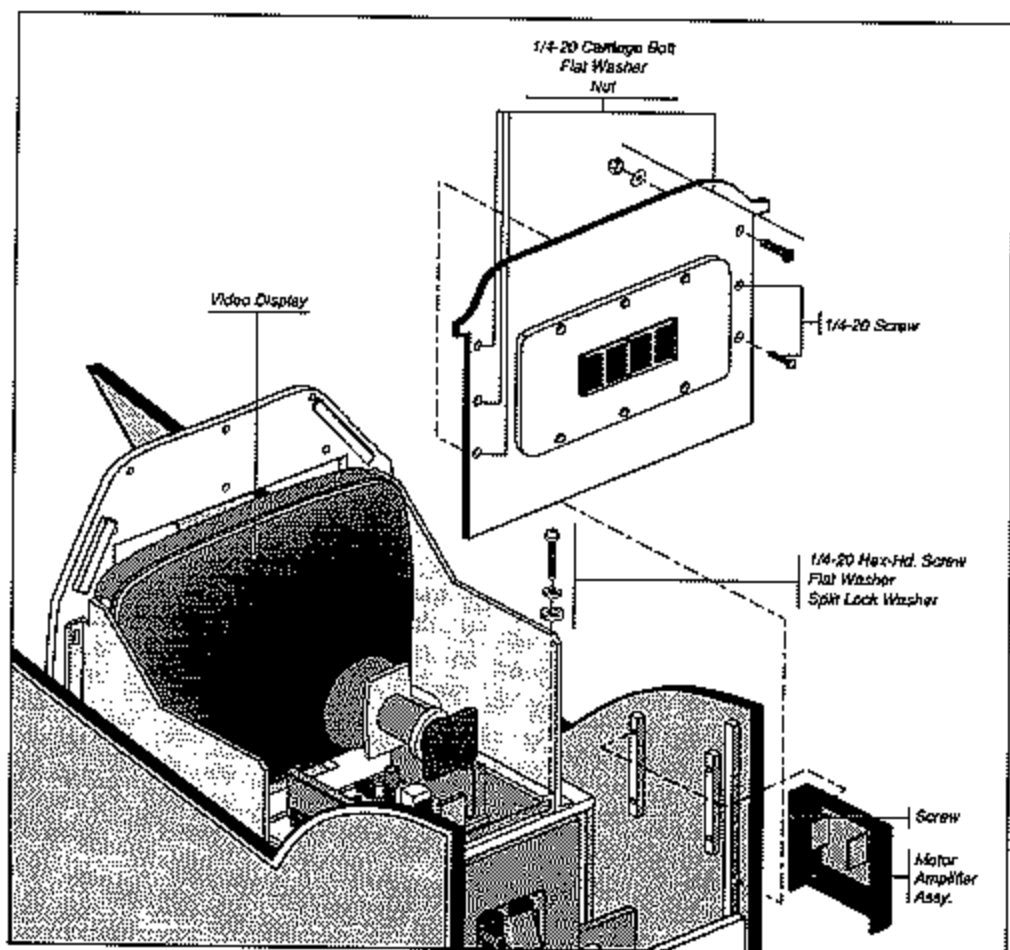


Figure 3-17 Removing the Video Display

## Motor Amplifier Assembly

### Removing the Motor Amplifier Assembly

1. Turn the simulator power off, but leave the power cord plugged in. Wait two minutes.

#### **WARNING**

The PCBs in this assembly contain lethal high voltages. To avoid injury, do not remove the assembly until you observe all precautions necessary for working on high-voltage equipment.

2. Unplug the power cord.
3. Take off the harness to the PC boards.
4. Remove the entire assembly from the cabinet. Do not remove the PC boards from the heat sink.
5. Send the entire assembly back to your distributor for trade-in.

## Speakers

If you have problems with a speaker, check Table 3-12, *Troubleshooting the Speakers*, before you replace it.

### Removing a Speaker

1. Turn the simulator power off.
2. Remove the dashboard, following the directions in the section *Removing the Dashboard*.

**Table 3-12 Troubleshooting the Speakers**

| Problem  | Solution   |
|----------|--|
| No sound | <p>Make sure the volume is turned up.</p> <p>If the volume is turned up, do the following:</p> <p>Do the self-test to make sure you do not have a sound PCB problem.</p> <p>Check the voltage level to the sound PCB.</p> <p>Check the wiring.</p> <p>Replace the speaker if defective.</p> <p>If none of the above work, the problem may be on the APU PCB or the main PCB.</p> |

**CAUTION**

*Be careful when handling the speaker. The cone material is fragile and can be easily damaged.*

- Remove and replace the speaker.
- Install the dashboard, following the directions in the section *Installing the Dashboard*.

## PC Board Stack

### Removing a Board from the PC Board Stack

Four PC boards are stacked in the following order (top to bottom) as illustrated in Figure 3-18:

- the Sound PC board
- the DSK PC board
- the ADSP II PC board
- the Main PC board

The boards are attached at the corners. *Some of the standoffs are permanently attached to the corners; do not try to remove them.*

- Turn the power off and remove the bottom service door at the back of the simulator.
- Remove the board stack from the simulator.
- Remove the four 2-1/2 inch screws from the corners of the Sound PC board on the top of the stack.
- Disconnect the harness and all ribbon cables.
- The DSK PC board is a short board attached below the Sound PC board. To detach the DSK PC board, remove the two 3/8 inch screws from the top center of the Sound PC board.

## Replacing Static-Sensitive Devices

Be careful when you work with static-sensitive devices on the simulator PCBs. These devices can be microprocessors, field-effect transistors (FET), complementary metal-oxide semiconductors (CMOS), and other large-scale integration (LSI) devices that use metal-oxide semiconductor (MOS) technology.

These devices can fail from a static charge that has built up in your body. They can also fail because of leakage from an improperly grounded soldering iron.

Before you handle a static-sensitive device or a PCB with such devices attached to it, ground any static voltage that may have accumulated in your body by touching an object that is earth-grounded. If you solder a static-sensitive device, use a soldering iron with a properly grounded three-wire cord.

Before you replace a static-sensitive device, make sure that the device actually is defective. A static-sensitive device can appear defective due to leakage on a PCB. To check if a device is defective, ground any static voltages as described in the paragraph above. Clean both sides of the PCB with flux remover or an eraser. For discrete FETs, clean thoroughly between the gate, drain, and source leads. Then test the device.

A new static sensitive device may be packaged in conductive foam or may have a protective shorting wire attached to the pins. Remove the conductive foam just prior to inserting the device into its socket or soldering it to a PCB. Remove the shorting wire only after the device is inserted into its socket or after all the leads are soldered in place.



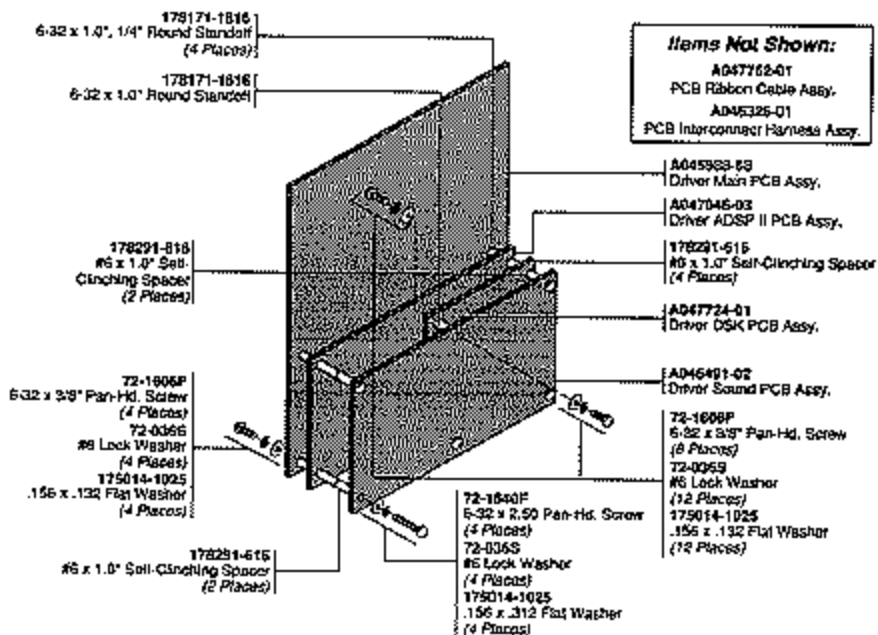


Figure 3-18 Disassembling the PC Board Stack

## Cleaning the Coin Mechanism

Use a soft-bristled brush to remove loose dust or foreign material from the coin mechanism. Use a toothbrush to remove any stubborn build-up of residue in the coin path. After cleaning the coin mechanism, blow out the dust with compressed air.

## Cleaning the Interior Components

Perform the following procedure to clean the components inside the cabinet.

1. Open the small top service panel and bottom service door.
2. Discharge the high voltage from the cathode-ray tube (CRT) before proceeding. The display assembly contains a circuit for discharging the high voltage to ground when power is removed. However, to make certain, always discharge the display as follows:

### WARNING

Turn off the AC power, but do not unplug the power cord before cleaning inside the cabinet. The power cord provides a ground path for stray static voltages that can be present on the cleaning tools.

- a. Attach one end of a solid gauge wire to a well-insulated screwdriver or wooden handle.
  - b. Attach the other end of the wire to an earth ground.
  - c. Quickly touch the blade end of the screwdriver to the CRT anode by sliding it under the anode cap.
  - d. Wait two minutes and repeat part c.
3. Use a vacuum cleaner with a soft long-bristled brush attachment or use a soft-bristled paint brush to remove loose dirt and dust accumulated on the inside of the cabinet. Be sure to clean the power supply, PCB assemblies, and video display thoroughly.

### CAUTION

Be extremely careful when cleaning the electrical components inside the cabinet. Do not touch the electrical components with any solid object other than the soft bristles of the vacuum attachment or paint brush.

# N O T E S





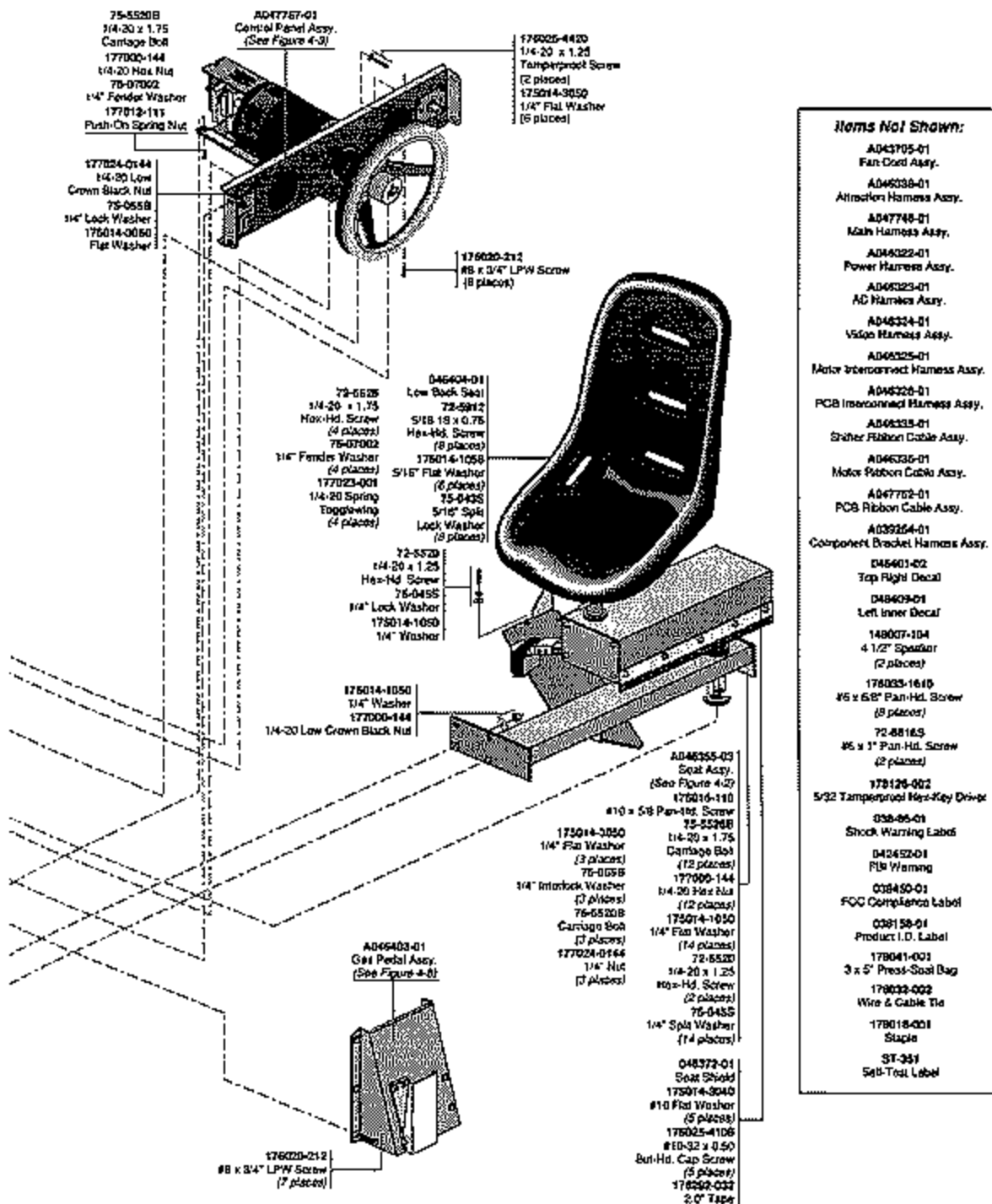


Figure 4-1 Cabinet-Mounted Assemblies, Front View, Continued  
A046250-01 E

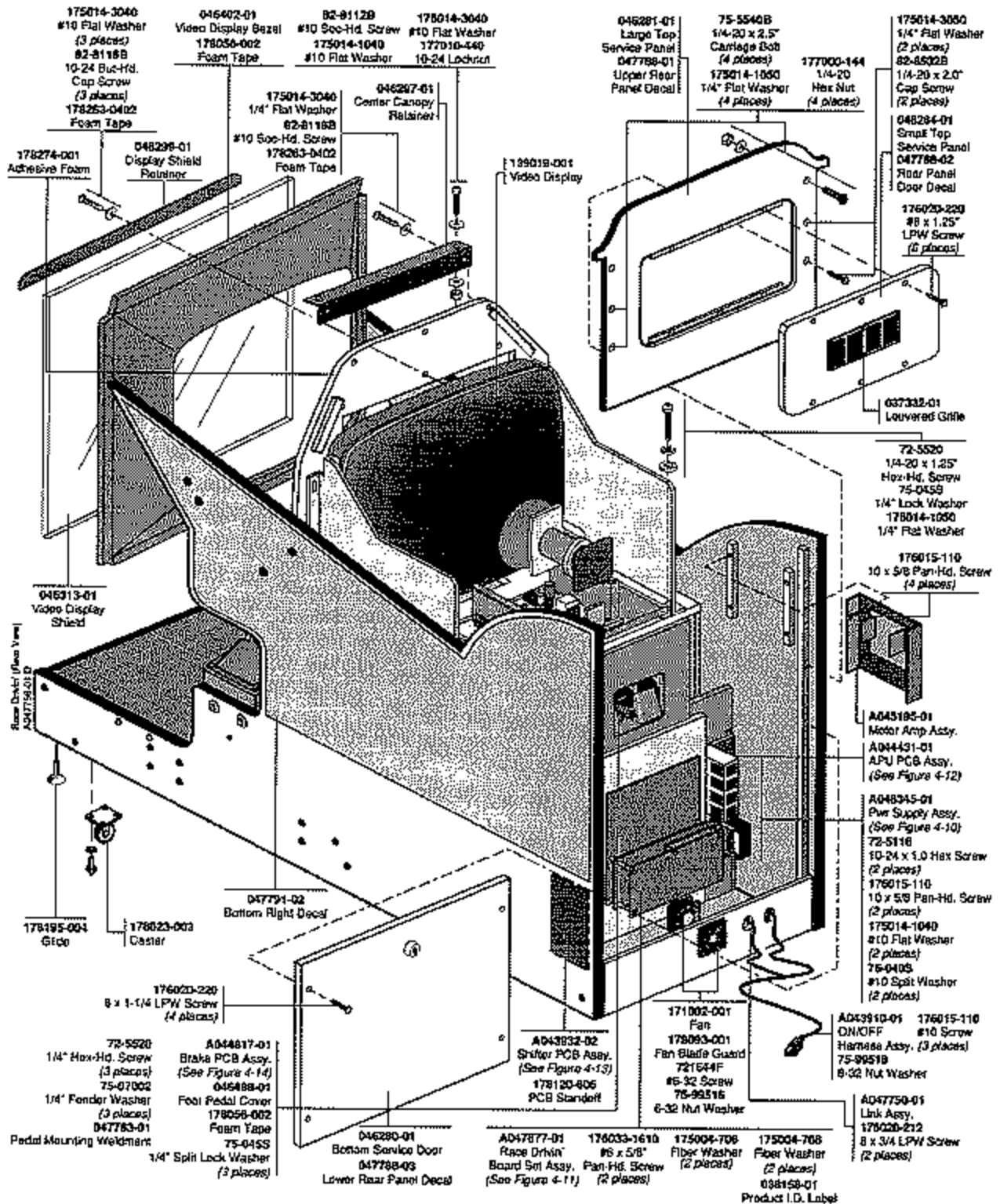


Figure 4-1 Cabinet-Mounted Assemblies, Rear View  
A046250-01 E

## Cabinet-Mounted Assemblies Parts List

| Part No.   | Description   | Part No.    | Description   |
|------------|---|-------------|---|
| A043705-01 | 12-Inch Fan Cord Assembly   | 175014-1040 | #10 Washer  |
| A043910-01 | On/Off Harness Assembly   | 75-99511    | #10-24 Nut/Washer Assembly                                    |
| A043932-02 | Shifter PCB Assembly (See Figure 4-13)                                      | 82-81088    | #10-24 x 1/2-Inch Butt-Hd. Blk Screw                          |
| A044431-01 | APU PCB Assembly (mounted on Power Supply Assembly) (See Figure 4-12)       | A047760-01  | Cabinet Assembly  |
| A044817-01 | Brake PCB Assembly (mounted on Clutch and Brake Assembly) (See Figure 4-14) | A047796-01  | Shifter Assembly (See Figure 6-6)                             |
| A045195-01 | Motor Amplifier Assembly  | 038086-01   | Shock Warning Label   |
| A045988-08 | Race Drivin' Main PCB Assembly* (See Figure 4-11)                           | 038091-01   | Cash Box  |
| A046251-01 | Shipping Container Assembly   | 046255-01   | Coin Box Shroud   |
| A046253-01 | Coin Box Assembly   | 046278-01   | Front Floor Panel <sup>3</sup> (for Seat Assembly A046355-01) |
| A046349-01 | Program Plug Assembly   | 046280-01   | Bottom Service Door   |
| A046322-01 | Power Harness Assembly  | 046281-01   | Large Top Service Panel                                       |
| A046323-01 | AC Harness Assembly   | 046284-01   | Small Top Service Panel                                       |
| A046324-01 | Video Harness Assembly  | 046294-01   | Floor Trim  |
| A046325-01 | Motor Interconnect Harness Assembly   | 046296-01   | Front Canopy Support  |
| A046326-01 | PCB Interconnect Harness Assembly   | 046297-01   | Center Canopy Retainer  |
| A046335-01 | Ribbon Cable Assembly to the Shifter  | 046299-01   | Display Shield Retainer                                       |
| A046336-01 | Ribbon Cable Assembly to the Motor  | 046313-01   | Monitor Shield  |
| A047752-01 | Ribbon Cable Assembly to the PCBs   | 046316-01   | Under-Dash Cover  |
| A046340-01 | Component Bracket Assembly:   | 046372-01   | Seat Shield   |
| A039254-01 | Component Bracket Harness Assy.   | 046390-02   | Bumper Pad  |
| A046341-01 | Coin Counter Assembly   | 046401-01   | Top Left Decal  |
| 119006-103 | 10K $\Omega$ Potentiometer Audio Taper                                      | 046401-02   | Top Right Decal   |
| 160034-241 | Slide Switch  | 046402-01   | Video Display Bezel   |
| 160049-001 | Push-Button Switch  | 046404-01   | Low Back Seat   |
| A046345-01 | Power Supply Assembly (See Figure 4-10)                                     | 046415-01   | Hole Cover Plate  |
| A046355-XX | Seat Assembly* (See Figure 4-2)   | 046498-01   | Foot Pedals Cover   |
| A046380-01 | Clutch And Brake Pedal Assembly (See Figure 4-7)                            | 047049-01   | Front Floor Panel <sup>3</sup> (for Seat Assembly A046355-03) |
| A046403-01 | Gas Pedal Assembly (See Figure 4-8)   | 047772-01   | Right Canopy  |
| A046491-02 | Sound PCB Assembly  | 047773-01   | Left Canopy   |
| A047046-03 | ADSP II PCB Assembly  | 047774-01   | Top Canopy  |
| A047724-01 | DSK PCB Assembly  | 047783-01   | Pedal Mounting  |
| A047746-01 | Main Harness Assembly   | 047788-01   | Upper Rear Panels Decal                                       |
| A047750-01 | Link Assembly   | 047788-02   | Rear Door Panels Decal  |
| A047749-01 | Link Harness Assembly   | 047788-03   | Lower Rear Panels Decal                                       |
| 047779-01  | Link Plate  | 047789-01   | Number Plate Decal  |
| 178305-001 | Jackscrew Kit   | 047790-01   | Left Inner Decal  |
| A047757-01 | Control Panel Assembly (See Figure 4-3)                                     | 047790-02   | Right Inner Decal   |
| A047758-01 | Attraction Assembly. Replaceable Parts:                                     | 047791-01   | Bottom Left Decal   |
| A047761-01 | Attraction Sign Sub-Assembly  | 047791-02   | Bottom Right Decal  |
| A046338-01 | Attraction Harness Assembly   | 047791-03   | Left Canopy Decal   |
| 047793-01  | Attraction Decal  | 047791-04   | Right Canopy Decal  |
| 047780-01  | Attraction Shield   | 047873-01   | Shift Mounting Plate  |
| 046308-01  | Attraction Cover  | 139019-001  | 25-Inch Framed Color Raster, Medium Resolution Video Display  |
| 047778-01  | Attraction Frame  | 148007-104  | 4 1/2-Inch Diameter, 8 $\Omega$ , 10W Shielded Speaker        |
| 047781-01  | Attraction Retainer   | 171002-001  | Exhaust Fan   |
| 170003-001 | 18-Inch, 15 Watt Fluorescent Light  | 171027-001  | Coin Door (See Figure 4-9)                                    |
| 171086-001 | 18-Inch Fluorescent Lamp Fixture  | 175004-706  | .154 I.D., .375 O.D. Fiber Washer                             |
| 178052-002 | #10 Screw Tie   | 175004-708  | .190 I.D., .640 O.D. Fiber Washer                             |
| 178232-001 | Fluorescent Lamp Retaining Clip   | 175014-1040 | .218 x .500 x .050 Flat Zinc Washer                           |
|            |   | 175014-1050 | .218 x .625 x .065 Flat Zinc Washer                           |

Note: For the details of all the parts of the Race Drivin' Board Set Assembly (part no. A047877-01), see Figure 3-18.

## Cabinet-Mounted Assemblies Parts List

| Part No.    | Description                                | Part No.   | Description   |
|-------------|--|------------|---|
| 175014-1056 | .344 x .688 x .065 Flat Zinc Washer        | 72-1650F   | 6-32 x 3.125 X-Rec Pan-Head Screw   |
| 175014-3040 | .218 x .500 x .050 Flat Black Washer       | 72-5116    | #10-24 x 1.0" Hex Head Screw  |
| 175014-3050 | .218 x .625 x .065 Flat Black Washer       | 72-5520    | 1/4-20 x 1 1/4 Hex Head Screw   |
| 176015-110  | #10 x 5/8-Inch Pan Head Tapping Screw      | 72-5528    | 1/4-20 x 1.75" Inch Hex Head Screw  |
| 176019-228  | #8 x 1 3/4-Inch Black LPW Screw            | 178023-001 | 1/4-20 x 2.0 Hex Screw  |
| 176020-208  | #8 x 1/2-Inch Black Phillips-LPW Screw     | 72-5912    | 5/16-18 x 3/4 Inch Hex Head Screw   |
| 176020-212  | #8 x 3/4-Inch Black Phillips-LPW Screw     | 72-6616S   | #6 x 1-Inch Pan-Head X-Rec Screw  |
| 176020-220  | #8 x 1 1/4-Inch Black Phillips-LPW Screw   | 75-040S    | #10 Steel Split-Lock Washer   |
| 176025-4420 | 1/4-20 x 1.25 Black Tamperproof Screw      | 75-043S    | 5/16 Steel Split-Lock Washer  |
| 176025-4108 | #10-32 x 1/2-Inch Black Tamperproof Screw  | 75-045S    | 1/4 Steel Split-Lock Washer   |
| 176025-4420 | 1/4-20 x 1.25 Button Cap Tamperproof Screw | 75-055B    | 1/4 Steel Black Oxide lock Washer   |
| 176033-1610 | #6 x 5/8-Inch Phillips-Pan-Head Screw      | 75-5520B   | 1/4-20 x 1 1/4-Inch Round Head, Square Neck Black Carriage Bolt                           |
| 177000-144  | 1/4-20 Hex Nut                             | 75-5524B   | 1/4-20 x 1 1/2-Inch Round Head, Square Neck Black Carriage Bolt                           |
| 177010-244  | 1/4-20 Polymer Locknut                     | 75-5528B   | 1/4-20 x 1 3/4-Inch Round Head, Square Neck Black Carriage Bolt                           |
| 177010-440  | #10-24 Polymer Locknut                     | 75-5540B   | 1/4-20 x 2 1/2-Inch Black Carriage Bolt   |
| 177012-111  | Push On Spring Nut                         | 75-07002   | 1/4 Fender Washer   |
| 177023-001  | 1/4-20 Togglewing Spring                   | 75-99516   | #6-32 Nut/Washer Assembly   |
| 177024-0144 | 1/4-20 Low Crown Nut                       | 75-99518   | #8-32 Nut/Washer Assembly   |
| 178018-001  | 1/2 x 5/8 Staple                           | 78-13011   | Bonding Agent   |
| 178032-002  | #10 Screw Hole Tie, Wire & Cable           | 82-8112B   | #10-24 x 5/8-Inch Black Hex Socket Button-Head Screw                                      |
| 178041-001  | 3 x 5-Inch Press-seal Bag                  | 82-8116B   | #10-24 x 1-Inch Black Hex Socket Button-Head Screw  |
| 178056-002  | 1/2-Inch Wide Foam Tape                    | 82-8524    | 1/4-20 x 1 1/2-Inch Black Button-Head Screw   |
| 178093-001  | Fan Blade Guard                            | 82-8532B   | 1/4-20 x 2-Inch Black Button-Head Screw   |
| 178120-606  | PCB Standoff                               |            |   |
| 178126-002  | Tamperproof Hex Key Driver                 |            |   |
| 178254-016  | Double-Coated Acrylic Foam Tape            |            |   |
| 178257-004  | Black Square Finish Plug                   |            |   |
| 178265-0402 | 1/4-Inch Wide Foam Tape                    |            |   |
| 178274-001  | Black Adhesive Back Foam                   |            |   |
| 178292-032  | 2-Inch Safety-Hazard Reflective Tape       |            |   |
|             |  |            | <i>Documentation for the Race Drivin' simulator:</i>                                      |
|             |  | SP-351     | Race Drivin' Schematic Package  |
|             |  | ST-351     | Race Drivin' Self-Test Label  |
|             |  | TM-295     | Wells-Gardner 25-Inch, Medium-Resolution Color Display Service Manual (for Model 25K5515) |
|             |  | TM-351     | Race Drivin' Operator's Manual  |

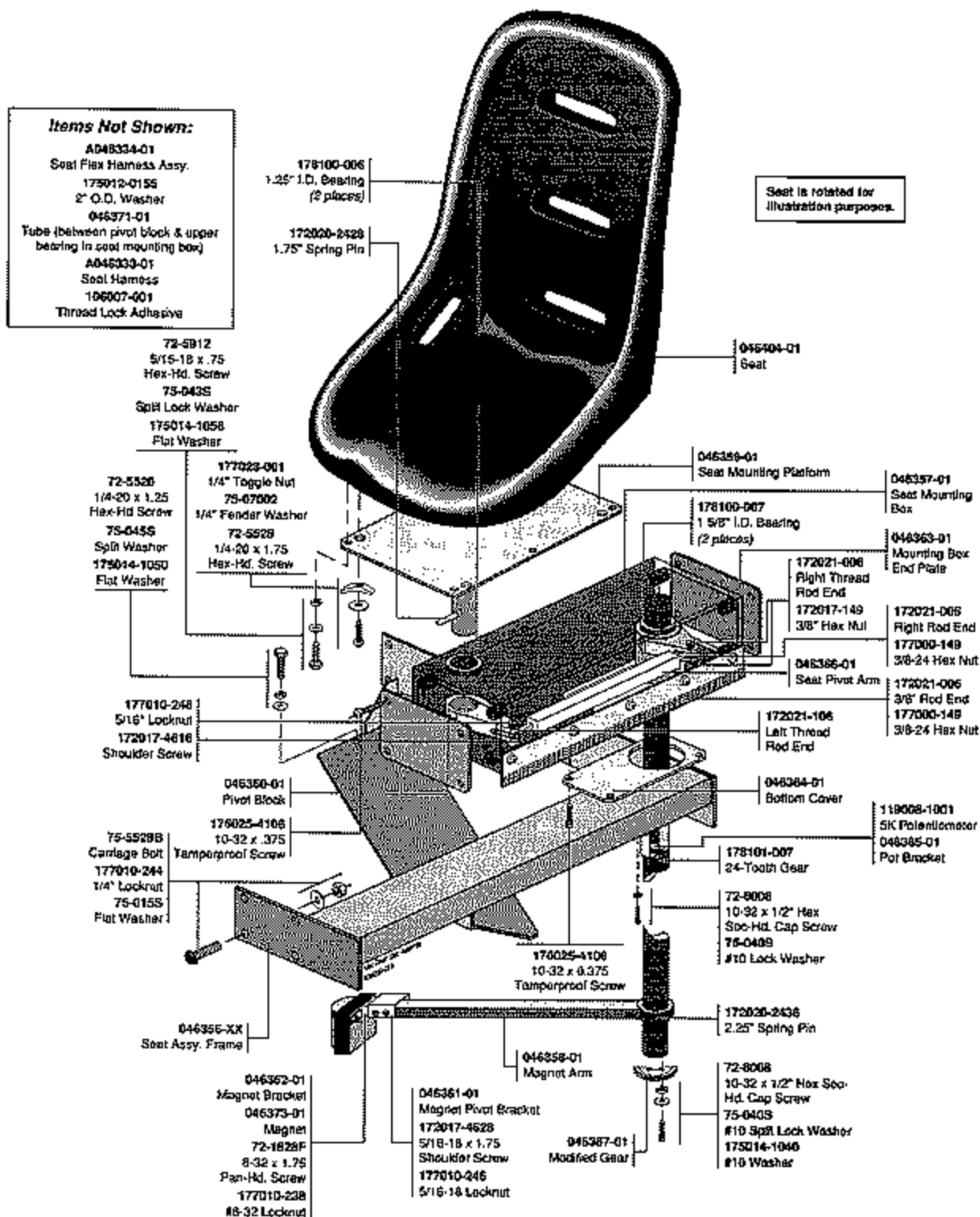
- <sup>1</sup> A045988-01 is the U.S. version.  
A045988-02 is the German version.  
A045988-03 is the right-hand-drive British version.

- <sup>2</sup> A046355-01 is the seat assembly with a 1/4-inch metal plate that is bolted to the left side of the cabinet (as shown in Figure 4-2).  
A046355-03 is the seat assembly without a 1/4-inch metal plate that is bolted to the left side of the cabinet.  
A046355-03 replaces A046355-01.

- <sup>3</sup> Front floor panel 046278-01 goes with the seat assembly A046355-01. It has the cutout for the metal plate on the seat assembly that is bolted to the left side of the cabinet.  
Front floor panel 047049-01 goes with the seat assembly A046355-03. However, the seat assembly A046355-03 can use the front floor panel 046278-01 if it is already installed.



# N O T E S



Seat is rotated for illustration purposes.

Figure 4-2 Seat Assembly  
A046355-XX<sup>1</sup> E

### Seat Assembly Parts List

| Part No.    | Description                                      | Part No.    | Description   |
|-------------|--|-------------|---|
| A046333-01  | Seat Harness Assembly                            | 172017-4628 | 5/16-18 x 1.75-Inch Long Socket-Head Shoulder Screw |
| A046334-01  | Seat Flex Harness Assembly                       | 172020-2428 | 5/16-18 x 1.75-Inch Slotted Spring Pin              |
| 046356-02   | Metal Seat Frame                                 | 172020-2436 | .375-Inch Diameter x 2.25-Inch Slotted Spring Pin   |
| 046357-01   | Seat Mounting Box                                | 172021-006  | 3/8-24 Rod End—Right Hand Thread                    |
| 046358-01   | Magnet Arm                                       | 172021-106  | 3/8-24 Rod End—Left Hand Thread                     |
| 046359-XX   | Seat Mounting Platform <sup>2</sup>              | 175012-0155 | 1.25-Inch I.D. Washer                               |
| 046360-01   | Seat Pivot                                       | 175014-1032 | #8 Flat Washerr                                     |
| 046361-01   | Magnet Pivot Bracket                             | 175014-1040 | #10 Flat Washer                                     |
| 046362-01   | Magnet Bracket                                   | 176025-4106 | #10-32 x 3/8-Inch Tamperproof Screw                 |
| 046363-01   | Mounting Box End Plate                           | 177000-149  | 3/8-24 Hex Nut                                      |
| 046364-01   | Bottom Cover for Mounting Box                    | 177010-238  | #8-32 Polymer Locknut                               |
| 046365-01   | Potentiometer Bracket                            | 177010-246  | 5/16-18 Polymer Lock Nut                            |
| 046366-01   | Seat Pivot Arm                                   | 178032-002  | #10 Tie, Wire & Cable Screw Hole                    |
| 046367-01   | Modified Gear                                    | 178065-100  | 4-Inch Tie, Wire & Cable                            |
| 046370-01   | Seat Support                                     | 178068-002  | 1-Inch Cable Tie Mount                              |
| 046371-01   | Tube   | 178101-007  | 24-Tooth Spur Gear                                  |
| 046373-01   | Magnet   | 72-1828F    | #8-32 x 1 3/4-Inch Pan-Head Screw                   |
| 046404-01   | Seat   | 72-8008     | #10-32 x 1/2-Inch Socket-Head Cap Screw             |
| 047795-01   | Hose Clamp                                       | 75-040S     | #10 Split Lock Washer                               |
| 106007-001  | Adhesive, Threadlock                             |             |   |
| 119008-1001 | 5 KΩ Potentiometer                               |             |   |
| 172017-4616 | 5/16-18 x 1-Inch Long Socket-Head Shoulder Screw |             |   |

<sup>1</sup> A046355-01 is the seat assembly with 046359-01, the seat mounting platform, which has a 1/4-inch vertical metal plate that is bolted to the left side of the cabinet (as shown in Figure 4-2).

A046355-03 is the seat assembly with 046359-03, the seat mounting platform, without the vertical metal plate on the left side.

A046355-03 replaces A046355-01.

<sup>2</sup> 046359-01 is the seat mounting platform with the 1/4-inch vertical metal plate that is bolted the the left side of the cabinet.

046359-03 is the seat mounting platform without the 1/4-inch vertical metal plate.

046359-03 replaces 046359-01.

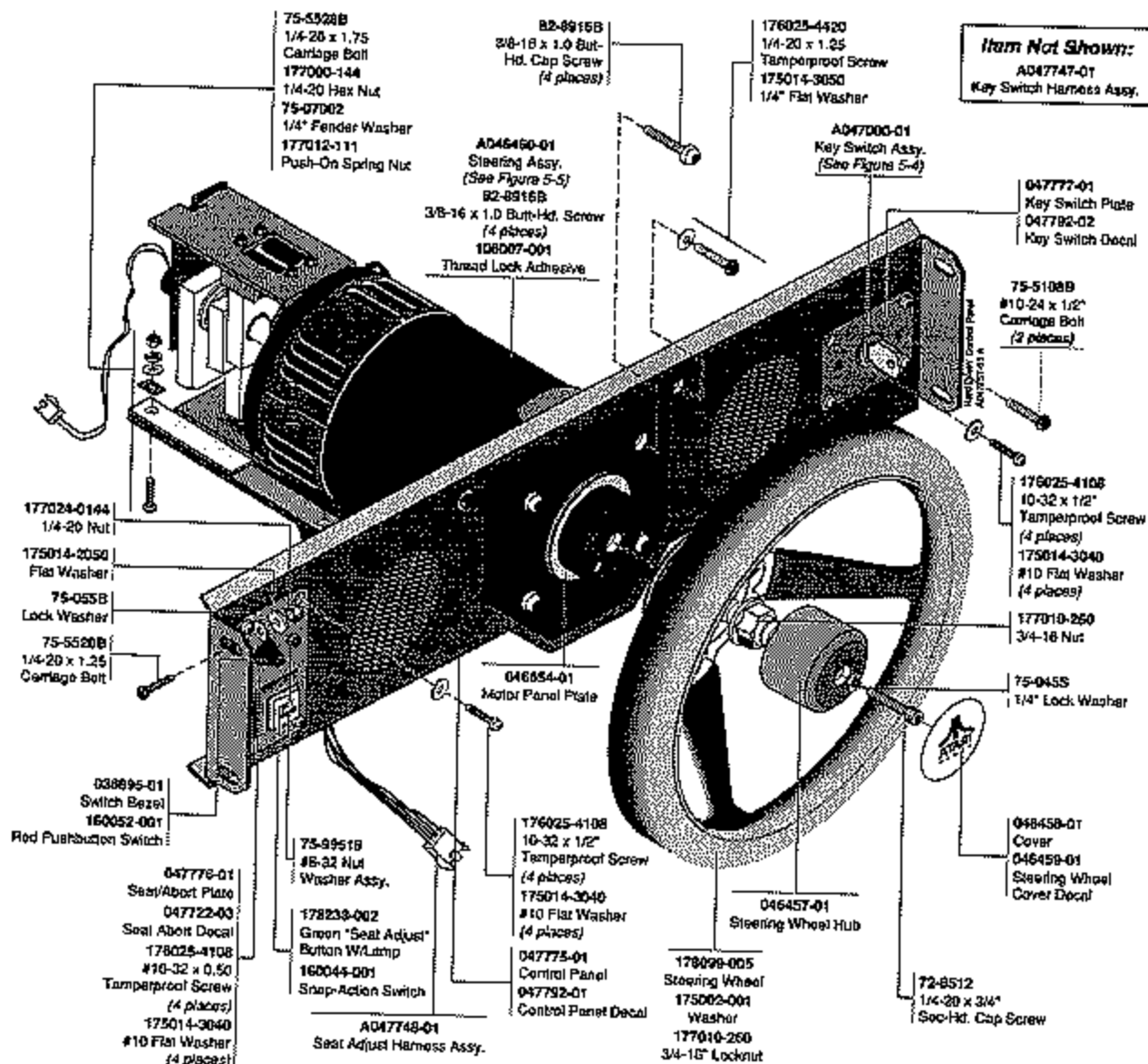
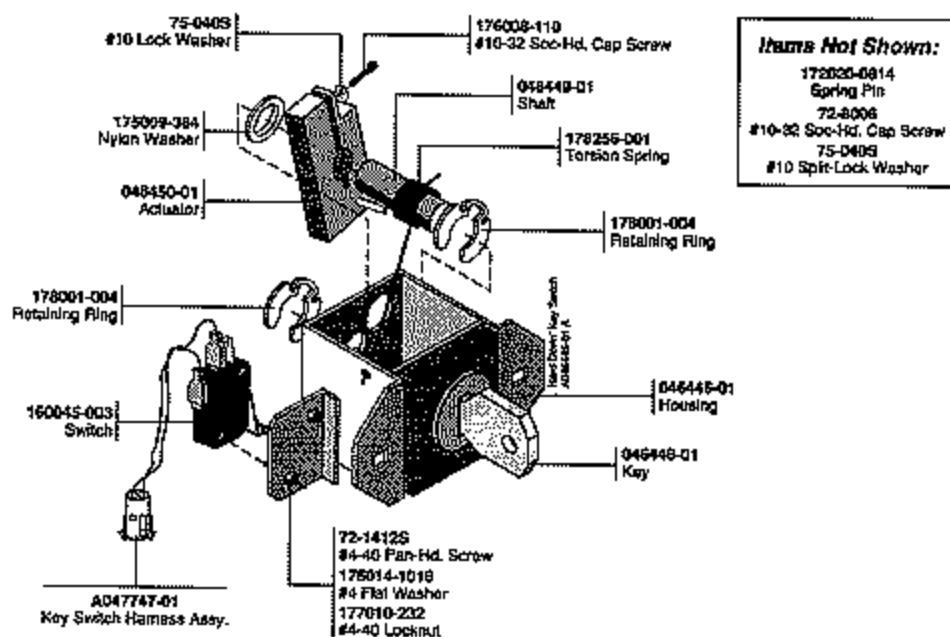


Figure 4-3 Dashboard Assembly  
A047757-01 A

## Dashboard Assembly Parts List

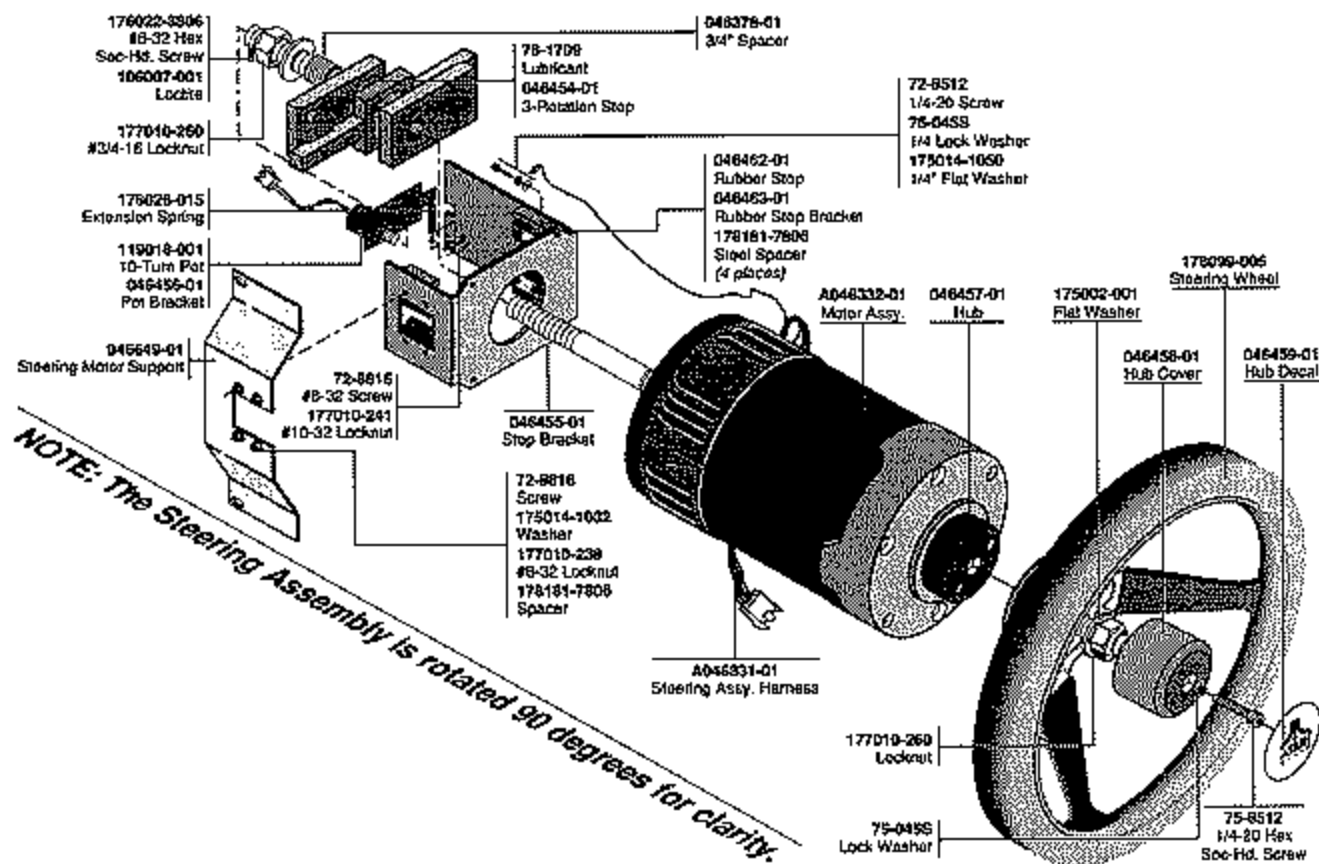
| Part No.   | Description                    | Part No.    | Description                                      |
|------------|--------------------------------|-------------|--|
| A046160-01 | Steering Assembly              | 160044-001  | SPDT Snap-Action Switch                          |
| A047000-01 | Key Switch Assembly            | 160052-001  | Red, Lighted, SPDT Pushbutton Switch             |
| A047747-01 | Key Switch Harness Assembly    | 175002-001  | .750 Shaft Washer                                |
| A047748-01 | Seat Adjust Harness Assembly   | 175014-3040 | #10 .218 x .500 x .050 Flat Black Washer         |
| 036895-01  | Push Button Switch Bezel       | 176025-4108 | #10-32 x 1/2-Inch Button-Head Tamper-Proof Screw |
| 046457-01  | FFB Hub                        | 177010-240  | #10-24 Polymer Locknut                           |
| 046458-01  | Cover                          | 177010-240  | #10-24 Polymer Locknut                           |
| 046459-01  | Decal Cover                    | 177010-260  | 3/4-16 Nyloc Hex Nut                             |
| 046654-01  | Motor Support Plate            | 178099-005  | 12-Inch Deep Dip Steering Wheel                  |
| 047775-01  | Control Panel                  | 178233-002  | 6.3 V "Seat Adjust" Button With Lamp             |
| 047776-01  | Seal/Abort Plate               | 72-8512     | 1/4-20 x 3/4-Inch Socket-Head Cap Screw          |
| 047777-01  | Key Switch Plate               | 75-045S     | 1/4 Split-Lock Washer                            |
| 047792-01  | Control Panel Decal            | 75-5108B    | #10-24 x 1/2-Inch Black Carriage Bolt            |
| 047792-02  | Control Panel Key Switch Decal | 75-99518    | #8-32 Nut/Washer Assembly                        |
| 047793-03  | Control Panel Seal/Abort Decal | 82-8916B    | 3/8-16 x 1-Inch Black Button-Head Cap Screw      |
| 106007-001 | Adhesive, Thread Lock          |             |  |



**Figure 4-4 Key Switch Assembly  
A046445-01 C**

### Key Switch Assembly Parts List

| Part No.    | Description                                | Part No.    | Description                                   |
|-------------|--|-------------|---|
| A047747-01  | Key Switch Harness Assembly                | 175009-364  | Nylon Washer                                  |
| 046448-01   | Key  | 176008-110  | #10-32 x 5/8-Inch Nyloc Socket-Head Cap Screw |
| 046449-01   | Shaft                                      | 177010-232  | #4-40 Locknut                                 |
| 046450-01   | Actuator                                   | 178001-004  | 1/2-Inch Retaining Ring                       |
| 046999-01   | Housing                                    | 178256-001  | Torsion Spring                                |
| 107029-001  | Lithium Grease                             | 72-1412S    | #4-40 x 3/4-Inch Pan-Head Screw               |
| 160045-003  | SPDT Switch                                | 175014-1018 | #4 Flat Washer                                |
| 172020-0814 | 0.125-Inch x 0.875-Inch Slotted Spring Pin | 75-040S     | #10 Split-Lock Washer                         |



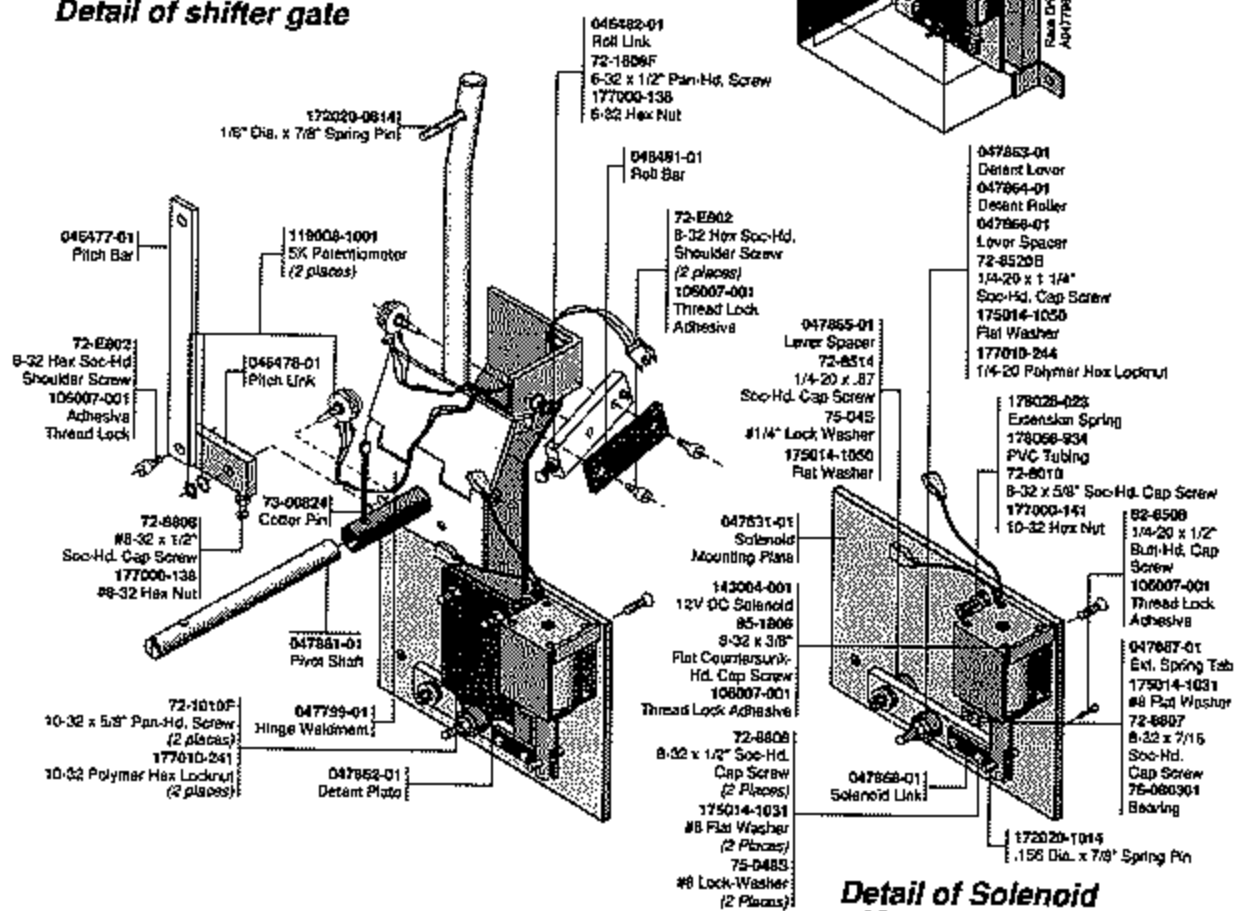
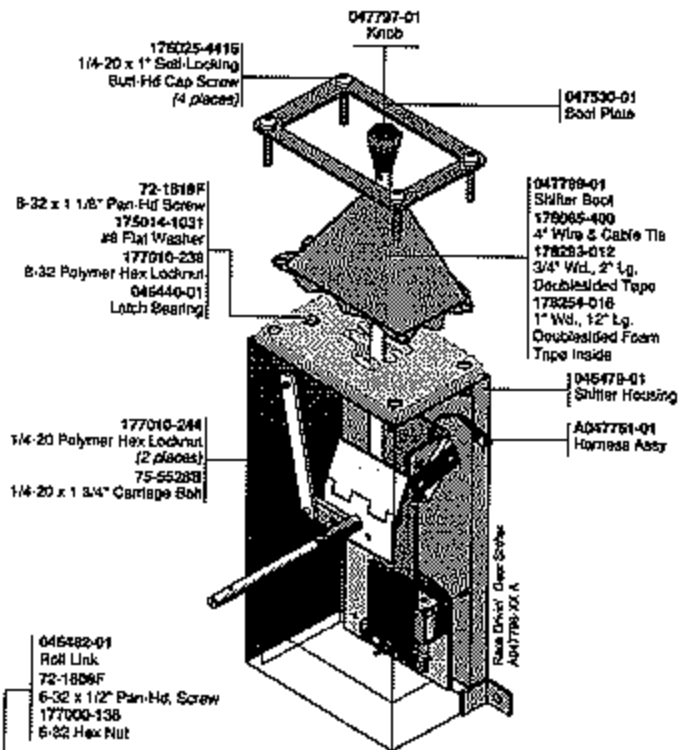
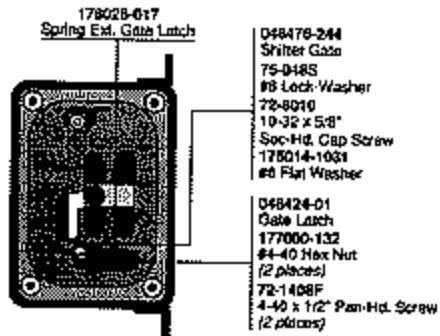
**Figure 4-5 Steering Assembly  
A046460-01 C**



### Steering Assembly Parts List

| Part No.    | Description                                     | Part No.    | Description                                  |
|-------------|---|-------------|--|
| A046331-01  | Steering Assembly Harness                       | 177010-238  | #8-32 Locknut                                |
| A046332-01  | Motor Assembly                                  | 177010-260  | 3/4-16 Locknut                               |
| 046378-01   | 3/4-Inch Spacer                                 | 177011-260  | 3/4-16 Thin Locknut                          |
| 046454-01   | 3-Rotation Stop                                 | 178026-015  | 3/16-Inch O.D. x 1 3/8-Inch Extension Spring |
| 046455-01   | Stop Bracket                                    | 178065-100  | 4-Inch Wire and Cable Tie                    |
| 046456-01   | Potentiometer Bracket                           | 178099-005  | 12-Inch Steering Wheel                       |
| 046457-01   | Steering Wheel Hub                              | 178181-7806 | 3/8-Inch Long Steel Spacer                   |
| 046458-01   | Hub Cover                                       | 72-8512     | 1/4-20 x 3/4-Inch Hex-Head Cap Screw         |
| 046459-01   | Steering Wheel Hub Decal                        | 176022-3806 | #8-32 x 3/8-Inch Hex-Head Cap Screw          |
| 046462-01   | Rubber Stop                                     | 72-8810     | #8-32 x 5/8-Inch Hex-Head Cap Screw          |
| 046463-01   | Rubber Stop Bracket                             | 72-8816     | #8-32 x 1-Inch Hex-Head Cap Screw            |
| 046649-01   | Gull Wing Support                               | 175014-1050 | 1/4 Flat Washer (for ground wire)            |
| 106007-001  | Adhesive Thread Lock                            | 175014-1032 | #8 Flat Washer                               |
| 119018-001  | 10-Turn Potentiometer                           | 75-0458     | 1/4 Split-Lock Washer                        |
| 175002-001  | 0.750-Inch Flat Shaft Washer                    | 78-1709     | Lubricant                                    |
| 176022-3806 | #8-32 x 3/8-Inch Thread Lock Hex-Head Cap Screw |             |  |


**Items Not Shown:**  
 A047753-01  
 Shifter Jumper Assy  
 72-8808  
 8-32 x 3/8" Soc-Hd. Cap Screw

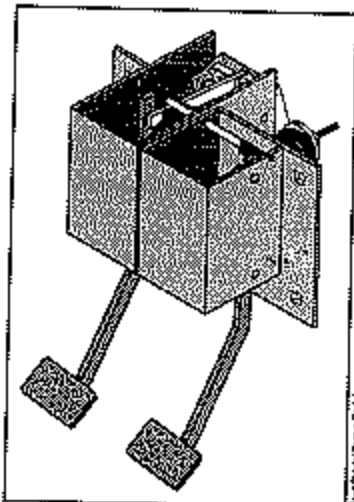


**Figure 4-6 Shifter Assembly  
 A047796-01 A**

### Shifter Assembly Parts List

| Part No.    | Description                                     | Part No.   | Description                                 |
|-------------|---|------------|---|
| A047751-01  | Harness Assembly                                | 177000-138 | #8-32 Hex Nut                               |
| A047753-01  | Shifter Jumper Assembly                         | 177000-141 | #10-32 Hex Nut                              |
| 046424-01   | Reverse Position Latch                          | 177010-238 | #8-32 Polymer Locknut                       |
| 046440-01   | Reverse Position Latch Bearing                  | 177010-241 | #10-32 Polymer Locknut                      |
| 046476-01   | Shifter Gate                                    | 177010-244 | 1/4-20 Polymer Locknut                      |
| 046477-01   | Pitch Bar                                       | 178026-017 | Reverse Position Latch Spring               |
| 046478-01   | Pitch Link                                      | 178026-023 | Extension Spring                            |
| 046479-01   | Shifter Housing                                 | 178065-400 | 4-Inch Black Tie, Wire & Cable              |
| 046481-01   | Roll Bar  | 178066-934 | .375 x 1.75 PVC Tubing                      |
| 046482-01   | Roll Link                                       | 178254-016 | 1-Inch Double-sided Tape                    |
| 047530-01   | Boot Cover Plate                                | 178293-012 | 3/4-Inch Double-Sided Tape                  |
| 047531-01   | Solenoid Plate                                  | 72-1010F   | #10-32 x 5/8-Inch Pan-Head Screw            |
| 047861-01   | Pivot Shaft                                     | 72-1408F   | #4-40 x 1/2-Inch Pan-Head Screw             |
| 047862-01   | Detent Plate                                    | 72-1608F   | #6-32 x 1/2-Inch Pan-Head Screw             |
| 047863-01   | Detent Lever                                    | 72-1818F   | #8-32 x 1 1/8-Inch Pan-Head Screw           |
| 047864-01   | Detent Roller                                   | 72-8010    | #8-32 x 5/8-Inch Socket-Head Cap Screw      |
| 047865-01   | Spacer Lever                                    | 72-8520B   | 1/4-20 x 1 1/4-Inch Socket-Head Cap Screw   |
| 047866-01   | Spacer Roller                                   | 72-8806    | #8-32 x 3/8-Inch Socket-Head Cap Screw      |
| 047867-01   | Extension Spring Tab                            | 72-8807    | #8-32 x 7/16-Inch Socket-Head Cap Screw     |
| 047868-01   | Solenoid Link                                   | 72-8808    | #8-32 x 1/2-Inch Socket-Head Cap Screw      |
| 047797-01   | Knob  | 72-6802    | 0.187 x .125-Inch O.D. Shoulder Screw       |
| 047798-01   | Boot  | 72-8514    | 1/4-20 x 7/8-Inch Socket-Head Cap Screw     |
| 106007-001  | Adhesive Thread Lock                            | 73-00824   | 1/8-Inch Diameter x 1 1/2-Inch Coiler Pin   |
| 119008-1001 | 5 K $\Omega$ Potentiometer                      | 75-0455    | 1/4-Inch Lock Washer                        |
| 143004-001  | Solenoid  | 75-0485    | #8 Lock Washer                              |
| 172020-0814 | 1/8 x 7/8-Inch Spring Pin                       | 75-5528B   | 1/4-20 x 1 3/4-Inch Carriage Bolt           |
| 172020-1014 | .156 x 7/8-Inch Spring Pin                      | 76-080301  | .187 Nyloner Bearing                        |
| 175014-1031 | #8 Flat Washer                                  | 82-8508    | 1/4-20 x 1/2-Inch Button-Head Cap Screw     |
| 175014-1050 | .625 x .27-Inch Flat Washer                     | 85-1806    | 8-32 x 3/8-Inch Flat-Head Countersunk Screw |
| 176025-4416 | 1/4-20 x 1-Inch Self-Locking Butt-Hd. Cap Screw |            |   |
| 177000-132  | #4-40 Hex Nut                                   |            |   |
| 177000-136  | #6-32 Hex Nut                                   |            |   |

 107013-001  
Light Oil  
NOTE: Lubricate on both ends  
of shafts.



Assembled Clutch & Brake

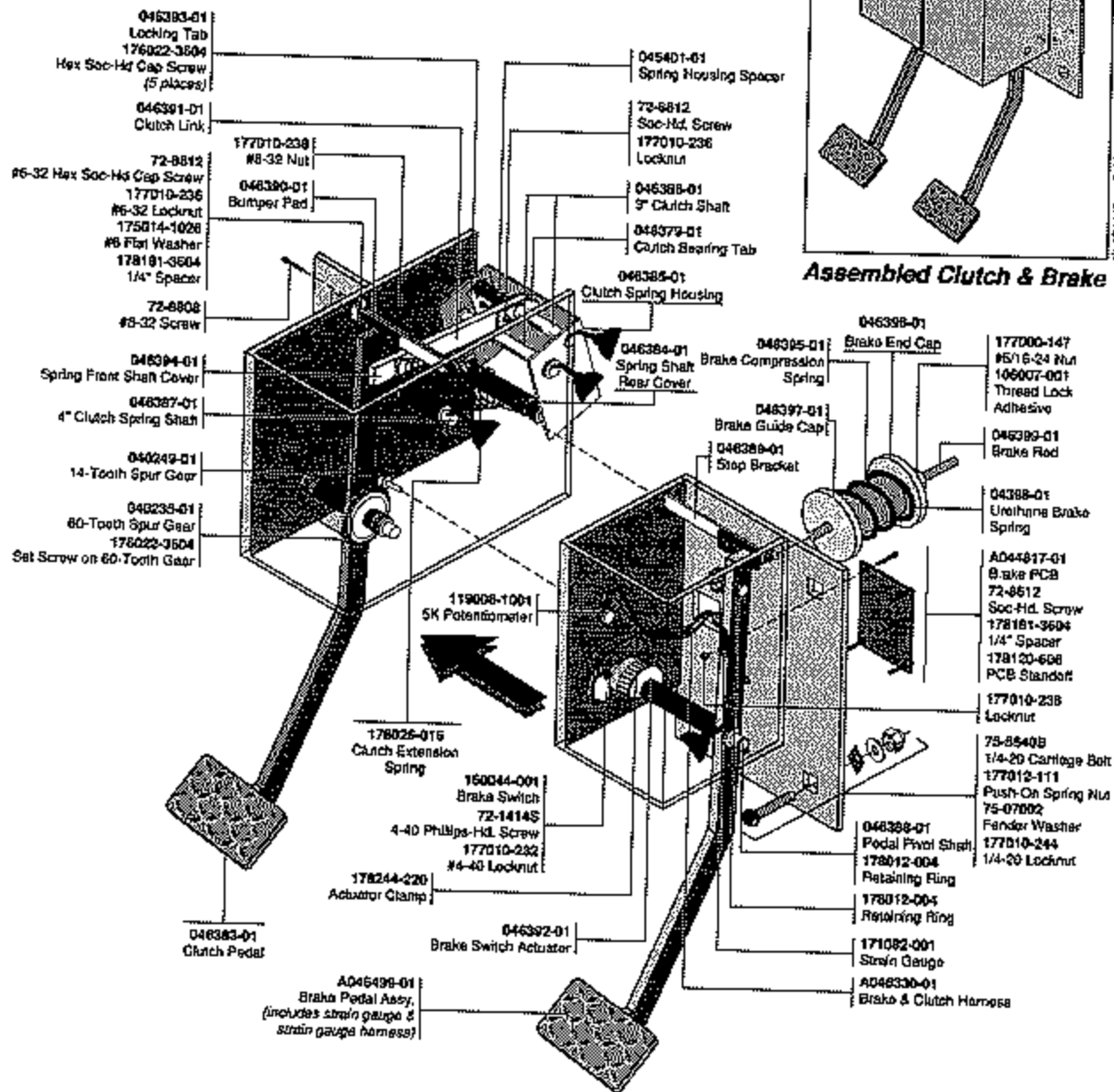
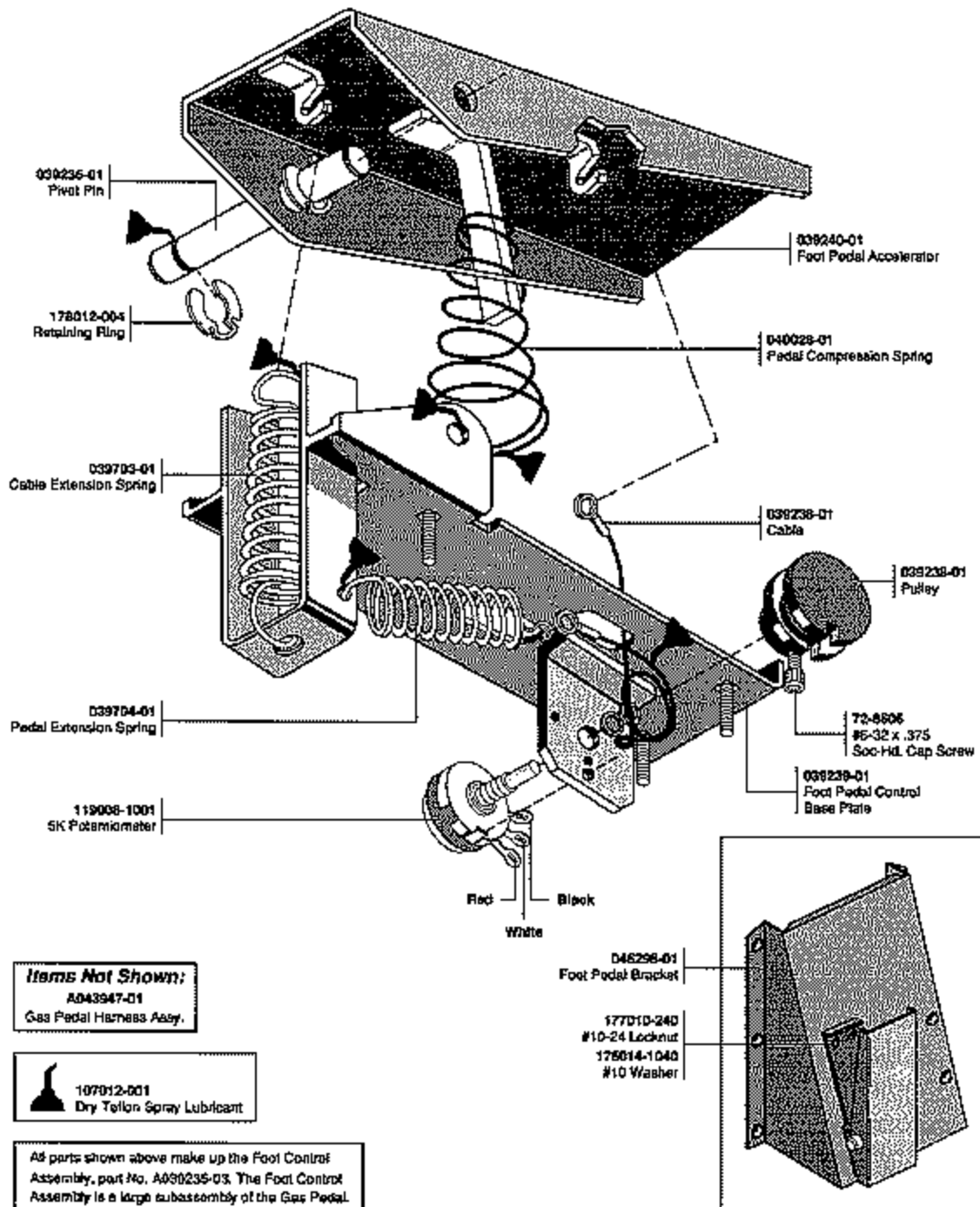


Figure 4-7 Clutch And Brake Pedal Assembly  
A046380-01 E

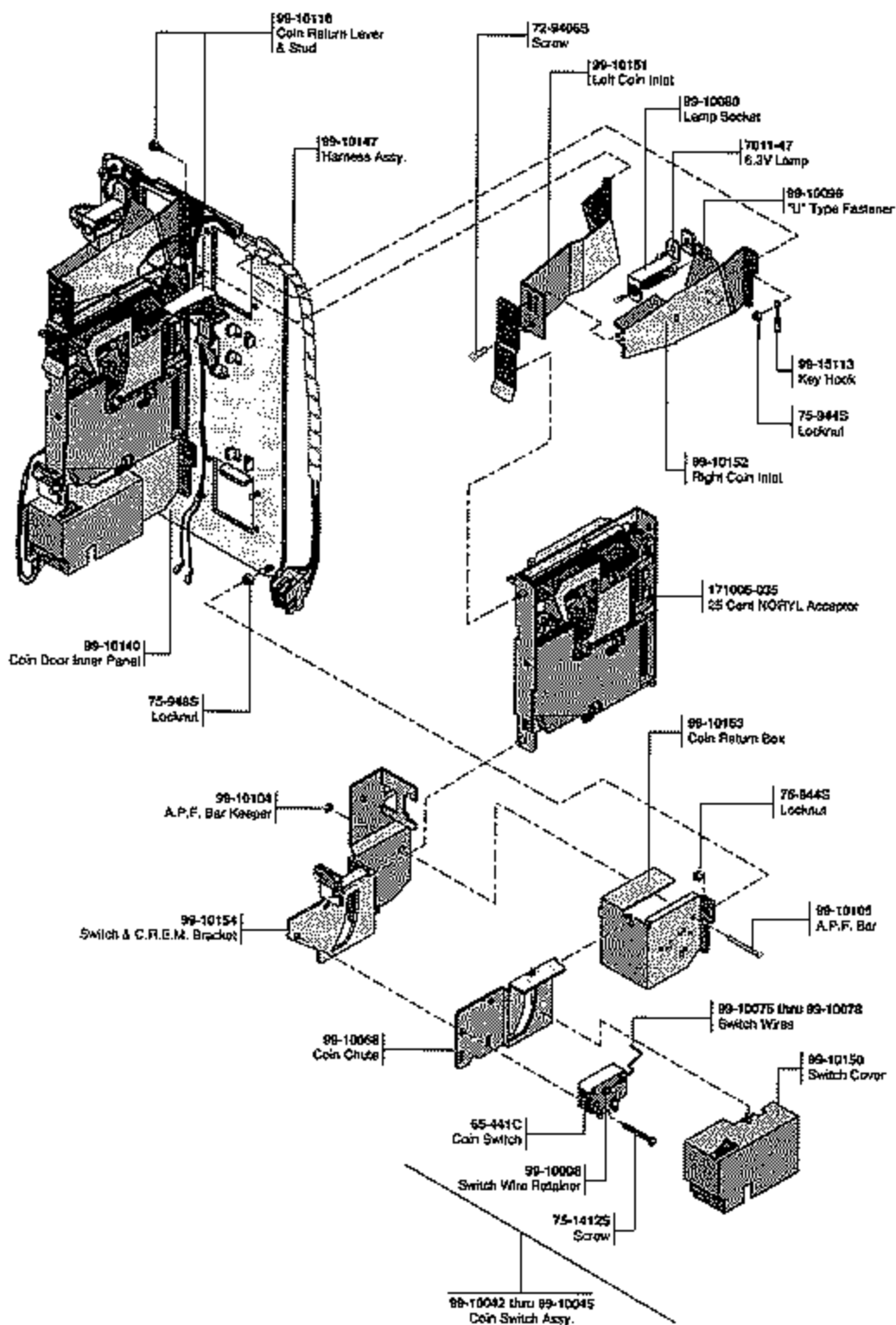




**Figure 4-8 Gas Pedal Assembly  
A046403-01 A**

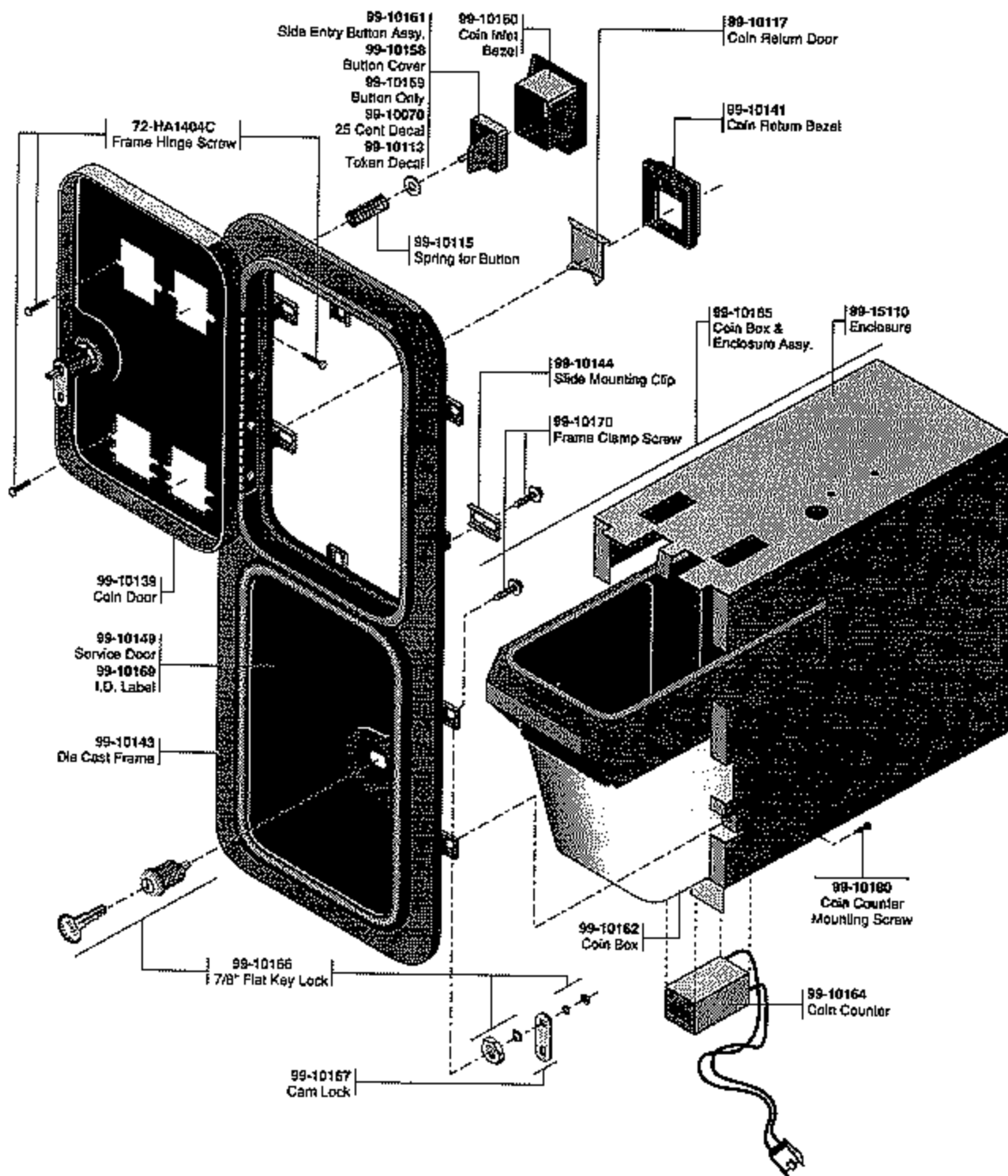
## Gas Pedal Assembly Parts List

| Part No.   | Description                               | Part No.    | Description                                |
|------------|---|-------------|--|
| A039235-03 | Foot Control Assembly. Replaceable Parts: | 107012-001  | Dry Teflon Spray Lubricant                 |
| 039236-01  | Pivot Pin                                 | 178012-004  | Retaining Ring for 3/8-Inch-Diameter Shaft |
| 039238-01  | Pulley                                    | 119008-1001 | 5 K $\Omega$ Potentiometer                 |
| 039239-01  | Foot Pedal Control Base Plate             | 72-8606     | #6-32 x .38-Inch Socket-Head Cap Screw     |
| 039240-01  | Foot Pedal Accelerator                    |             |  |
| 039242-01  | Cable                                     | A043947-01  | Gas Pedal Harness Assembly                 |
| 039703-01  | Cable Extension Spring                    | 046298-01   | Foot Pedal Bracket                         |
| 039704-01  | Pedal Extension Spring                    | 177010-240  | #10-24 Polymer Locknut                     |
| 040028-01  | Pedal Compression Spring                  | 175014-1040 | #10 Flat Washer                            |



**Figure 4-9 Coin Acceptors, Inc. Coin Door Assembly  
171027-001**



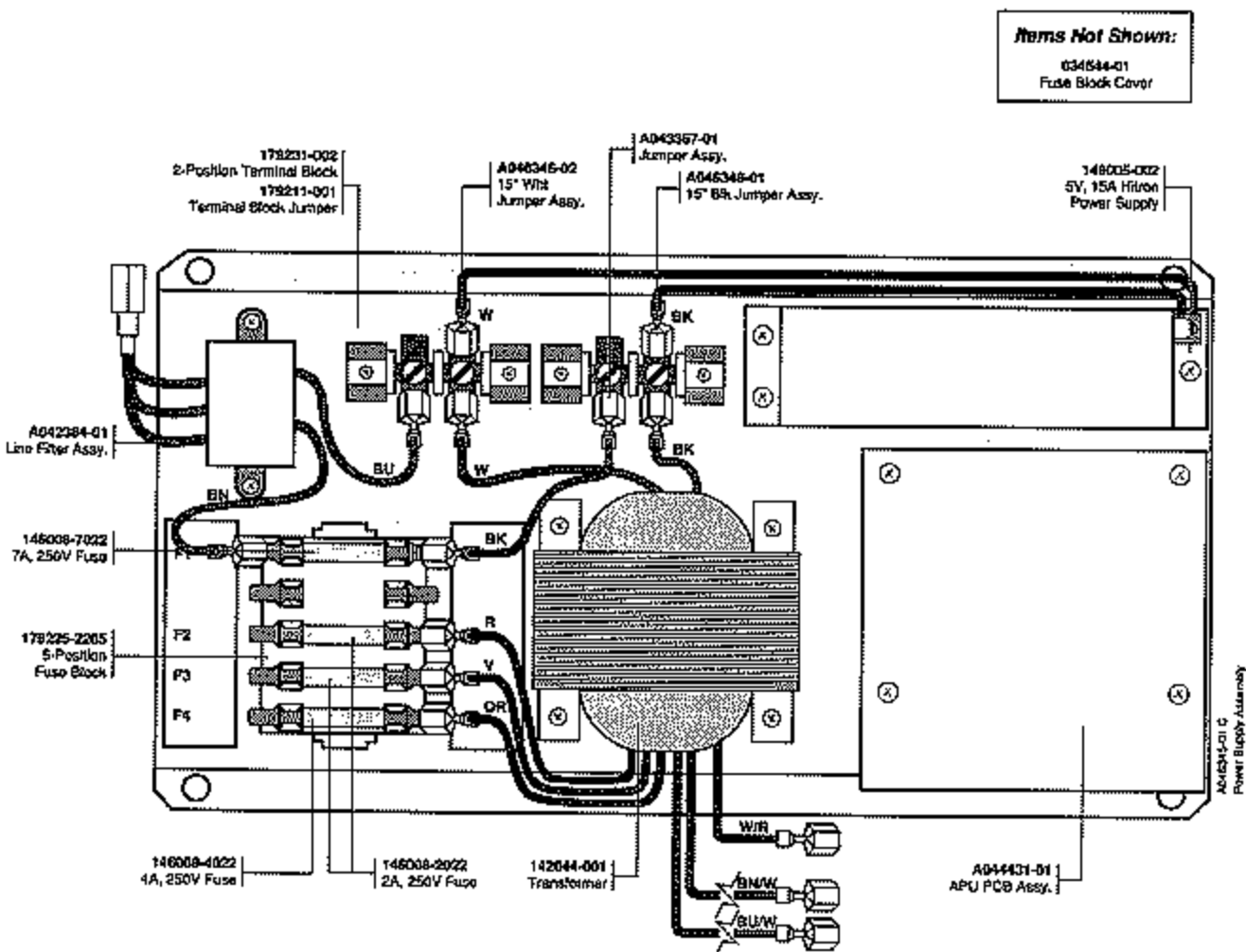


**Figure 4-9** Coin Acceptors, Inc. Coin Door Assembly, Continued  
171027-001

### Coin Acceptors, Inc. Coin Door Assembly Parts List

| Part No.   | Description  | Part No.   | Description                               |
|------------|--|------------|---|
| 160057-001 | Coin Switch  | 99-10081   | Key Holder                                |
| 70-11-17   | Miniature Bayonet Lamp   | 99-10096   | Fastener                                  |
| 72-9406S   | #4-40 x 3/8-Inch Truss-Head Screw                                    | 99-10104   | Bar Retainer                              |
| 72-HA1404C | #4-40 x 1/4-Inch Pan-Head Screw                                      | 99-10105   | Bar                                       |
| 72-JA1405B | #4-40 x .31-Inch Pan-Head Screw                                      | 99-10115   | Spring                                    |
| 75-1412S   | #4-40 x 3/4-Inch Pan-Head Screw                                      | 99-10116   | Plastic Coin Return Lever                 |
| 177010-232 | #4-40 Locknut  | 99-10117   | Steel Coin Return Door                    |
| 99-10008   | Retainer   | 99-10139   | Coin Door                                 |
| 99-10042   | Coin Switch Assembly for Belgian 5 Fr and U.S. 25¢                   | 99-10140   | Coin Door Inner-Panel Assembly            |
| 99-10043   | Coin Switch Assembly for German 1 DM, Japanese 100 Yen, Swiss 1 Fr   | 99-10141   | Die-Cast Coin Return Cover                |
| 99-10044   | Coin Switch Assembly for German 2 DM, Italian 100 L, U.S. \$1.00     | 99-10143   | Coin Door Frame                           |
| 99-10045   | Coin Switch Assembly for Australian \$.20, German 5 DM, British 10 P | 99-10144   | Channel Clip                              |
| 99-10068   | Coin Return Chute  | 99-10147   | Harness                                   |
| 99-10075   | Switch Wire (included in coin switch assembly 99-10043)              | 99-10148   | Lock Assembly                             |
| 99-10076   | Switch Wire (included in coin switch assembly 99-10042)              | 99-10149   | Service Door                              |
| 99-10077   | Switch Wire (included in coin switch assembly 99-10044)              | 99-10150   | Switch Cover                              |
| 99-10078   | Switch Wire (included in coin switch assembly 99-10045)              | 99-10151   | Left Coin Inlet                           |
| 99-10080   | Lamp Socket  | 99-10152   | Right Coin Inlet                          |
|            |  | 99-10153   | Coin Return Box                           |
|            |  | 99-10154   | Bracket Assembly                          |
|            |  | 99-10160   | 1-Inch Wide Die-Cast Coin Inlet Housing   |
|            |  | 99-10161   | 25¢ Amber Side-Entry Coin Button Assembly |
|            |  | 99-10170   | Screw for Clamp                           |
|            |  | 171006-035 | Metal Coin Mechanism for U.S. 25¢         |

# N O T E S



**Figure 4-10 Power Supply Assembly  
A046345-01 C**

## Power Supply Assembly Parts List

| Part No.   | Description  | Part No.    | Description   |
|------------|--|-------------|---|
| A042384-01 | Line Filter Assembly   | 146008-2022 | 2 Amp, 250V Slow-Blow Fuse                                  |
| A043367-01 | Jumper Assembly  | 146008-4022 | 4 Amp, 250 V, Slow-Blow Fuse                                |
| A044431-01 | Race Drivin' Audio Power Unit (APU) PCB Assembly (see Figure 4-12) | 146008-7022 | 7 Amp, 250 V, Slow-Blow Fuse                                |
| A046346-01 | 15-Inch Black Jumper Assembly                                      | 149005-002  | 5 V, 15 A Hitron Switching Power Supply (see details below) |
| A046346-02 | 15-Inch White Jumper Assembly                                      | 179211-001  | Terminal Block Jumper                                       |
| 034544-01  | Fuse Block Cover   | 179225-2205 | 5-Position Fuse Block                                       |
| 037640-01  | Power Supply Warning Label   | 179231-002  | 2-Position Terminal Block                                   |
| 044819-01  | Power Supply Chassis Base  | 72-1604F    | #6-32 x 1/4-Inch X-Rec Machine Screw                        |
| 046347-01  | Power Supply Fuse Label  | 72-HA4606S  | #6-32 x 3/8-Inch X-Rec Screw                                |
| 142044-001 | Transformer  | 72-HA4806S  | #8-32 x 3/8-Inch X-Rec Screw                                |

## Hitron 5V, 15 A Switching Power Supply Sub-Assembly Parts List

| Part No.           | Description  | Part No.  | Description  |
|--------------------|--|-----------|--|
| <b>Transistors</b> |  |           |  |
| 99-211002          | Transistor, NPN, 2SC1413A                              | 99-211026 | Resistor, Carbon Film, 330 $\Omega$ , $\pm 5\%$ , 1/4W |
| 99-211003          | Transistor, NPN, PE8050B                               | 99-211027 | Resistor, Carbon Film, 5.6 $\Omega$ , $\pm 5\%$ , 1/4W |
| 99-211004          | Transistor, PNP, PE8550B                               | 99-211028 | Resistor, Carbon Film, 8.2 $\Omega$ , $\pm 5\%$ , 1/4W |
| 99-211062          | Transistor, 2SD725                                     | 99-211029 | Resistor, Carbon Film, 10 $\Omega$ , $\pm 5\%$ , 1/4W  |
| 99-211063          | Transistor, PE8550B                                    | 99-211030 | Resistor, Carbon Film, 39 $\Omega$ , $\pm 5\%$ , 1/4W  |
| <b>Diodes</b>      |  |           |  |
| 99-211005          | Diode, Schottky, S10SC4M                               | 99-211031 | Resistor, Carbon Film, 56 $\Omega$ , $\pm 5\%$ , 1/4W  |
| 99-211006          | Diode, Fast Recovery, 30DF1                            | 99-211032 | Resistor, Carbon Film, 1K $\Omega$ , $\pm 5\%$ , 1/4W  |
| 99-211007          | Diode, Zener, 1N752A                                   | 99-211033 | Resistor, Metal Film, 2K $\Omega$ , $\pm 2\%$ , 1/4W   |
| 99-211008          | Diode, Rectifier, 1N4006                               | 99-211034 | Resistor, Carbon Film, 180K $\Omega$ , $\pm 5\%$ , 1W  |
| 99-211009          | Diode, Fast Recovery, RPG10B                           | 99-211035 | Resistor, Carbon Film, 2K $\Omega$ , $\pm 5\%$ , 1/4W  |
| 99-211010          | Diode, Fast Recovery, RPG10K                           | 99-211065 | Resistor, Wire Wound, 27 $\Omega$ , $\pm 5\%$ , 2W     |
| 99-211011          | Diode, Fast Recovery, RPG15B                           | 99-211066 | Resistor, Carbon Film, 6.8 $\Omega$ , $\pm 5\%$ , 1/2W |
| 99-211012          | Diode, Switching, 1N4148                               | 99-211067 | Resistor, Carbon Film, 12 $\Omega$ , $\pm 5\%$ , 1/4W  |
| 99-211064          | Diode, S15SC4M   | 99-211068 | Resistor, Carbon Film, 2.4 $\Omega$ , $\pm 5\%$ , 1/2W |
| 99-211076          | Diode, 31DQ04  | 99-211077 | Resistor, 470 $\Omega$ , 1/2W, $\pm 5\%$               |
| 99-211013          | Rectifier, Silicon-Controlled, S2800                   | 99-211078 | Resistor, 120K $\Omega$ , 1W, $\pm 5\%$                |
| <b>Resistors</b>   |  |           |  |
| 99-211014          | Potentiometer, Trimming, 3K $\Omega$                   | 99-211036 | Capacitor, Metal Film, 0.047 $\mu\text{F}$ , 250V      |
| 99-211015          | Resistor, Wire Wound, 50 $\Omega$ , $\pm 5\%$ , 2W     | 99-211037 | Capacitor, Metal Film, 0.22 $\mu\text{F}$ , 100V       |
| 99-211016          | Resistor, Wire Wound, 150 $\Omega$ , $\pm 5\%$ , 2W    | 99-211038 | Capacitor, Metal Film, 0.1 $\mu\text{F}$ , 400V        |
| 99-211017          | Resistor, Wire Wound, 33 $\Omega$ , $\pm 5\%$ , 2W     | 99-211039 | Capacitor, Metal Film, 0.022 $\mu\text{F}$ , 100V      |
| 99-211018          | Resistor, Wire Wound, 0.47 $\Omega$ , $\pm 5\%$ , 2W   | 99-211040 | Capacitor, Ceramic, 1800 pF, 2KV, Z5V                  |
| 99-211019          | Resistor, Wire Wound, 120 $\Omega$ , $\pm 5\%$ , 2W    | 99-211041 | Capacitor, Ceramic, 0.01 $\mu\text{F}$ , 1KV, Z5U      |
| 99-211020          | Thermistor, 0.5 $\Omega$ , $\pm 5\%$ , 5W              | 99-211042 | Capacitor, Ceramic, 0.001 $\mu\text{F}$ , 2KV          |
| 99-211021          | Resistor, 2.2K $\Omega$ , $\pm 2\%$ , 1/4W             | 99-211043 | Capacitor, Ceramic, 470 pF, 1KV, Z5P                   |
| 99-211022          | Resistor, Carbon Film, 330 $\Omega$ , $\pm 5\%$ , 1/2W | 99-211044 | Capacitor, Electrolytic, 470 $\mu\text{F}$ , 25V       |
| 99-211023          | Resistor, Carbon Film, 270 $\Omega$ , $\pm 5\%$ , 1/2W | 99-211045 | Capacitor, Electrolytic, 220 $\mu\text{F}$ , 25V       |
| 99-211024          | Resistor, Carbon Film, 470 $\Omega$ , $\pm 5\%$ , 1/4W | 99-211046 | Capacitor, Electrolytic, 100 $\mu\text{F}$ , 200V      |
| 99-211025          | Resistor, Carbon Film, 47 $\Omega$ , $\pm 5\%$ , 1/4W  | 99-211047 | Capacitor, Electrolytic, 1000 $\mu\text{F}$ , 25V      |
|                    |  | 99-211048 | Capacitor, Electrolytic, 2200 $\mu\text{F}$ , 16V      |
|                    |  | 99-211049 | Capacitor, Ceramic, 4700 $\mu\text{F}$ , 400V          |

**Hitron Power Supply Sub-Assembly, Continued**  
**Parts List**

| <b>Part No.</b> | <b>Description</b>                         | <b>Part No.</b> | <b>Description</b>        |
|-----------------|--|-----------------|---------------------------|
| 99-211069       | Capacitor, Electrolytic, 2200 $\mu$ F, 16V |                 | <b>Transformers</b>       |
| 99-211070       | Capacitor, Electrolytic, 220 $\mu$ F, 25V  | 99-211075       | Transformer, Power        |
| 99-211079       | Capacitor, DE7100F22M                      | 99-211083       | Transformer, Power        |
| 99-211080       | Capacitor, 1000 $\mu$ F, 35V               | 99-211089       | Transformer, 4.75 MH      |
| 99-211081       | Capacitor, 470 $\mu$ F, 25V                | 99-211092       | Transformer               |
| 99-211082       | Capacitor, 220 $\mu$ F, 16V                | 99-211055       | Transformer               |
| 99-211090       | Capacitor, Ceramic, 1000 pF, 2KV           |                 | <b>Miscellaneous</b>      |
| 99-211091       | Capacitor, Electrolytic, 2200 $\mu$ F, 10V | 99-211001       | Regulator, UA431AWC       |
|                 | <b>Inductors</b>                           | 99-211056       | Fuse, 2A, 250V            |
| 99-211050       | Inductor, 7 $\mu$ H                        | 99-211057       | Terminal Block, 8-Circuit |
| 99-211051       | Inductor, 7 $\mu$ H, 35 MM                 | 99-211058       | Fuse, 2A, 250V, Semko     |
| 99-211052       | Inductor, 15 MH                            |                 |                           |
| 99-211053       | Inductor, 1.5 MH                           | 99-211059       | Heat Sink                 |
| 99-211054       | Inductor, 2.2 $\mu$ H                      | 99-211060       | Fuse Holder, 6.35 MM      |
| 99-211071       | Inductor, 9.8 $\mu$ H                      | 99-211061       | Heat Sink, 1.5 MM         |
| 99-211084       | Inductor, 8 $\mu$ H                        | 99-211072       | Fuse Holder, 5.2 x 20     |
| 99-211085       | Inductor, 9.8 $\mu$ H                      |                 |                           |
| 99-211086       | Inductor, 0.75 MH                          | 99-211073       | Fuse, 2A, 125V            |
| 99-211087       | Inductor, 2.2 $\mu$ H                      | 99-211074       | Terminal Block, 9-Circuit |
| 99-211088       | Inductor, 60 MH                            |                 |                           |

# N O T E S





### Race Drivin' Main PCB Assembly Parts List

| Designator                 | Description   | Part No.   | Designator | Description   | Part No.   |
|----------------------------|---|------------|------------|---|------------|
| <b>Integrated Circuits</b> |   |            |            |   |            |
| 5K                         | NOT LOADED  |            | 80P, 80S   | Integrated Circuit, VRAM, 64Kx4, 150 nsec (Acceptable substitute is part no. 137553-001, Integrated Circuit, 64x4, VRAM, 120 nsec.) | 137553-002 |
| 5M                         | NOT LOADED  |            | 80U, 80W   | Integrated Circuit, VRAM, 64Kx4, 150 nsec (Acceptable substitute is part no. 137553-001, Integrated Circuit, 64x4, VRAM, 120 nsec.) | 137553-002 |
| 15B                        | Integrated Circuit, 74LS374   | 137144-001 | 80Y        | Integrated Circuit, 74AS08  | 137484-001 |
| 15K                        | NOT LOADED  |            | 85C        | Integrated Circuit, 74LS374   | 137144-001 |
| 15M                        | NOT LOADED  |            | 90P, 90S   | Integrated Circuit, VRAM, 64Kx4, 150 nsec (Acceptable substitute is part no. 137553-001, Integrated Circuit, 64x4, VRAM, 120 nsec.) | 137553-002 |
| 20P                        | Integrated Circuit, 74ALS574  | 137548-001 | 90U, 90W   | Integrated Circuit, VRAM, 64Kx4, 150 nsec (Acceptable substitute is part no. 137553-001, Integrated Circuit, 64x4, VRAM, 120 nsec.) | 137553-002 |
| 20S, 20U                   | Integrated Circuit, 74ASB23   | 137513-001 | 95C        | Integrated Circuit, 74LS374   | 137144-001 |
| 20W                        | Integrated Circuit, 74ASB23   | 137513-001 | 100K       | Integrated Circuit, 74LS74  | 137023-001 |
| 25K                        | NOT LOADED  |            | 100M       | Integrated Circuit, 74ALS08   | 137460-001 |
| 25M                        | NOT LOADED  |            | 100P, 100S | Integrated Circuit, VRAM, 64Kx4, 150 nsec (Acceptable substitute is part no. 137553-001, Integrated Circuit, 64x4, VRAM, 120 nsec.) | 137553-002 |
| 30B                        | Integrated Circuit, ADC0809   | 137243-001 | 100U, 100W | Integrated Circuit, VRAM, 64Kx4, 150 nsec (Acceptable substitute is part no. 137553-001, Integrated Circuit, 64x4, VRAM, 120 nsec.) | 137553-002 |
| 30D                        | Integrated Circuit, AD7582  | 137545-001 | 100Y       | Integrated Circuit, 74AS08  | 137484-001 |
| 30P                        | Integrated Circuit, 74LS245   | 137134-001 | 110C       | Integrated Circuit, 7406  | 137052-001 |
| 30S, 30U                   | Integrated Circuit, 45 nsec   | 137199-002 | 110K       | Integrated Circuit, 74ALS138  | 137517-001 |
| 30W                        | Integrated Circuit, 45 nsec   | 137199-002 | 110M       | Integrated Circuit, 74ALS138  | 137517-001 |
| 30Y                        | Integrated Circuit, 74LS245   | 137134-001 | 110P, 110S | Integrated Circuit, VRAM, 64Kx4, 150 nsec (Acceptable substitute is part no. 137553-001, Integrated Circuit, 64x4, VRAM, 120 nsec.) | 137553-002 |
| 35K                        | NOT LOADED  |            | 110U, 110W | Integrated Circuit, VRAM, 64Kx4, 150 nsec (Acceptable substitute is part no. 137553-001, Integrated Circuit, 64x4, VRAM, 120 nsec.) | 137553-002 |
| 35M                        | NOT LOADED  |            | 120H       | Integrated Circuit, 74F74   | 137436-001 |
| 40H                        | Integrated Circuit, 74LS123   | 137268-001 | 120K       | Integrated Circuit, 74LS393   | 137146-001 |
| 40S, 40U                   | Integrated Circuit, 45 nsec   | 137199-002 | 120M       | Integrated Circuit, 74ALS08   | 137460-001 |
| 40Y                        | Integrated Circuit, 74LS245   | 137134-001 | 120P, 120S | Integrated Circuit, VRAM, 64Kx4, 150 nsec (Acceptable substitute is part no. 137553-001, Integrated Circuit, 64x4, VRAM, 120 nsec.) | 137553-002 |
| 50B, 50D                   | Integrated Circuit, 74LS244   | 137038-001 | 120U, 120W | Integrated Circuit, VRAM, 64Kx4, 150 nsec (Acceptable substitute is part no. 137553-001, Integrated Circuit, 64x4, VRAM, 120 nsec.) | 137553-002 |
| 50H                        | Integrated Circuit, 74LS123   | 137268-001 |            |   |            |
| 50S, 50U                   | Integrated Circuit, 74ALS574  | 137548-001 |            |   |            |
| 50W                        | Integrated Circuit, 74ALS574  | 137548-001 |            |   |            |
| 50Y                        | Integrated Circuit, 74AS573   | 137547-001 |            |   |            |
| 55L-MSP                    | NOT LOADED  |            |            |   |            |
| 60P, 60S                   | Integrated Circuit, VRAM, 64Kx4, 150 nsec (Acceptable substitute is part no. 137553-001, Integrated Circuit, 64x4, VRAM, 120 nsec.) | 137553-002 |            |   |            |
| 60U, 60W                   | Integrated Circuit, VRAM, 64Kx4, 150 nsec (Acceptable substitute is part no. 137553-001, Integrated Circuit, 64x4, VRAM, 120 nsec.) | 137553-002 |            |   |            |
| 65C                        | Integrated Circuit, 74LS259   | 137137-001 |            |   |            |
| 70P, 70S                   | Integrated Circuit, VRAM, 64Kx4, 150 nsec (Acceptable substitute is part no. 137553-001, Integrated Circuit, 64x4, VRAM, 120 nsec.) | 137553-002 |            |   |            |
| 70U, 70W                   | Integrated Circuit, VRAM, 64Kx4, 150 nsec (Acceptable substitute is part no. 137553-001, Integrated Circuit, 64x4, VRAM, 120 nsec.) | 137553-002 |            |   |            |
| 75C                        | Integrated Circuit, 74LS259   | 137137-001 |            |   |            |
| 75H                        | Integrated Circuit, 74LS14  | 137056-001 |            |   |            |

### Race Drivin' Main PCB Assembly Parts List

| Designator | Description   | Part No.   | Designator  | Description                             | Part No.    |
|------------|---|------------|---|---|-------------|
| 130M       | Integrated Circuit, 74ALS161  | 137470-001 | 190N  | Integrated Circuit, 74LS245             | 137134-001  |
| 130P, 130S | Integrated Circuit, VRAM, 64Kx4, 150 nsec (Acceptable substitute is part no. 137553-001, Integrated Circuit, 64x4, VRAM, 120 nsec.) | 137553-002 | 190U  | Integrated Circuit, 74AS32              | 137487-001  |
| 130U, 150W | Integrated Circuit, VRAM, 64Kx4, 150 nsec (Acceptable substitute is part no. 137553-001, Integrated Circuit, 64x4, VRAM, 120 nsec.) | 137553-002 | 190W  | Integrated Circuit, 74ALS74             | 137156-001  |
| 135C       | Integrated Circuit, 74F74   | 137436-001 | 190Y  | Integrated Circuit, 74LS259             | 137137-001  |
| 135H       | Integrated Circuit, 74F74   | 137436-001 | 200A  | Integrated Circuit, 68681               | 137543-001  |
| 135K       | Integrated Circuit, 74AS32  | 137487-001 | 200C, 200D  | Integrated Circuit, RAM, 8Kx8, 150 nsec | 137535-006  |
| 140C       | Integrated Circuit, 74LS244   | 137038-001 | 200E  | Integrated Circuit, 48TD2-15, RAM       | 137540-150  |
| 140H       | Integrated Circuit, 74LS393   | 137146-001 | 200F  | Integrated Circuit, 74LS245             | 137134-001  |
| 140K       | Integrated Circuit, 74F11   | 137583-001 | 200H, 200J  | Integrated Circuit, 74LS244             | 137038-001  |
| 140M       | Integrated Circuit, 74ALS574  | 137548-001 | 200K  | Integrated Circuit, SLAPSTIC 117        | 137412-117  |
| 150C       | Integrated Circuit, 74LS245   | 137134-001 | 200L  | Integrated Circuit, 74ALS32             | 137464-001  |
| 150E       | Integrated Circuit, 74LS244   | 137038-001 | 200M  | Integrated Circuit, 74ALS138            | 137517-001  |
| 150H       | Integrated Circuit, 74LS74  | 137023-001 | 200N, 200P  | Integrated Circuit, 74LS245             | 137134-001  |
| 150K       | Integrated Circuit, 74LS20  | 137060-001 | <b>The following 16 program chips are for North American left-hand-drive simulators only:</b> |   |             |
| 150P       | Integrated Circuit, 74AS573   | 137547-001 | 200R  | Integrated Circuit, PR EPROM            | 136077-2002 |
| 150S-PSP   | Integrated Circuit  | 137559-001 | 200S  | Integrated Circuit, PR EPROM            | 136077-2004 |
| 150U       | Integrated Circuit, 74F244  | 137502-001 | 200T  | Integrated Circuit, PR EPROM            | 136077-2006 |
| 150W       | Integrated Circuit, 74AS573   | 137547-001 | 200U  | Integrated Circuit, PR EPROM            | 136077-2008 |
| 160C       | Integrated Circuit, 74LS244   | 137038-001 | 200V  | Integrated Circuit, PR EPROM            | 136077-2010 |
| 160E       | Integrated Circuit, 74ALS161  | 137470-001 | 200W  | Integrated Circuit, PR EPROM            | 136077-1012 |
| 160H       | Integrated Circuit, 74ALS32   | 137464-001 | 200X  | Integrated Circuit, PR EPROM            | 136077-1014 |
| 160K       | Integrated Circuit, 74ALS138  | 137517-001 | 200Y  | Integrated Circuit, PR EPROM            | 136077-1016 |
| 160M       | Integrated Circuit, 74F04   | 137437-001 | 210R  | Integrated Circuit, PR EPROM            | 136077-2001 |
| 160P       | Integrated Circuit, 74AS573   | 137547-001 | 210S  | Integrated Circuit, PR EPROM            | 136077-2003 |
| 160U       | Integrated Circuit, 74AS00  | 137480-001 | 210T  | Integrated Circuit, PR EPROM            | 136077-2005 |
| 160W       | Integrated Circuit, 74AS573   | 137547-001 | 210U  | Integrated Circuit, PR EPROM            | 136077-2007 |
| 170C       | Integrated Circuit, 74LS245   | 137134-001 | 210V  | Integrated Circuit, PR EPROM            | 136077-2009 |
| 170E       | Integrated Circuit, 74LS244   | 137038-001 | 210W  | Integrated Circuit, PR EPROM            | 136077-1011 |
| 170H       | Integrated Circuit, 74LS148   | 137417-001 | 210X  | Integrated Circuit, PR EPROM            | 136077-1013 |
| 170K       | Integrated Circuit, 74ALS161  | 137470-001 | 210Y  | Integrated Circuit, PR EPROM            | 136077-1015 |
| 170P       | Integrated Circuit, 74LS244   | 137038-001 | <b>The following 16 program chips are for German left-hand-drive simulators only:</b>         |   |             |
| 170U       | Integrated Circuit, 74AS08  | 137484-001 | 200R  | Integrated Circuit, PR EPROM            | 136077-1202 |
| 180C       | Integrated Circuit, 74ALS138  | 137517-001 | 200S  | Integrated Circuit, PR EPROM            | 136077-1204 |
| 180E       | Integrated Circuit, 74ALS139  | 137467-001 | 200T  | Integrated Circuit, PR EPROM            | 136077-1206 |
| 180S-GSP   | Integrated Circuit, 34010-50  | 137538-002 | 200U  | Integrated Circuit, PR EPROM            | 136077-1208 |
| 180U       | Integrated Circuit, 74AS573   | 137547-001 | 200V  | Integrated Circuit, PR EPROM            | 136077-1210 |
| 180W       | Integrated Circuit, 74F04   | 137437-001 | 200W  | Integrated Circuit, PR EPROM            | 136077-1012 |
| 180Y       | Integrated Circuit, 74AS573   | 137547-001 | 200X  | Integrated Circuit, PR EPROM            | 136077-1014 |
| 190C       | Integrated Circuit, 74LS393   | 137146-001 | 200Y  | Integrated Circuit, PR EPROM            | 136077-1016 |
| 190E       | Integrated Circuit, 74AS00  | 137480-001 | 210R  | Integrated Circuit, PR EPROM            | 136077-1201 |
| 190K       | Integrated Circuit, 68010   | 137414-002 | 210S  | Integrated Circuit, PR EPROM            | 136077-1203 |
|            |   |            | 210T  | Integrated Circuit, PR EPROM            | 136077-1205 |
|            |   |            | 210U  | Integrated Circuit, PR EPROM            | 136077-1207 |
|            |   |            | 210V  | Integrated Circuit, PR EPROM            | 136077-1209 |
|            |   |            | 210W  | Integrated Circuit, PR EPROM            | 136077-1011 |
|            |   |            | 210X  | Integrated Circuit, PR EPROM            | 136077-1013 |
|            |   |            | 210Y  | Integrated Circuit, PR EPROM            | 136077-1015 |

## Race Drivin' Main PCB Assembly Parts List, Continued

| Designator   | Description                             | Part No.    | Designator   | Description                                | Part No.   |
|--|---|-------------|--|--|------------|
| <p>The following 16 program chips are for British right-hand-drive simulators only:</p>  |   |             | <p style="text-align: center;"><b>Capacitors</b></p> |  |            |
| 200R   | Integrated Circuit, PR EPROM            | 136077-2002 | C1   | Capacitor, 100 $\mu$ F, 35 V, Electrolytic | 124000-107 |
| 200S   | Integrated Circuit, PR EPROM            | 136077-1104 | C2   | Capacitor, .01 $\mu$ F, 50 V, Ceramic      | 122002-103 |
| 200T   | Integrated Circuit, PR EPROM            | 136077-1106 | C3-C43   | Capacitor, .1 $\mu$ F, 50 V, Ceramic       | 122002-104 |
| 200U   | Integrated Circuit, PR EPROM            | 136077-1008 | C44-C63  | Capacitor, .001 $\mu$ F, 50 V, $\pm$ 10%   | 122015-102 |
| 200V   | Integrated Circuit, PR EPROM            | 136077-1010 | C64-C78  | Capacitor, .1 $\mu$ F, 50 V, Ceramic       | 122002-104 |
| 200W   | Integrated Circuit, PR EPROM            | 136077-1112 | C79  | Capacitor, 10 pF, 100 V, Ceramic           | 122016-100 |
| 200X   | Integrated Circuit, PR EPROM            | 136077-1014 | C80-C82  | Capacitor, .1 $\mu$ F, 50 V, Ceramic       | 122002-104 |
| 200Y   | Integrated Circuit, PR EPROM            | 136077-1016 | C83, C84   | Capacitor, 100 pF, 100 V, Ceramic          | 122016-101 |
| 210R   | Integrated Circuit, PR EPROM            | 136077-2001 | C85-C87  | Capacitor, .1 $\mu$ F, 50 V, Ceramic       | 122002-104 |
| 210S   | Integrated Circuit, PR EPROM            | 136077-1103 | C88-C91  | Capacitor, .22 $\mu$ F, 50 V, Ceramic      | 122015-224 |
| 210T   | Integrated Circuit, PR EPROM            | 136077-1105 | C92  | Capacitor, .1 $\mu$ F, 50 V, Ceramic       | 122002-104 |
| 210U   | Integrated Circuit, PR EPROM            | 136077-1007 | C93  | Capacitor, 10 $\mu$ F, 35 V, Electrolytic  | 124000-106 |
| 210V   | Integrated Circuit, PR EPROM            | 136077-1009 | C94-C106   | Capacitor, .1 $\mu$ F, 50 V, Ceramic       | 122002-104 |
| 210W   | Integrated Circuit, PR EPROM            | 136077-1111 | C108-C111  | Capacitor, .22 $\mu$ F, 50 V, Ceramic      | 122015-224 |
| 210X   | Integrated Circuit, PR EPROM            | 136077-1013 | C112-C118  | Capacitor, .1 $\mu$ F, 50 V, Ceramic       | 122002-104 |
| 210Y   | Integrated Circuit, PR EPROM            | 136077-1015 | C119   | Capacitor, 3900 pF, 50 V, Ceramic          | 122020-392 |
| <p>The following 16 program chips are for Japanese right-hand-drive simulators only:</p> |   |             | C120   | Capacitor, 560 pF, 50 V, Ceramic           | 122020-561 |
| 200R   | Integrated Circuit, PR EPROM            | 136077-1402 | C121   | Capacitor, 10 $\mu$ F, 35 V, Electrolytic  | 124000-106 |
| 200S   | Integrated Circuit, PR EPROM            | 136077-1404 | C122   | Capacitor, .0022 $\mu$ F, 100 V, Plastic   | 121022-222 |
| 200T   | Integrated Circuit, PR EPROM            | 136077-1406 | C123   | Capacitor, .1 $\mu$ F, 50 V, Ceramic       | 122002-104 |
| 200U   | Integrated Circuit, PR EPROM            | 136077-1408 | C124   | Capacitor, .1 $\mu$ F, 50 V, Ceramic       | 122002-104 |
| 200V   | Integrated Circuit, PR EPROM            | 136077-1410 | C125-C128  | Capacitor, 10 $\mu$ F, 35 V, Electrolytic  | 124000-106 |
| 200W   | Integrated Circuit, PR EPROM            | 136077-1412 | C129-C137  | Capacitor, .1 $\mu$ F, 50 V, Ceramic       | 122002-104 |
| 200X   | Integrated Circuit, PR EPROM            | 136077-1414 | C138   | Capacitor, 1000 pF, 100 V, Ceramic         | 122016-102 |
| 200Y   | Integrated Circuit, PR EPROM            | 136077-1416 | C139   | Capacitor, 1000 pF, 100 V, Ceramic         | 122016-102 |
| 210R   | Integrated Circuit, PR EPROM            | 136077-1401 | C140   | Capacitor, .1 $\mu$ F, 50 V, Ceramic       | 122002-104 |
| 210S   | Integrated Circuit, PR EPROM            | 136077-1403 | C141   | Capacitor, .1 $\mu$ F, 50 V, Ceramic       | 122002-104 |
| 210T   | Integrated Circuit, PR EPROM            | 136077-1405 | C142   | Capacitor, .22 $\mu$ F, 50 V, Ceramic      | 122015-224 |
| 210U   | Integrated Circuit, PR EPROM            | 136077-1407 | C143   | Capacitor, .1 $\mu$ F, 50 V, Ceramic       | 122002-104 |
| 210V   | Integrated Circuit, PR EPROM            | 136077-1409 | C144   | Capacitor, .1 $\mu$ F, 50 V, Ceramic       | 122002-104 |
| 210W   | Integrated Circuit, PR EPROM            | 136077-1411 | C145   | Capacitor, 10 $\mu$ F, 35 V, Electrolytic  | 124000-106 |
| 210X   | Integrated Circuit, PR EPROM            | 136077-1413 | C146-C227  | Capacitor, .1 $\mu$ F, 50 V, Ceramic       | 122002-104 |
| 210Y   | Integrated Circuit, PR EPROM            | 136077-1415 | C228   | Capacitor, .001 $\mu$ F, 50 V, $\pm$ 10%   | 122015-102 |
| 205B   | Integrated Circuit, 4066B               | 137580-001  | C229   | Capacitor, 47 pF, 100 V, Ceramic           | 122016-470 |
| 210A   | Integrated Circuit, MC1488              | 137403-001  | C230-C249  | Capacitor, .1 $\mu$ F, 50 V, Ceramic       | 122002-104 |
| 210B   | Integrated Circuit, MC1489AI            | 137263-001  | C250   | Capacitor, 47 pF, 100 V, Ceramic           | 122016-470 |
| 210C   | Integrated Circuit, RAM, 8Kx8, 150 nsec | 137535-006  | C251-C273  | Capacitor, .1 $\mu$ F, 50 V, Ceramic       | 122002-104 |
| 210D   | Integrated Circuit, RAM, 8Kx8, 150 nsec | 137535-006  | C274   | Capacitor, 47 pF, 100 V, Ceramic           | 122016-470 |
| 210E   | Integrated Circuit, 48Z02-15, RAM       | 137442-150  | C275-C320  | Capacitor, .1 $\mu$ F, 50 V, Ceramic       | 122002-104 |
| 210F   | Integrated Circuit, 74LS245             | 137134-001  | C322   | Capacitor, 10 $\mu$ F, 35 V, Electrolytic  | 124000-106 |
| 210H   | Integrated Circuit, 74LS244             | 137038-001  | C323-C326  | Capacitor, 10 pF, 100 V, Ceramic           | 122016-100 |
| 210J   | Integrated Circuit, 74LS244             | 137038-001  | C330-C333  | Capacitor, .1 $\mu$ F, 50 V, Ceramic       | 122002-104 |
| 210K   | Integrated Circuit, 74LS244             | 137038-001  | C335   | Capacitor, 100 pF, 100 V, Ceramic          | 122016-101 |
| 210L   | Integrated Circuit, 74LS245             | 137134-001  | C336   | Capacitor, 100 pF, 100 V, Ceramic          | 122016-101 |
| 210M   | Integrated Circuit, 74LS245             | 137134-001  | C337-C342  | Capacitor, .1 $\mu$ F, 50 V, Ceramic       | 122002-104 |
| 210N   | Integrated Circuit, 74LS244             | 137038-001  | C344-C346  | Capacitor, .1 $\mu$ F, 50 V, Ceramic       | 122002-104 |
| 210P   | Integrated Circuit, 74LS245             | 137134-001  | C347   | Capacitor, 10 $\mu$ F, 35 V, Electrolytic  | 124000-106 |

### Race Drivin' Main PCB Assembly Parts List, Continued

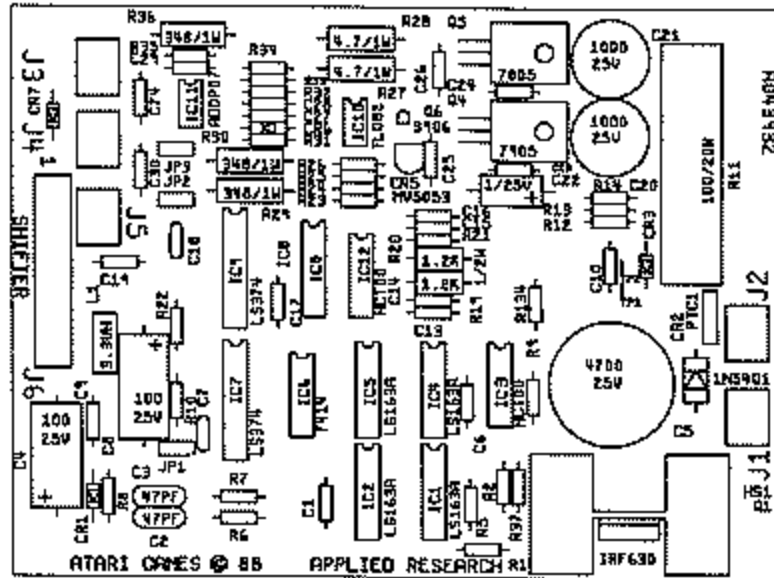
| Designator         | Description   | Part No.    | Designator           | Description   | Part No.   |
|--------------------|---|-------------|----------------------|---|------------|
| <b>Diodes</b>      |   |             |                      |   |            |
| CR1, CR2           | Diode, MV5053, Light Emitting                           | 131027-002  | R113-R115            | Resistor, 100 $\Omega$ , $\pm 5\%$ , 1/4 W                | 110000-101 |
| CR3, CR4           | Diode, 1N914  | 131052-001  | R116-R123            | Resistor, 33 $\Omega$ , $\pm 5\%$ , 1/4 W                 | 110000-330 |
| CR5                | Diode, 1N4002   | 131048-002  | R124                 | Resistor, 220 $\Omega$ , $\pm 5\%$ , 1/4 W                | 110000-221 |
| CR6                | Diode, MV5053, Light Emitting                           | 131027-002  | R125-R131            | Resistor, 1 K $\Omega$ , $\pm 5\%$ , 1/4 W                | 110000-102 |
| CR7, CR8           | Diode, 1N4002   | 131048-002  | R132                 | Resistor, 4.7 K $\Omega$ , $\pm 5\%$ , 1/4 W              | 110000-472 |
| CR9-CR12           | Diode, MV5053, Light Emitting                           | 131027-002  | R134                 | Resistor, 1 K $\Omega$ , $\pm 5\%$ , 1/4 W                | 110000-102 |
| CR13               | Diode, 1N4002   | 131048-002  | R144                 | Resistor, 620 $\Omega$ , $\pm 5\%$ , 1/4 W                | 110000-621 |
| CR14               | Diode, MV5053, Light Emitting                           | 131027-002  | R145, R146           | Resistor, 10 K $\Omega$ , $\pm 5\%$ , 1/4 W               | 110000-103 |
| CR17               | Diode, 1N4733 A, 5.1 V, Zener                           | 131009-206  | R147, R148           | Resistor, 100 K $\Omega$ , $\pm 5\%$ , 1/4 W              | 110000-104 |
| CR18, CR19         | Diode, 1N4002   | 131048-002  | R149, R150           | Resistor, 10 K $\Omega$ , $\pm 5\%$ , 1/4 W               | 110000-103 |
| CR20               | Diode, 1N4742 A, 12 V, Zener                            | 131009-215  | R151, R152           | Resistor, 220 $\Omega$ , $\pm 5\%$ , 1/4 W                | 110000-221 |
| <b>Transistors</b> |   |             |                      |   |            |
| Q1, Q2             | Transistor, 2N6044                                      | 133042-001  | R155                 | Resistor, 0 $\Omega$ , $\pm 5\%$ , 1/4 W                  | 110005-001 |
| Q3                 | Integrated Circuit, 7905                                | 137581-001  | R156-R159            | Resistor, 5.6 K $\Omega$ , $\pm 5\%$ , 1/4 W              | 110000-562 |
| Q4                 | Integrated Circuit, 7812                                | 137597-001  | R160, R161           | Resistor, 10 K $\Omega$ , $\pm 5\%$ , 1/4 W               | 110000-103 |
| Q5                 | Transistor, 2N3904                                      | 133041-001  | R162, R163           | Resistor, 150 $\Omega$ , $\pm 5\%$ , 1/4 W                | 110000-151 |
| Q6                 | Transistor, 2N3906                                      | 133040-001  | R164, R165           | Resistor, 10 $\Omega$ , $\pm 5\%$ , 1/4 W                 | 110000-100 |
| Q7                 | Transistor, 2N3904                                      | 133041-001  | R166                 | Resistor, 68 $\Omega$ , $\pm 5\%$ , 1/4 W                 | 110000-680 |
| Q8                 | Transistor, 2N3906                                      | 133040-001  | R167                 | Resistor, 91 $\Omega$ , $\pm 5\%$ , 1/4 W                 | 110000-910 |
| Q9                 | Transistor, 2N3904                                      | 133041-001  | RN1, RN2             | Resistor Network, 470x9, $\pm 5\%$ , 1/8 W, SIP (10-Pin)  | 118010-471 |
| Q10                | Transistor, 2N3906                                      | 133040-001  | RN3-RN5              | Resistor Network, R2R Ladder                              | 118015-001 |
| Q11-Q13            | Transistor, 2N3904                                      | 133041-001  | RN6                  | Resistor Network, 4.7Kx9, $\pm 5\%$ , 1/8 W, SIP (10-Pin) | 118010-472 |
| <b>Resistors</b>   |   |             |                      |   |            |
| R1-R26             | Resistor, 100 $\Omega$ , $\pm 5\%$ , 1/4 W              | 110000-101  | <b>Crystals</b>      |   |            |
| R27-R45            | Resistor, 1 K $\Omega$ , $\pm 5\%$ , 1/4 W              | 110000-102  | XOSC1                | Oscillator, 32 MHz  | 144008-002 |
| R46-R48            | Resistor, 470 $\Omega$ , $\pm 5\%$ , 1/4 W              | 110000-471  | XOSC2                | Crystal, 48 MHz, Oscillator Module                        | 144008-003 |
| R49-R54            | Resistor, 4.7 K $\Omega$ , $\pm 5\%$ , 1/4 W            | 110000-472  | XOSC3                | NOT LOADED  |            |
| R55, R56           | Resistor, 100, $\pm 5\%$ , 1/4 W                        | 110000-101  | XTAL1                | Crystal, 3.6864, Standup                                  | 144000-011 |
| R57, R58           | Resistor, 1 K $\Omega$ , $\pm 5\%$ , 1/4 W              | 110000-102  | <b>Miscellaneous</b> |   |            |
| R61                | Resistor, 4.7 K $\Omega$ , $\pm 5\%$ , 1/4 W            | 110000-472  |                      | Socket, 28 Pin, .600"                                     | 179257-028 |
| R62, R63           | Resistor, 220 $\Omega$ , $\pm 5\%$ , 1/4 W              | 110000-221  |                      | Socket, 68 Pin  | 179257-068 |
| R64-R67            | Resistor, 5.6 K $\Omega$ , $\pm 5\%$ , 1/4 W            | 110000-562  |                      | Socket, 64 Pin, .900"                                     | 179256-064 |
| R68                | Resistor, 1 K $\Omega$ , $\pm 5\%$ , 1/4 W              | 110000-102  |                      | Socket, 40 Pin, .600"                                     | 179257-040 |
| R69                | Resistor, Metal Film, 56 K $\Omega$ , $\pm 1\%$ , 1/4 W | 110011-5602 |                      | Socket, 20 Pin  | 179259-020 |
| R70-R73            | Resistor, 220 $\Omega$ , $\pm 5\%$ , 1/4 W              | 110000-221  |                      | Socket, 24 Pin, .600"                                     | 179257-024 |
| R74, R75           | Resistor, 10 K $\Omega$ , $\pm 5\%$ , 1/4 W             | 110000-103  | J1                   | Test Point  | 179051-001 |
| R76                | Resistor, 220 $\Omega$ , $\pm 5\%$ , 1/4 W              | 110000-221  |                      | Connector, 12 Circuit, Header .250 Ctr                    | 179069-012 |
| R77, R78           | Resistor, 4.7 K $\Omega$ , $\pm 5\%$ , 1/4 W            | 110000-472  | J2-J6                | Connector, 11 Circuit, Header, .100 Ctr                   | 179118-011 |
| R79                | Resistor, 47 K $\Omega$ , $\pm 5\%$ , 1/4 W             | 110000-473  | J7                   | Connector, 60 Circuit, Header, .100 Ctr                   | 179021-060 |
| R80, R81           | Resistor, 1 K $\Omega$ , $\pm 5\%$ , 1/4 W              | 110000-102  | J8-J11               | Connector, 11 Circuit, Header, .100 Ctr                   | 179118-011 |
| R82, R83           | Resistor, 470 $\Omega$ , $\pm 5\%$ , 1/4 W              | 110000-471  | J12                  | Connector, 9 Circuit, Header, .250 Ctr                    | 179059-009 |
| R84-R88            | Resistor, 10 K $\Omega$ , $\pm 5\%$ , 1/4 W             | 110000-103  | J14                  | Connector, 26 Circuit, Header, .1 x .1 Dual               | 179261-026 |
| R89-R96            | Resistor, 33 $\Omega$ , $\pm 5\%$ , 1/4 W               | 110000-330  | J15                  | Connector, 16 Circuit, Header, .1 x .1 Dual               | 179261-016 |
| R98-R101           | Resistor, 100 $\Omega$ , $\pm 5\%$ , 1/4 W              | 110000-101  | SW1                  | Switch, 8 Position DIP                                    | 160031-008 |
| R102-R107          | Resistor, 33 $\Omega$ , $\pm 5\%$ , 1/4 W               | 110000-330  |                      |   |            |
| R109-R111          | Resistor, 100 $\Omega$ , $\pm 5\%$ , 1/4 W              | 110000-101  |                      |   |            |

# N O T E S



### APU PCB Assembly Parts List

| Designator        | Description   | Part No.   | Designator           | Description                                       | Part No.    |
|-------------------|---|------------|----------------------|---|-------------|
| <b>Capacitors</b> |   |            | <b>Fuse</b>          |   |             |
| C1                | Capacitor, .1 $\mu$ F, 50 V, Ceramic                | 122002-104 | FU2                  | Fuse, 3 Amp, 250 V, Norm                          | 146007-3022 |
| C2                | Capacitor, .22 $\mu$ F, 50 V, Ceramic               | 122015-224 | <b>Transistors</b>   |   |             |
| C3                | Capacitor, .1 $\mu$ F, 50 V, Ceramic                | 122002-104 | Q1, Q2               | Integrated Circuit, TDA2030                       | 137301-001  |
| C4                | Capacitor, .001 $\mu$ F, 50 V, Ceramic              | 122002-102 | Q3                   | Integrated Circuit, 7815, Standup                 | 137598-001  |
| C5                | Capacitor, .22 $\mu$ F, 50 V, Ceramic               | 122015-224 | Q6                   | Transistor, TIP33, 40 V, 80 W                     | 133044-001  |
| C6                | Capacitor, 22 $\mu$ F, 35 V, Electrolytic           | 124000-226 | Q7                   | Transistor, Mps-U07, 100 V, 2 A                   | 133003-001  |
| C7-C14            | Capacitor, .1 $\mu$ F, 50 V, Ceramic                | 122002-104 | <b>Resistor</b>      |   |             |
| C15-C18           | Capacitor, 3300 $\mu$ F, 25 V, Electrolytic, Radial | 123003-338 | R1                   | Resistor, 10 K $\Omega$ , $\pm$ 5%, 1/4 W         | 110000-103  |
| C19               | Capacitor, .1 $\mu$ F, 50 V, Ceramic                | 122002-104 | R2                   | Resistor, 1 $\Omega$ , $\pm$ 5%, 1/4 W            | 110000-010  |
| C20, C21          | Capacitor, 3300 $\mu$ F, 25 V, Electrolytic, Radial | 123003-338 | R3, R4               | Resistor, 22 K $\Omega$ , $\pm$ 5%, 1/4 W         | 110000-223  |
| C22               | Capacitor, 22 $\mu$ F, 35 V, Electrolytic           | 124000-226 | R5                   | Resistor, 1 K $\Omega$ , $\pm$ 5%, 1/4 W          | 110000-102  |
| C23               | Capacitor, .22 $\mu$ F, 50 V, Ceramic               | 122015-224 | R6                   | Resistor, 10 $\Omega$ , $\pm$ 5%, 1/4 W           | 110000-100  |
| C24               | Capacitor, .1 $\mu$ F, 50 V, Ceramic                | 122002-104 | R7                   | Resistor, 1 K $\Omega$ , $\pm$ 5%, 1/4 W          | 110000-102  |
| C25               | Capacitor, .001 $\mu$ F, 50 V, Ceramic              | 122002-102 | R8, R9               | Resistor, 22 K $\Omega$ , $\pm$ 5%, 1/4 W         | 110000-223  |
| C26               | Capacitor, .22 $\mu$ F, 50 V, Ceramic               | 122015-224 | R10                  | Resistor, 1 $\Omega$ , $\pm$ 5%, 1/4 W            | 110000-010  |
| C27               | Capacitor, .1 $\mu$ F, 50 V, Ceramic                | 122002-104 | R11                  | Resistor, 10 K $\Omega$ , $\pm$ 5%, 1/4 W         | 110000-103  |
| C28               | Capacitor, 10 $\mu$ F, 25 V, Electrolytic           | 124009-106 | R20                  | Resistor, 47 $\Omega$ , $\pm$ 5%, 1/4 W           | 110000-470  |
| C29               | Capacitor, .1 $\mu$ F, 50 V, Ceramic                | 122002-104 | R21                  | Resistor, 1 K $\Omega$ , $\pm$ 5%, 1/4 W          | 110000-102  |
| C31               | Capacitor, 1000 $\mu$ F, 25 V, Radial               | 123003-108 | R22, R23             | Resistor, 1 $\Omega$ , $\pm$ 5%, 1 W, Carbon Film | 110030-010  |
|                   |   |            | R24                  | Resistor, 2.2 $\Omega$ , $\pm$ 5%, 1/2 W          | 110001-022  |
| <b>Diodes</b>     |   |            | <b>Miscellaneous</b> |   |             |
| CR1-CR6           | Diode, 1N4001                                       | 13104B-001 | FM1, FM2             | Fuse Clip   | 179050-002  |
| CR7-CR12          | Diode, 1N5401                                       | 131051-002 | HS1, HS2             | Heat Sink, TDA2030                                | 178190-032  |
| CR19              | Diode, 1N5401                                       | 131051-002 | HS3                  | Heat Sink, 7815                                   | 178190-124  |
|                   |   |            | JCDL                 | Connector, 2 Ckt, Header, .156 Ctr                | 179213-002  |
|                   |   |            | J1                   | Connector, 9-Circuit, Header, .156 Ctr            | 179213-009  |
|                   |   |            | JP                   | Connector, 3-Circuit, Header, .156 Ctr            | 179213-003  |
|                   |   |            | JSPK, JCCC           | Connector, 6-Circuit, Header, .156 Ctr            | 179213-006  |
|                   |   |            | JALX, JACDC          | Connector, 9-Circuit, Header, .156 Ctr            | 179213-009  |



NOTES :

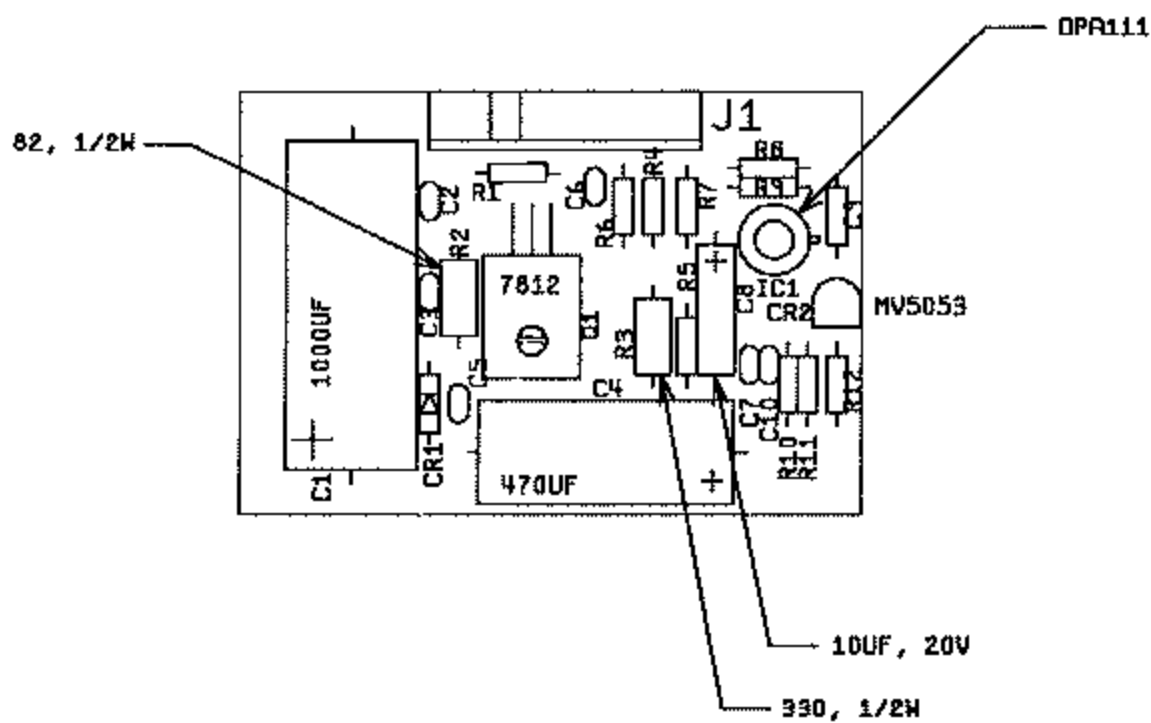
1. ADD RESISTOR, R135, BETWEEN THE CATHODE OF CR2 AND THE LARGE HEAT SINK PAD ON THE ANODE SIDE OF CR3.
2. ADD A JUMPER BETWEEN IC7 PIN 2 AND IC3 PIN 2.

Figure 4-13 Shifter PCB Assembly  
A043932-02 A



## Shifter PCB Assembly Parts List

| Designator                 | Description   | Part No.   | Designator           | Description  | Part No.    |
|----------------------------|---|------------|----------------------|--|-------------|
| <b>Capacitors</b>          |   |            | <b>Transistors</b>   |  |             |
| C1                         | Capacitor, .1 $\mu$ F, 50 V, Ceramic                | 122002-104 | Q1                   | Transistor, FET, IRF630  | 133039-001  |
| C2, C3                     | Capacitor, 47 pF, 100 V, Mica                       | 128002-470 | Q4                   | Integrated Circuit, 7905   | 137581-001  |
| C4                         | Capacitor, 100 $\mu$ F, 25 V, Electrolytic          | 124010-107 | Q5                   | Integrated Circuit, 7805   | 137596-001  |
| C5                         | Capacitor, 4700 $\mu$ F, 25 V, Electrolytic, Radial | 123021-478 | Q6                   | Transistor, 2N3906   | 133040-001  |
| C6                         | Capacitor, .1 $\mu$ F, 50 V, Ceramic                | 122002-104 | <b>Resistors</b>     |  |             |
| C7                         | Capacitor, 100 pF, 100 V, Ceramic                   | 122016-101 | R1                   | Resistor, 100 K $\Omega$ , $\pm 5\%$ , 1/4 W   | 110000-104  |
| C8                         | Capacitor, 100 $\mu$ F, 25 V, Electrolytic          | 124010-107 | R2                   | Resistor, 270 $\Omega$ , $\pm 5\%$ , 1/4 W   | 110000-271  |
| C9, C10                    | Capacitor, .1 $\mu$ F, 50 V, Ceramic                | 122002-104 | R5                   | Resistor, 1 K $\Omega$ , $\pm 5\%$ , 1/4 W   | 110000-102  |
| C13-C17                    | Capacitor, .1 $\mu$ F, 50 V, Ceramic                | 122002-104 | R6, R7               | Resistor, 510 $\Omega$ , $\pm 5\%$ , 1/4 W   | 110000-511  |
| C19                        | Capacitor, .1 $\mu$ F, 50 V, Ceramic                | 122002-104 | R8                   | Resistor, 10 K $\Omega$ , $\pm 5\%$ , 1/4 W  | 110000-103  |
| C18                        | Capacitor, 100 pF, 100 V, Ceramic                   | 122016-101 | R9                   | Resistor, 1 K $\Omega$ , $\pm 5\%$ , 1/4 W   | 110000-102  |
| C20, C21                   | Capacitor, 1000 $\mu$ F, 25 V, Electrolytic, Radial | 123003-108 | R10                  | Resistor, 2.2 K $\Omega$ , $\pm 5\%$ , 1/4 W   | 110000-222  |
| C22                        | Capacitor, 1 $\mu$ F, 50 V, Electrolytic            | 124001-105 | R11                  | Resistor, 100 $\Omega$ , $\pm 5\%$ , 20 W (Acceptable Substitute is part no. 116027-101) | 116025-101  |
| C23-C30,                   |   |            | R12                  | Resistor, 68 K $\Omega$ , $\pm 5\%$ , 1/4 W  | 110000-683  |
| C74                        | Capacitor, .1 $\mu$ F, 50 V, Ceramic                | 122002-104 | R13, R14             | Resistor, 10 K $\Omega$ , $\pm 5\%$ , 1/4 W  | 110000-103  |
| <b>Diodes</b>              |   |            | R19, R20             | Resistor, 1.2 K $\Omega$ , $\pm 5\%$ , 1/2 W   | 110001-122  |
| CR1                        | Diode, 1N4001                                       | 131048-001 | R21                  | Resistor, 22 K $\Omega$ , $\pm 5\%$ , 1/4 W  | 110000-223  |
| CR2                        | Diode, 1N5401                                       | 131051-002 | R22                  | Resistor, 2.2 K $\Omega$ , $\pm 5\%$ , 1/4 W   | 110000-222  |
| CR3                        | Diode, 1N4005                                       | 131048-005 | R23                  | Resistor, 4.7 K $\Omega$ , $\pm 5\%$ , 1/4 W   | 110000-472  |
| CR5                        | Diode, MV5053, Light-Emitting                       | 131027-002 | R24, R25             | Resistor, 3 K $\Omega$ , $\pm 5\%$ , 1/4 W   | 110000-302  |
| CR6                        | Diode, 1N100  | 131053-001 | R26                  | Resistor, 330 $\Omega$ , $\pm 5\%$ , 1/4 W   | 110000-331  |
| CR7                        | Diode, 1N4001                                       | 131048-001 | R27, R28             | Resistor, 4.7 $\Omega$ , 1 W   | 110030-047  |
| <b>Integrated Circuits</b> |   |            | R29, R30             | Resistor, 348 $\Omega$ , 1 W   | 110029-3480 |
| IC1, IC2                   | Integrated Circuit, 74LS163 A                       | 137114-001 | R31                  | Resistor, 1 K $\Omega$ , $\pm 5\%$ , 1/4 W   | 110000-102  |
| IC3                        | Integrated Circuit, 74HCT00                         | 137606-001 | R32                  | Resistor, 47 K $\Omega$ , $\pm 5\%$ , 1/4 W  | 110000-473  |
| IC4, IC5                   | Integrated Circuit, 74LS163 A                       | 137114-001 | R33                  | Resistor, 100 $\Omega$ , $\pm 5\%$ , 1/4 W   | 110000-101  |
| IC6                        | Integrated Circuit, 7414                            | 137017-001 | R34                  | Resistor, 39 K $\Omega$ , $\pm 5\%$ , 1/4 W  | 110000-393  |
| IC7                        | Integrated Circuit, 74LS374                         | 137144-001 | R35                  | Resistor, 2.2 $\Omega$ , $\pm 5\%$ , 1/4 W   | 110000-022  |
| IC8                        | Integrated Circuit, DAC-08                          | 137159-001 | R36                  | Resistor, 348 $\Omega$ , 1 W   | 110029-3480 |
| IC9                        | Integrated Circuit, 74LS374                         | 137144-001 | R37                  | Resistor, 2.7 K $\Omega$ , $\pm 5\%$ , 1/4 W   | 110000-272  |
| IC10                       | Integrated Circuit                                  | 137584-001 | R134                 | Resistor, 0 $\Omega$ , $\pm 5\%$ , 1/4 W   | 110005-001  |
| IC11                       | Integrated Circuit                                  | 137523-001 | <b>Miscellaneous</b> |  |             |
| IC12                       | Integrated Circuit, 74HCT00                         | 137606-001 | HS1                  | Heat Sink, TDA2030   | 178190-032  |
| L1                         | Inductor, 3.3 $\mu$ H                               | 141023-001 | JP1-3                | Connector, Rept, 2 Ckt   | 179178-002  |
| <b>Fuse</b>                |   |            | J1-J5                | Connector, 3 Circuit, Header, .156 Ctr   | 179213-003  |
| PTC1                       | Fuse, Current, PTC, .9 A, 50 V                      | 146011-090 | J6                   | Connector, 26 Circuit, Header, .1 X .1 Dual  | 179261-026  |
|                            |   |            | JP1-JP3              | Connector, 3 Ckt, Header, .100 Ctr   | 179048-003  |



**Figure 4-14 Brake PCB Assembly  
A044817-01 F**

### Brake PCB Assembly Parts List

| Designator                | Description                                 | Part No.   | Designator           | Description                                      | Part No.   |
|---------------------------|---|------------|----------------------|--|------------|
| <b>Capacitors</b>         |   |            | <b>Resistors</b>     |  |            |
| C1                        | Capacitor, 1000 $\mu$ F, 25 V, Electrolytic | 124009-108 | R1                   | Resistor, 10 $\Omega$ , $\pm 5\%$ , 1/4 W        | 110000-100 |
| C2, C3                    | Capacitor, .1 $\mu$ F, 50 V, Ceramic        | 122002-104 | R3                   | Resistor, 330 $\Omega$ , $\pm 5\%$ , 1/2 W       | 110001-331 |
| C4                        | Capacitor, 470 $\mu$ F, 25 V, Electrolytic  | 123009-477 | R4                   | Resistor, 1 K $\Omega$ , $\pm 5\%$ , 1/4 W       | 110000-102 |
| C5-C7                     | Capacitor, .1 $\mu$ F, 50 V, Ceramic        | 122002-104 | R5                   | Resistor, 2.2 M $\Omega$ , $\pm 5\%$ , 1/4 W     | 110000-225 |
| C8                        | Capacitor, 10 $\mu$ F, 20 V, Tantalum       | 127001-106 | R6                   | Resistor, 1 K $\Omega$ , $\pm 5\%$ , 1/4 W       | 110000-102 |
| C9                        | Capacitor, .001 $\mu$ F, 50 V, $\pm 10\%$   | 122015-102 | R7                   | Resistor, 10 K $\Omega$ , $\pm 5\%$ , 1/4 W      | 110000-103 |
| C10                       | Capacitor, .1 $\mu$ F, 50 V, Ceramic        | 122002-104 | R8                   | Resistor, 1 K $\Omega$ , $\pm 5\%$ , 1/4 W       | 110000-102 |
| <b>Diodes</b>             |   |            | R9                   | Resistor, 270 K $\Omega$ , $\pm 5\%$ , 1/4 W     | 110000-274 |
| CR1                       | Diode, 1N4740, 10 V, 5%, Zener              | 131009-213 | R10-R12              | Resistor, 1 K $\Omega$ , $\pm 5\%$ , 1/4 W       | 110000-102 |
| CR2                       | Diode, MV5053, Light-Emitting               | 131027-002 | <b>Miscellaneous</b> |  |            |
| <b>Integrated Circuit</b> |   |            | J1                   | Connector, 9 Circuit, Header,<br>.156 Ctr, Key 3 | 179213-009 |
| IC1                       | Integrated Circuit                          | 137576-002 |                      |  |            |
| <b>Transistor</b>         |   |            |                      |  |            |
| Q1                        | Integrated Circuit, 7812                    | 137597-001 |                      |  |            |

# N O T E S

# Race Drivin' Statistics Sheet

Location: \_\_\_\_\_ Date Recorded: \_\_\_\_\_  
 Meter: \_\_\_\_\_

## STATISTICS INFORMATION

|                    |       |                           |           |       |                          |           |       |
|--------------------|-------|---------------------------|-----------|-------|--------------------------|-----------|-------|
| Left Coins: _____  | _____ | _____                     | _____     | _____ | _____                    | _____     | _____ |
| Right Coins: _____ | _____ | Original                  | Autocross | Super | Original                 | Autocross | Super |
| Aux Coins: _____   | _____ | Laps by Track:            | _____     | Stunt | Free Games by Track:     | _____     | Stunt |
| Idle Min: _____    | _____ | _____                     | _____     | _____ | _____                    | _____     | _____ |
| Active Min: _____  | _____ | No X Games by Track:      | _____     | _____ | Total Games by Track:    | _____     | _____ |
| Auto Games: _____  | _____ | _____                     | _____     | _____ | _____                    | _____     | _____ |
| Error Count: _____ | _____ | 1 X Play Games by Track:  | _____     | _____ | Total Time by Track:     | _____     | _____ |
| Total Games: _____ | _____ | _____                     | _____     | _____ | _____                    | _____     | _____ |
|                    |       | 2 X Play Games by Track:  | _____     | _____ | Avg Time by Track (sec): | _____     | _____ |
|                    |       | _____                     | _____     | _____ | _____                    | _____     | _____ |
|                    |       | 3+ X Play Games by Track: | _____     | _____ | Games by Car:            | _____     | _____ |
|                    |       | _____                     | _____     | _____ | _____                    | _____     | _____ |
|                    |       | Champ Laps by Track:      | _____     | _____ | _____                    | _____     | _____ |
|                    |       | _____                     | _____     | _____ | _____                    | _____     | _____ |
|                    |       | 2 Player Games by Track:  | _____     | _____ | Inst Rpls:               | _____     | _____ |
|                    |       | _____                     | _____     | _____ | Rpl Abns:                | _____     | _____ |
|                    |       | 2 Player Time by Track:   | _____     | _____ | Rpl Secs:                | _____     | _____ |
|                    |       | _____                     | _____     | _____ | Total Credits:           | _____     | _____ |
|                    |       | _____                     | _____     | _____ | Avg Time/Credit:         | _____     | _____ |

## HISTOGRAM INFORMATION

| Time    | No. of Games | Time    | No. of Games | Time    | No. of Games | Time     | No. of Games |
|---------|--------------|---------|--------------|---------|--------------|----------|--------------|
| 0-99    | _____        | 180-199 | _____        | 280-299 | _____        | 380-399  | _____        |
| 100-119 | _____        | 200-219 | _____        | 300-319 | _____        | 400-419  | _____        |
| 120-139 | _____        | 220-239 | _____        | 320-339 | _____        | 420-439  | _____        |
| 140-159 | _____        | 240-259 | _____        | 340-359 | _____        | 440-459  | _____        |
| 160-179 | _____        | 260-279 | _____        | 360-379 | _____        | 460 & UP | _____        |

## ERROR COUNTS

|                     |       |                       |       |
|---------------------|-------|-----------------------|-------|
| Watch Dog Resets    | _____ | Bad Poly Buff Error   | _____ |
| Bus Error           | _____ | MSP Timeout Error     | _____ |
| Address Error       | _____ | ADSP Timeout Error    | _____ |
| Illegal Inst Error  | _____ | GSP Timeout Error     | _____ |
| Divide by Zero Err  | _____ | Generic Error         | _____ |
| Chk Inst Error      | _____ | NMI Error             | _____ |
| Trap Error          | _____ | Spur Exptn Error      | _____ |
| Piv Vio Error       | _____ | ASIC 65 Timeout Error | _____ |
| GSP Handshake Error | _____ | Illegal Error Code    | _____ |



# Warranty

Seller warrants that its printed-circuit boards and parts thereon are free from defects in material and workmanship under normal use and service for a period of ninety (90) days from date of shipment. Seller warrants that its video displays and laser-video disc players (in games supplied with displays and video-disc players) are free from defects in material and workmanship under normal use and service for a period of thirty (30) days from date of shipment. None of the Seller's other products or parts thereof are warranted.

If the products described in this manual fail to conform to this warranty, Seller's sole liability shall be, at its option, to repair, replace, or credit Buyer's account for such products which are returned to Seller during said warranty period, provided:

- (a) Seller is promptly notified in writing upon discovery by Buyer that said products are defective;
- (b) Such products are returned prepaid to Seller's plant; and
- (c) Seller's examination of said products discloses to Seller's satisfaction that such alleged defects existed and were not caused by accident, misuse, neglect, alteration, improper repair, installation, or improper testing.

In no event shall Seller be liable for loss of profits, loss of use, incidental or consequential damages.

*Except for any express warranty set forth in a written contract between Seller and Buyer which contract supersedes the terms herein, this warranty is expressed in lieu of all other warranties expressed or implied, including the implied warranties of merchantability and fitness for a particular purpose, and of all other obligations or liabilities on the Seller's part, and it neither assumes nor authorizes any other person to assume for the Seller any other liabilities in connection with the sale of products by Seller.*

The use of any non-Atari parts may void your warranty, according to the terms of the warranty. The use of any non-Atari parts may also adversely affect the safety of your game and cause injury to you and others. Be very cautious in using non-Atari-supplied components with our games, in order to ensure your safety.

Atari distributors are independent, being privately owned and operated. In their judgment they may sell parts or accessories other than Atari parts or accessories. Atari Games Corporation cannot be responsible for the quality, suitability or safety of any non-Atari part or any modification including labor which is performed by such distributor.



**Atari Games Corporation**

675 Sycamore Drive

P.O. Box 361110

Milpitas, CA 95036

