



OPERATION MANUAL

**25" VIDEO GAME
DEDICATED CABINET
CONVERSION INSTRUCTIONS
FOR
SPORTS SHOOTING USA**

 **Sammy USA Corporation**

901 CAMBRIDGE DRIVE
ELK GROVE VILLAGE, IL 60007
TEL: (847)364-9787 FAX: (847)364-9831
TOLL-FREE: 1-888-US-SAMMY
WWW.SAMMYUSA.COM

Part#:69-30-300

CONTENTS

1.	SPECIFICATIONS OF CABINET.....	2,3
2.	GAME PLAY.....	4
3.	GAME SETTING.....	5
4.	CALIBRATION OF GUN	6
5.	SYSTEM BOARD	7 to 11
	EXPANSION CARTRIDGE SLOT 1.....	7
	JAMMA CONNECTOR TABLE	8
	SPEAKER VOLUME (SOUND)	9
	MODEM CONNECTOR (SRL) >>> OPTION	9
	DIP SWITCH (2 POSITIONS)	9
	STEREO SPEAKER OUTPUT CONNECTOR (OPTION)	10
	VGA (31KHz) TV SIGNAL OUTPUT CONNECTOR (VDO) >>> OPTION ...	10
	GAME CARTRIDGE	11
6.	SYSTEM MENU	12 to 18
	TEST MODE	13, 14
	COIN SETTING	15, 16
	CONFIGURATION	17
	BOOKKEEPING	18
	BACKUP CLEAR	19
	WARRANTY	
	GUN SUB HARNESS (FOR KIT) WIRING DIAGRAM	
	GUN CONTROL PANEL (DEDICATED) WIRING DIAGRAM	
	CONVERSION INSTRUCTIONS (FROM SPORTS SHOOTING USA)	
	CABINET WIRING DIAGRAM	

1. SPECIFICATIONS OF CABINET

INPUT POWER: USA&CANADA = 120VAC, 60Hz

SIZE: W = 30" (762 mm)

WEIGHT: 380 lbs (173 kg)

D = 37" (940 mm)

H = 75" (1910 mm)



INSIDE VIEW OF CONTROL PANEL & INSTRUCTION PANEL

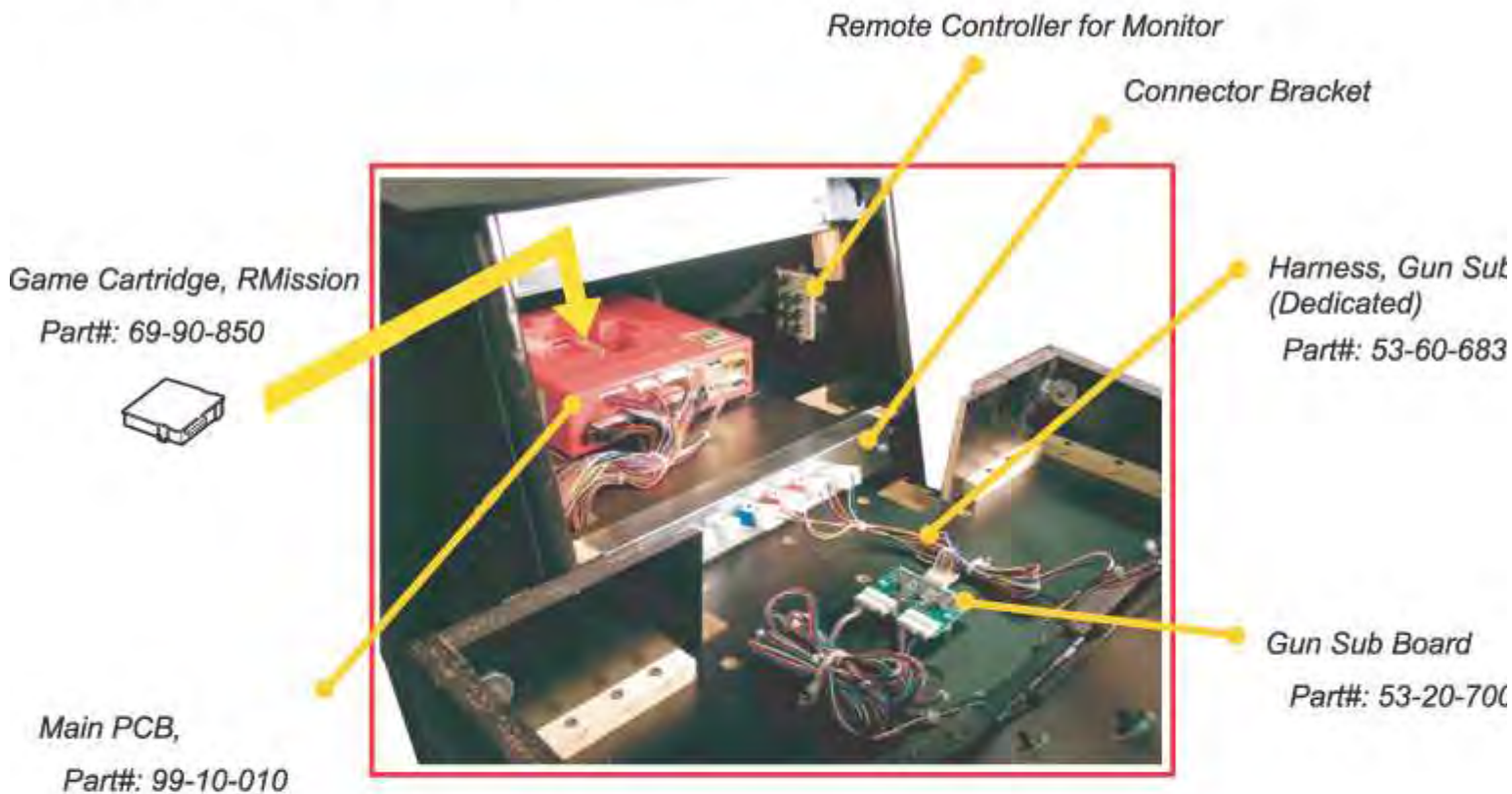

INSIDE VIEW OF COIN DOOR

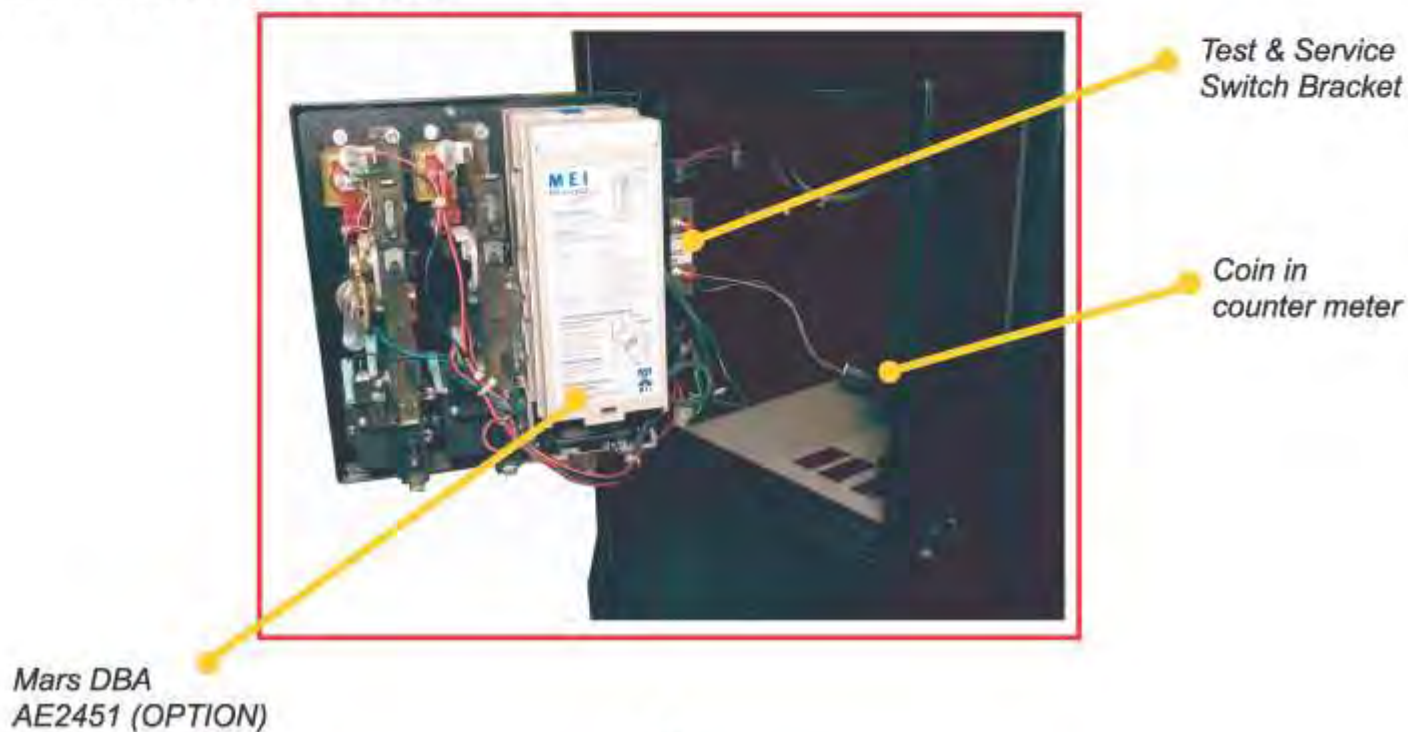

2. GAME PLAY

Insert coin(s).

Shoot using Shotgun to select one of SIMULATION STAGE from 4 kinds.

STAGE 1: OPERATION "JAGUAR" (Jungle mission)

STAGE 2: OPERATION "INDOMITABLE WILL" (Indoor rescue mission)

STAGE 3: OPERATION "BLIZZARD" (Tundra mission)

STAGE 4: OPERATION "DESERT FALCON" (Desert mission)

Each stage has 5 missions. Each mission has different weapons, regulations and orders.

OBJECT:

Clear all 5 missions. Get all "A"s to go to BONUS.



Weapon, STAGE 1

Mission 1: Assault Rifle

Mission 2: Sniper Rifle

Mission 3: Sub Machine gun

Mission 4: Shot gun

Mission 5: Rocket Launcher

Weapon, STAGE 2

Mission 1: Hand Grenade

Mission 2: Assault Rifle

Mission 3: Sub machine gun

Mission 4: Sniper Rifle

Mission 5: Assault Rifle

Weapon, STAGE 3

Mission 1: Sniper Rifle

Mission 2: Shot gun

Mission 3: Hellfire missile

Mission 4: Sub Machine gun

Mission 5: Rocket Launcher

Weapon, STAGE 4

Mission 1: Assault Rifle

Mission 2: Machine gun

Mission 3: Machine gun

Mission 4: Shot gun

Mission 5: Machine gun

Register your initials when you rank in top 15.



**SHOOT EACH ENEMY
TARGET!**



**DON'T SHOOT
HOSTAGES!**

3. GAME SETTING

Ranger Mission has dedicated GAME SETTINGS. Press TEST switch to display "SYSTEM MENU" screen. Go to "CONFIGURATION" and Select "GAME SETTING." You can adjust following game settings:

■ MY LIFE

3 kinds. (1, 2 or 3) Lose one LIFE when player does not qualify in each stage. Default is 2.

■ DIFFICULTY (Qualifying points and time adjustment)

4 kinds. (NOVICE, ADVANCED, EXPERT and PRO) Default is **ADVANCED**

■ CONTINUE

2 kinds. (ON or OFF) Default is **ON**.

■ RELOAD TYPE

7 kinds. Default is **SHOTGUN & HANDGUN**.

SHOTGUN >>> Pump to reload.

AUTO >>> Reload automatically when magazine is empty.

SHOTGUN & AUTO >>> Pump to reload, also reload automatically when magazine is empty.

HAND GUN >>> Shoot off the screen to reload.

SHOTGUN & HANDGUN >>> Pump or shoot off the screen to reload.

AUTO & HANDGUN >>> Reload automatically when magazine is empty or shoot off the screen to reload.

SHOTGUN & AUTO & HANDGUN >>> Reload using Pump, shoot off the screen and automatically.

■ RELOAD TIME

3 kinds. (0, 0.25 and 0.5 seconds.) Default is 0 **SECOND**.



COIN SETTING: OUR RECOMMENDATION for RANGER MISSION (NORTH AMERICAN VERSION)

GAME MODE: NORMAL

COIN CHUTE TYPE: COMMON

PLAYER MODE: 2 PLAYERS

COIN CHUTE #A: **3** COINS 1 CREDIT, **2** COINS CONTINUE

COIN CHUTE #B: **3** COINS 1 CREDIT, **2** COINS CONTINUE

PRESET SITUATION: NORMAL

4. CALIBRATION OF GUN ASSY

For gun calibration, go to "TEST MENU" and select "I/O TEST." Screen shows calibration screen. (Fig.1)

Bottom of screen shows "SHOOT CENTER MARK ONLY ADJUST." (Fig.1)

Shoot center of X mark by using 1 player and 2 player guns.

Then Press SERVICE switch to go to GUN TEST screen. (Fig.2)

Pull the trigger to test both guns at this mode. Screen shows X marks when pull the trigger. Shoot anywhere to test gun calibration at this screen.

Before Pulling trigger at this screen, please test all of switches, if necessary. Screen shows ON or OFF letters for each switch when they are activated.

After finished with above, press SERVICE switch to exit I/O test. Please double check gun calibration using normal game mode. Move gun forward and backward then shoot screen. Make sure each gun's hit mark does not move or jump.

If hit mark moves or jumps, you need monitor adjustment. Lower brightness or contrast of monitor.

NOTE: Once you are in this mode, you can not skip calibration of both guns. If you re-power game during calibration, all settings will revert to previous data.

Fig.1

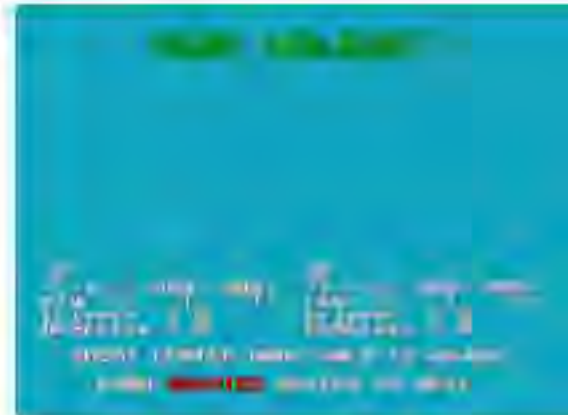

Fig.2



5. SYSTEM BOARD

DIMENSIONS: 10.67" W x 9.04" D x 2.52" H

WEIGHT: 3 lbs

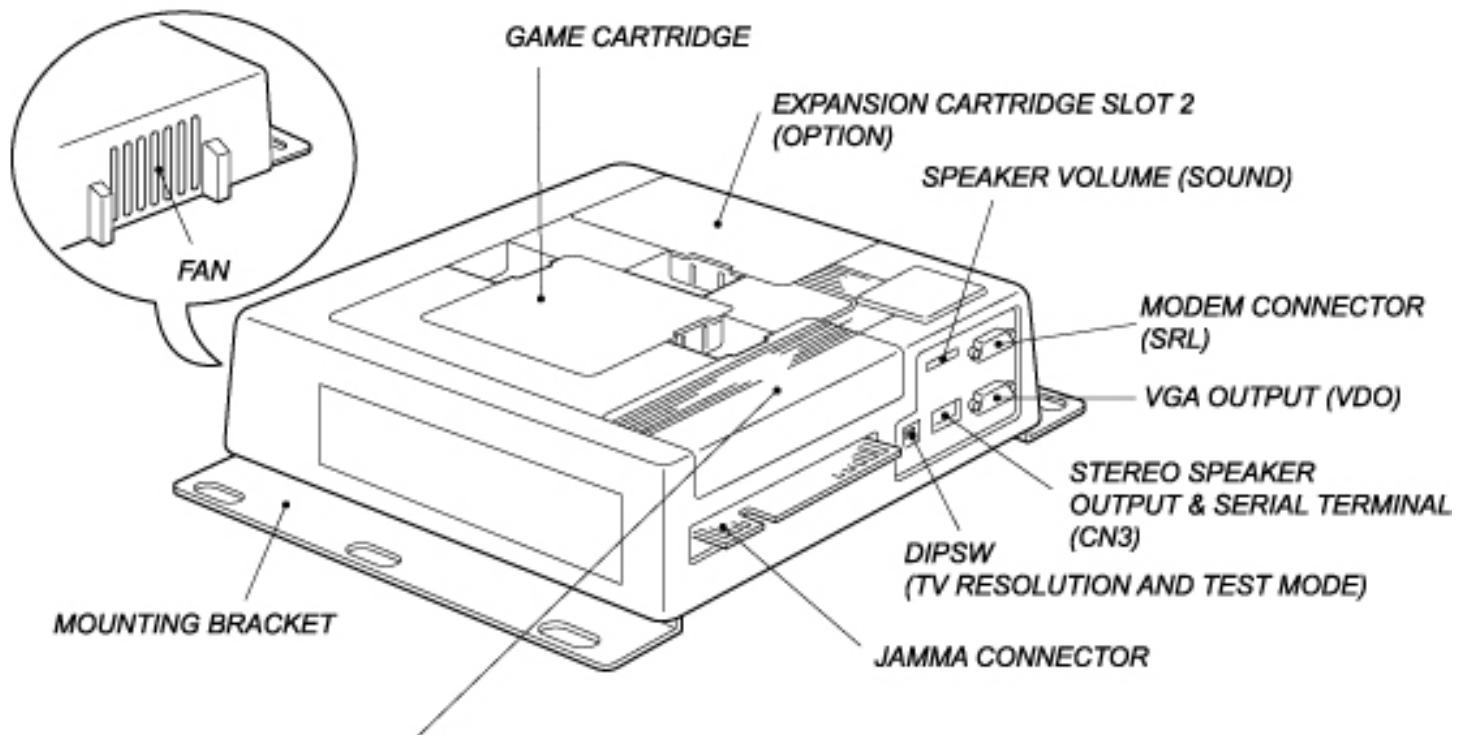

■ EXPANSION CARTRIDGE SLOT 1 (EX. I/O BOARD) CONNECTOR TABLE

CN303: 8 PIN CONNECTOR

PIN#	FUNCTION
1	+5VDC
2	+5VDC
3	GND
4	GND
5	ANALOG 0
6	ANALOG 1
7	ANALOG 2
8	ANALOG 3

CN304: 12 PIN CONNECTOR

PIN#	FUNCTION
1	+5VDC
2	+5VDC
3	GND
4	GND
5	POUT 0
6	POUT 1
7	POUT 2
8	POUT 3
9	POUT 4
10	POUT 5
11	POUT 6
12	POUT 7

CN302: 28 PIN CONNECTOR

PIN#	FUNCTION	PIN#	FUNCTION
1	+5VDC	2	+5VDC
3	GND	4	GND
5	3P GUN	6	4P GUN
7	3PUP/PULX1	8	4PUP/PULX1
9	3PDO/PULX2	10	4PDO/PULX2
11	3PLE/PULY1	12	4PLE/PULY1
13	3PRI/PULY2	14	4PRI/PULY2
15	3P COIN	16	4P COIN
17	3P START	18	4P START
19	3PPU1/TRIG	20	4PPU1/TRIG
21	3P PUSH2	22	4P PUSH2
23	3P PUSH3	24	4P PUSH3
25	3P PUSH4	26	4P PUSH4
27	3P PUSH5	28	4P PUSH5

■ JAMMA CONNECTOR TABLE

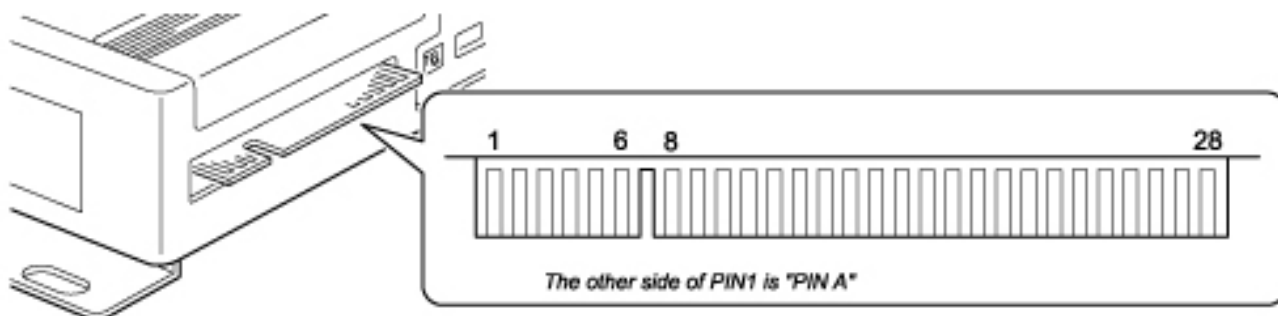

JAMMA EDGE CONNECTOR (56 PINS)

No.	FUNCTION	I/O	No.	FUNCTION	I/O
1	GND	-	A	GND	-
2	GND	-	B	GND	-
3	+5V	IN	C	+5V	IN
4	+5V	IN	D	+5V	IN
5	N.C.	-	E	N.C.	-
6	+12V	IN	F	+12V	IN
7	N.C.	-	H	N.C.	-
8	1P COIN COUNTER	OUT	J	2P COIN COUNTER	OUT
9	1P COIN LOCKOUT	OUT	K	2P COIN LOCKOUT	OUT
10	MONO SPEAKER (+)	OUT	L	MONO SPEAKER (-)	OUT
11	AUDIO OUT	OUT	M	AUDIO GND	-
12	VIDEO RED	OUT	N	VIDEO GREEN	OUT
13	VIDEO BLUE	OUT	P	VIDEO SYNC	OUT
14	VIDEO GND	-	R	SERVICE SW	IN
15	TEST SW	IN	S	TILT SW	IN
16	1P COIN	IN	T	2P COIN	IN
17	1P START	IN	U	2P START	IN
18	NOT USED	IN	V	NOT USED	IN
19	NOT USED	IN	W	NOT USED	IN
20	NOT USED	IN	X	NOT USED	IN
21	NOT USED	IN	Y	NOT USED	IN
22	1P PUMP	IN	Z	2P PUMP	IN
23	NOT USED	IN	a	NOT USED	IN
24	NOT USED	IN	b	NOT USED	IN
25	NOT USED	IN	c	NOT USED	IN
26	NOT USED	IN	d	NOT USED	IN
27	GND	-	e	GND	-
28	GND	-	f	GND	-

■ **SPEAKER VOLUME (SOUND)**

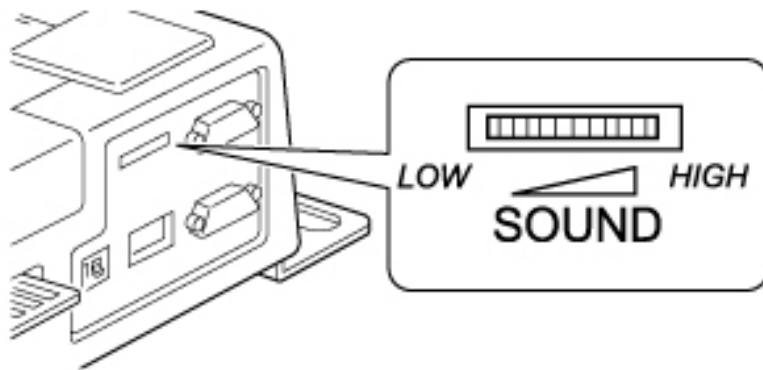

Use for adjusting game sound

■ **MODEM CONNECTOR (SRL) >>> OPTION**

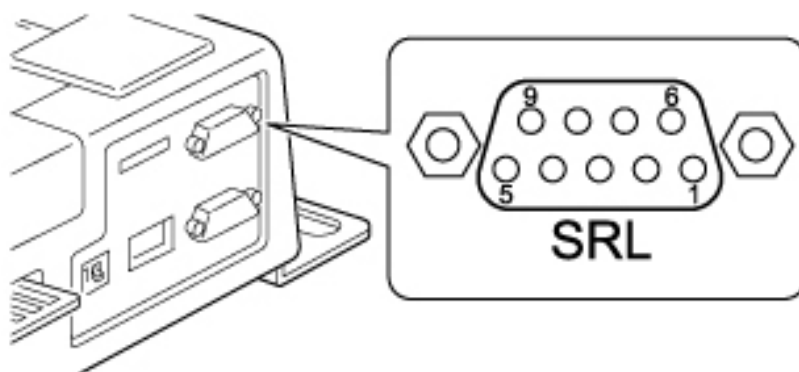

JST 9PIN SUB, CONNECTOR (MALE)

No.	FUNCTION	I/O
1	(N.C.)	-
2	RXD2	IN
3	TXD2	OUT
4	DTR	OUT
5	GND	-
6	(N.C.)	-
7	RTS	OUT
8	CTS	IN
9	(N.C.)	-

■ **DIP SWITCH (2 POSITIONS)**

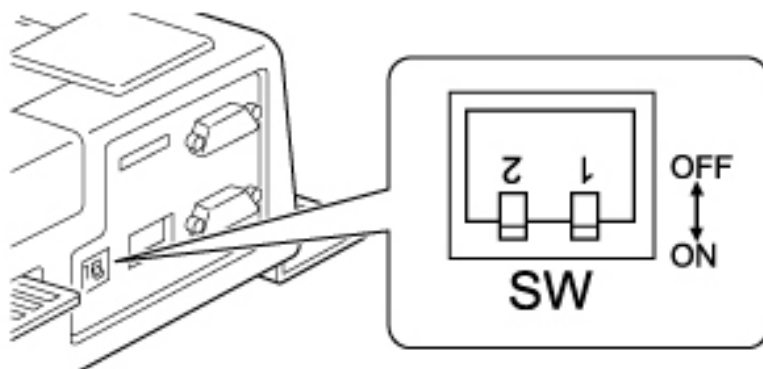

SW-1: Change Frequency of TV signal.
Default is OFF = 15KHz*
*For Standard = Low resolution monitor

SW-2: Change ON position to go to SYSTEM MENU.

	ON	OFF
SW-1	31KHZ	15KHZ
SW-2	SYSTEM MENU MODE	GAME MODE

■ STEREO SPEAKER OUTPUT CONNECTOR (OPTION)

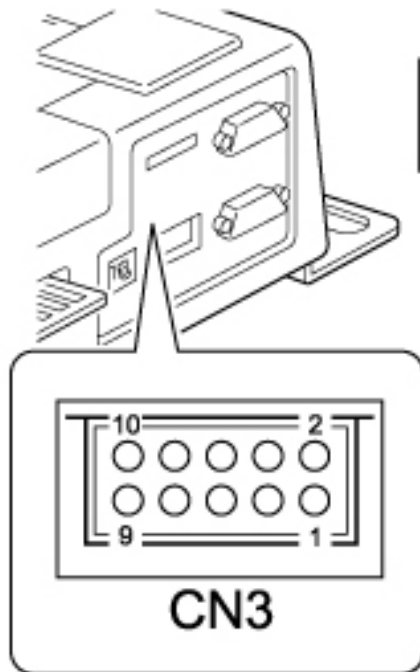

NOTE:

Can not use JAMMA speaker output & STEREO speaker output at same time.

STEREO SPEAKER OUTPUT & EXTENSION SERIAL CONNECTOR, PIN LAYOUT
(JST, 10 PIN PHD CONNECTOR)

No.	FUNCTION	I/O	No.	FUNCTION	I/O
1	STEREO SPEAKER L (+)	OUT	2	TXD	OUT
3	STEREO SPEAKER L (-)	OUT	4	RXD	IN
5	STEREO SPEAKER R (+)	OUT	6	GND	-
7	STEREO SPEAKER R (-)	OUT	8	+5V	OUT
9	N.C.	-	10	N.C.	-

■ VGA (31KHz) TV SIGNAL OUTPUT CONNECTOR (VDO) >>>OPTION

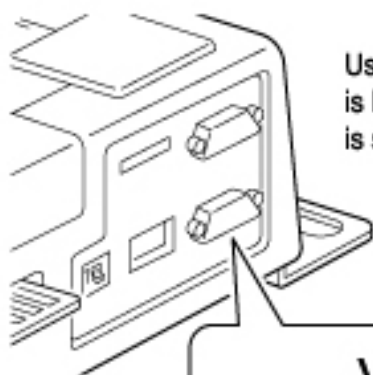

Use this connector when TV Monitor is High Resolution. Make sure DIPSW #1 is set to ON position.

VGA OUTPUT CONNECTOR, PIN LAYOUT
(JST, 15 PIN D-SUB CONNECTOR, 3 SEQUENCE, FEMALE)

No.	FUNCTION	I/O
1	R	OUT
2	G	OUT
3	B	OUT
4	N.C.	-
5	GND	-
6	R-GND	-
7	G-GND	-
8	B-GND	-
9	+5V	OUT
10	GND	-
11	N.C.	-
12	N.C.	-
13	COMP SYNC	OUT
14	N.C.	-
15	N.C.	-

■ GAME CARTRIDGE

HOW TO MOUNT GAME CARTRIDGE

*Check position of connector for both game cartridge and slot in MAIN PCB.
Then insert Game Cartridge.
Make sure that Game Cartridge is locked by hooks.*

HOW TO REMOVE GAME CARTRIDGE

*Pinch both Hooks on game cartridge,
then pull game cartridge out.*

*When you exchange Game Cartridge to
another Game Cartridge, all backup data
(bookkeeping data) will be cleared. Then
all settings will go back to default settings.*

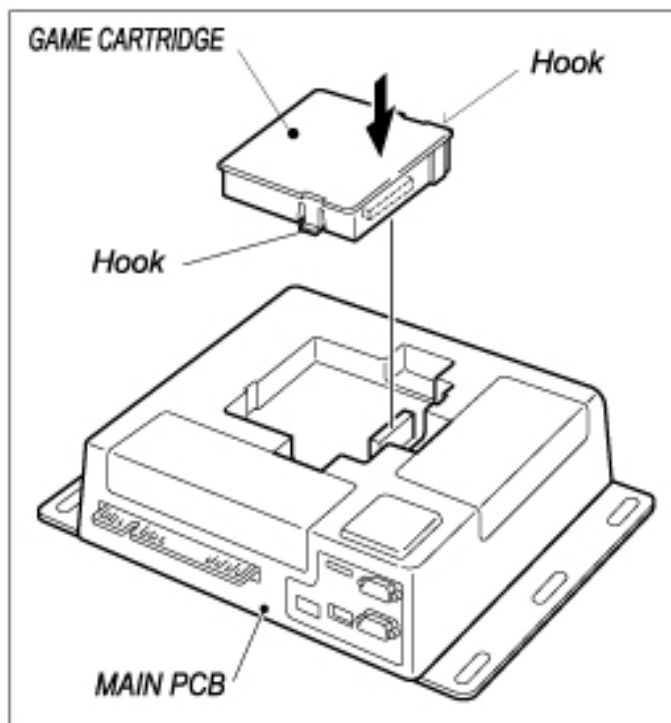

6. SYSTEM MENU

Press TEST switch to enter SYSTEM MENU.

(TEST switch can be activated any time. Game play will cancel when you press a test switch during game play. Credit(s) will be lost.)

FLOW CHART

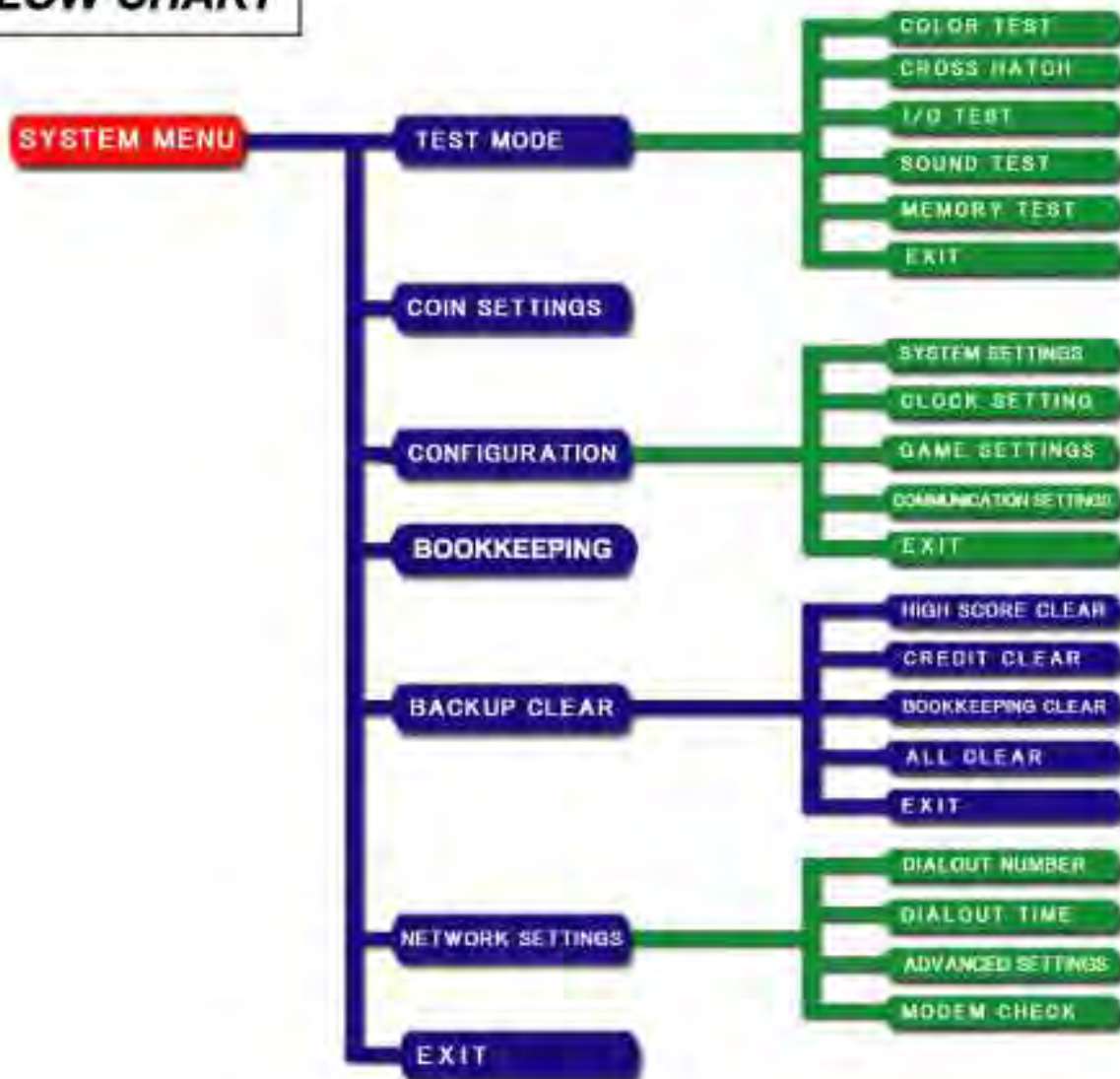

HOW TO CONTROL

Press TEST switch to move cursor. Press SERVICE switch to select.

(If there is no TEST switch in your cabinet, change DIPSW #2 ON, re-power on to go to SYSTEM MENU. Press 1P START switch quickly to move cursor. Press & hold 1P START button to select it.)

TOP PAGE OF SYSTEM MENU

This is first screen of SYSTEM MENU.

Move cursor to contents then select to go to next menu

*Move cursor to "EXIT" and select to go back to normal game mode.
Credit(s) are memorized.*



TEST MODE

Use for function test of game.

Select "EXIT" to go back to top page screen of SYSTEM MENU.



COLOR TEST

Use for Color adjustment and checking of monitor.

Press SERVICE switch to go back to TEST MODE screen



CROSS HATCH

Use for Size adjustment of monitor.

Press SERVICE switch to go back to TEST MODE screen



I/O TEST

Use for Gun Calibration. Refer page 6 of "GUN CALIBRATION OF GUN ASSY"

SOUND TEST

*Use for checking Speaker output.
When NOT STEREO SPEAKER Setting,
select START to output sound.
Select STOP to stop sound.
Select "EXIT" to go back to
TEST MODE screen*

*When STEREO SPEAKER Setting (OPTION),
select RIGHT to output sound from right
speaker.
Select LEFT to output sound from left speaker.
Select CENTER to output sound from both left
& right speakers.
Select STOP to stop sound.
Select "EXIT" to go back to
TEST MODE screen*

MEMORY TEST

*Use for testing RAM of MAIN PCB.
Press TEST switch to start read
& writing RAM test. Can not cancel
this test till MEMORY test is complete.
Press SERVICE switch after
test complete to go back to
TEST MODE screen*



COIN SETTING

WARNING: ALL CREDIT DATA WILL BE LOST WHEN MAKING THE FOLLOWING CHANGES!

GAME MODE

Select **FREE PLAY** or **NORMAL**. Move cursor to **GAME MODE** then press **SERVICE** switch to select "**NORMAL (COIN OPERATION)**" or "**FREE PLAY.**"
(Refer Fig.B and C)

COIN CHUTE TYPE

Select **COMMON** or **INDIVIDUAL**. Move cursor to **COIN CHUTE TYPE** then press **SERVICE** switch to select "**COMMON**" or "**INDIVIDUAL**" mode.
(Refer Fig.A and B)



Fig. A



Fig. B

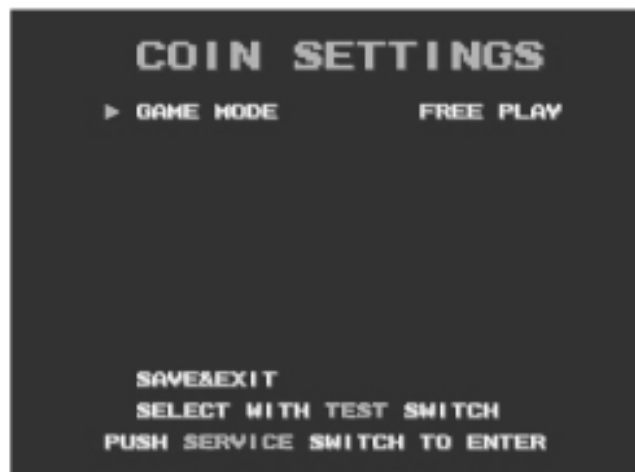

Fig. C

WHEN COIN CHUTE TYPE IS "COMMON"

Credit(s) will display all in one place on screen. Move cursor to coin chute A or B then press **SERVICE** switch to change setting number. Able to set up coin chute A and B separately.
Select **SAVE & EXIT** to go back to **SYSTEM MENU**.

WHEN COIN CHUTE TYPE IS "INDIVIDUAL"

Credit(s) will display on screen by players. Move cursor to coin chute A or B then press **SERVICE** switch to change setting number. Unable to set up coin chute A and B separately. Coin chute A & B will be same setting. Select **SAVE & EXIT** to go back to **SYSTEM MENU**.

PRESET SITUATION

There is 53 kinds of coin settings.
 When PRESET SITUATION is NORMAL,
 you can select from 14 kinds. (#00 to #09 and
 #45 to #48.) This is basic coin settings line-up.
 When PRESET SITUATION is ADVANCE,
 you can choose from all 53 kinds as shown
 below.

NO	COIN SETTING
#00	1 COIN 1 CREDIT / 1 COIN CONTINUE
#01	2 COINS 1 CREDIT / 1 COIN CONTINUE
#02	2 COINS 1 CREDIT / 2 COINS CONTINUE
#03	3 COINS 1 CREDIT / 1 COIN CONTINUE
#04	3 COINS 1 CREDIT / 2 COINS CONTINUE
#05	3 COINS 1 CREDIT / 3 COINS CONTINUE
#06	4 COINS 1 CREDIT / 1 COIN CONTINUE
#07	4 COINS 1 CREDIT / 2 COINS CONTINUE
#08	4 COINS 1 CREDIT / 3 COINS CONTINUE
#09	4 COINS 1 CREDIT / 4 COINS CONTINUE
#10	5 COINS 1 CREDIT / 1 COIN CONTINUE
#11	5 COINS 1 CREDIT / 2 COINS CONTINUE
#12	5 COINS 1 CREDIT / 3 COINS CONTINUE
#13	5 COINS 1 CREDIT / 4 COINS CONTINUE
#14	5 COINS 1 CREDIT / 5 COINS CONTINUE
#15	6 COINS 1 CREDIT / 1 COIN CONTINUE
#16	6 COINS 1 CREDIT / 2 COINS CONTINUE
#17	6 COINS 1 CREDIT / 3 COINS CONTINUE
#18	6 COINS 1 CREDIT / 4 COINS CONTINUE
#19	6 COINS 1 CREDIT / 5 COINS CONTINUE
#20	6 COINS 1 CREDIT / 6 COINS CONTINUE
#21	7 COINS 1 CREDIT / 1 COIN CONTINUE
#22	7 COINS 1 CREDIT / 2 COINS CONTINUE
#23	7 COINS 1 CREDIT / 3 COINS CONTINUE
#24	7 COINS 1 CREDIT / 4 COINS CONTINUE
#25	7 COINS 1 CREDIT / 5 COINS CONTINUE
#26	7 COINS 1 CREDIT / 6 COINS CONTINUE
#27	7 COINS 1 CREDIT / 7 COINS CONTINUE



NO	COIN SETTING
#28	8 COINS 1 CREDIT / 1 COIN CONTINUE
#29	8 COINS 1 CREDIT / 2 COINS CONTINUE
#30	8 COINS 1 CREDIT / 3 COINS CONTINUE
#31	8 COINS 1 CREDIT / 4 COINS CONTINUE
#32	8 COINS 1 CREDIT / 5 COINS CONTINUE
#33	8 COINS 1 CREDIT / 6 COINS CONTINUE
#34	8 COINS 1 CREDIT / 7 COINS CONTINUE
#35	8 COINS 1 CREDIT / 8 COINS CONTINUE
#36	9 COINS 1 CREDIT / 1 COIN CONTINUE
#37	9 COINS 1 CREDIT / 2 COINS CONTINUE
#38	9 COINS 1 CREDIT / 3 COINS CONTINUE
#39	9 COINS 1 CREDIT / 4 COINS CONTINUE
#40	9 COINS 1 CREDIT / 5 COINS CONTINUE
#41	9 COINS 1 CREDIT / 6 COINS CONTINUE
#42	9 COINS 1 CREDIT / 7 COINS CONTINUE
#43	9 COINS 1 CREDIT / 8 COINS CONTINUE
#44	9 COINS 1 CREDIT / 9 COINS CONTINUE
#45	1 COIN 2 CREDITS
#46	1 COIN 3 CREDITS
#47	1 COIN 4 CREDITS
#48	1 COIN 5 CREDITS
#49	1 COIN 6 CREDITS
#50	1 COIN 7 CREDITS
#51	1 COIN 8 CREDITS
#52	1 COIN 9 CREDITS

CONFIGURATION

4 kinds of contents.

Contents of "COMMUNICATION" is unavailable when game has no COMMUNICATION feature.

SYSTEM SETTINGS

AREA: Select country of operation.
(JAPAN, NORTH AMERICA, EUROPE or OTHER)
This setting effects factory defaults.

LANGUAGE: Select from following:
(English or Japanese)

ADVERTISE SOUND:
Select to output sound in attract mode.

AUDIO MODE:
Select sound STEREO (OPTION) or NORMAL

SOUND VOLUME:
Volume level of sound. Default is "15"

CLOCK SETTING

Adjust clock system on Main PCB.
Move cursor then press SERVICE switch to advance each digit. Press & hold SERVICE switch more than 1 sec. to speed it up.

Move cursor to "SAVE & EXIT" then press SERVICE switch to go back to SYSTEM MENU screen.

GAME SETTING

Adjust game setting at this mode.
Move cursor to "SAVE & EXIT" then press SERVICE switch to go back to CONFIGURATION.
Select "RETURN TO FACTORY SETTINGS" to change all settings to Factory default settings.



BACKUP CLEAR

*Clear following data in MAIN PCB.
(HIGH SCORE, CREDIT CLEAR,
BOOKKEEPING CLEAR and ALL CLEAR)*

*Press SERVICE to select each contents then
go to each data clear screen.*

*In each data clear screen, Press TEST switch
to move cursor to "YES" then press
SERVICE switch. After finishing data clear,
screen will go back to BACKUP CLEAR screen.*



WARRANTY

Limited warranty, Repair and Return Policy

Sammy USA Corporation warrants all products to be free from defective materials and workmanship for a period of thirty (30) days from the Sammy USA Corporation invoice date unless otherwise specified in writing by Sammy USA Corporation. The extent of this warranty applies to all electronic assemblies only, and does not include lamps and fuses.

This limited warranty is invalid for any product that upon examination, is deemed to have been subject to misuse, improper repair or installation, neglect or violation of specification or other instructions published by Sammy USA Corporation.

There are no additional warranties described above.

The limited warranties described above shall be in lieu of any other warranty, express or implied, including but not limited to any implied warranty of merchantability or fitness for a particular purpose.

Return Merchandise Authorization

- 1. Contact your authorized Sammy USA distributor to receive a Return Merchandise Authorization for return.*
- 2. You must obtain RMA numbers from Sammy USA Corporation through an authorized Sammy USA distributor. Please have your serial number available when calling for RMA number.*
- 3. All items must have an RMA number marked clearly on the outside of the package.*
- 4. Products must be shipped prepaid. Products returned without an RMA number will not be accepted.*
- 5. Credits to accounts are subject to inspection of products for damage and suitability for resale.*

Gun Sub Harness (For KIT), AW

NOTE: Please wire these 2 wires to your JAMMA connector when you use SAMMY 27" PUMP SHOT GUN.

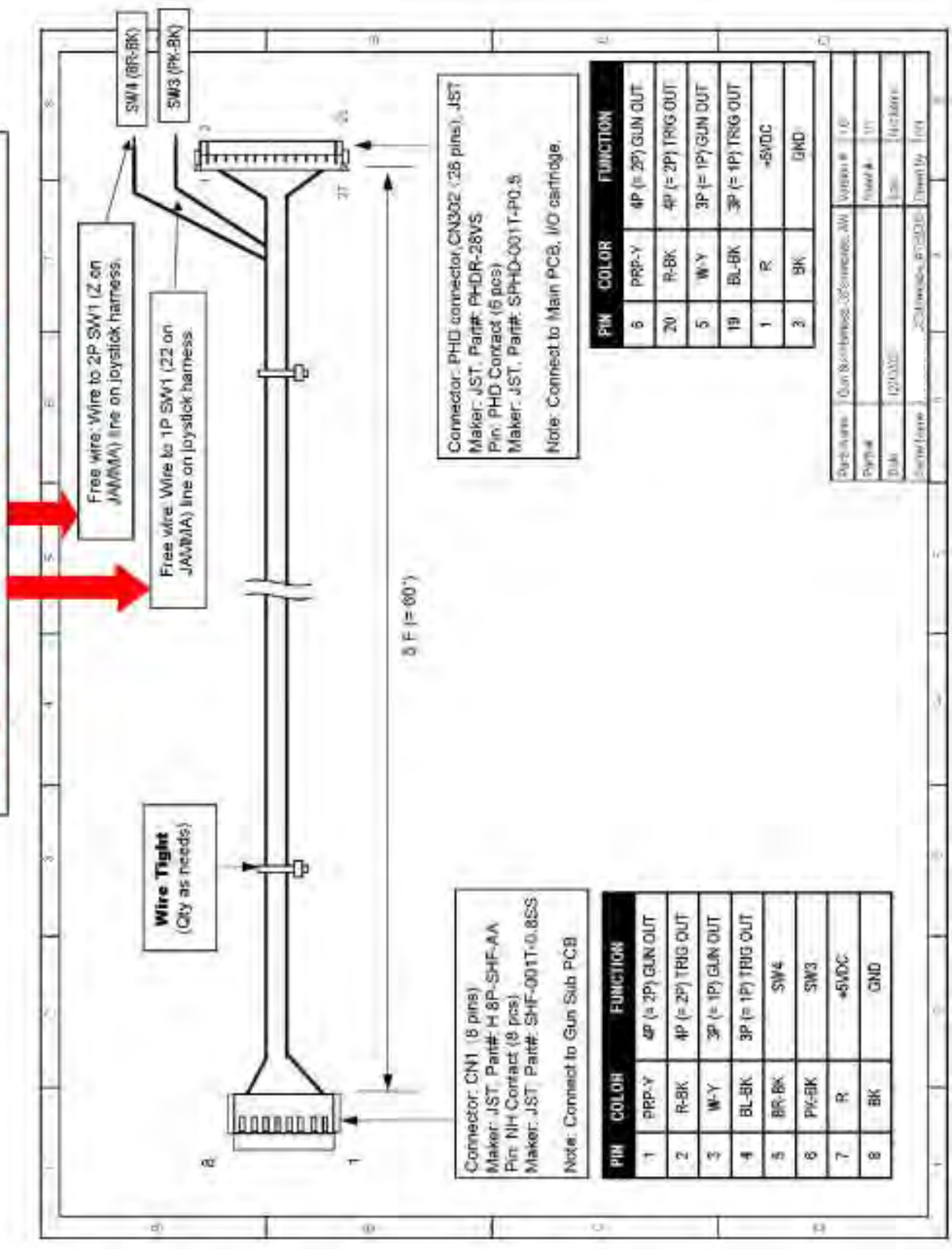



RANGER MISSION KIT for AW25"UR , SS USA

CONVERSION INSTRUCTION FROM SPORTS SHOOTING USA, AW25"UR

KEY PAD, GAME CARTRIDGE AND INSTRUCTION SHEET EXCHANGE



1) Open Coin door and unlatch control panel key pad.

2) Remove Scope Gun Assy from Key pad then mount 2 of Sammy 27" Shotgun Assy in its place.



3) Use carriage bolts to mount Holster Hook to each side of cabinet. Do not remove original Scope gun holster. Remove the inner Rubber spacer from both of Scope gun holster

Hook Holster

Scope Gun Holster

Do not remove this Rubber Spacer. Remove the other one.



4) Remove 2 screws to open Instruction panel bracket. (Slide out to exchange instruction sheet.)



5) Exchange game cartridge. (Just snap in to mount it.) Then close instruction panel bracket.

MARQUEE EXCHANGE

Bracket

Marquee Glass

Marquee

Marquee box



6) Change the Marquee lexan.

7) Close key pad down, Latches on, close coin door . END



RANGER MISSION, WIRING DIAGRAM FOR GUN CONTROL PANEL

