

SATAN'S HOLLOW

General Instructions

Bally

MIDWAY MFG. CO.



GENERAL INSTRUCTIONS

FOR

SATANS HOLLOW

INSTALLATION

1. Unlock and open the coin box door.
2. Remove four (4) "CABINET LEVELING LEGS" from inside the coin box.
3. Tip the cabinet to the side and remove the shipping cleats from its bottom.
 - ° Locate the threaded holes - one in each corner - and install the "CABINET LEVELING LEGS" in them.
 - ° Level the cabinet.
 - ° When finished, the cabinet should be stable in the upright position.
4. Plug the game into a **standard** A.C. wall outlet **ONLY!**

-----WARNING-----

Game **MUST** be
properly grounded.

5. The power ON/OFF switch is located:
 - ° UPRIGHT MODEL: On top of the cabinet toward the back.
 - ° MINI MODEL: In the center of the cabinet back just below the rear access door.
 - ° COCKTAIL TABLE MODEL: Underneath the cabinet on Player No. 2's side.

LINE VOLTAGE SAFETY INTERLOCK SWITCHES

Line voltage SAFETY INTERLOCK SWITCHES have been provided for your protection. The locations of these SAFETY INTERLOCK SWITCHES are:

1. UPRIGHT MODEL: Inside the rear of the cabinet on the right side of the rear access door.

2. MINI MODEL: Inside the rear of the cabinet on the right side of the rear access door.
3. COCKTAIL TABEL: Inside the cabinet on the hinge side of the coin door.

When the cabinet access door(s) are secured in place, the SAFETY INTERLOCK SWITCH plunger(s) are in a fully depressed condition. The game circuit can function normally.

When any cabinet access door(s) are opened, the SAFETY INTERLOCK SWITCH plunger(s) are in a partially extended condition. This isolates the game circuit from the line voltage.

To restore power to the game circuit with the access door(s) open, gently pull the SAFETY INTERLOCK SWITCH plunger(s) out to the fully extended condition. THIS IS TO BE USED FOR SERVICING THE GAME ONLY!

SELF-TEST

A slide switch is provided to make the game run a "Self-Test" on itself. The SELF-TEST SWITCH is located just inside the cabinet on the right side of the coin door frame as you face it.

To put the game into the Self-Test mode; turn the game ON and let it warm up for a few minutes. Then slide the SELF-TEST SWITCH to the ON position and actuate the "TILT" switch on the back side of the coin door just below the door lock to obtain the Self-Test-Menu display on the monitor screen.

When in the Self-Test mode, the monitor screen will display the results of certain test functions the game has run on itself. (These will be discussed in more detail later.)

TO SERVICE THE CONTROL PANEL(S)

1. UPRIGHT MODEL:

- ° The control panel is held in place by two latches, one on the left side and one on the right side of the cabinet.

They are spring loaded to provide constant positive pressure on their latch plates.

They can be reached through the coin door AFTER turning power to the game off.

To release the latches, lift up and toward the center of the control panel.

Once they are released, unhook them from their latch plates.

- ° To remove the control panel:

Raise it up and tilt it toward you until you can see the cable behind it.

Cradling the control panel between yourself and the cabinet, disconnect it from its cabling.

The control panel is now free and can be removed.

- ° To reinstall the control panel, reverse this procedure.

2. MINI MODEL:

- ° The control panel is held in place by two latches, one on the left side and one on the right side of the cabinet.

They are spring loaded to provide constant positive pressure on their latch plates.

They can be reached through the coin door **AFTER turning power to the game off.**

To release the latches, lift up and toward the center of the control panel.

Once they are released, unhook them from their latch plates.

- ° To remove the control panel:

Raise it up and tilt it toward you until you can see the cable behind it.

Cradling the control panel between yourself and the cabinet, disconnect it from its cabling.

The control panel is now free and can be removed.

- ° To reinstall the control panel, reverse this procedure.

3. COCKTAIL TABLE MODEL:

- ° Each control panel is held in place by several screws, two on the inside of the cabinet and three along the bottom edge of the control panel.

Turn the power off to the game.

Open the coin box door and release the two latches on the inside of the cabinet up next to the table top.

CAUTION: The right hand latch is very close to the **HIGH VOLTAGE** on the monitor. **BE CAREFUL!!**

Once they're released, unhook them from their latch plates.

Grasp the table top in the center above the coin door lifting up and to the side to tilt it open.

CAUTION: Due to the weight of the monitor, **EXTREME CARE MUST** be taken when opening the cabinet.

Remove the screws which secure the control panel in place.

- ° To remove the control panel(s):

Disconnect it from its cabling.

The control panel is now free and can be removed.

- ° To reinstall the control panel(s), reverse this procedure.

REMOVAL OF THE MAIN-DISPLAY-GLASS AND/OR THE T.V. BEZEL ASSEMBLY

1. UPRIGHT MODEL:

NOTE: In order to do this, the control panel MUST be removed first. See the "UPRIGHT MODEL" procedure.

- ° **Turn the power to the game off** and remove the control panel. This frees the main-display-glass so it can be lifted up.
- ° By putting your finger in the hole in the middle of the main-display-glass support, you can lift it up and out.
- ° Remove the screws which secure the T.V. bezel assembly in place (front and back).
- ° The T.V. bezel assembly is now free and can be slid out of the cabinet.
- ° To reinstall the T.V. bezel assembly and the main-display-glass, reverse this procedure.

2. MINI MODEL:

NOTE: In order to do this, the control panel MUST be removed first. See the "MINI MODEL" procedure.

- ° **Turn the power to the game off** and remove the control panel.
- ° Remove the screws which secure the glass clamping plate.
- ° Lift out the glass clamping plate. This frees the main-display-glass so it can be lifted up.
- ° By putting your finger in the hole in the middle of the main-display-glass support, you can lift it up and out.
- ° Remove the screws which secure the T.V. bezel assembly and lift it out.

NOTE: Use the hole in the center of the main-display-glass support to grasp it.

- ° Reverse this procedure to reinstall the T.V. bezel assembly and the main-display-glass.

3. COCKTAIL TABLE MODEL:

NOTE: This may be done with the table top in the open or the closed position. If you decide to open the table top, **TURN THE POWER TO THE GAME OFF FIRST.**

- ° Remove the screws which secure the table top glass clamps in place.
- ° Remove the table top glass.
- ° Loosen the screws which secure the T.V. bezel-glass-clamps in place.

Move the clamps to the side and the bezel glass may be removed.

Remove the screws which secure the bezel assembly to the table top and the bezel with four bezel-glass-clamps may be removed.

- ° To reinstall the T.V. bezel assembly and the table top glass, reverse this procedure.

VOLUME CONTROL POT

The volume control pot is located just inside the cabinet on the RIGHT side of the coin door frame. For adjustment, it may be reached through the coin door on ALL models.

To make the sounds louder, turn the pot clockwise (↷) as you face it.

To make the sounds less loud, turn the pot counterclockwise (↶) as you face it.

VOLTAGE CONTROL POTS

The voltage control pots are located on the Linear Power Supply P. C. Board. They are pre-set at the factory and **SHOULD NOT** be tampered with at all **unless** the distributors service department is contacted first.

SELF-TEST

The Self-Test mode is a special mode for checking game play statistics as well as game switches and computer functions. It is the easiest and best way to check for proper operation of the entire game.

NOTE: Putting the game into Self-Test **WILL NOT** cause the game to erase any CREDITS it has in its memory when the Self-Test mode is entered.

You may begin a Self-Test at any time by sliding the Self-Test switch to the "ON" position after the power to the game is on (Self-Test switch located just inside cabinet on right side of coin door frame). When this is done, the game will react as follows:

1. If the game is in the Attract mode when the Self-Test switch is moved to the "ON"

position, it will finish the sequence and then go into the Self-Test mode. This is illustrated by the display of the Self-Test Mode Menue on the monitor screen.

2. If the game is in the Ready-To-Play mode or the Play mode when the Self-Test switch is slid to the "ON" position, it **WILL NOT** go into the Self-Test mode until **AFTER** the players last Missile Launcher has been lost (the game **MUST** be over). At this point, the game will go into the Self-Test mode. Again, this is illustrated by the display of the Self-Test Mode Menue on the monitor screen.
3. The fastest way to enter the Self-Test mode is to slide the Self-Test switch to the "ON" position and then activate the "TILT" switch located on the back side of the coin door just below the lock mechanism. The game will then **IMMEDIATELY** go into the Self-Test mode.

The Self-Test mode has eight (8) major catagories as illustrated by the following Figure of the Self-Test Mode Menue as it should appear on the monitor screen.

1. It is easy to select what catagory you want to enter. By moving the Control Stick left or right, the Cursor at the left of the screen can be moved UP and DOWN, (left=UP) and (right=DOWN), until it is in front of the catagory you want to test. Release the Control Stick at this time.
2. After the Cursor has been positioned, depress either "SHIELD" button on the console and the monitor screen will display the test catagory you have selected.

NOTE: There is one exception to this. If you position the Cursor in fornt of the "PRE-SET" catagory on the Self-Test Mode Menue, when you press the "SHIELD" button on the console - - EVERYTHING, I repeat - EVERYTHING; including ALL information in the "BOOKKEEPING" mode, and ALL operator selected options, will be set back to zero "0" and to the factory recommended settings - respectively.

° Once you are **IN** one of the Self-Test mode catagories, **FOLLOW THE ON-SCREEN INSTRUCTIONS TO COMPLETE THE TEST.**

3. The next group of Figures show the **CORRECT** screen presentation for **EACH** catagory of the Self-Test mode.

The first display of the Self-Test mode is the Self-Test-Mode-Menue. It should look like this:

SELECT DESIRED TEST

- | | |
|---|------------------|
| 1 | SELF DIAGNOSTICS |
| 2 | SOUNDS |
| 3 | PLAYER INPUT |
| 4 | BOOKKEEPING |
| 5 | MACHINE SETUP |
| 6 | CHANNEL TEST |
| 7 | PRESET |
| 8 | GRID DISPLAY |

(MENUE - CONTINUED)

POSITION CURSOR BY MOVING
CONTROL HANDLE

HIT SHIELD BUTTON FOR TEST

During the SELF DIAGNOSTICS section of the Self-Test mode, you will first see a cross hatch pattern on the screen for about 1/2 second. Second, you will see a lot of different colored bars shown on the monitor screen. These bars will be UNpainted one at a time from the top down. Third, you will see the screen painted Red, Blue, and Green in bars from the top down. Fourth, all the different colored bars you saw "Second" are displayed again. And fifth, the different colored bars are replaced by this message: "HIT SHIELD BUTTON TO EXIT".

If the SELF DIAGNOSTICS find one or more bad ROM or RAM chips: instead of going through what is described above, the game will give you a written message as to which parts are bad.

During the SOUNDS section of the Self-Test mode, the game will give a display which looks like the following:

SELECT A SOUND

- 1 ALL SOUNDS
- 2 EXIT
- 3 FLAME SOUND
- 4 SHIELD SOUND
- 5 BASE EXPLOSION
- 6 MISSILE RELEASE
- 7 BOMB
- 8 DIVER RELEASE
- 9 STEAL BASE
- 10 FIRE BALL
- 11 MUSIC 1
- 12 MUSIC 2
- 13 MIKE HIT
- 14 TARGET HIT
- 15 COIN
- 16 EXTRA BASE
- 17 BRIDGE BEGIN
- 18 BRIDGE COMPLETE
- 19 TILT
- 20 10000 BONUS FLAG
- 21 BRIDGE PICK UP
- 22 1000 BONUS FLAG
- 23 FLY BONUS FLAG

POSITION CURSOR BY MOVING
CONTROL HANDLE

HIT SHIELD BUTTON FOR TEST

During the PLAYER INPUT section of the Self-Test mode, the game will give a display which looks like the following:

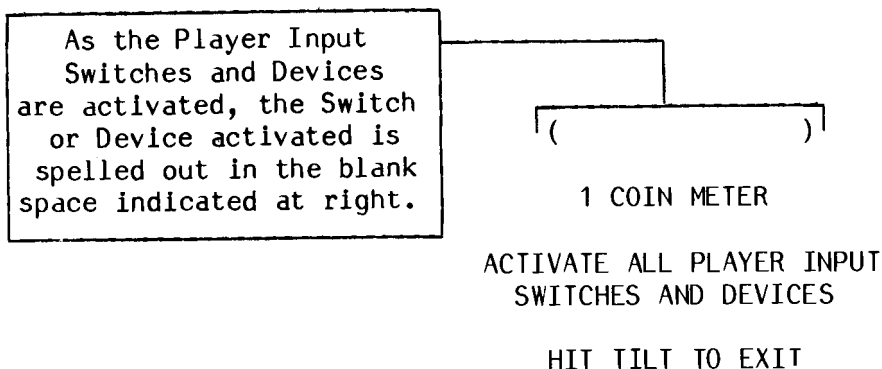

During the BOOKKEEPING section of the Self-Test mode, the game will give a display which looks like the following:

SELECT A REPORT OR EXIT

CHUTE 1 COINS _____

CHUTE 2 COINS _____

LONGEST GAME _____

SHORTEST GAME _____

HIGHEST SCORE _____

LOWEST SCORE _____

TIME REPORT

SCORE REPORT

EXIT

POSITION CURSOR BY MOVING CONTROL HANDLE

HIT SHIELD BUTTON FOR TEST

In the TIME REPORT and SCORE REPORT sections of the BOOKKEEPING mode, the game will give displays which look like the following:

TIME REPORT				SCORE REPORT			
0	TO	30 SEC	_____	0	TO	5000 PTS	_____
30	TO	60 SEC	_____	5000	TO	10,000 PTS	_____
60	TO	90 SEC	_____	10,000	TO	20,000 PTS	_____

(TIME REPORT AND SCORE REPORT - CONTINUED)

90	TO	120 SEC	_____	20,000	TO	40,000 PTS	_____
120	TO	150 SEC	_____	40,000	TO	70,000 PTS	_____
150	TO	180 SEC	_____	70,000	TO	100,000 PTS	_____
3	TO	4 MIN	_____	100,000	TO	150,000 PTS	_____
4	TO	5 MIN	_____	150,000	TO	200,000 PTS	_____
5	TO	6 MIN	_____	200,000	TO	250,000 PTS	_____
OVER		6 MIN	_____			OVER 250,000 PTS	_____

HIT SHIELD BUTTON TO EXIT

HIT SHIELD BUTTON TO EXIT

During the SETUP OPTIONS section of the Self-Test mode, the game will give a display which looks like the following:

SETUP OPTIONS

COIN CHUTE 1

*1 COINS FOR
*1 CREDITS

COIN CHUTE 2

*1 COINS FOR
*1 CREDITS

*1 CREDITS FOR
*3 BASES

*2 CREDITS FOR
*7 BASES

EXTRA BASE AT
*30,000 PTS

*3 DIFFICULTY LEVEL

EXIT

USE SHIELD BUTTON TO
POSITION CURSOR
USE 1 AND 2 PLAYER
BUTTONS TO ALTER
OPTIONS

* = Factory recommended settings.

The Difficulty Level setting has a range of 1 to 9. With 1 being the easiest level of play and 9 being the most difficult level of play. We recommend that a setting of 3 be used as a beginning point.

Game play can then be made **MORE** difficult or **LESS** difficult, according to the skill levels attained by the players in your area.

During the CHANNEL TEST section of the Self-Test mode, the game will give a display which looks like the following:

CHANNEL TEST

CHANNEL 1
CHANNEL 2
CHANNEL 3
CHANNEL 4
CHANNEL 5
CHANNEL 6

HIT KICK BUTTON TO EXIT

Once you enter the CHANNEL TEST section of the Self-Test mode, the game automatically tests Channels 1 through 6 giving a tone for each one as it checks it. After the 6th Channel is tested, the game automatically repeats the test until the Shield button is hit. It then goes back to the Self-Test Mode Menu.

During the GRID DISPLAY section of the Self-Test mode, the game shows a white cross hatch pattern on the monitor screen. This is for alignment and/or test purposes. This pattern will remain on the monitor screen until the Shield button is hit. The game will then go back to the Self-Test Mode Menu.

To leave the Self-Test mode, simply slide the Self-Test switch to the "OFF" position at ANY time. The game will then run through the ROM/RAM test display after which normal game functions will then return to the monitor screen.

<u>SATANS HOLLOW</u>											
<u>OPTION SWITCH SETTINGS</u>											
//////////////////SWITCH NO. 1 - AT B 3 - LOCATED ON SOUND I/O P.C. BOARD//////////////////											
2 COIN METERS *** 1 COIN METER	<u>SW#1</u> ON OFF	<u>SW#2</u>	<u>SW#3</u> NOT USED	<u>SW#4</u> NOT USED	<u>SW#5</u> NOT USED	<u>SW#6</u> NOT USED	<u>SW#7</u> NOT USED	<u>SW#8</u> NOT USED	<u>SW#9</u> NOT USED	<u>SW#10</u>	
----- MINI / UPRIGHT COCKTAIL TABLE	ON OFF										
----- FREEZE VIDEO *** NORMAL OPERATION										ON OFF	
//////////////////SWITCH NO. 3 - AT D 14 - LOCATED ON SOUND I/O P.C. BOARD//////////////////											
*** NORMAL OPERATION SOUND I/O DIAGNOSTIC MODE	<u>SW#1</u> OFF ON	** <u>SW#2</u>	** <u>SW#3</u>	** <u>SW#4</u>							
----- *** NORMAL OPERATION RAM/ROM TEST INDICATES TEST RESULTS VIA YELLOW L E D ON SOUND I/O BOARD: <u>FAST FLASH = BAD ROM</u> <u>SLOW FLASH = BAD RAM</u>					OFF ON						
----- *** NORMAL OPERATION OSCILLATOR TEST					OFF ON						
----- *** NORMAL OPERATION FILTER TEST					OFF ON						
* THIS SWITCH NOT USED ON UPRIGHT MODELS. ** NO EFFECT IF SW#1 OF SWITCH NO. 3 IS IN THE "OFF" POSITION. *** INDICATES FACTORY RECOMMENDED SETTINGS.								PART NO. M051-00941-A011			

THE REMAINDER OF SATANS HOLLOW'S MOST COMMON OPTION SETTINGS ARE CONDUCTED DURING THE MACHINE SETUP PORTION OF THE SELF-TEST MODE. SIMPLY FOLLOW THE ON-SCREEN INSTRUCTIONS TO MAKE ANY ADJUSTMENTS YOU FEEL ARE NECESSARY.

<u>M C R II S Y S T E M</u>									
<u>P. C. BOARD JUMPER OPTIONS</u>									
////////////////////////////////////V I D E O G E N E R A T O R P. C. B O A R D////////////////////////////////////									
MANUFACTURER	EPROM NO.	JW#1	JW#2	JW#3	JW#4	JW#5	JW#6	JW#7	JW#8
MOTOROLA	68764	#	*	*	#	*	*	*	*
	----- 68766	#	*	*	#	*	*	*	*
INTEL	2764	*	#	#	*	#	*	*	#
T. I.	2564	#	*	*	#	*	#	#	*
////////////////////////////////////C. P. U. P. C. B O A R D////////////////////////////////////									
MANUFACTURER	EPROM NO.	JW#1	JW#2	JW#3	JW#4	JW#5	JW#6	NOTE:	
NUMEROUS MFR'S	2532	*	#	*	*	#	*	JUMPER OP- TION FOR PROGRAM ROMs ONLY.	
NUMEROUS MFR'S	2732	*	#	*	*	*	#		
////////////////////////////////////S O U N D I / O P. C. B O A R D////////////////////////////////////									
MANUFACTURER	EPROM NO.	JW#1	JW#2						
NUMEROUS MFR'S	2532	*	#						
NUMEROUS MFR'S	2732	#	*						

* = CUT JUMPER WIRES WHERE THIS SYMBOL "*" APPEARS.

= LEAVE JUMPER WIRES IN WHERE THIS SYMBOL "#" APPEARS.

The above table illustrates the fact that the Video Generator P.C. Board used in the MCR II System has 8 jumper wires, the C.P.U. P.C. Board used in the MCR II System has 6 jumper wires, and the Sound I/O P.C. Board used in the MCR II System has 2 jumper wires.

All of the above Boards can be used with a variety of different **SETS of EPROM chips**. However, these EPROMS are not all made by the same manufacturer and do have some internal differences. So, in order to make them function properly in their respective P.C. Boards, certain jumper wires on these Boards have to be cut.

The above table tells you which jumpers to cut (depending on which EPROM set you're going to use) by showing a "*" under that jumper wires number. If there is **NO "*" under a jumper wires number, THAT PARTICULAR JUMPER WIRE IS NOT TO BE CUT.**

V Technical Troubleshooting

Troubleshooting

Introduction

The most common problems occur in harness components such as the coin acceptor, player controls, interconnecting wiring, etc. The TV monitor and PCB computer cause their share of problems too, but not as much as the harness and its component parts. TV monitor troubleshooting will not be covered here because it is covered in that section of this manual.

As you already know, the PCB computer is a complex device with a number of different circuits. Some circuits remain basically the same among games, but overall there are a great many differences between them. PCB troubleshooting procedures, therefore, can be lengthy and will differ greatly among games. However, some basic Z-80 CPU information is involved in this section.

General Suggestions

The first step in any troubleshooting procedure is correctly identifying the malfunction's symptoms. This includes not only the circuits or features malfunctioning, but also those still operational. A carefully trained eye will pick up other clues as well. For instance, a game in which the computer functions fail completely just after money was collected may have a quarter shorting the PCB traces. Often, an experienced troubleshooter will be able to spot the cause of the problem even before opening the cabinet.

After all the clues are carefully considered, the possible malfunctioning areas can be narrowed down to one or two good suspects. Those areas can be examined by a process of elimination until the cause of the malfunction is discovered.

Harness Component Troubleshooting

Typical problems falling in this category are coin and credit problems, power problems and failure of individual features.

NO GAME CREDIT

For example, your prospective player inserts his quarter and is not awarded a game. The first item to check is if the quarter is returned. If the quarter is returned, the malfunction most certainly lies in the coin acceptor itself. First, use a set of test coins (both old and new) to ascertain that the player's coin is not undersize or underweight. If your test coins are also returned, coin acceptor servicing is indicated. Generally, the cause of this particular problem is a maladjusted magnet gate. Normally, this will mean slightly closing the magnet gate a little by turning the adjusting screw out a bit (see section on coin acceptor for more details).

If the quarter is not returned and there is no game credit, the cause of the malfunction may be in one of several areas. First try operating the coin return button; if the coin is returned, the problem is most likely in the magnet gate. Enlarge the gap according to the coin acceptor service procedures. If this does not cure the problem, remove the coin acceptor, clean it and perform the major adjustment procedure.

If the trapped coin is not returned when the wiper lever is actuated, you may have an acceptor jammed by a slug, gummed up with beer, a jammed coin chute, or mechanical failure of the acceptor mechanism. In this case, first check for the slug that will generally be trapped against the magnet. If so, simply remove the slug and test the acceptor. If the chute is blocked, remove the acceptor and remove the jammed coins. If there is actual failure of the acceptor, remove the unit and repair as indicated in the coin acceptor service procedures.

If the coin is making its way through the acceptor (that is, falling into the coin box), yet there is still no game credit, you either have a mechanical failure of the coin switch or electrical failure of the coin and credit circuits. The first place to begin is by checking the coin switch. Most of these switches are the make/break variety of micro switch, which is checked by testing for continuity between the NO, NC, and C terminals. When not actuated, the NC and C terminals should be continuous and the NO terminal open. When operated, the NO and C terminals should close and the NC should be open. If the coin switch checks out, examine the connections to the terminals to make sure there is good contact. If necessary, use the continuity tester and check from the terminal lug on the switch to the associated PCB trace. This will tell you if there is a continuous line all the way to the credit circuit.

If the coin switch wires do not check out, the problem is in the computer — most likely in the coin and credit circuitry.

If you do get game credit when a coin is deposited, but the game will not start when the start switch is pressed, you may have a problem in the start switch, the interconnecting wiring or in the computer. First check the switch. If the switch is OK, proceed to check the wiring. Again, make sure you go from the terminal lug on the switch to the PCB trace. This way, you will check the terminal contact as well as PCB edge connector contact. If the wiring is continuous, proceed to check the PCB credit circuit. If not, check each section of the wiring, until the discontinuity is located. If the wiring is OK, the problem must lie in the computer.

Transformer and Line Voltage Problems

Your machine must have the correct line voltage to operate properly. If the line voltage drops too low, a circuit in the computer will disable game credit. The point at which the computer will fail to work will vary some from game to game, but no game will work on line voltage that drops below 105 VAC.

Low line voltage may have many causes. Line voltage normally fluctuates a certain amount during the day as the total usage varies. Peak usage times occur mainly at dawn or dusk, so if your machine's malfunction seems to be related to the time of day, this may be a factor. A large load connected to the same line as the game (such as a large air conditioner or other device with an exceptionally large motor) may drop the line voltage significantly when starting up. This drop can result in an intermittent credit problem. In addition, poor connections in the location wiring, plug, or line cord may also cause a significant drop in power. Cold solder joints in the game's harness, especially in areas like the transformer connections, interlock switch, or fuse block, may also produce the same results, although probably on a more permanent basis.

Sometimes location owners (especially in bars) replace light switches with dimmer rheostats, and the game is sometimes on the same line. Obviously, the voltage available to the game is going to drop dramatically when the dimmer is turned.

In any case, the way to check for correct line voltage is with your VOM. Set the VOM to 250 VAC and stick the probes in the wall receptacle. If it's OK here, check the transformer primary connections. If you do not get 117 VAC, examine the solder joints on the transformer, fuse block, and interlock switch. If you do get 117 VAC, the problem must be either in the transformer, harness connections, or in the PCB power supply.

If you suspect the transformer, check its secondaries with the VOM set to 50 VAC and correlate the readings with the legend on the side of the transformer. The transformer must also be correctly grounded, so check the ground potential as well, especially if there is a hum bar rolling up or down the TV screen

HARNESS PROBLEMS

Other harness problems include blowing fuses and malfunctioning controls. The repeating blown-fuse problem can sometimes be quite exasperating to solve, for short circuits have the tendency to occur in areas almost impossible to find. First, try inserting a new fuse, as old fuses age and blow without cause. If the new one also blows, you definitely have a short.

The best way to approach this problem is by turning the power off and disconnecting devices that may be causing the problem, such as the TV, transformer, and PCB. Disconnect the devices by pulling off their connectors, but do not allow them to touch. If necessary, insulate them with small pieces of electrical tape. Then, connect your VOM across the terminals of the fuse block (all electrical power shut off), and set it to one of the resistance scales. This will save blowing a fuse each time you want to check the circuit.

If the VOM reveals that disconnecting the devices removed the short, reconnect the devices one by one until the short returns. The last device connected is the one that is at fault. If the VOM reads a short even after the devices are disconnected, the fault must lie in the harness itself, and only patient exploration will reveal its location. First, carefully examine all the wiring, looking for terminals that may be touching, metal objects such as coins shorting connections or burned insulation. If necessary, use the VOM to check each suspected wire.

MALFUNCTIONING CONTROLS

One of the most common problems here is a bad potentiometer. Typically, a bad pot will cause the image to jump as it reaches a certain point. The only cure for this one is to install a new pot.

If a feature that is operated by a switch (for example, joysticks, foot pedals, control panel buttons) does not operate at all, check the switch with a VOM or continuity tester to verify its operation. If the switch does not check out, replace it. If the switch is OK, you should suspect the input to the switch from the PCB. In this case, get out the harness and logic schematics and check to see what kind of input it is. In many cases, the input will be +5 VDC. If so, use the VOM to check its presence. Normally, the switch is used to pull a +5 VDC line LOW to GND or to pull a LOW line HIGH. If the PCB output is missing, check the wire length from the PCB. If you find the signal at the PCB trace, the wire length or connection is at fault. If not, begin exploring the PCB using the logic schematics

A Glossary of Microprocessor Terms

MICROPROCESSOR — one or several microcircuits that perform the function of a computer's CPU. Sections of the circuit have arithmetic and comparative functions that perform computations and executive instructions

CPU — central-processing unit. A computing system's "brain", whose arithmetic, control and logic elements direct functions and perform computations. The microprocessor section of a microcomputer is on one chip or several chips.

PROM — programmable read-only memory. User permanently sets binary on-off bits in each cell by selectively fusing or not fusing electrical links. Non-erasable. Used for low-volume applications

EPROM — erasable, programmable, read-only memory. Can be erased by ultraviolet light bath, then reprogrammed. Frequently used during design and

development to get programs debugged, then replaced by ROM for mass production.

ROM — read-only memory. The program, or binary on-off bit pattern, is set into ROM during manufacture, usually as part of the last metal layer put onto the chip. Nonerasable. Typical ROM's contain up to 16,000 bits of data to serve as the microprocessor's basic instructions.

RAM — random-access memory. Stores binary bits as electrical charges in transistor memory cells. Can be read or modified through the CPU. Stores input instructions and results. Erased when power is turned off.

LSI — large scale integration. Formation of hundreds or thousands of so-called gate circuits on semiconductor chips. Very large scale integration (VLS) involves microcircuits with the greatest component density.

MOS — metal-oxide semiconductor. A layered construction technique for integrated circuits that achieves high component densities. Variations in MOS chip structures create circuits with speed and low-power requirements, or other advantages (static will damage a MOS chip).

Introduction to the Z-80 CPU

The term "microcomputer" has been used to describe virtually every type of small computing device designed within the last few years. This term has been applied to everything from simple "microprogrammed" controllers constructed out of TTL MSI up to low end minicomputers with a portion of the CPU constructed out of TTL LSI "bit slices." However, the major impact of the LSI technology within the last few years has been with MOS LSI. With this technology, it is possible to fabricate complete and very powerful computer systems with only a few MOS LSI components.

The Zilog Z-80 family of components can be configured with any type of standard semiconductor memory to generate computer systems with an extremely wide range of capabilities. For example, as few as two LSI circuits and three standard TTL MSI packages can be combined to form a simple controller. With additional memory and I/O devices a computer can be constructed with capabilities that only a minicomputer could previously deliver.

New products using the MOS LSI microcomputer are being developed at an extraordinary rate. The Zilog Z-80 component set has been designed to fit into this market through the following factors:

1. The Z-80 is fully software compatible with the popular 8080A CPU.
2. Existing designs can be easily converted to include the Z-80.
3. The Z-80 component set is at present superior in both software and hardware capabilities to any other microcomputer system on the market today.
4. For increased throughput the Z80A operating at a 4 MHz clock rate offers the user significant speed advantages.

Microcomputer systems are extremely simple to construct using Z-80 components. Any such system consists of three parts:

1. **CPU (Central Processing Unit)**
2. **Memory**
3. **Interface Circuits to peripheral devices**

The CPU is the heart of the system. Its function is to obtain instructions from the memory and perform the desired operations. The memory is used to contain instructions and in most cases data that is to be processed. For example, a typical instruction sequence may be to read data from a specific peripheral device, store it in a location in memory, check the parity and write it out to another peripheral device. Note that the Zilog component set includes the CPU and various general purpose I/O device controllers, while a wide range of memory devices may be used from any source. Thus, all required components can be connected together in a very simple manner with virtually no other external logic.

General Purpose Registers

There are two matched sets of general purpose registers, each set containing six 8-bit registers that may be used individually as 8-bit registers or as 16-bit register pairs by the programmer. One set is called BC, DE and HL while the complementary set is called BC', DE' and HL'. At any one time the programmer can select either set of registers to work with through a single exchange command for the entire set. In systems where fast interrupt response is required, one set of general purpose registers and an accumulator/flag register may be reserved for handling this very fast routine. Only a simple exchange command need be executed to go between the routines. This greatly reduces interrupt service time by eliminating the requirement for saving and retrieving register contents in the external stack during interrupt or subroutine processing. These general purpose registers are used for a wide range of applications by the programmer. They also simplify programming, especially in ROM based systems where little external read/write memory is available.

Arithmetic & Logic Unit (ALU)

The 8-bit arithmetic and logical instructions of the CPU are executed in the ALU. Internally the ALU communicates with the registers and the external

data bus on the internal data bus. The type of functions performed by the ALU include:

Add	Left or right shifts or rotates (arithmetic and logical)
Subtract	Increment
Logical AND	Decrement
Logical OR	Set bit
Logical Exclusive OR	Reset bit
Compare	Test bit

Instruction Register and CPU Control

As each instruction is fetched from memory, it is placed in the instruction register and decoded. The control sections performs this function and then generates and supplies all of the control signals necessary to read or write data from or to the registers, control the ALU and provide all required external control signals.

Z-80 CPU Pin Description

The Z-80 CPU is packaged in an industry standard 40 pin Dual In-Line Package. The I/O pins are shown in the below figure and the function of each is described.

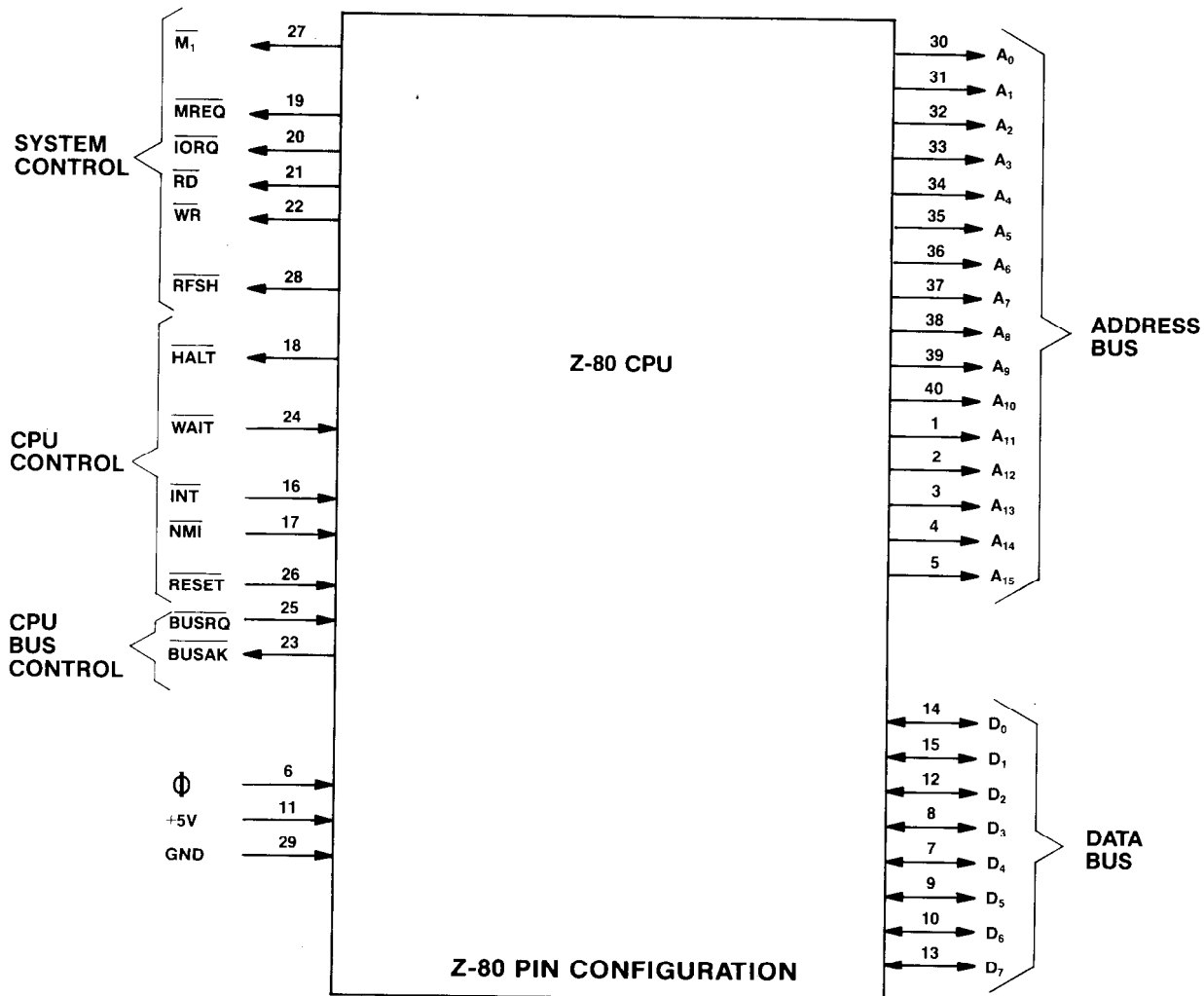

A₀-A₁₅**(Address Bus)**

Tri-state output, active high. A₀-A₁₅ constitute a 16-bit address bus. The address bus provides the address for memory (up to 64K bytes) data exchanges and for I/O device data exchanges. I/O addressing uses the 8 lower address bits to allow the user to directly select up to 256 input or 256 output ports. A₀ is the least significant address bit. During refresh time, the lower 7 bits contain a valid refresh address.

D₀-D₇**(Data Bus)**

Tri-state input/output, active high. D₀-D₇ constitute an 8-bit bidirectional data bus. The data bus is used for data exchanges with memory and I/O devices.

M₁**(Machine Cycle one)**

Output, active low. $\overline{M_1}$ indicates that the current machine cycle is the OP code fetch cycle of an instruction execution. Note that during execution of 2-byte op-codes, $\overline{M_1}$ is generated as each op code byte is fetched. These two byte op-codes always begin with CBH, DDH, EDH or FDH. $\overline{M_1}$ also occurs with \overline{IORQ} to indicate an interrupt acknowledge cycle.

MREQ**(Memory Request)**

Tri-state output, active low. The memory request signal indicates that the address bus holds a valid address for a memory read or memory write operation.

IORQ**(Input/Output Request)**

Tri-state output, active low. The \overline{IORQ} signal indicates that the lower half of the address bus holds a valid I/O address for a I/O read or write operation. An \overline{IORQ} signal is also generated with an M₁ signal when an interrupt is being acknowledged to indicate that an interrupt response vector can be placed on the data bus. Interrupt Acknowledge operations occur during M₁ time while I/O operations never occur during M₁ time.

RD**(Memory Read)**

Tri-state output, active low. \overline{RD} indicates that the CPU wants to read data from memory or an I/O device. The addressed I/O device or memory should use this signal to gate data onto the CPU data bus.

WR**(Memory Write)**

Tri-state output, active low. \overline{WR} indicates that the CPU data bus holds valid data to be stored in the addressed memory or I/O device.

RFSH**(Refresh)**

Output, active low. \overline{RFSH} indicates that the lower 7 bits of the address bus contain a refresh address for dynamic memories and the current MREQ signal should be used to do a refresh read to all dynamic memories.

HALT**(Halt state)**

Output, active low. \overline{HALT} indicates that the CPU has executed a HALT software instruction and is awaiting either a non maskable or a maskable interrupt (with the mask enabled) before operation can resume. While halted, the CPU executes NOP's to maintain memory refresh activity.

WAIT**(Wait)**

Input, active low. \overline{WAIT} indicates to the Z-80 CPU that the addressed memory or I/O devices are not ready for a data transfer. The CPU continues to enter wait states for as long as this signal is active. This signal allows memory or I/O devices of any speed to be synchronized to the CPU.

INT**(Interrupt Request)**

Input, active low. The Interrupt Request signal is generated by I/O devices. A request will be honored at the end of the current instruction if the internal software controlled interrupt enable flip-flop (IFF) is enabled and if the \overline{BUSRQ} signal is not active. When the CPU accepts the interrupt, an acknowledge signal (\overline{IORQ} during M₁ time) is sent out at the beginning of the next instruction cycle. The CPU can respond to an interrupt in three different modes that are described in detail in section 5.4 (CPU Control Instructions).

NMI**(Non-Maskable Interrupt)**

Input, negative edge triggered. The non maskable interrupt request line has a higher priority than \overline{INT} and is always recognized at the end of the current instruction, independent of the status of the interrupt enable flip-flop. NMI automatically forces the Z-80 CPU to restart to location 0066_H. The program counter is automatically saved in the external stack so that the user can return to the program that was interrupted. Note that continuous \overline{WAIT} cycles can prevent the current instruction from ending, and that a \overline{BUSRQ} will override a NMI.

RESET

Input, active low. RESET forces the program counter to zero and initializes the CPU. The CPU initialization includes:

- 1) Disable the interrupt enable flip-flop

- 2) Set Register I = 00H
- 3) Set Register R = 00H
- 4) Set Interrupt Mode 0

During reset time, the address bus and data bus go to a high impedance state and all control output signals go to the inactive state.

BUSRQ

(Bus Request)

Input, active low. The bus request signal is used to request the CPU address bus, data bus and tri-state output control signals to go to a high impedance state so that other devices can control these buses. When BUSRQ is activated, the CPU will set these

buses to a high impedance state as soon as the current CPU machine cycle is terminated.

BUSAK

(Bus Acknowledge)

Output, active low. Bus acknowledge is used to indicate to the requesting device that the CPU address bus, data bus and tri-state control bus signals have been set to their high impedance state and the external device can now control these signals.

CLK

(Clock)

Single phase TTL level clock which requires only a 330 ohm pull-up resistor to +5 volts to meet all clock requirements.

PLEASE NOTE:

THE INFORMATION CONTAINED IN THIS SECTION IS TOLD IN AN EASY TO UNDERSTAND MANNER AND IS INTENDED TO AID THOSE WITHOUT AN ELECTRONICS DEGREE IN TROUBLESHOOTING AND REPAIRING THEIR GAMES T.V. MONITOR.

IF YOU READ THROUGH THIS SECTION AND STILL HAVE QUESTIONS, PLEASE CONTACT YOUR DISTRIBUTOR OR MIDWAY MANUFACTURING COMPANY AT THE TOLL FREE NUMBER PROVIDED WITH YOUR GAMES PAPERS.

OUR STAFF AND OUR DISTRIBUTORS STAND READY TO HELP YOU!

THANK YOU

VI T.V. Monitor

Color T.V. Monitor

Introduction: (How to use this section of your manual.)

This section has been designed to simply familiarize you with one of the more mystical components in your game — the T.V. monitor. If you are an electronics technician who is quite knowledgeable on the subject, you may decide to just go to the schematics and start troubleshooting the defective monitor. But if you are like most people, a monitor is a T.V. set, and that means a complex doo-dad that means big buck repairs. This isn't necessarily so. This section of the manual will acquaint you with the monitor and could just help you repair it if you feel adventurous enough to give it a try. If you have any knowledge of electronics, especially the use of a voltmeter, the repairs you can make are astonishing. Just keep in mind that **ELECTRICITY CAN BE VERY DANGEROUS, SO BE CAREFUL!!**

If you want to understand how a monitor works, just read the "THEORY OF OPERATION" subsection. If you wish, you can follow along with the schematics. The information is presented in a very basic manner but more complete treatment of the subject can be found in the technical sections of bookstores.

If you want to attempt to repair your monitor, it would be a good idea to read this whole section beginning to end before starting. **Pay attention to all warnings**

and take them seriously. The more equipment you have the better, but a low cost Volt-Ohm-Milliameter can often do the trick. Here are the steps to take:

1. Find the symptom that matches the problems your monitor has in the "SYSTEM — DIAGNOSIS" subsection. The diagnosis tells the circuit or area the problem may be in and possibly even the actual component causing it.
2. Once you have the circuit that is causing the trouble, read the "TROUBLESHOOTING" subsection to learn the procedure for finding the bad part.
3. Next, go to the schematic section and find the schematic that matches your monitor. It may be helpful to read the "DIFFERENCES BETWEEN MONITORS" subsection if you are unsure of which monitor you have. Use the schematic to see what parts are in the offending circuit.

That really is all there is to it. Just remember that there are some bizarre or rare symptoms not covered, or that a monitor may have two or more different problems that only a genius, the experienced, or an experienced genius can figure out. But be patient, follow safety precautions, and remember that there is also literature available from the monitor companies through your distributor or from Midway Manufacturing Company on request. (There is a toll free number on the back side of the front cover of this manual.)

Symptom Diagnosis

- 1. Insufficient width or height:**
 - A. Horizontal line (due to VERTICAL CIRCUIT DEFECT).
 - Bad yoke.
 - Bad vertical output section.
 - Open fusible resistor in vertical section.
 - Bad height control.
 - Bad flyback.
 - B. Vertical line (due to HORIZONTAL CIRCUIT DEFECT).
 - Bad yoke.
 - Open width coil.
 - Open part in horizontal output section.
- 2. Picture spread out too far or crushed in certain areas:**
 - A. Horizontal or vertical output transistor.
 - B. Bad component in output circuitry.
- 3. Line too close with black spacing:**
 - A. Problem in vertical section causing poor linearity.
- 4. Poor focus and convergence:**
 - A. Bad high voltage transformer ("flyback") or control.
 - B. Focus voltage wire not connected to neck-board terminal.
- 5. Colors missing; check:**
 - A. Interface color transistors.
 - B. Color output transistors.
 - C. Cracked printed circuit board.
 - D. Color circuits.
 - E. Video input jack.
- 6. Picture not bright enough:**
 - A. Weak emission from picture tube. (Turn horizontal sync off frequency and put brightness all the way up for about 15 minutes. Occasionally this cures the problem.)
- 7. Silvery effect in white areas; check:**
 - A. Beam current transistors.
 - B. Weak picture tube emission.
- 8. Too much brightness with retrace lines; check:**
 - A. Beam limiter transistors.
 - B. Brightness and/or color blanking control set too high.
- 9. Increasing brightness causes an increase in size and poor focus.**
 - A. Weak high voltage rectifier or regulation (high voltage unit).
- 10. Small picture and/or poor focus:**
 - A. Low B+ voltage (power supply trouble).
- 11. Vertical rolling:**
 - A. Vertical oscillator transistor, IC, or circuit.
 - B. No sync from logic board.
- 12. Horizontal line across center:**
 - A. Vertical output circuit is dead (see symptom No. 1. A.).
 - B. Vertical oscillator is not putting out the right wave form.
- 13. Picture bends:**
 - A. Horizontal sync needs adjusting.
 - B. Magnetic or electromagnetic interference.
- 14. Flashing picture, visible retrace lines:**
 - A. Broken neck board.
 - B. Internal short circuit in the picture tube (arcing).
- 15. Unsymmetrical picture or sides of picture:**
 - A. Defective yoke.
- 16. No brightness, power supply operating — No high voltage for the picture tube; check:**
 - A. Horizontal oscillator.
 - B. Horizontal amplifier and output.
 - C. Flyback transformer (high voltage unit).
- 17. No brightness, high voltage present; check:**
 - A. Heater voltage to the tube at the neck board.
 - B. Screen-grid voltage for the tube.
 - C. Focus voltage.
 - D. Grid to cathode picture tube bias.
- 18. No high voltage; check:**
 - A. For AC input to the "flyback".
 - B. Horizontal deflection stages.
 - C. Flyback transformer.
 - D. Yoke.
 - E. Power supply.
- 19. No horizontal and vertical hold; check:**
 - A. Sync transistors and circuit.
 - B. Wires and jack from logic board to the monitor.
- 20. Wavy picture — (power supply defect); check:**
 - A. Transistors, diodes, electrolytic capacitors in the power supply.

21. Moving bars in picture:

- A. Ground connector off between monitor and logic boards.
- B. Defect in the power supply (see wavy picture symptom).

22. Washed out picture (see picture not bright enough):

- A. Check video signal at the cathode pins with an oscilloscope. If there is about 80 volts peak to peak, the picture tube has weak emission.

23. Monitor won't turn on:

- A. Problem in the power supply: Check fuse, transistors, open fusible resistor.
- B. Shorted horizontal output transistor

- C. Defective high voltage disabling circuit.
- D. Crack(s) somewhere on main chassis board.

24. Can't adjust purity or convergence:

- A. Use a degausser to demagnetize the picture tube carefully following your degausser's instructions.
- B. Picture tube defective.
- C. Metal foreign material is in picture tube shield.
- D. Nearby equipment is electromagnetically interfering.
- E. The poles of the earth are pulling off the purity.
- F. Poor focus or width of picture.

Guide To Schematic Symbols

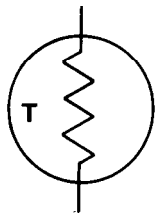

THERMISTOR
(POLARITY DOESN'T MATTER)

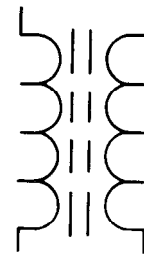

IRON CORE TRANSFORMER
(SUCH AS A FLYBACK)



INDUCTOR, COIL, CHOKE
(POLARITY DOESN'T MATTER)



FUSE
(POLARITY DOESN'T MATTER)

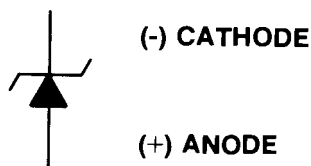

ZENER DIODE

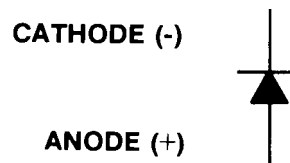

DIODE

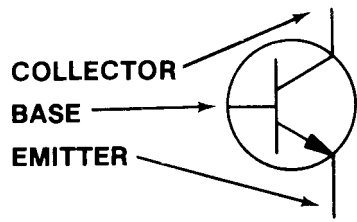

NPN TRANSISTOR

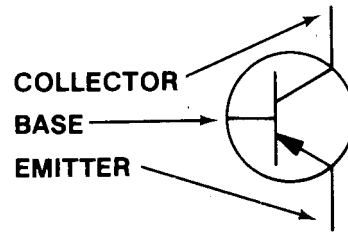

PNP TRANSISTOR



VARIABLE RESISTOR, POT, CONTROL
(POLARITY DOESN'T MATTER)



RESISTOR
(POLARITY DOESN'T MATTER)

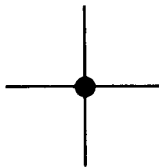

LINES ARE CONNECTED

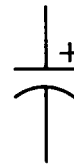

ELECTROLYTIC CAPACITOR

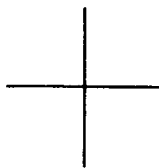

LINES ARE NOT CONNECTED

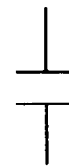

CAPACITOR
(POLARITY DOESN'T MATTER)

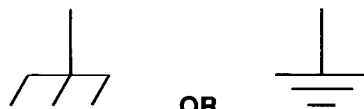

OR
GROUND

Troubleshooting

Troubleshooting monitors requires experience, patience, **and luck**. The first step is to match the symptom the monitor displays to the diagnosis next to it in the "SYMPTOM-DIAGNOSIS" subsection. This will pinpoint the circuit the problem is probably in, and often the parts to check. Next, the circuit should be visually inspected to see if there are any parts broken, burned, or if something is there that shouldn't be, like a loose screw, etc. Some parts go bad before others and should be checked first. In fact, following is the general order in which parts usually go bad:

1. Semiconductors (like transistors, diodes, and integrated circuits).
2. Fusible resistors.
3. Electrolytic capacitors.
4. Resistors.
5. Capacitors and coils.

Always remember that a monitor can bite like a snake. Even when it is turned off, capacitors hold voltage and will discharge it to you should you be touching chassis ground. The picture tube or CRT, itself, is a giant capacitor, so avoid the flyback anode plug hole. With the monitor on, the power supply circuit and/or the flyback, which puts out at least 18,000 volts, **CAN BE KILLERS!!** Avoid handling power transistors (usually output transistors), yoke terminals, and other high power components when the monitor is on.

WARNING: That picture tube is a bomb!

When it breaks, first it implodes, then it explodes. Large pieces of glass have been known to fly in excess of 20 feet in all directions. **DO NOT** carry it by the long, thin neck. Discharge its voltage to ground by shorting the anode hole to ground. Use a plastic handled screwdriver, connect one end of a wire with an alligator clip at each end to chassis ground and the other end to the metal shaft of the screwdriver. Using **ONE HAND ONLY** (put the other in your pocket) and touching **ONLY** the plastic handle of the screwdriver (**DO NOT TOUCH THE METAL SHAFT**) stick the blade of the screwdriver into the anode hole. Be prepared for a fairly loud pop and a flash. The longer the monitor has been turned off, the smaller the pop and dimmer the flash. But **BE CAREFUL**, picture tubes will hold a very

healthy charge for at least **a week** if not longer. Even after you've discharged it once, it may still carry a residual charge. It's better to be too careful than dead, which is why electronic equipment always carries stickers referring servicing to qualified personnel. Handle the side with the viewing screen against your chest when changing it. **ALWAYS** wear safety goggles when handling the picture tube.

To maintain the safety and performance of the monitor, always use exact replacement parts. For instance, the wrong components in the power supply can cause a fire, or the wrong color transistor may give a funny color to the picture. Service your monitor on a nonconductive firm table like wood, **NOT METAL**, and take off all of your jewelry just in case. With all this in mind, you are ready to begin troubleshooting.

Observe the picture carefully. Try to vary the appropriate control that would most likely affect your particular symptom. For example, if there is poor brightness or no picture, try turning up the brightness or contrast control. If the controls have no effect at all, chances are there is trouble with the control itself, the circuit it controls, or a nearby circuit that may be upsetting voltages. Go to the list of symptoms and determine with the schematic where the bad circuit is.

CAUTION:

Keep in mind that capacitors hold a charge as can the picture tube (for at least a week and usually longer), and could shock you.

First, check for obvious visual defects such as broken or frayed wires, solder where it is not supposed to be, missing components, burned components, or cracked printed circuit boards. If everything looks good up to this point, make sure that diodes, electrolytic capacitors, and transistors have their leads connected in the right polarity as shown on the schematic and the circuit board.

Turn on the power and measure the voltages at the leads of the active devices such as tubes, transistors, or integrated circuits. Any voltage that does not come within at least 10% to 15% of the voltage specified on the schematic indicates either a problem with that device or a component connected with it in the circuit. The next step is to use the ohmmeter to narrow down the field of possible offenders.

To test a transistor, one lead of the ohmmeter is placed on the base; and the other lead placed just on the emitter, then on the collector. A normal transistor will read either high resistance (infinite), or little resistance (400 to 900 ohms), depending on the polarity of this type transistor. Then the leads should be switched, one remaining on the base, and the other switched from the emitter to the collector. Now the opposite condition should result: the resistance should be infinite if it was lower when the other lead was on the base. Consistently infinite readings indicate an open, and a short is demonstrated by 0-30 ohms on most of these test readings. Finally, place one lead on the collector, then the other on the emitter. No matter which lead is used, there should be infinite resistance. Any lower reading, such as 50 ohms (which is typical on a bad transistor), indicates a short.

This all sounds pretty confusing, but a little experience on a good transistor will make you an expert in no time. Usually, the lowest ohmmeter setting is used for testing transistors. Once in a great while a transistor may check out good on this test, but may actually be "leaky" or break down only on higher voltages. If in doubt, change it. It is also wise to check the transistor out of the circuit just in case some component in the circuit is affecting the ohmmeter reading.

A diode is tested like a transistor except it only has two leads. Again, there should be high resistance one

way and little resistance the other. If it tests bad, take one lead out of the circuit in case some component is messing up the ohmmeter reading.

NOTE: DO NOT leave soldering equipment on the leads too long since all semiconductors, especially integrated circuits, are easily destroyed by heat.

Without special equipment, integrated circuits are checked by verifying the proper DC voltage on the pins and the correct AC wave form using an oscilloscope. **BE CAREFUL:** Shorting their pins can easily destroy them.

Resistors are checked with an ohmmeter and should usually be within ten percent of the value stated on them and on the schematic. You may have to desolder one lead from the printed circuit board. If you wreck the foil on the board, carefully solder a small wire over the break to reconnect the conductive foil.

Capacitors are tricky. Their resistance goes up when checked with an ohmmeter which shows a charging action. As they suck up current from the meter, the voltage goes up and so does the resistance. If you are sure a particular circuit is giving you a problem and everything else checks out O.K., Electrolytic capacitors are prime suspects. Substitute a new one and keep your fingers crossed.

Theory of Operation

To understand what goes on inside the monitor, large general groups of circuits will be examined instead of laboriously analyzing the branches and small circuits that make up these groups. This will help avoid confusion and aid in a basic, concrete, knowledge of what makes up a monitor.

THE POWER SUPPLY —

The AC going to the monitor from the game transformer is just like the voltage and current from your wall outlet. It jumps up and down going positive and negative sixty times a second. But a monitor needs nice, smooth DC; direct current, not alternating. So diodes chop up the AC and a big electrolytic capacitor filters it out to make it even smoother. Since the monitor is a big piece of electronic equipment, with many circuits demanding a lot of power from the power supply, there are also zener diodes and transistors to help maintain a nice, constant, smooth voltage so that the monitor circuits don't jump around. And this is what happens when you see a wavy picture. There is AC creeping

through the power supply, so it must be malfunctioning. If the voltage from the power supply is too low, the other circuits will be starved for power and you may see a small, wavy picture, or none at all.

Some circuits receive voltages that are higher than what the power supply should put out. But they come from the flyback transformer which will be discussed later.

THE INTERFACE SECTION OF THE CHASSIS —

The interface section of the chassis is fairly easy to identify. It is right by the place where the video jack(s) from the logic board(s) plug into. There are sets of transistors that receive the separate red, green, blue, and sync information from the cables that come from the logic boards. The circuits jack up the voltage and match impedances, or in other words, prepare the logic board outputs for the circuits that will really amplify them for the output devices such as the yoke in the case of the sync, or the picture tube that shows the colors.

An interesting aside is that our sync is composite negative sync. That means two things:

1. The sync is a negative going wave form.
2. There are two pulses going at different speeds over the same wire:
 - a. Vertical wave forms at 60 times per second (or Hertz) and
 - b. Horizontal wave forms at about 15,750 times per second (Hz).

The sync is amplified by a sync amplifier transistor and sent on its way to the oscillators. The sync or timing information will be explained along with the oscillator shortly.

The color information is sent via wires to the neck board where the main amplification occurs. This will also be discussed later.

VERTICAL AND HORIZONTAL DEFLECTION —

After the sync signal is amplified by the sync amp, it goes to two different sections, the vertical and horizontal circuits. Basically, the sync signals are for timing so the picture doesn't mess up since it is assembled like an orderly jigsaw puzzle, but so fast that you can't see the electron beams for each color painting the picture on the screen. This will all become clear soon. For now, we will follow the 60 cycle component of the sync as it goes on its journey to the deflection yoke.

The 60 cycle pulse goes to the vertical oscillator to make sure this circuit goes back and forth (or oscillates) at 60 times a second. Without this pulse keeping the circuit at the correct speed, it may get lazy and oscillate at 58 cycles or lower, or get ambitious and oscillate at 62 cycles or higher. At the wrong speed, the picture will start to roll up or down.

A Wells Gardner 13" or 19" color monitor uses transistors for its sync section. An Electrohome 13" or 19" color monitor uses an integrated circuit IC501 for its sync section. The idea is all the same. The output to the vertical amplifying transistors for all monitors must be a sawtooth wave form, sort of like a bunch of pyramids, racing to the yoke's vertical coils at 60 times a second.

Along the way to the output transistors, the 60 cycle pulse is shaped and amplified to do the job: the yoke magnetically pushes the electron beam to fill the screen out sideways looking at the screen with the greatest length going up and down. Or viewing the screen sitting like a home television set. The amplified vertical output fills the screen up and down. Watching a monitor like this, seeing only a horizontal line means a problem with the vertical coils of the yoke or anything from the vertical output section on back to the oscillator.

The horizontal section is very similar with a few exceptions. The horizontal wave shape is more like a square and has a frequency of 15,750 cycles a second. Again, Wells Gardner uses transistors for the horizontal oscillator, and Electrohome uses the other side of IC501. Still, the effect is the same. If the oscillator isn't going at the correct speed, the picture may move sideways, start to slant, or tear up with slanted thin figures. With both the vertical and horizontal of all monitors, there are variable resistors that change the speed of the oscillators up and down. This way you have controls that can make the correct frequencies to keep the electronic jigsaw puzzle nicely locked in place. If you're driving in a car and next to you someone else is driving their car at exactly the same speed, it will appear that they are not moving. And this is why the sync frequency and the oscillators frequencies must match, so the picture doesn't appear to move.

The correct wave form is shaped and amplified in the circuitry just like in the vertical section. But the horizontal output transistor is a large power transistor and not only serves to give current to the horizontal yoke windings, it also feeds the flyback transformer.

THE FLYBACK TRANSFORMER (OR HIGH VOLTAGE UNIT) —

The picture tube needs high voltage to light up, and the power supply can't meet this demand. The flyback transformer receives current alternating at about 15,750 times per second from the horizontal output transistor. The "flyback" jacks up its input voltage and puts out a higher voltage alternating at the same speed. But, in your "flyback" there are diodes that chop up the alternating voltage to make it a smooth DC output just like in the power supply. This is what goes through that thick red wire to your picture tube. **THIS AREA HAS ABOUT 18,000 VOLTS ON IT AND IT CAN KILL YOU!!**

The "flyback" may be dangerous, but it is also generous. It has extra output windings which give voltage to the heater pins of the picture tube, voltage for the vertical deflection circuits, and picture tube screen-grid voltage. So in a way, the high voltage "flyback" is like a second power supply.

COLOR CIRCUITS

The color circuits are pretty straight forward. The signals go into the interface section where some amplification and impedance matching occurs. These circuits are pretty sparse and simple. Each color just has two transistors and a diode with some resistors and capacitors. From here, the AC color signal is sent by wires to the neck board.

The color output circuits are on the neck board. The color signals going to the transistors are controlled by two variable resistors called drive controls. There only two, one for the red and one for the green. The

blue doesn't have one. In the emitter part of each transistor is another variable resistor that is the cut off control. These controls vary the amount of amplified AC signal that goes to the cathodes of the picture tube. The more signal, the more color. The bases of each of these transistors are connected together and are all connected to the blanking and beam limiting transistors which are in the interface section.

The beam limiter helps control the brightness level, and the blanking transistor rapidly turns the picture tube on and off so that retrace lines don't show up on the screen. By turning up the brightness on a good monitor, these four to six retrace lines can be seen slanting diagonally across the picture.

PROTECTION CIRCUIT —

To protect the high voltage section against voltages that are too high coming from the power supply which could cause X-rays to be emitted from the "flyback", a circuit senses the higher power supply voltage, and using a transistor, turns off the horizontal oscillator. Since the horizontal oscillator doesn't work, the horizontal output transistor has nothing to feed the "flyback" which in turn has nothing to feed the picture tube. The monitor will be silent, have no picture, and will appear to be off. **But don't be fooled.** There is still that excessive amount of voltage coming from the power supply. To find out, check the emitter on TR502 of the Wells Gardner monitors; or the emitter of X04 for the Electrohome monitor. Here are the voltages you should receive:

Wells Gardner = 127VDC
Electrohome = 120VDC

The best place to measure this voltage on an Electrohome monitor is at a pin marked B1 on the chassis. This is because a 13 inch color Electrohome

monitor, the G07-FB0 or G07-902, has an integrated circuit and very little else in the power supply. Still, there should be 120VDC at B1

THE PICTURE TUBE (OR CRT) —

The picture tube or CRT is an output device. In other words, the end result of the circuits work is displayed by this part. Actually, the output of other circuits is in the neck of the picture tube.

First, there is the heater. The heater boils off electrons from the cathodes so that they (the electrons) shoot up to the screen to excite the phosphors so that the three phosphors emit three colors of light.

The cathodes are next, and again they emit electrons to turn on the tube phosphors, making it glow. The cathode can arc or short to the heater resulting in no picture and a defective picture tube.

Next come the grids. The first grid is grounded. The following grid is the screen grid which receives about 300VDC depending on the brightness setting. The next grid closest to the picture tube screen is the focus grid which gets about one fifth the amount of voltage that is applied to the picture tube anode.

After jetting from the cathode through all these grids, the electrons speed through a mask, a sheet of material with tiny holes, and then excite the tiny dots of phosphor in the inside surface of the picture tube screen. The green electron gun (or cathode and circuitry) spits out electrons which head for the green phosphors only. The same goes for the red and blue guns. The way the phosphor light blends determines the color seen. Should these electron beams become too intense, they may burn the phosphor. With the monitor off, this can be seen as a dark permanent image of the video information on the tube screen.

Differences Between Monitors

The easiest way to identify the brand of monitor you are working with, assuming you can't find the brand name written on it anywhere, is to see if there are two circuit boards rising up from the chassis toward the picture tube neck. In other words, they stand up, or are perpendicular to the chassis, with a black plastic bracket holding them in place. This is a description of a Wells Gardner monitor. They use separate boards for main chunks of circuitry. Therefore, you have a "power board" (the power supply), an "interface board" (the interface section), and a "horizontal/vertical board" (for the deflection circuitry). Still, there are a few parts on the chassis, but most can be found on the board. An Electrohome monitor has no

separate boards, except for the neck board, and just has a flat chassis.

Another good way to determine which monitor you have is to check the transistor call out numbers that are printed on the chassis next to the part. For instance, on the neck board, one of the color output transistors is TR401. If you look through the schematics or the parts lists, you will find TR401 in the Wells Gardner literature. On the other hand, the neck board transistor may say X101. X101 can be found in the Electrohome literature. So, all Wells Gardner transistor call outs begin with TR, and Electrohome transistor call outs start with an "X".

Parts Interchangeability

Some parts can be interchanged on all of the monitors. Here are the rules:

1. You **CAN** swap the voltage regulator TR502 or X01 on any Wells Gardner or Electrohome 19 inch monitor. You **CAN NOT** swap the voltage regulator on the 13 inch Wells Gardner or Electrohome (G07-902) since the Electrohome uses an integrated circuit for the power supply.
2. You **CAN** swap any resistor between monitors that has the same resistance, wattage rating, and tolerance.
3. You **CAN** swap any capacitor between monitors that has the same capacitance, and voltage rating.
4. **PICTURE TUBES:**
Due to the fact that "ELECTROHOME" is now (October, 1981) using a picture tube with an **internal shield**, these picture tubes can be used in EITHER "WELLS GARDNER" or "ELECTRO-HOME" monitors.

However, a "WELLS GARDNER" picture tube can **ONLY** be used in a "WELLS GARDNER" monitor. It will not function properly if installed in an "ELECTROHOME" monitor. The picture purity will be off.

5. You **CAN NOT** change any part that is a **safety part**, one that is shaded in gray on the schematic; it **MUST** be **IDENTICAL** to the original. **To do otherwise IS DANGEROUS.** For instance, the 13 inch Electrohome (G07-904) monitor "flyback" looks identical to the 19 inch Electrohome (G07-904) monitor "flyback". In fact, there is even a 19 inch Electrohome (G07-905) monitor (which is an obsolete model) with a similar looking "flyback". **NONE OF THESE ARE INTERCHANGEABLE!!**
6. You **CAN** change any of the parts between the G07-904 and G07-907. They're essentially the same monitor except that the G07-907 has a vertically mounted picture tube.

If there is any doubt about what parts can be swapped between each manufacturer's 19 inch and 13 inch models, compare the manufacturer's part number between each one. If they match up, they are the same part.

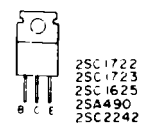
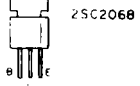
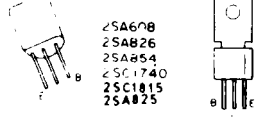
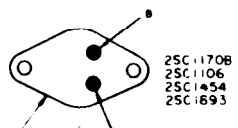
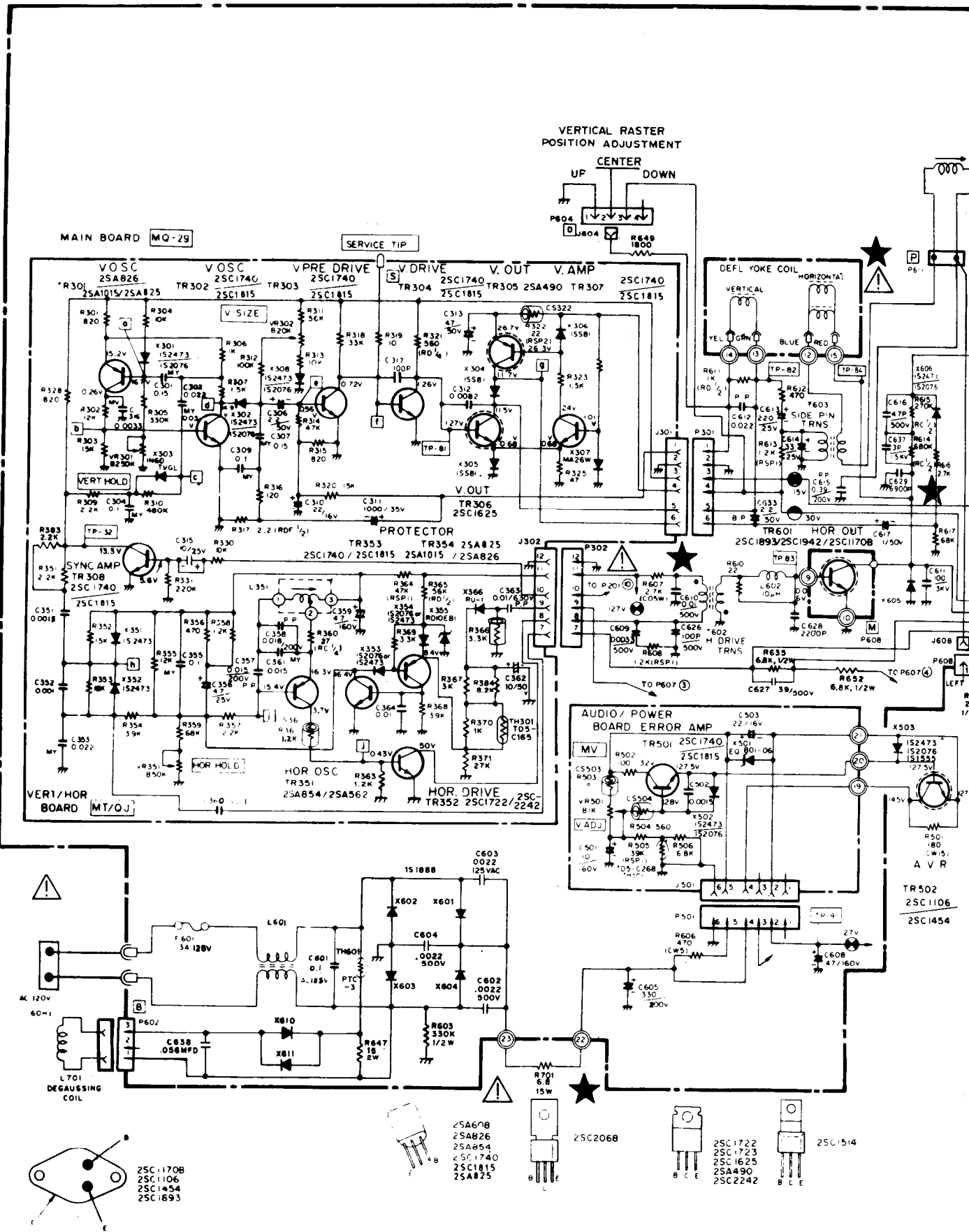

FOR MONITOR SCHEMATIC DIAGRAM

-00087-A012

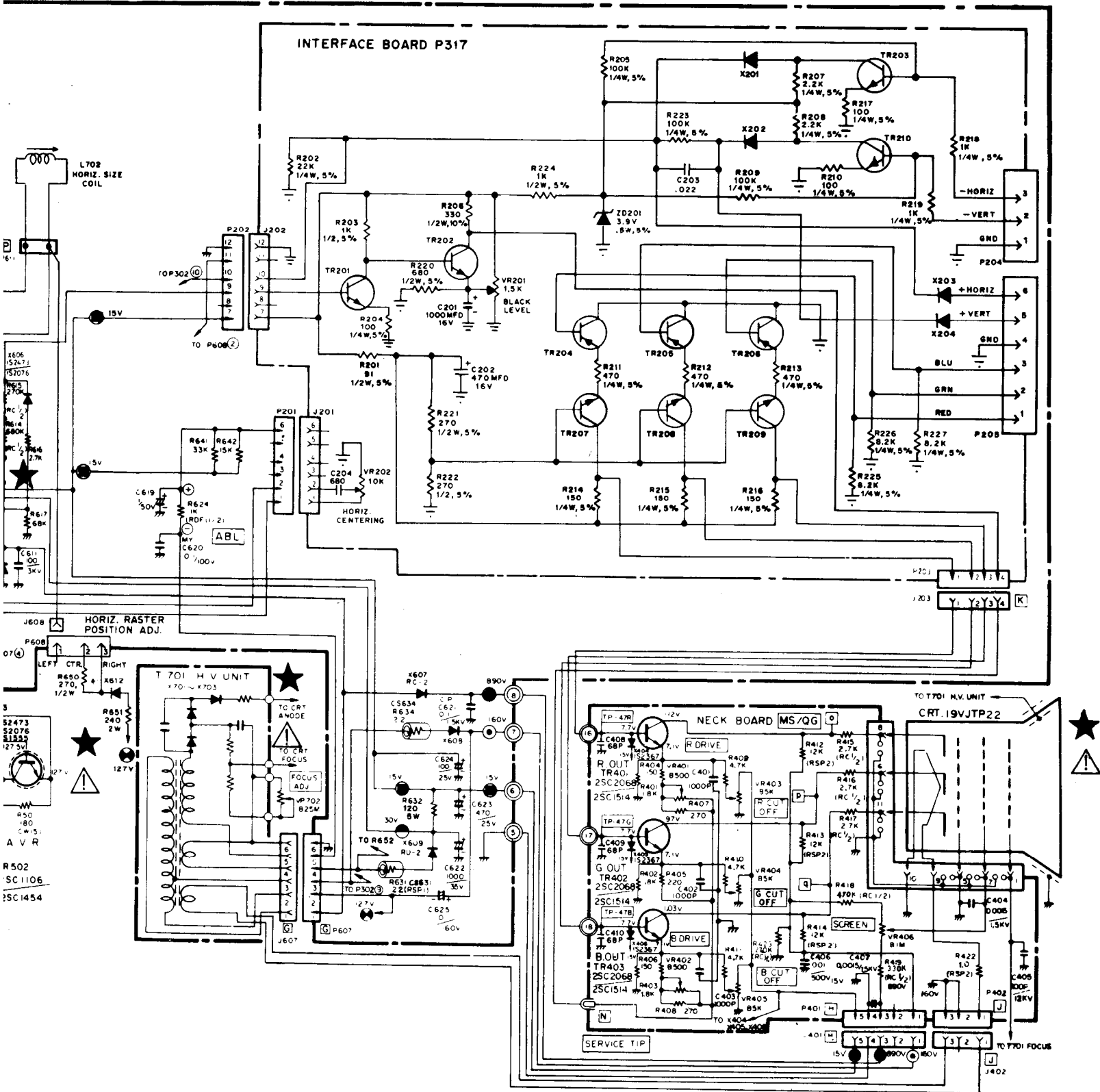

K4625A, K4626A, K4675A - 5816

NECK BOARD (MS/QG)

Ref. No.	Part No.	Description	Ref. No.	Part No.	Description
RESISTORS					
R401	203X6500-709	1.8k Ohm ± 5% 1/8W Carbon	C403	202X7000-247	1000 pF, 50V, 10% Ceramic
R402	203X6500-709	1.8k Ohm ± 5% 1/8W Carbon	C404	202X7110-019	1500 pF, 2kV ± 10% Ceramic
R403	203X6500-709	1.8k Ohm ± 5% 1/8W Carbon	C405	202X7150-018	100 pF, 12kV, ± 10% Ceramic
R404	203X6500-447	150 Ohm ± 5% 1/8W Carbon	C406	202X7050-483	.01 uF, 500V, ± 10% Ceramic
R405	203X6500-481	220 Ohm ± 5% 1/8W Carbon	C407	202X7110-019	1500 pF, 2kV ± 10% Ceramic
R406	203X6500-447	150 Ohm ± 5% 1/8W Carbon	C408	202X8000-550	68 pF, 50V, ± 10% Ceramic
R407	203X6500-508	270 Ohm ± 5% 1/8W Carbon	C409	202X8000-550	68 pF, 50V, ± 10% Ceramic
R408	203X6500-508	270 Ohm ± 5% 1/8W Carbon	C410	202X8000-550	68 pF, 50V, ± 10% Ceramic
R409	203X6500-800	4.7k Ohm ± 5% 1/8W Carbon			
R410	203X6500-800	4.7k Ohm ± 5% 1/8W Carbon			
R411	203X6500-800	4.7k Ohm ± 5% 1/8W Carbon			
R412	203X9104-809	12k Ohm ± 5% 2.0W Metal Oxide			
R413	203X9104-809	12k Ohm ± 5% 2.0W Metal Oxide			
R414	203X9104-809	12k Ohm ± 5% 2.0W Metal Oxide			
R415	203X5601-313	2.7k Ohm ± 10% 1/2W Comp.	TR401	200X3206-800	Transistor, 2SC2068, 2SC1514 (R output)
R416	203X5601-313	2.7k Ohm ± 10% 1/2W Comp.	TR402	200X3206-800	Transistor, 2SC2068, 2SC1514 (G output)
R417	203X5601-313	2.7k Ohm ± 10% 1/2W Comp.	TR403	200X3206-800	Transistor, 2SC2068, 2SC1514 (B output)
R418	203X5602-254	470k Ohm ± 10% 1/2W Comp.			
R419	203X5602-185	330k Ohm ± 10% 1/2W Comp.	X404	201X2100-126	Diode, IS2367 (protector)
R422	203X9105-117	1.0 Ohm ± 10% 2W Metal Oxide	X405	201X2100-126	Diode, IS2367 (protector)
R423	203X5102-155	270k Ohm ± 5% 1/4W Carbon	X406	201X2100-126	Diode, IS2367 (protector)
VR401	204X2115-014	500 Ohm Varistor R Drive			
VR402	204X2115-014	500 Ohm Varistor B Drive			
VR403	204X2115-006	5k Ohm Varistor R Cutoff			
VR404	204X2115-006	5k Ohm Varistor G Cutoff			
VR405	204X2115-006	5k Ohm Varistor B Cutoff			
VR406	204X2000-025	1M Ohm Varistor Screen			

SEMICONDUCTORS

MISCELLANEOUS

Ref. No.	Part No.	Description	Ref. No.	Part No.	Description
CAPACITORS					
C401	202X7000-247	1000 pF, 50V, 10% Ceramic	J401	206X5003-729	Socket, 5 Pin
C402	202X7000-247	1000 pF, 50V, 10% Ceramic	J402	206X5003-983	Socket, 3 Pin
			P401	204X9600-329	Plug, 5 Pin
			P402	204X9600-254	Plug, 3 Pin

★ 297X2000-072 HIGH VOLTAGE ASSEMBLY (T701)

FINAL ASSEMBLY PARTS

★ R701	204X1625-058	3.3 Ohm, ± 10% 10W WW Resistor	★ 88X-0129-506	19VJTP22 Pix Tube
VR702	204X3901-125	Focus Control	38A5554-000	Assy. Purity Shld/Degaussing
X701		Diode (SI HV) } Part of T701	205X9800-256	Lateral/Purity Assembly
X702		Diode (SI HV) }	★ 202X1110-810	Yoke, Deflection
X703		Diode (SI HV) }	208X2000-946	CRT Socket
			297X2000-072	HV Unit (T701)
			6A0397	Plug, Line Cord
			9A2753-003	Degaussing Coil (L701)

INTERFACE BOARD (P305) (MODEL 19K4606)

Ref. No.	Part No.	Description	Ref. No.	Part No.	Description
RESISTORS					
R201	340X3910-934	91 Ohm, 5%, 1/2W Carbon	TR201	86X0121-001	Transistor (NPN)
R203	340X3102-934	1k Ohm, 5%, 1/2W Carbon	TR202	86X0121-001	Transistor (NPN)
R204	340X2101-934	100 Ohm, 5%, 1/4W Carbon	TR203	86X0121-001	Transistor (NPN)
R206	340X3331-944	330 Ohm, 10%, 1/2W Carbon	TR204	86X0066-001	Transistor (PNP)
R207	340X3102-934	1k Ohm, 5%, 1/2W Carbon	TR205	86X0066-001	Transistor (PNP)
R208	340X3152-934	1.5k Ohm, 5%, 1/4W Carbon	TR206	86X0066-001	Transistor (PNP)
R209	340X2101-934	100 Ohm, 5%, 1/4W Carbon	TR207	86X0121-001	Transistor (NPN)
R210	340X3102-934	1k Ohm, 5%, 1/2W Carbon	TR208	86X0121-001	Transistor (NPN)
R211	340X2331-934	330 Ohm, 5%, 1/4W Carbon	TR209	86X0121-001	Transistor (NPN)
R212	340X2331-934	330 Ohm, 5%, 1/4W Carbon	ZD201	66X0040-018	Diode, Zener, 6.8v, 5%, 0.5W
R213	340X2331-934	330 Ohm, 5%, 1/4W Carbon	ZD202	66X0040-019	Diode, Zener, 3.9v, 5%, 0.5W
R214	340X2201-934	200 Ohm, 5%, 1/4W Carbon			
R215	340X2201-934	200 Ohm, 5%, 1/4W Carbon			
R216	340X2201-934	200 Ohm, 5%, 1/4W Carbon			
VR201	40X0590-017	1.5k Ohm, Black Level Control			
CAPACITORS					
C201	45X0524-038	1000 uF, 16V Electrolytic	J201	204X9300-958	Socket, 6 Pin
			J202	204X9300-958	Socket, 6 Pin
			J203	206X5019-207	Socket, 4 Pin
			P201	204X9601-195	Plug, 6 Pin
			P202	204X9601-195	Plug, 6 Pin
			P203	204X9600-845	Plug, 4 Pin
			P205	6A0393-006	Plug, 6 Pin
SEMICONDUCTORS					
MISCELLANEOUS					

VERT/HOR BOARD (MT/QJ)

Ref. No.	Part No.	Description	Ref. No.	Part No.	Description
RESISTORS			CAPACITORS (CONT.)		
R301	203X6500-628	820 Ohm, ± 5%, 1/8W Carbon	C313	203X0025-087	47 uF, 50V Electrolytic
R302	203X6500-902	12k Ohm, ± 5%, 1/8W Carbon	C315	203X0015-082	10 uF, 25V Electrolytic
R303	203X6500-927	15k Ohm, ± 5%, 1/8W Carbon	C316	203X1100-220	3300 uF, 50V, ± 10% Mylar
R304	203X6500-886	10k Ohm, ± 5%, 1/8W Carbon	C317	202X8000-616	100 pF, 50V, ± 10% Ceramic
R305	203X6501-241	330k Ohm, ± 5%, 1/8W Carbon	C351	202X7000-281	1500 pF, 50V, ± 10% Ceramic
R306	203X6500-645	1k Ohm, ± 5%, 1/8W Carbon	C352	202X7000-247	1000 pF, 50V, ± 10% Ceramic
R307	203X6500-689	1.5k Ohm, ± 5%, 1/8W Carbon	C353	203X1100-573	0.022 uF, 50V, ± 10% Mylar
R309	203X6500-724	2.2k Ohm, ± 5%, 1/8W Carbon	C355	203X1100-858	0.1 uF, 50V, ± 10% Mylar
R310	203X6501-285	470k Ohm, ± 5%, 1/8W Carbon	C356	203X0015-105	4.7 uF, 25V Electrolytic
R311	203X6501-065	56k Ohm, ± 5%, 1/8W Carbon	C357	203X1201-013	0.015uF, 200V ± 10% PP
R312	203X6501-126	100k Ohm, ± 5%, 1/8W Carbon	C358	203X1201-034	0.018 uF, 200V, ± 10% PP
R313	203X6001-326	10k Ohm, ± 5%, 1/8W Carbon	C359	203X0040-013	4.7 uF, 160V Electrolytic
R314	203X6501-044	47k Ohm, ± 5%, 1/8W Carbon	C360	202X7000-482	0.01 uF, 50V, ± 10% Ceramic
R315	203X6500-628	820 Ohm, ± 5%, 1/8W Carbon	C361	203X1100-509	0.015 uF, 50V, ± 10% Mylar
R316	203X6500-420	120 Ohm, ± 5%, 1/8W Carbon	C362	203X0025-058	10 uF, 50V Electrolytic
R317	203X6206-441	2.2 Ohm, ± 5%, 1/2W Carbon	C363	203X1205-487	0.01 uF, 630V, ± 10% PP
R319	203X6500-169	100 Ohm, ± 5%, 1/8W Carbon	C364	202X7000-482	0.01 uF, 50V, ± 10% Ceramic
R320	203X6500-927	15k Ohm, ± 5%, 1/8W Carbon			
R321	203X6700-509	560 Ohm, ± 5%, 1/2W Carbon			
R322	203X9100-121	22 Ohm, ± 5%, 2W M.O.			
R323	203X6500-689	1.5k Ohm, ± 5%, 1/8W Carbon			
R324	203X6500-988	27k Ohm, ± 5%, 1/8W Carbon	TR301	200X4082-614	Transistor, 2SA826Q
R325	203X6500-326	47 Ohm, ± 5%, 1/8W Carbon	TR302	200X3174-006	Transistor, 2SC1740Q
R328	203X6500-628	820 Ohm, ± 5%, 1/8W Carbon	TR303	200X3174-006	Transistor, 2SA1740Q
R330	203X6500-886	10k Ohm, ± 5%, 1/8W Carbon	TR304	200X3174-006	Transistor, 2SC1740Q
R331	203X6501-209	220k Ohm, ± 5%, 1/8W Carbon	TR305	200X4049-081	Transistor, 2SA490YLBGLI
R351	203X6500-724	2.2k Ohm, ± 5%, 1/8W Carbon	TR306	200X3162-538	Transistor, 2SC1625YLBGLI
R352	203X6500-927	15k Ohm, ± 5%, 1/8W Carbon	TR307	200X3174-014	Transistor, 2SC1740R
R353	203X6500-944	18k Ohm, ± 5%, 1/8W Carbon	TR308	200X3174-006	Transistor, 2SC1740Q
R354	203X6500-763	3.9k Ohm, ± 5%, 1/8W Carbon	TR351	200X4085-415	Transistor, 2SA854Q
R355	203X6500-902	12k Ohm, ± 5%, 1/8W Carbon	TR352	200X3172-208	Transistor, 2SC1722BKS
R356	203X6500-551	470 Ohm, ± 5%, 1/8W Carbon	TR353	200X3174-006	Transistor, 2SC1740Q
R357	203X6500-724	2.2k Ohm, ± 5%, 1/8W Carbon	TR354	200X4082-614	Transistor, 2SA826Q
R358	203X6500-666	1.2k Ohm, ± 5%, 1/8W Carbon	X301	201X2010-144	Diode, (Si) IS2473-T72
R359	203X6501-088	68k Ohm, ± 5%, 1/8W Carbon	X302	201X2010-144	Diode, (Si) IS2473-T72
R360	203X5500-471	27 Ohm, ± 5%, 1/4W Comp.	X303	200X8000-026	Diode, (Ge), IN60TVGL
R361	203X6000-998	1.2k Ohm, ± 5%, 1/8W Carbon	X304	200X8010-165	Diode (Si) ISS81
R363	203X6500-666	1.2k Ohm, ± 5%, 1/8W Carbon	X305	201X2010-165	Diode (Si) ISS81
R364	203X9014-988	47k Ohm, ± 5%, 1W M.O.	X306	201X2010-165	Diode (Si) ISS81
R365	203X6700-989	56k Ohm, ± 5%, 1/2W Carbon	X307	200X8010-102	Diode (Si) MA26W
R366	203X6001-148	3.3k Ohm, ± 5%, 1/8W Carbon	X308	200X8010-094	Diode (Si) IS2473
R367	340X2222-734	2.2k Ohm, ± 5%, 1/2W Carbon	X351	201X2010-144	Diode (Si) IS2473-T72
R368	203X6500-785	3.9k Ohm, ± 5%, 1/8W Carbon	X352	201X2010-144	Diode (Si) IS2473-T72
R369	203X6500-762	3.3k Ohm, ± 5%, 1/4W Carbon	X353	201X2010-144	Diode (Si) IS2473-T72
R370	302X6100-961	1k Ohm, ± 5%, 1/4W Carbon	X354	201X2010-144	Diode (Si) IS2473-T72
R371	203X6104-751	2.7k Ohm, ± 5%, 1/4W Carbon	X355	200X8220-851	Diode (Zener) RD10EBI
VR301	204X2122-093	Varistor, 250K Ohm, Vert. Hold	X366	200X8100-130	Diode (HS) RU-1 0.3 US
VR302	204X2114-065	Varistor, 20K Ohm, Vert. Size			
VR351	204X2114-059	Varistor, 50K Ohm, Hor. Hold			
CAPACITORS			MISCELLANEOUS		
C301	203X1100-928	0.15 uF, 50V, ± 10% Mylar	J301	204X9300-958	Socket, 6 Pin
C302	203X1100-573	0.022 uF, 50V, ± 10% Mylar	J302	204X9300-958	Socket, 6 Pin
C304	203X1100-858	0.1 uF, 50V, ± 10% Mylar	P301	204X9601-195	Plug, 6 Pin
C306	203X0025-026	2.2 uF, 50V, Electrolytic	P302	204X9601-195	Plug, 6 Pin
C307	203X1100-928	0.15 uF, 50V, ± 10% Mylar	TH301	201X0000-534	Thermistor
C309	203X1100-858	0.1 uF, 50V, ± 10% Mylar			
C310	203X0010-011	22 uF, 16V Electrolytic			
C311	203X0020-099	1000 uF, 35V Electrolytic			
C312	202X7000-469	0.0082 uF, 50V, ± 10% Ceramic	L351	201X5200-091	Coil, Horiz. Osc.
POWER BOARD (MV)			TRANSFORMERS & COILS		
			C503	203X0010-011	22 uF, 16V Electrolytic
			C551	203X0005-046	220 uF, 10V Electrolytic
R501	204X1725-052	180 Ohm, ± 10%, 15W WW			
R502	203X6000-608	100 Ohm, ± 5%, 1/8W Carbon			
R503	203X6000-960	1k Ohm, ± 5%, 1/8W Carbon			
R504	203X6000-879	560 Ohm, ± 5%, 1/8W Carbon	TR501	200X3174-006	Transistor, 2SC1740Q
R505	203X9014-965	39k Ohm, ± 5%, 1W M.O.	★ TR502	200X3145-404	Transistor, 2SC1454
R506	203X6500-842	6.8k Ohm, ± 5%, 1/8W Carbon	TR551	200X3172-305	Transistor, 2SC1723
R551	203X6500-420	120 Ohm, ± 5%, 1/8W Carbon	X501	201X2230-042	Diode, (Si) Zener EQB01-06V
VR501	204X2050-001	Varistor Vert. Adj.	X502	201X2010-144	Diode, (Si) IS2473-T72
CAPACITORS			MISCELLANEOUS		
C501	203X0040-020	10 uF, 160V Electrolytic	J501	204X9300-958	Socket, 6 Pin
C502	202X7000-281	1500 pF, 50V, ± 10% Ceramic	P501	204X9601-195	Plug, 6 Pin
			TH501	201X0000-618	Thermistor

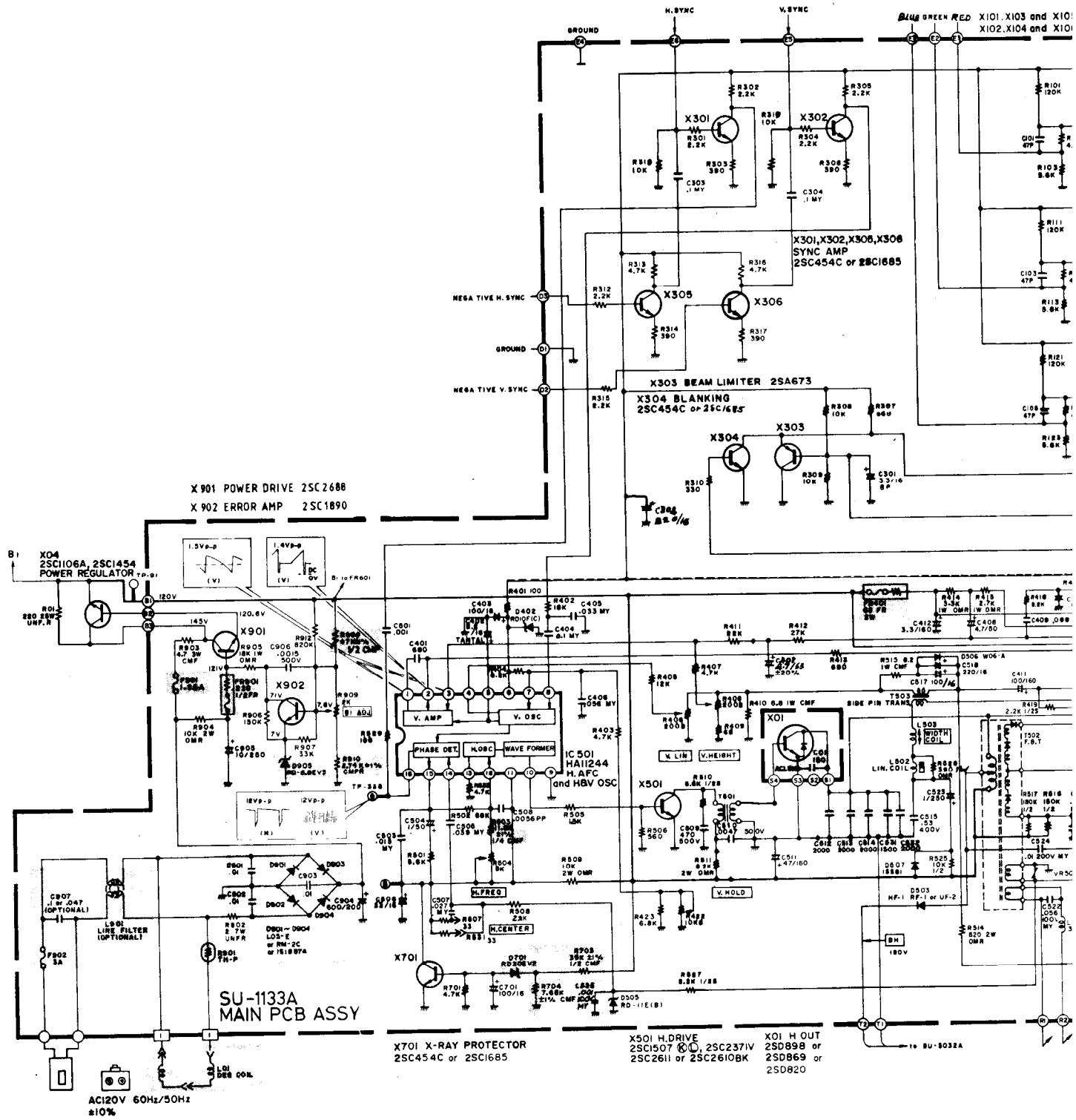

X101, X103 and X105 VIDEO AMP: 2SC454C
 X102, X104 and X106 VIDEO AMP: 2SA673C

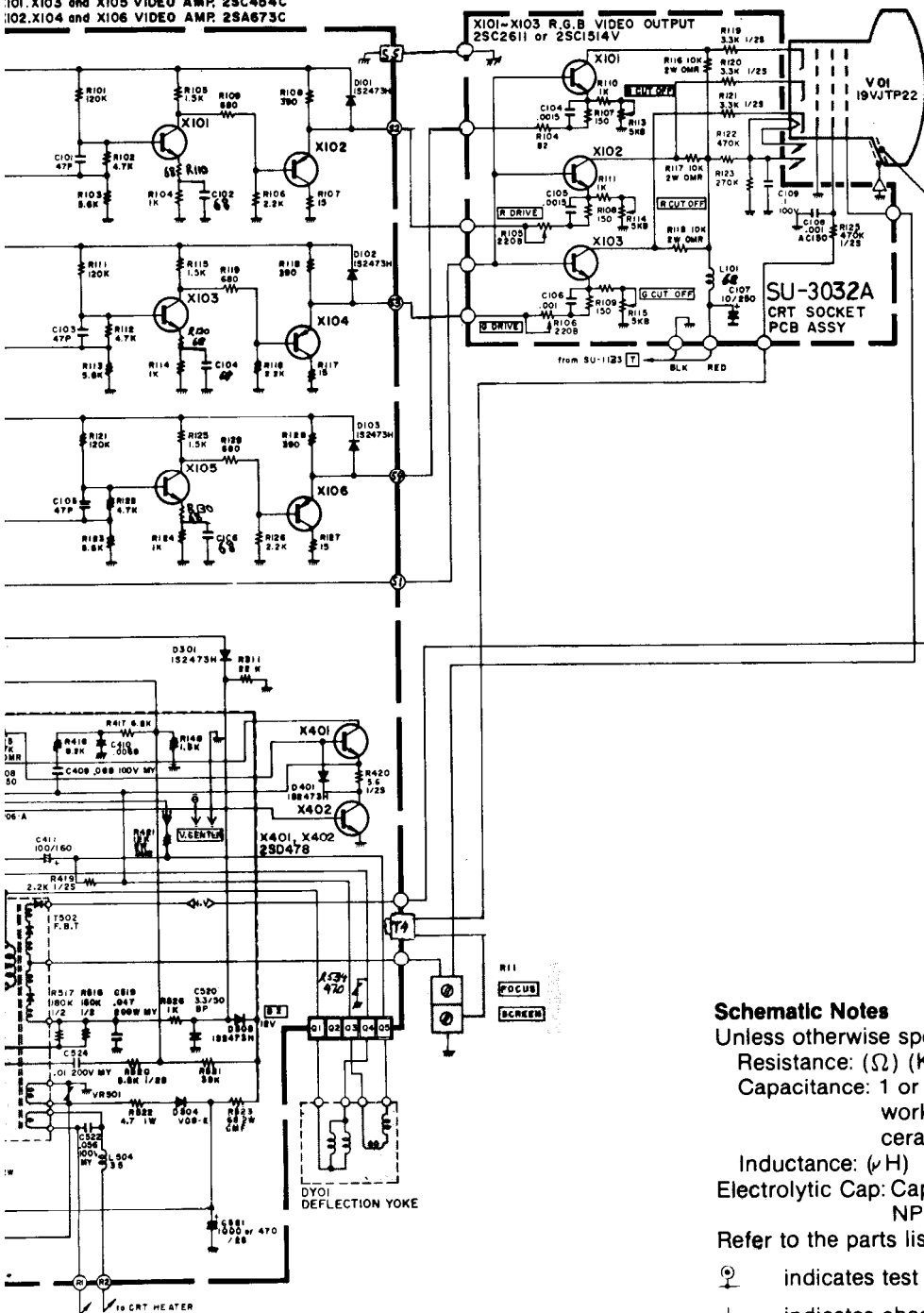

Schematic Notes

Unless otherwise specified

Resistance: (Ω) (K \rightarrow K Ω , M \rightarrow M Ω), 1/4 (W) carbon resistor

Capacitance: 1 or higher \rightarrow (pF), less than 1 \rightarrow (μ F)

working voltage \rightarrow 50 (V)

ceramic capacitor

Inductance: (μ H)

Electrolytic Cap: Capacitance Value (μ F)/working voltage (V),

NP \rightarrow non-polar (or bipolar) electrolytic cap.

Refer to the parts list for additional component information.

$\text{\textcircled{P}}$ indicates test point connection

$\text{\textcircled{G}}$ indicates chassis ground unless otherwise specified

Hz indicates cycles per second

For **safety** purposes (and continuing reliability)

$\text{\textcircled{\Delta}}$ replace all components marked with safety symbol with identical type.

NOTE: FR \rightarrow fusible resistor ($\text{\textcircled{FR}}$)

00-4147-04
 G07-CB0

Parts identification on circuit boards:

e.g. SU1126A (R107 = R1107)

SU3030A (R113 = R3113)

Outside of the P.C.B. Ass'y

Symbol	Description	Part Number
	Picture Tube 19"	17-7198-03
△	△Deflection Yoke	A29779-D = 21-141-01
	PC Magnet	A75034-B = 29-32-01
△	△Flyback Transf.	A29951-B
△	△HVR	A46600-A
R05	UNF Resistor 220Ω, 25W K	QRF258K-221
C04	C Capacitor 150pF, AC1.5KV	QCZ0101-005
X01	Si. Transistor	2SD870
X02	Si. Transistor	2SC1106A
SC	Screw #8- ³ / ₈	31-610818-06
SC	Screw 1/4 x 3/4 Pix Tube Mtg. (4)	31-601418-12
WA	Pyramidal Lock Washer (4)	33-255-01
	Nut Retainer, Pix Tube Mtg. (4)	33-494-01
	Clip — P.C.B. Support	33-629-02
	Standoff	33-670-010R-02
	Wire Terminal (Gnd. Strap)	34-228-03
	Terminal Lug (Gnd.)	34-33-04
	Groundstrap Assy.	34-574-02
	Grounding Spring	35-212-03
	Wire Hook (Gnd. Strap)	35-3053-02
	Purity Shield Holddown Clamp	35-2348-01
	Support Brkt. RH	35-3890-01
	Support Brkt. LH	35-3890-02
	Chassis Base	38-449-02
	Yoke Wedge (3)	39-1233-01

Purity Shield Ass'y. Parts List

Symbol	Description	Part Number
D911, D912	Degaussing Coil	21-1007-30
	Rectifier 1 Amp 600V (2)	28-22-27
	Pin Terminal (2)	34-708-01
	Pin Terminal Housing	34-709-01
	Purity Shield (2 pcs.)	35-3847-01
	Purity Shield (2 pcs.)	35-3847-02
C911	Capacitor 100nF 10% 400V	48-171544-62
R921	Resistor, Wirewound 33Ω, 4W	42-113301-03
	Fire Retardent Term. Strip 4 Lug	34-492-09

CRT Socket P.C.B. Ass'y (SU-3032A) Parts List

Resistors

Symbol	Description	Part Number
R3105	V R 200	QVZ3234-022
R3106	V R 200	QVZ3234-022
R3113	V R 5K	QVZ3234-053
R3114	V R 5K	QVZ3234-053
R3115	V R 5K	QVZ3234-053
R3116	OM R 10KΩ2W J	QRG029J-103
R3117	OM R 10KΩ2W J	QRG029J-103
R3118	OM R 10KΩ2W J	QRG029J-103
R3119	Comp. R 3.3KΩ ¹ / ₂ W K	QRZ0039-332
R3120	Comp. R 3.3KΩ ¹ / ₂ W K	QRZ0039-332
C3121	Comp. R 3.3KΩ ¹ / ₂ W K	QRZ0039-332

Capacitors

Symbol	Description	Part Number
C3107	E Cap. 10uF 250V A	QEW53EA-106
C3108	C Cap. 1000pF DC1400V P	QCZ9001-102M

Coils

Symbol	Description	Part Number
L3101	Peaking Coil	QLL043K-101

REPLACEMENT PARTS LIST - ELECTROHOME 19" MONITOR

Components identified by the Δ symbol in the PARTS LIST and on the Schematic have special characteristics important to safety.

DO NOT degrade the safety of the set through improper servicing.

Abbreviations for Resistors and Capacitors

Resistor

C R	: Carbon Resistor
Comp. R	: Composition Resistor
OM R	: Oxide Metal Film Resistor
V R	: Variable Resistor
MF R	: Metal Film Resistor
CMF R	: Coating Metal Film Resistor
UNF R	: Nonflammable Resistor
F R	: Fusible Resistor

Capacitor

C Cap.	: Ceramic Capacitor
M Cap.	: Mylar Capacitor
E Cap.	: Electrolytic Capacitor
BP E Cap.	: Bi-Polar (or Non-Polar) Electrolytic Capacitor
MM Cap.	: Metalized Mylar Capacitor
PP Cap.	: Polypropylene Capacitor
MPP Cap.	: Metalized PP Capacitor
PS Cap	: Polystyrol Capacitor
Tan. Cap.	: Tantal Capacitor

NOTE: When ordering replacement parts please specify the part number as shown in this list including part name, and model number. Complete information will help expedite the order.

Use of substitute replacement parts which do not have the same safety characteristics as specified, may create shock, fire or other hazards. For maximum reliability and performance, all parts should be replaced by those having identical specifications.

SERVICE REPLACEMENT PARTS LIST

Symbol	Description	Part Number
	Main P.C.B. Ass'y	SU-1133A
	CRT Socket P.C.B. Ass'y	SU-3032A
	Purity Shield Ass'y	07-220083-03

Outside of the P.C.B. Ass'y

Symbol	Description	Part Number
△	Picture Tube 19'	17-7198-03
△	△Deflection Yoke	A29779-D = 21-141-01
△	PC Magnet	A75034-B = 29-32-01
△	△Flyback Transf.	A29951-B
△	△HVR	A46600-A
R05	UNF Resistor 220Ω, 25W K	QRF258K-221
C04	C Capacitor 150pF, AC1.5KV	QCZ0101-005
X01	Si. Transistor	2SD870
X02	Si. Transistor	2SC1106A
SC	Screw #8-3/8	31-610818-06
SC	Screw 1/4 x 3/4 Pix Tube Mtg. (4)	31-601418-12
WA	Pyramidal Lock Washer (4)	33-255-01
	Nut Retainer, Pix Tube Mtg. (4)	33-494-01
	Clip — P.C.B. Support	33-629-02
	Standoff	33-670-010R-02
	Wire Terminal (Gnd. Strap)	34-228-03
	Terminal Lug (Gnd.)	34-33-04
	Groundstrap Assy.	34-574-02
	Grounding Spring	35-212-03
	Wire Hook (Gnd. Strap)	35-3053-02
	Purity Shield Holddown Clamp	35-2348-01
	Support Brkt. RH	35-3890-01
	Support Brkt. LH	35-3890-02
	Chassis Base	38-449-02
	Yoke Wedge (3)	39-1233-01

Purity Shield Ass'y. Parts List

Symbol	Description	Part Number
D911, D912	Degaussing Coil	21-1007-30
	Rectifier 1 Amp 600V (2)	28-22-27
	Pin Terminal (2)	34-708-01
	Pin Terminal Housing	34-709-01
	Purity Shield (2 pcs.)	35-3847-01
	Purity Shield (2 pcs.)	35-3847-02
C911	Capacitor 100nF 10% 400V	48-171544-62
R921	Resistor, Wirewound 33Ω, 4W	42-113301-03
	Fire Retardent Term. Strip 4 Lug	34-492-09

CRT Socket P.C.B. Ass'y (SU-3032A) Parts List

Resistors

Symbol	Description	Part Number
R3105	V R 200	QVZ3234-022
R3106	V R 200	QVZ3234-022
R3113	V R 5K	QVZ3234-053
R3114	V R 5K	QVZ3234-053
R3115	V R 5K	QVZ3234-053
R3116	OM R 10KΩ2W J	QRG029J-103
R3117	OM R 10KΩ2W J	QRG029J-103
R3118	OM R 10KΩ2W J	QRG029J-103
R3119	Comp. R 3.3KΩ1/2W K	QRZ0039-332
R3120	Comp. R 3.3KΩ1/2W K	QRZ0039-332
C3121	Comp. R 3.3KΩ1/2W K	QRZ0039-332

Capacitors

Symbol	Description	Part Number
C3107	E Cap. 10uF 250V A	QEW53EA-106
C3108	C Cap. 1000pF DC1400V P	QCZ9001-102M

Coils

Symbol	Description	Part Number
L3101	Peaking Coil	QQL043K-101

Semiconductors

Symbol	Description	Part Number
X3101	Si. Transistor	2SC1514VC
X3102	Si. Transistor	2SC1514VC
X3103	Si. Transistor	2SC1514VC

Miscellaneous

Symbol	Description	Part Number
△	△CRT Socket	A76068

Main PCB Ass'y (SU-1133A) Parts List**Resistors**

Symbol	Description	Part Number
R1406	V R 200Ω	QVZ3230-002
R1408	V R 200Ω	QVZ3230-002
R1410	CMF R 6.8Ω1W J	QRX019J-6R8
R1414	OM R 3.3KΩ1W J	QRG019J-332
R1415	OM R 2.7KΩ1W J	QRG019J-272
R1421	OM R 12KΩ2W J	QRG026J-123Z
R1422	V R 10KΩ	QVZ3230-014
△FR1401	△F R 68Ω2W K	QRH024K-680M
△R1503	△CMF R 11.8KΩ¼W +1%	QRV142F-1182
R1504	V R 5KΩ	QVZ3230-053
R1509	OM R 10KΩ2W J	QRG026J-103Z
R1512	OM R 8.2KΩ2W J	QRG026J-822Z
R1514	OM R 820Ω2W J	QRG026J-821Z
R1515	CMF R 8.2Ω1W J	QRX019J-8R2
R1522	CMF R 4.7Ω1W J	QRX019J-4R7
R1523	OM R 68Ω2W J	QRG026J-680Z
R1528	OM R 390Ω1W J	QRG019J-391
R1534	ZN R	ERZ-C05ZK471
VR1501	ZN R	ERZ-C05DK271
△R1703	△CMF R 39Ω½W +1%	QRV122F-3902
△R1704	△CMF R 7.68KΩ¼W +1%	QRV142F-7681
△R1901	△Posistor	A75414
R1902	UNF R 2Ω7W K	QRF076K-2R0
R1903	CMF R 4.7Ω3W J	QRX039J-4R7
R1904	OM R 10KΩ2W J	QRG026J-103Z
R1905	OM R 18KΩ1W J	QRG019J-183
△Q1908	△CMF R 47Ω½W +1%	QRV122F-470Z
△R1909	V R 2KΩ	QVP5A0B-023E
R1910	△CMF R 2.74KΩ¼W +1%	QRV142F-274I
△FR1901	△F R 220Ω½W K	QRH124K-221M

Capacitors

Symbol	Description	Part Number
C1301	BPE Cap. 3.3uF 50V A	QEN61HA-335Z
C1402	Tan. Cap. 2.2uF 16V K	QEE51CK-225B
C1407	E Cap. 4.7uF 6.3V A	QEW51JA-475
C1411	E Cap. 100uF 160V A	QEW52CA-107
C1412	E Cap. 3.3uF 160V A	QEW52CA-335
C1508	PP Cap. 5600uF 50V J	QFP31HJ-562
△C1512	△PP Cap. 2000pF DC1500V J	QFZ0082-202
△C1513	△PP Cap. 2000pF DC1500V J	QFZ0082-202
△C1514	△PP Cap. 2000pF DC1500V J	QFZ0082-202
C1515	PP Cap. 0.53uF DC1200V J	QFZ0067-534
C1520	BPE Cap. 3.3uF 50V A	QEN61HA-335Z
C1523	E Cap. 1uF 160V A	QEW62CA-105Z
C1524	M Cap. 0.1uF 200V K	QFM720K-104M
△C1531	△PP Cap. 2000pF DC1500V J	QFZ0082-202
△C1532	△PP Cap. 1500pF DC1500V J	QFZ0082-152
C1904	E Cap.	QEY0034-001
C1905	E Cap. 10uF 250V A	QEW52EA-106

Coils		
Symbol	Description	Part Number
L1502	Linearity Coil	A39835
L1503	Width Coil	C30380-A
L1504	Heater Choke	C30445-A
Transformers		
Symbol	Description	Part Number
T1501	Hor. Drive Transf.	A46022-BM
T1503	Side Pin Transf.	C39050-A
Semiconductors		
Symbol	Description	Part Number
IC1501	IC	HA11244
X1101	Si. Transistor	2SC1685(R)
X1102	Si. Transistor	2SA673(C)
X1103	Si. Transistor	2SC1685(R)
X1104	Si. Transistor	2SA673(C)
X1105	Si. Transistor	2SC1685(R)
X1106	Si. Transistor	2SA673(C)
X1301	Si. Transistor	2SC1685(R)
X1302	Si. Transistor	2SC1685(R)
X1303	Si. Transistor	2SA673(C)
X1304	Si. Transistor	2SC1685(R)
X1305	Si. Transistor	2SC1685(R)
X1401	Si. Transistor	2SD478
X1402	Si. Transistor	2SD478
X1501	Si. Transistor	2SC2610BK
X1901	Si. Transistor	2SC2688 (K.L.M.)
X1902	Si. Transistor	2SC1890A (E.F.)
D1101	Si. Diode	W06A
D1102	Si. Diode	W06A
D1103	Si. Diode	W06A
D1301	Si. Diode	1SZ473H
D1401	Si. Diode	1SZ473H
D1402	Zener Diode	RD10F(C)
D1503	Si. Diode	HF-1
D1504	Si. Diode	V09E
D1505	Zener Diode	RD11E(B)
D1506	Si. Diode	W06A
D1507	Si. Diode	1SS81
D1508	Si. Diode	1SZ473H
△D1701	△Zener Diode	RD20EV2
△D1901	△Si. Diode	1S1887A
△D1902	△Si. Diode	1S1887A
△D1903	△Si. Diode	1S1887A
△D1904	△Si. Diode	1S1887A
△D1905	△Zener Diode	RD6.8EV3
Miscellaneous		
Symbol	Description	Part Number
△F1901	△Fuse 1.25A	QMF53U1-1R25S
△F1902	△UL Fuse 3A	QMF66U1-3R0S

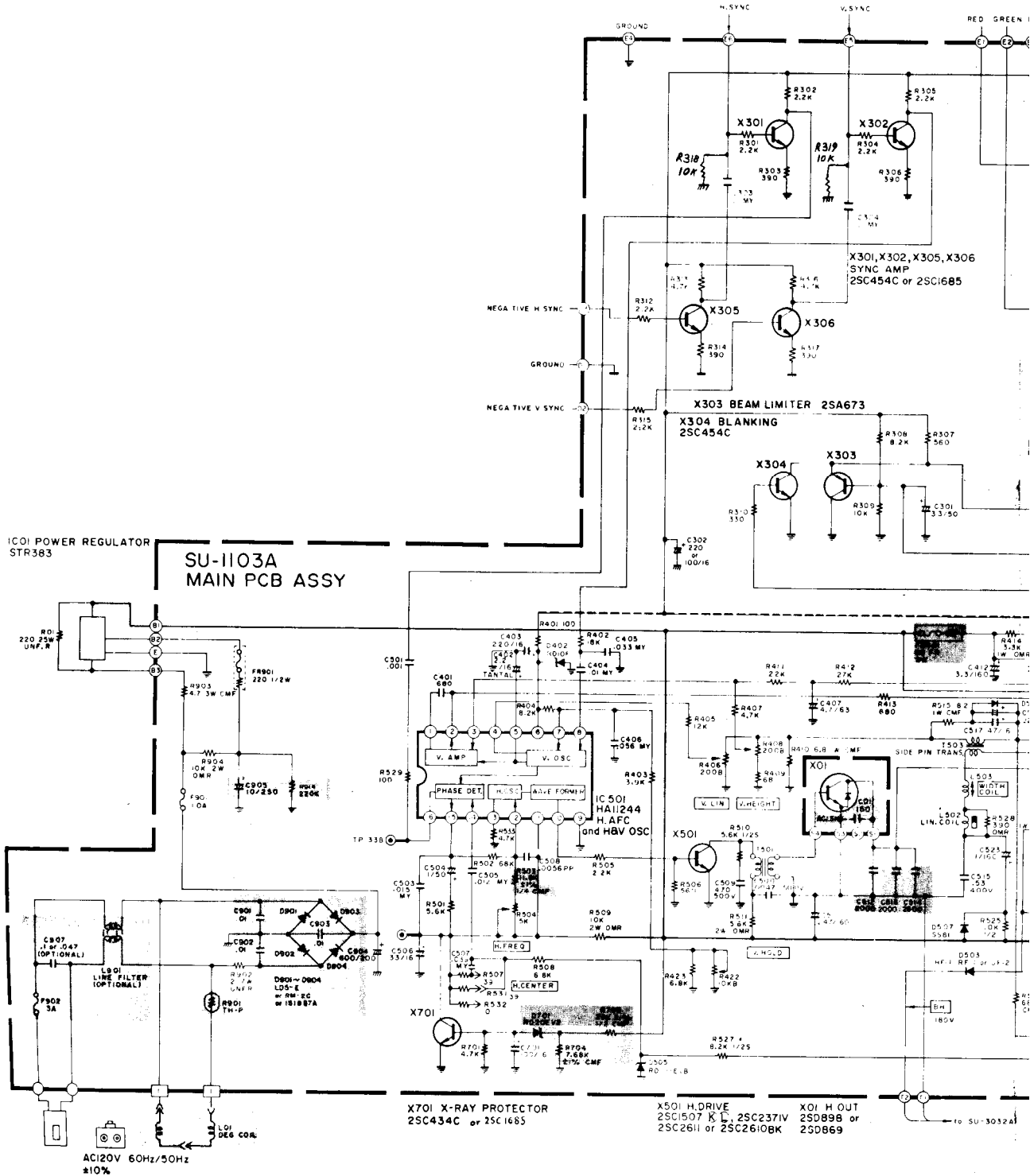

GREEN BLUE X101 X103 and X105 VIDEO AMP 25C454C or 25C1685
 X102, X104 and X106 VIDEO AMP 25A673C

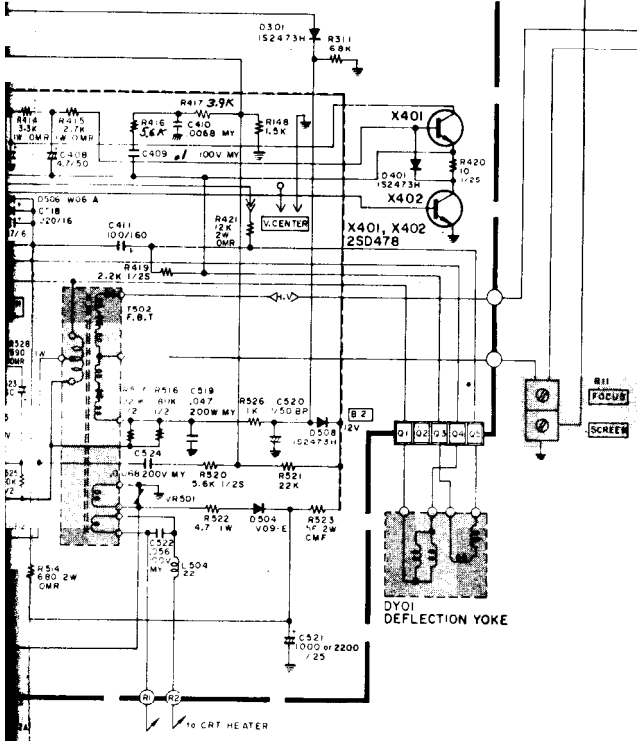
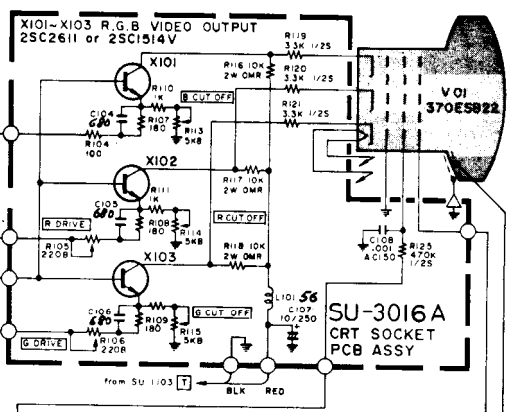
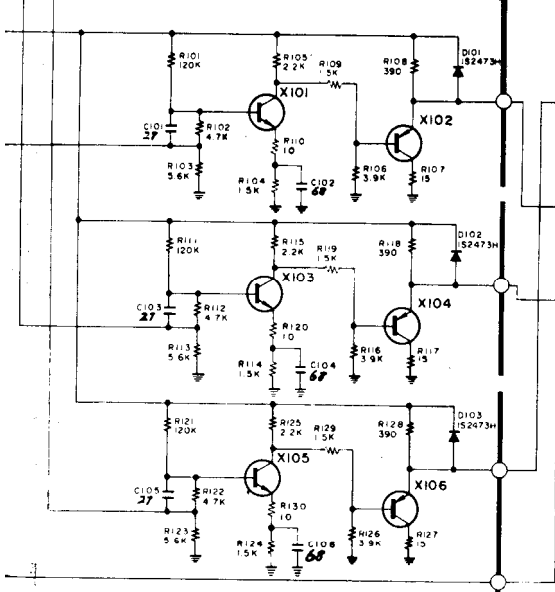

Schematic Notes

- Unless otherwise specified
- Resistance: (Ω) (K \rightarrow K Ω , M \rightarrow M Ω), 1/4 (W) carbon resistor
- Capacitance: 1 or higher \rightarrow (pF), less than 1 \rightarrow (μ F) working voltage \rightarrow 50 (V) ceramic capacitor
- Inductance: (μ H)
- Electrolytic Cap: Capacitance Value (μ F)/working voltage (V), NP \rightarrow non-polar (or bipolar) electrolytic cap.
- Refer to the parts list for additional component information.
- \odot indicates test point connection
- \perp indicates chassis ground unless otherwise specified
- Hz indicates cycles per second
- For **safety** purposes (and continuing reliability) \triangle replace all components marked with safety symbol with identical type.
- NOTE: FR \rightarrow fusible resistor ($\text{---} \text{---} \text{---}$)

G07-FBO
 00-4147-03

Parts identification on circuit boards:
 e.g. SU1126A (R107 = R1107)
 SU3030A (R113 = R3113)

REPLACEMENT PARTS LIST - ELECTROHOME 13" MONITOR

Components identified by the Δ symbol in the PARTS LIST and on the Schematic have special characteristics important to safety.

DO NOT degrade the safety of the set through improper servicing.

Abbreviations for Resistors and Capacitors

Resistor

C R	: Carbon Resistor
Comp. R	: Composition Resistor
OM R	: Oxide Metal Film Resistor
V R	: Variable Resistor
MF R	: Metal Film Resistor
CMF R	: Coating Metal Film Resistor
UNF R	: Nonflammable Resistor
F R	: Fusible Resistor

Capacitor

C Cap.	: Ceramic Capacitor
M Cap	: Mylar Capacitor
E Cap.	: Electrolytic Capacitor
BP E Cap.	: Bi-Polar (or Non-Polar) Electrolytic Capacitor
MM Cap.	: Metalized Mylar Capacitor
PP Cap.	: Polypropylene Capacitor
MPP Cap.	: Metalized PP Capacitor
PS Cap	: Polystyrol Capacitor
Tan. Cap.	: Tantal Capacitor

NOTE: When ordering replacement parts please specify the part number as shown in this list including part name, and model number. Complete information will help expedite the order.

Use of substitute replacement parts which do not have the same safety characteristics as specified, may create shock, fire or other hazards. For maximum reliability and performance, all parts should be replaced by those having identical specifications.

Symbol	Description	Part Number
	Main P.C.B. Ass'y	SU-1103A
	CRT Socket P.C.B. Ass'y	SU-3016A
Outside of the P.C.B. Ass'y		
Symbol	Description	Part Number
Δ V01	Δ Picture Tube	370ESB22(E)
Δ DY01	Δ Deflection Yoke	C29123-V
	PC Magnet	A76366-A
	Wedge	C30006
	Δ Flyback Transf.	A19183-A
Δ R11	Δ Focus V R	A46606-A
Δ R05	UNF Resistor 220 Ω , 25W. K	QRF258K-221
Δ C04	Δ C Capacitor 150 pF, AC1.5KV	QCZ0101-005
X01	Si. Transistor	2SD869
IC01	IC Regulator	STR383
L01	Degaussing Coil	21-1007-31
	Degaussing Coil Pin Terminal (2)	34-708-01
	Degaussing Coil Pin Terminal Housing	34-709-01
	Groundstrap Ass'y.	34-697-04
	Groundstrap Wire Terminal	34-228-03
	Groundstrap Spring (2)	35-3560-01
BR	Support Bracket RH	35-3919-01
BR	Support Bracket LH	35-3919-02
SC	SCREW 10- $\frac{1}{2}$ Pix Tube Mtg. (4)	31-631018-08
WA	Pyramidal Lockwasher (4)	33-255-01
	Clip P.C.B. Support (2)	33-629-02
	Ground Lug	34-33-04
CH	Chassis Base	38-452-01

Main P.C.B. Ass'y (SU-1103A) Parts List

Resistors

Symbol	Description	Part Number
R1406	V R 200Ω	QVZ3230-022
R1408	V R 200Ω	QVZ3230-022
R1410	CMF R 6.8Ω1W J	QRX019J-6R8
R1414	OM R 3.3KΩ1W J	QRG019J-332
R1415	OM R 2.7KΩ1W J	QRG019J-272
R1421	OM R 12KΩ2W J	QRG029J-123
R1422	V R 10KΩ	QVZ3224-014H
△FR1401	△F R 68Ω2W K	QRH024K-680M
△R1503	△CMF R 11.8KΩ¼W +1%	QRV142F-1182
R1504	V R 5KΩ	QVZ3230-053
R1509	OM R 10KΩ2W J	QRG029J-103
R1511	OM R 5.6KΩ2W J	QRG029J-562
R1514	OM R 680Ω2W J	QRG029J-681
R1515	CMF R 8.2Ω1W J	QRX019J-8R2
R1522	CMF R 4.7Ω1W J	QRX019J-4R7
R1523	OM R 56Ω2W J	ORG029J-560
R1528	OM R 390Ω1W J	ORG019J-391
R1534	ZN R	ERZ-C05ZK471
VR1501	ZN R	ERZ-C05DK271
△R1703	△CMF R 39KΩ½W +1%	QRV122F-3902
△R1704	△CMF R 7.68KΩ¼W +1%	QRV142F-7681
△R1901	△Posistor	A75414
R1902	UNF R 2Ω7W K	QRF076K-2R0
R1903	CMF R 5.6Ω3W J	QRX039J-5R6
R1904	OM R 10KΩ2W J	QRG026J-103Z
△FR1901	△F R 220Ω½W K	QRH124K-221M

Capacitors

Symbol	Description	Part Number
C1402	Tan. Cap. 2.2uF 16V K	QEE51CK-225B
C1411	E Cap. 100uF 160V A	QEW52CA-107
C1412	E Cap. 3.3uF 160V A	QEW52CA-335
C1508	PP Cap. 5600pF 50V J	QFP31HJ-562
C1511	E Cap. 47uF 160V A	QEW52CA-476S
△C1512	△PP Cap. 2000pF DC1500V J	QFZ0082-202
△C1513	△PP Cap. 2000pF DC1500V J	QFZ0082-202
△C1514	△PP Cap. 2500pF DC1500V J	QFZ0082-252
C1515	PP Cap. 0.53uF DC1200V K	QFZ0067-534
C1520	BPE Cap. 1uF 50V A	QEN61HA-105Z
C1524	M Cap. 0.1uF 200V K	QFM72DK-682M
C1904	E Cap.	QEY0034-001
C1905	E Cap. 10uF 250V A	QEW52EA-106
△C1907	△MM Cap. 0.1uF AC150V Z	QFZ9008-104

Coils

Symbol	Description	Part Number
L1501	Peaking Coil	A75360-6
L1502	Linearty Coil	A39934
L1503	Width Coil	C30380-A
L1504	Heater Choke	C30333-A
L1901	Line Filter	A39475-J

Transformers

Symbol	Description	Part Number
T1501	Hor. Drive Transf.	A46022-BM
T1503	Side Pin Transf.	C39050-A

Semiconductors			Part Number
Symbol	Description		
IC1501	I.C.		HA11244
X1101	Si. Transistor		2SC1685(R)
X1102	Si. Transistor		2SA673(C)
X1103	Si. Transistor		2SC1685(R)
X1104	Si. Transistor		2SA673(C)
X1105	Si. Transistor		2SC1685(R)
X1106	Si. Transistor		2SA673(C)
X1301	Si. Transistor		2SC1685(R)
X1302	Si. Transistor		2SC1685(R)
X1303	Si. Transistor		2SA673(C)
X1304	Si. Transistor		2SC1685(R)
X1305	Si. Transistor		2SC1685(R)
X1401	Si. Transistor		2SD478
X1402	Si. Transistor		2SD478
X1501	Si. Transistor		2SC2610BK
X1701	Si. Transistor		2SC1685(P-S)
D1101	Si. Diode		W06A
D1102	Si. Diode		W06A
D1103	Si. Diode		W06A
D1301	Si. Diode		1S2473H
D1401	Si. Diode		1S2473H
D1402	Zener Diode		RD10F(C)
D1503	Si. Diode		HF-1
D1504	Si. Diode		V09E
D1505	Zener Diode		RD11E(B)
D1506	Si. Diode		W06A
D1507	Si. Diode		1SS81
D1508	Si. Diode		1S2473H
△D1701	△Zener Diode		RD20EV2
△D1901	△Si. Diode		1S1887A
△D1902	△Si. Diode		1S1887A
△D1903	△Si. Diode		1S1887A
△D1904	△Si. Diode		1S1887A
Miscellaneous			Part Number
Symbol	Description		
△F1901	△Fuse 1A		QMF53U1-1R0S
△F1902	△UL Fuse 3A		QMF66U1-3R0S

CRT Socket P.C.B. Ass'y (SU-3016A) Parts List

Resistors

Symbol	Description	Part Number
R3105	V R 200Ω	QVZ3234-022
R3106	V R 200Ω	QVZ3234-022
R3113	V R 5KΩ	QVZ3234-053
R3114	V R 5KΩ	QVZ3234-053
R3115	V R 5KΩ	QVZ3234-053
R3116	OM R 10KΩ2W J	QRG029J-103
R3117	OM R 10KΩ2W J	QRG029J-103
R3118	OM R 10KΩ2W J	QRG029J-103
R3119	Comp. R 3.3KΩ½W K	QRZ0039-332
R3120	Comp. R 3.3KΩ½W K	QRZ0039-332
R3121	Comp. R 3.3KΩ½W K	QRZ0039-332

Capacitors

Symbol	Description	Part Number
C3107	E Cap. 10uF 250V A	QEW52EA-106
C3108	C Cap. 1000pF DC1400V P	QCZ9001-102M

Coils

Symbol	Description	Part Number
L3101	Peaking coil	QQL043K-101

Semiconductors

Symbol	Description	Part Number
X3101	Si. Transistor	2SC2611
X3102	Si. Transistor	2SC2611
X3103	Si. Transistor	2SC2611

Miscellaneous

Symbol	Description	Part Number
△	△ CRT Socket	A75522

VII. Coin Door Maintenance

SPECIAL NOTE: If you have any questions about the coin acceptors in your game(s), please feel free to contact their manufacturers. Each manufacturer's name is **PROMINENTLY** imprinted on every acceptor mechanism.

Metal mechanisms only:
COIN MECHANISMS, INC.
817 Industrial Drive
Elmhurst, IL 60126
Phone (312) 279-9150

Metal and Plastic mechanisms:
COINCO COIN ACCEPTORS, INC.
860 Eagle Drive
Bensenville, IL 60106
Phone (312) 766-6781

COIN DOOR MAINTENANCE

METAL COIN ACCEPTOR MECHANISMS

Periodically, the metal coin acceptor mechanism(s) must be removed from the coin door and cleaned.

1. **Make sure the power to the game is off.**
2. Unlock and open the coin door.

3. Remove the coin acceptor mechanism as shown in Figure 7-1.

- Push down on the two spring loaded latches.
- While holding the latches down, pull the top of the coin acceptor mechanism toward you.
- Release the latches and lift out the coin acceptor mechanism.

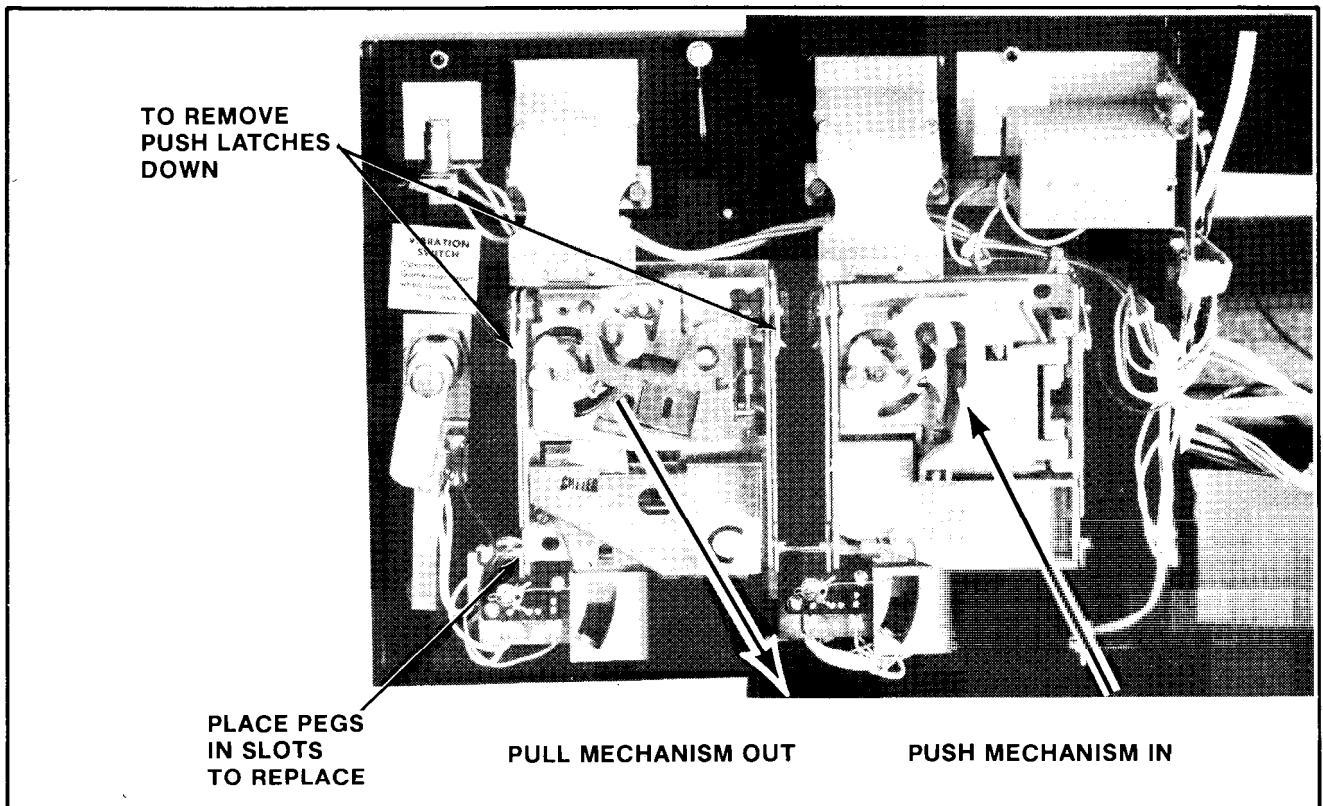

Figure 7-1 Removing and replacing coin acceptor

4. Clean the magnet of all foreign particles. See Figure 7-2.
 - This may be accomplished by swinging the gate open as shown in the above figure.
5. Remove the cradles and undersize levers and clean the bushings. (A pipe cleaner makes a good bushing cleaner.)
 - Also clean the pivot pin.
6. Whenever needed, the coin acceptor should be cleaned with hot water and cleanser in the following manner:
 - Place the coin acceptor in boiling water for about ten minutes.

CAUTION: BE CAREFUL NOT TO BURN YOURSELF.

- Next, use a brush and kitchen cleaner to remove all remaining foreign matter from the unit.
- Rinse the coin acceptor in clean boiling water.
- Dry the coin acceptor thoroughly by using filtered compressed air to blow it dry.

NOTE: The reason we recommend using boiling water is that it evaporates faster than cold water and speeds drying time.

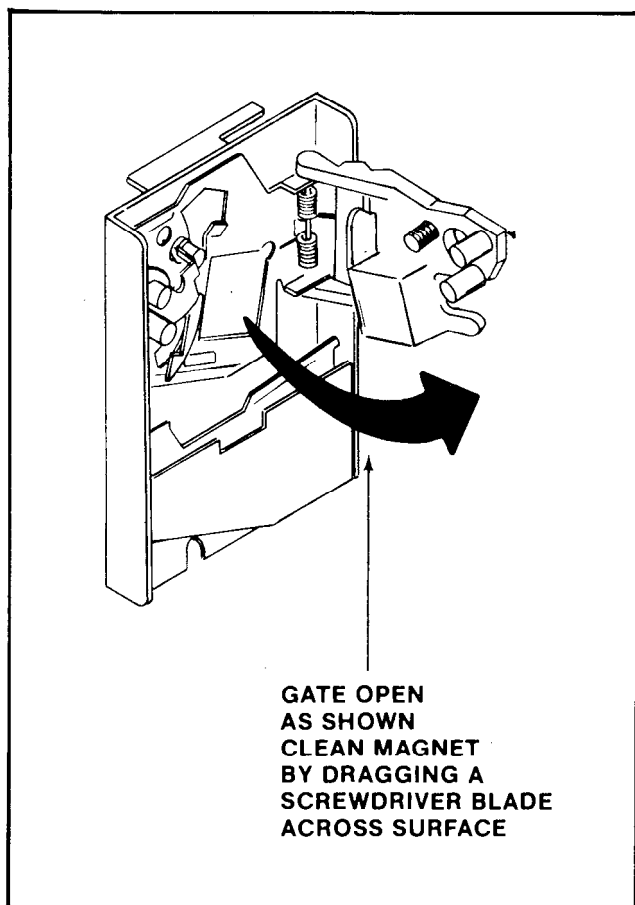

Figure 7-2 Cleaning the metal coin acceptor

7. To lubricate the coin acceptor:
 - Use **ONLY** powdered graphite and put it **ONLY** on the moving parts of the coin acceptor. These parts are called out in Figure 7-3.
 - Be extremely careful to keep the powdered graphite away from paths that are traveled by the coins.

— WARNING —
**DO NOT USE OIL
TO LUBRICATE THE
COIN ACCEPTOR.**

8. Check the coin chute for obstructions such as: paper, gum, etc.
9. Reinstall the coin acceptor to the coin door. See Figure 7-1.
 - Place the two pegs at the coin acceptor's base into their retaining slots.
 - Now push the top of the coin acceptor toward the coin door until it snaps in place and is held there by the two spring loaded latches
10. Close and lock the coin door

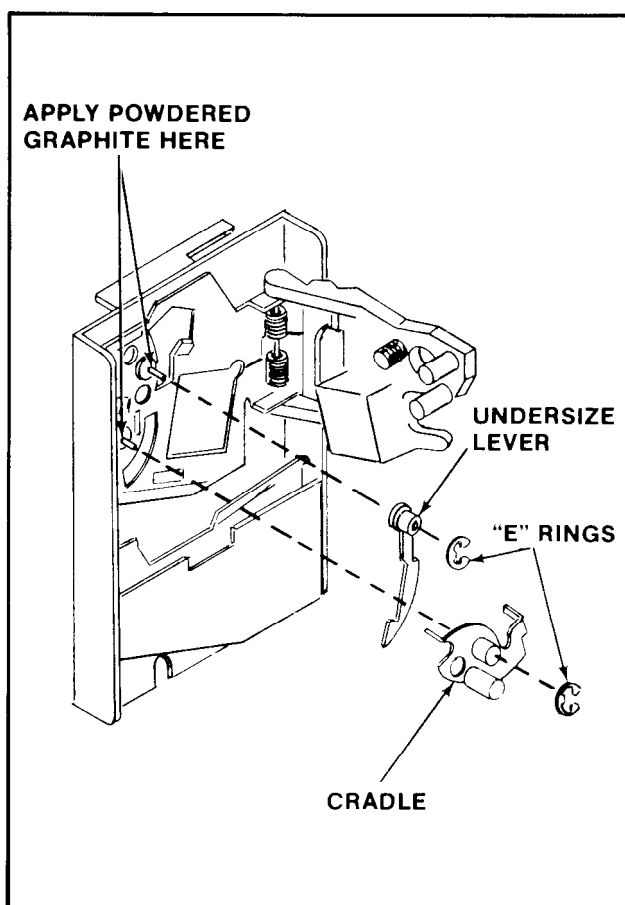

Figure 7-3 Lubricating the metal coin acceptor

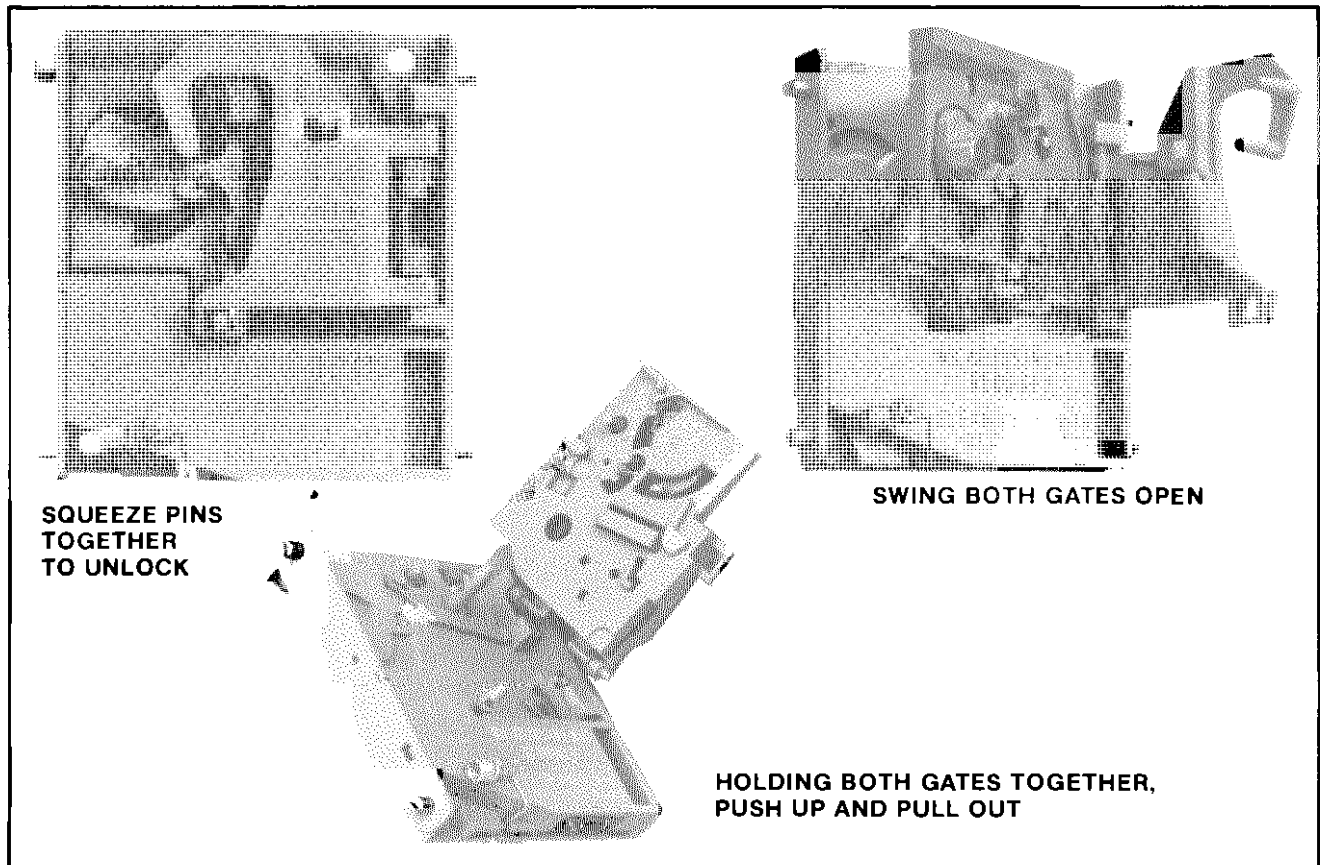

Figure 7-4 Opening the plastic coin acceptor

PLASTIC COIN ACCEPTOR MECHANISMS

The plastic coin acceptor mechanism(s) must be removed periodically from the coin door and cleaned.

1. **Make sure the power to the game is off.**
2. Unlock and open the coin door.
3. Remove the coin acceptor mechanism(s) as shown in Figure 7-1.
 - Push down on the two spring loaded latches.
 - While holding the latches down, pull the top of the acceptor mechanism toward you.
 - Release the latches and lift out the mechanism.
4. Squeeze the two pins indicated in Figure 7-4 together to open the mechanism and break it down into its three basic parts.
 - Clean the mechanism in hot soapy water. It never rusts.
 - Rinse the mechanism in clean hot water and allow it to dry.

- Reassemble the mechanism (it never needs lubrication).

5. Check the coin chute for obstructions such as: paper, gum, etc.
6. Reinstall the coin acceptor to the coin door. See Figure 7-5.
 - Place the two pegs at the coin acceptor's base into their retaining slots.
 - Now push the top of the coin acceptor toward the coin door until it snaps in place and is held there by the two spring loaded latches.
7. Close and lock the coin door.

NOTE: See Figure 7-6 for instructions on how to set the plastic coin acceptor mechanisms to either accept or reject Canadian quarters.

ACCEPTOR CAN BE SET TO ACCEPT U.S. QUARTERS ONLY OR BOTH U.S. AND CANADIAN QUARTERS.

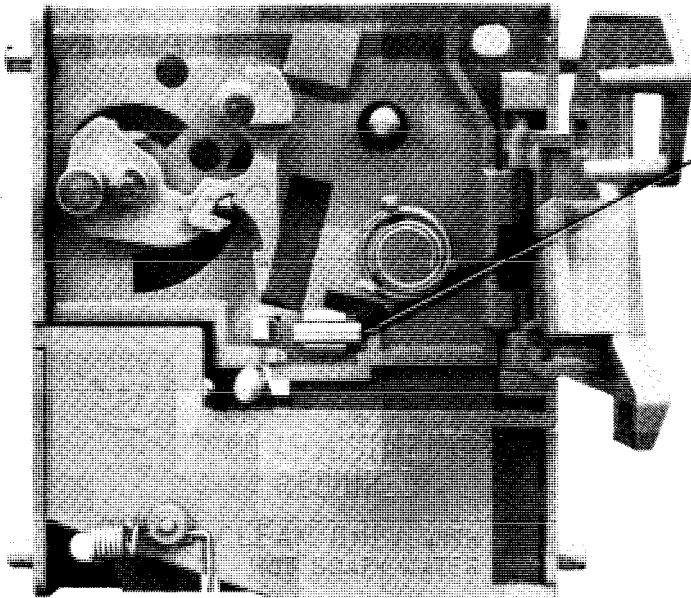

MAGNET



SLIDE MAGNET TO EXTREME RIGHT (AS SHOWN) TO ACCEPT BOTH U.S. AND CANADIAN QUARTERS.

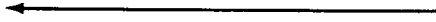

TO ACCEPT U.S. QUARTERS ONLY, SLIDE MAGNET TO EXTREME LEFT.

Figure 7-5 Changing the plastic coin acceptor to accept American or Canadian quarters.

DESIGNATION LIST

<u>DESIGNATION</u>	<u>DESCRIPTION</u>
C1,C2	4.7mf 25v rd.tant.
C3,C4	22mf 6v " "
C5,C6	470mf 6v ax.elect.
C7-C10	.1mf 50v ax.cr.
CP1	220mf 25v ax.elect.
CP2,CP3	.1mf 50v ax.cr.
R1,R2	2.7K Ω 1/4w 5% CRBN.
R3,R4	27 Ω " " "
R5-R8	1 Ω 1/2w " "
U1,U2	MB3730
J1	3 PIN STRT. KK156
J2	3 " " "
HSA1,2	HEATSINK ASSY.
MH1-MH4	HEYCO BUSHING

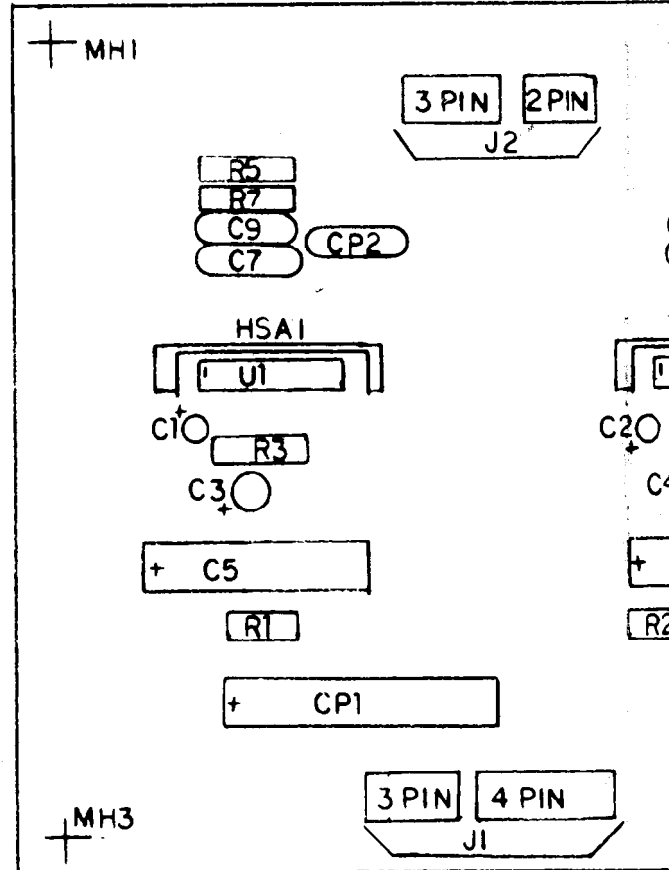

PROJECT ENG. C.MEDNICI

DIM. TOLERANCES UNLESS OTHERWISE SPEC		FIRST USED ON	TRON
CONCENTRICITY T I R	.002	DRN	TJK
FRACTIONAL	$\pm 1/64$	MECH CHK	MAT L
DECIMAL	$\pm .005$	ELEC CHK	FINISH
HOLE DIA	+ .002 - .000	(C. J. J.)	
ANGLE	$\pm 1/2^\circ$	DO NOT SCALE DWG	

CROSS REFERENCE LIST

<u>DESCRIPTION</u>	<u>QTY</u>	<u>DESIGNATION</u>	<u>PART NO.</u>
.1mf 50v ax.cr.	6	C7-C10, CP2,CP3	0986-008001100
4.7mf 25v rd.tant	2	C1,C2	0986-008003100
22mf 6v " "	2	C3,C4	0986-008001600
220mf 25v ax.&lec	1	CPI	0986-008003200
470mf 6v " "	2	C5,C6	0986-008001700
1Ω 1/2w 5%	4	R5-R8	0062-026D3-1XXX
27Ω 1/4w " "	2	R3,R4	0062-068B3-1XXX
2.7K " "	2	R1,R2	0062-199B3-1XXX
MB3730	2	U1,U2	0066-188XX-XX4X
2 PIN STRT, KKI56	1	J2	3000-16367-0200
3 " " " "	2	J1,J2	3000-16367-0300
4 " " " "	1	J1	3000-16367-0400
HEATSINK ASSY.	2	HSA1, HSA2	A986-00010-E000
HEYCO BUSHING	4	MHI-MH4	0017-00042-0014
PC BOARD	1		A080-90910-E000

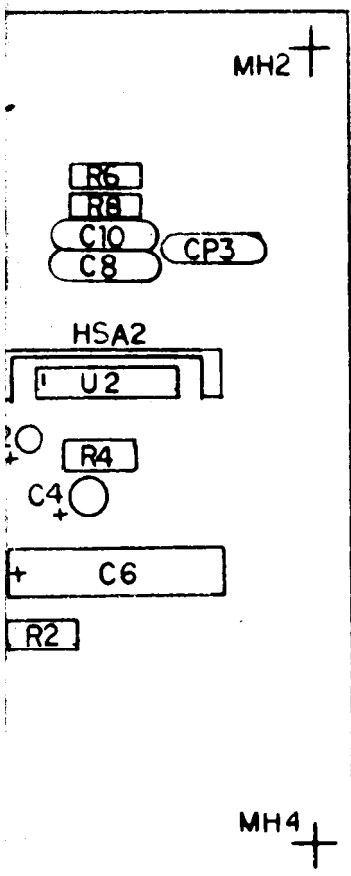

NICK		THIS DWG IS CONFIDENTIAL & PROPERTY OF MIDWAY MFG CO			
ON		MIDWAY MFG. CO. FRANKLIN PK., IL. 60131 A BALLY CO			
DATE	SCALE				
9-1-82	FULL	DUAL PWR. AMP. ASSY A080-90910-E000		REVISIONS	
				PART NO	

MT 89 DOMESTIC
MT 90 EXPORT

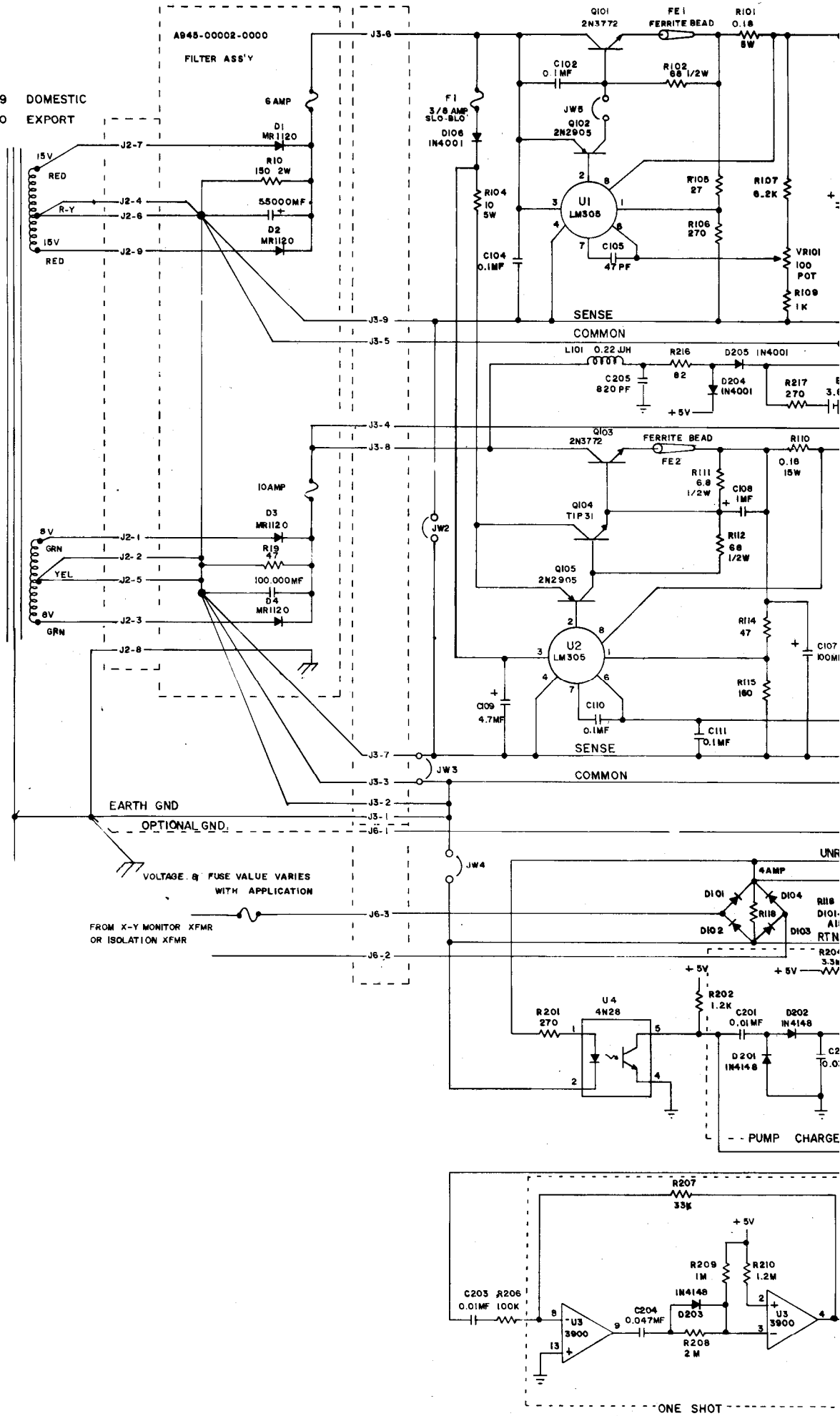

VOLTAGE & FUSE VALUE VARIES WITH APPLICATION

FROM X-Y MONITOR XFMR OR ISOLATION XFMR

ONE SHOT

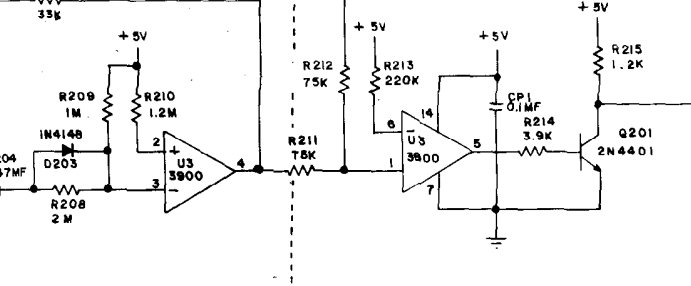
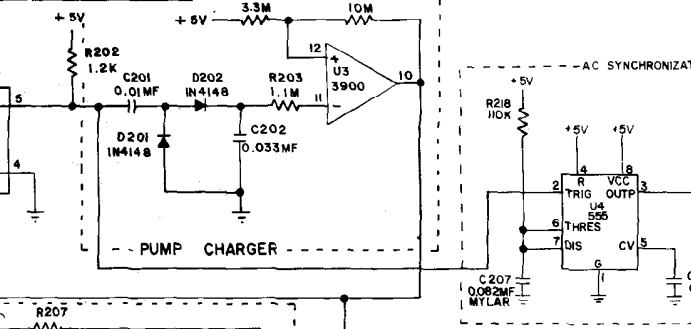
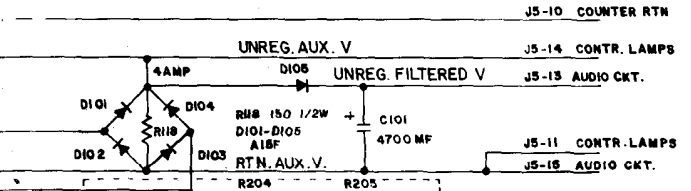
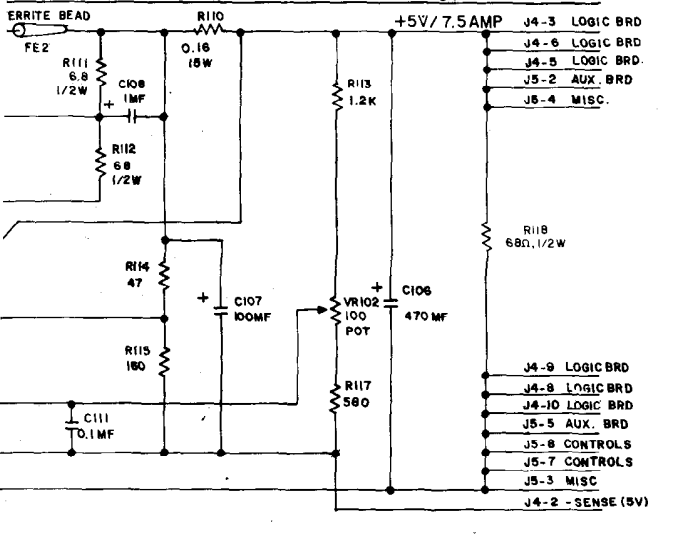
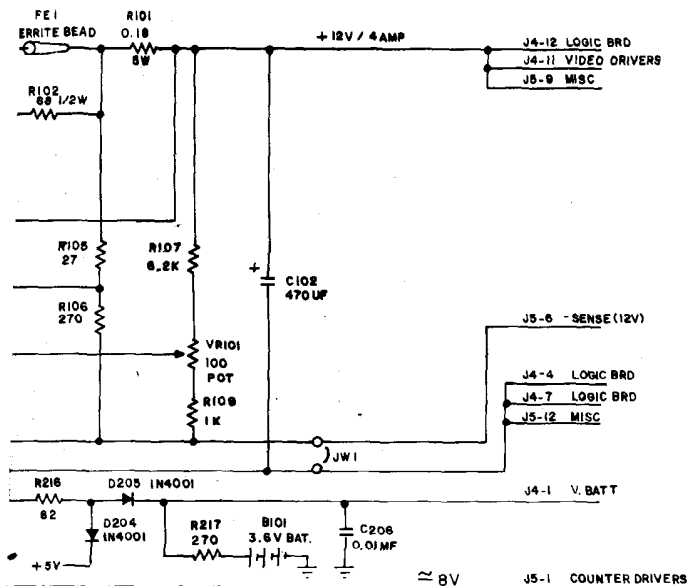

PROJECT ENG: L. DEKKER		DESIGNED BY: SATANS HOLLOW		MIDWAY MFG. CO.	
DO NOT SCALE DWG		SCALE: FULL		FRANKLIN PA. U.S.A.	
DIM TOLERANCES UNLESS SPECIFIED		NO. REVISIONS: 1 PER.		PART NO.	
DATE: 5/3/82		POWER SUPPLY (25VA W/CKT SUPPORT A082-90412-0000		M051-00945-D007	

ONE SHOT

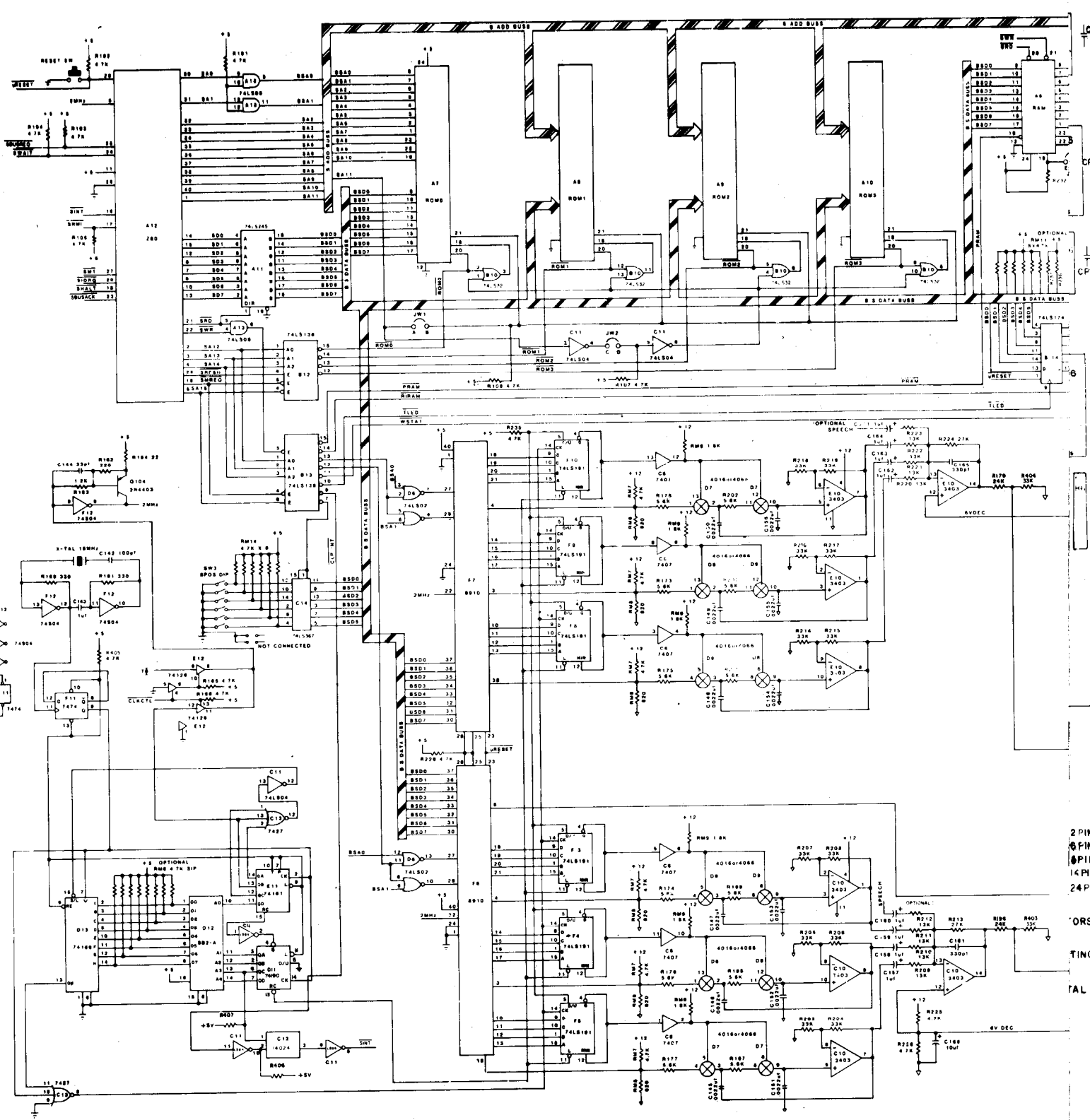

2 PIN
 6 PIN
 14 PIN
 24 PIN
 ORS
 TING
 TAL

S
 A
 A

CROSS REFERENCE LIST

DESCRIPTION	QTY.	DESIGNATION	PART NOS.
33PF 50V AX. CER.	1	C101	0986-00800-0300
390PF 50V AX. CER.	2	C104, C200	0986-00800-3000
0.01UF 50V AX. CER.	78	CP2-CP7, CP9-CP14, CP16-CP20, CP22-CP28, CP30-CP37, CP39-CP50, CP52-CP57, CP59-CP64, C115-C136	0986-00800-2200
0.1MF 100V MYLAR	1	C103	0986-00800-0100
0.1MF 50V AX. CER.	2	C102-CP66	0986-00800-0200
10MF 25V AX. TANT	5	CP8, CP21, CP29, CP38 CP51	0986-00800-3400
470UF 16V AX. ELECT.	4	CP1, CP15, CP58, CP65	0986-00800-3300
#C105-C114	SEE NOTE		
10 OHM 1/4W CRBN.	6	R126, R127, R133, R134, R140, R141	0062-05183-1XXXX
22 OHM "	1	R106	0062-06383-1XXXX
100 OHM "	1	R119	0062-11083-1XXXX
220 OHM "	1	R105	0062-13383-1XXXX
330 OHM "	2	R108, R111	0062-14483-1XXXX
470 OHM "	3	R121, R128, R135	0062-15683-1XXXX
510 OHM "	3	R123, R130, R138	0062-15983-1XXXX
560 OHM "	2	RH7, R118	0062-16283-1XXXX
820 OHM "	1	R120	0062-17483-1XXXX
1K OHM "	13	R102, R107, R109, R116, R124, R129, R137, R201, R203-R207	0062-17983-1XXXX
1.2K OHM "	1	R104	0062-18383-1XXXX
2K OHM "	3	R125, R131, R138	0062-19383-1XXXX
4.7K OHM "	4	R101, R12, R208, R209	0062-21183-1XXXX
4.7K 6PIN S.I.P.	2	RM1, RM4	0986-00804-2400
4.7K 10PIN S.I.P.	2	RM2, RM3	0986-00804-4600
1N5817	1	D101	0986-00801-0300
4148	1	D102	0986-00801-0100
2N4403	1	Q101	0986-00802-0200
2N4123	1	Q102	0986-00802-0100
MPSA70	6	Q103-Q108	0986-00802-0300
74LS04	3	A11, B9, C10	0986-00803-0400
74LS04	2	D8, E9	0986-00803-1007
74LS08	1	C8	0986-00803-1006
74LS20	2	C11, C12	0986-00803-1004
74LS27	1	E8	0986-00803-9500
74LS32	4	B8, B11, E4, E5	0986-00803-0600
74S74	2	A9, A10	0986-00803-1500
74LS74	2	B10, C9	0986-00803-1005
74LS86	2	E7, G7	0986-00803-9900
74LS133	1	B7	0986-00803-1002
74LS138	1	E6	0986-00803-1900
74LS153	2	G1, G6	0986-00803-1000
74LS157	7	D10, D11, D12, F8, F9, G9, G10	0986-00803-9700
74LS161	1	A1	0986-00803-1003
74LS174	2	F7, G8	0986-00803-9800
74LS244	2	B1, B6	0986-00803-0800
74LS245	2	A3, F3	0986-00803-0900
74LS273	4	F4, F5, G2, G5	0986-00803-1001
74LS307	1	A2	0986-00803-2200
MK3380	1	B5	0986-00803-7800
MK3382	1	B3	0986-00803-7700
4017	1	F2	0986-00803-8700
4053	1	F1	0986-00803-2000
CMOS RAM	1	B2	0986-00803-8100
6116	1	F6	0986-00803-1008
93419	1	F10	0986-00803-9600
H-T GEN.	1	A12	0986-00803-8900
V-T GEN.	1	G12	0986-00803-9000
V-E-H GEN.	1	B12	0986-00803-9100
MISC CUSTOM	1	G11	0986-00803-9200
NVR CONTROLLER	1	E3	0986-00804-3200
EPROM	1	D2	ROW/EPROM OPT-IONS KIT 0628-00803-0100
EPROM	1	D3	
EPROM	1	D4	
EPROM	1	D5	
EPROM	1	D6	
EPROM	1	D7	
EPROM	1	G3	
EPROM	1	G4	
*SEE NOTE	5	L101-L105	
10UH WW	5	L106-L110	
10UH MOLDED	6	L111-L116	0986-00804-3300
8 PIN IC SOCKET	2	ICSA12, ICSG12	0986-00804-3600
16 PIN "	2	ICSA12A, ICSG12A	0986-00804-3700
20 PIN "	3	ICSB12, ICSE3, ICSG11	0986-00804-3800
24 PIN "	2	ICSB2, ICSF6	0986-00804-3400
28 PIN "	10	ICSB3, ICSD2, ICSD3, ICSD4, ICSD5, ICSD6, ICSD7, ICSF10, ICSG3, ICSG4,	0986-00804-3900
40 PIN "	1	ICSB5	0986-00804-3500

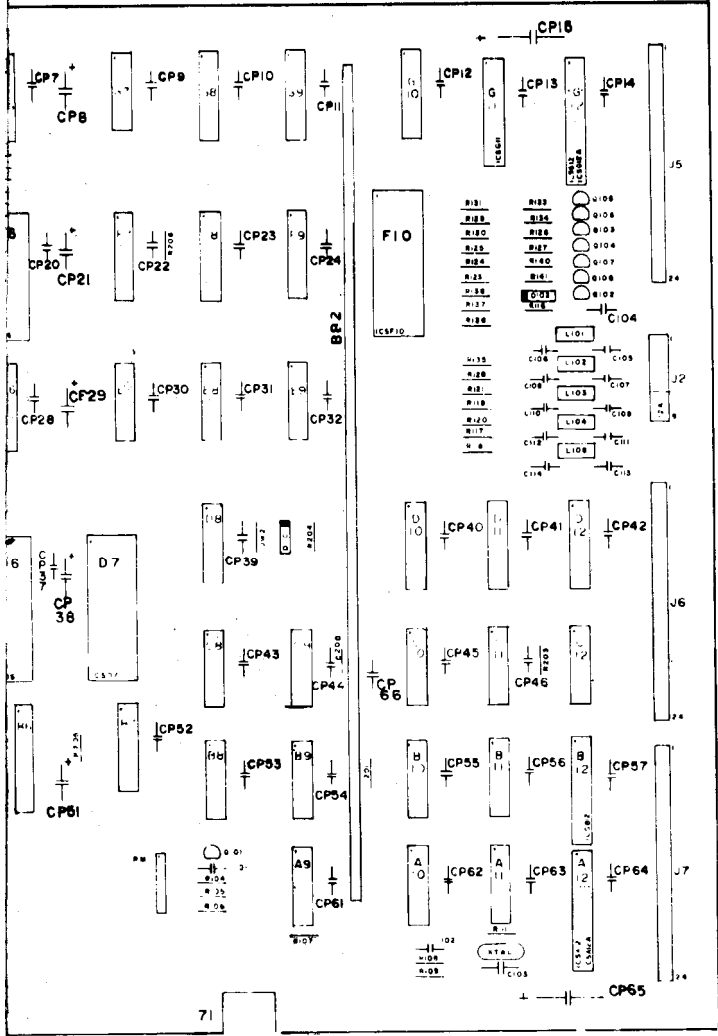

QTY.	DESIGNATION	PART NOS.
2 PIN CONN.	J2A	0986-00804-4200
6 PIN CONN.	J2	0986-00804-4300
5 PIN CONN.	J1A	0986-00804-4400
14 PIN CONN.	J1	0986-00804-4500
24 PIN CONN.	J3, J4, J5, J6, J7	0986-00804-4700
40S	JW1-JW19	0986-00804-4000
ITING	SW1	0986-00804-3100
TAL	XTAL	0986-00804-4900
2	BB1, BB2	0986-00804-4100
5	J3, J4, J5, J6, J7	0986-00804-4800

MIDWAY MFG. CO.
 SUPER CPU BOARD
 ASSEMBLY DRWG.
 A084-90010-A941
 M051-00941 - A015

DESIGNATION LIST

DESIGNATION	DESCRIPTION	DESIGNATION	DESCRIPTION
CI, 2	100 μF AX. ELECT	IC H 1	74 LS 86
CI01	100 pF AX. CER.	IC H 2	74174
		IC H 3	74 S 74
CPI-3, 5-10		IC H 4	74175
CP12-20,22-27,		IC H 5	74174
CP29-33,35,36,		IC H 6	74 LS157
CP38-41,43-47, .01μf AX. CER.		IC J 2	74 LS 30
CP49-54,56-61,		IC J 3	7430
CP63-67,69-71.		IC J 4	74 LS273
		IC J 5	422
		IC J 6	74 LS157
		IC K 1	74161
		IC K 2	7430
		IC K 3	7474
		IC K 4	74161
		IC K 5	422
		IC K 6	2114-2
		IC L 1	74 LS 20
		IC L 2	7408
		IC L 3	7474
		IC L 4	74 LS283
		IC L 5	422
		IC L 6	2114-2
		IC L 7	74 LS157
		IC M 1	7430
		IC M 2	7432
		IC M 3	74 S 74
		IC M 4	74161
		IC M 5	422
		IC M 7	74 LS157
		IC N 1	430
		IC N 2	7427
		IC N 3	74 LS273
		IC N 4	74 LS283
		IC N 5	74 LS 245
		IC N 6	7404
		IC N 7	74 LS157
		ICSA1,B1,C1,D1.	28PIN IC SOCKET
		ICSB5,6,C5,6,	22PIN IC SOCKET
		J5,K5,L5,M5.	
		ICSK6,L6.	18PIN IC SOCKET
		J3,4,5	24 PIN SOCKET
		JW1-8	JUMPER WIRE
		BB1, 2	BUSS BAR
IC A 1	EPROM		
IC A 2	74 LS157		
IC A 3	74 LS157		
IC A 4	74 LS157		
IC A 5	74 LS157		
IC A 6	74 LS157		
IC A 7	74 LS157		
IC B 1	EPROM		
IC B 2	74 LS194		
IC B 3	74 LS194		
IC B 4	74 LS32		
IC B 5	422		
IC B 6	422		
IC B 7	74 LS32		
IC C 1	EPROM		
IC C 2	74 LS194		
IC C 3	74 LS194		
IC C 4	74 LS 32		
IC C 5	422		
IC C 6	422		
IC C 7	74 LS 32		
IC D 1	EPROM		
IC D 2	74 LS194		
IC D 3	74 LS194		
IC D 4	74 LS273		
IC D 5	74 LS157		
IC D 6	74 LS157		
IC D 7	74 LS 273		
IC E 2	74 LS194		
IC E 3	74 LS194		
IC E 4	74 LS374		
IC E 5	74 LS157		
IC E 6	74 LS157		
IC F 2	7400		
IC F 3	74 S04		
IC F 4	74 LS 374		
IC F 5	74 LS157		
IC F 6	74 LS157		
IC G 1	74 LS 86		
IC G 2	74 LS 20		
IC G 3	74 LS283		
IC G 4	74 LS283		
IC G 5	74 LS283		

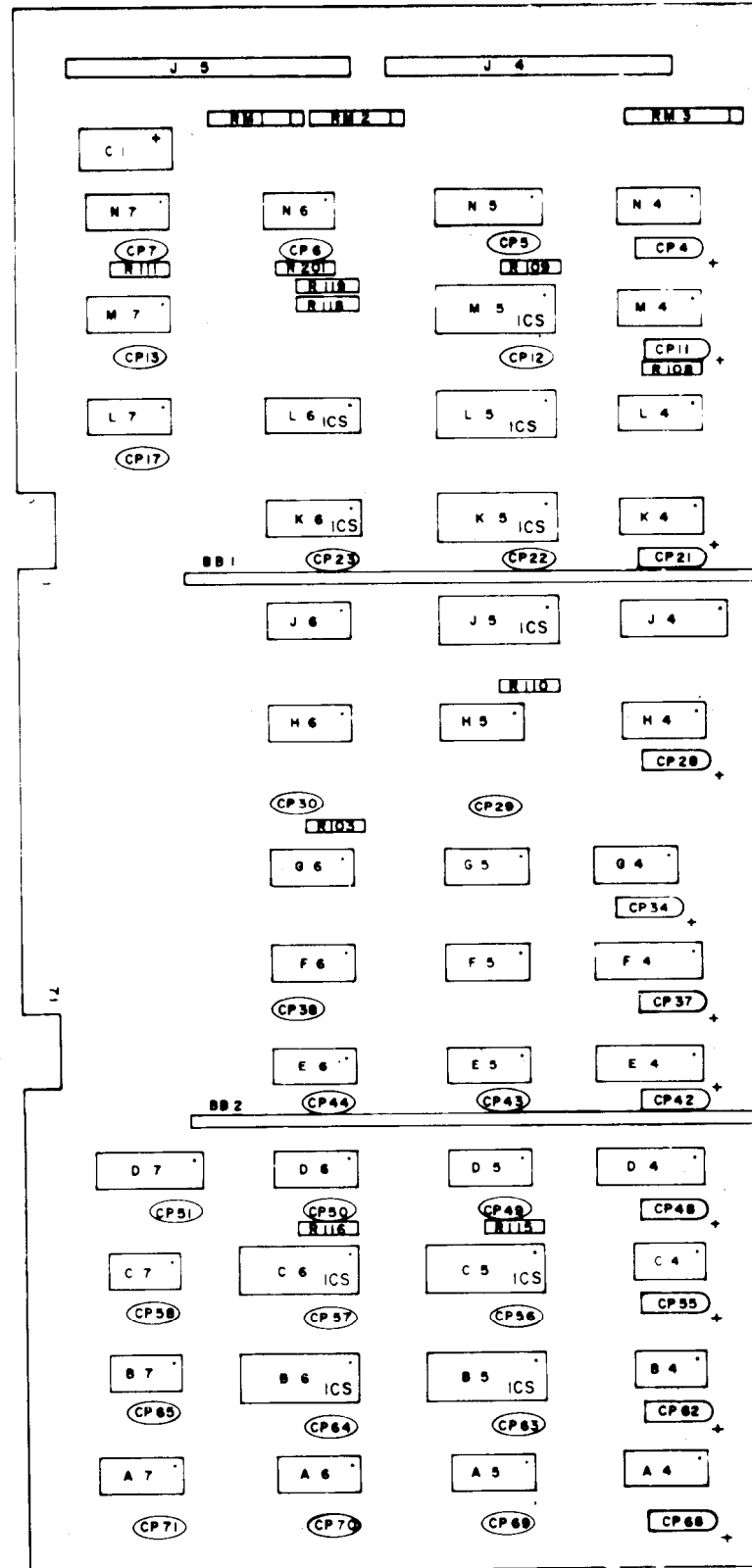

PROJ. ENG.

DO NOT SCALE
DIM TOLERANCES
UNLESS SPECIFIED

CROSS REFERENCE LIST

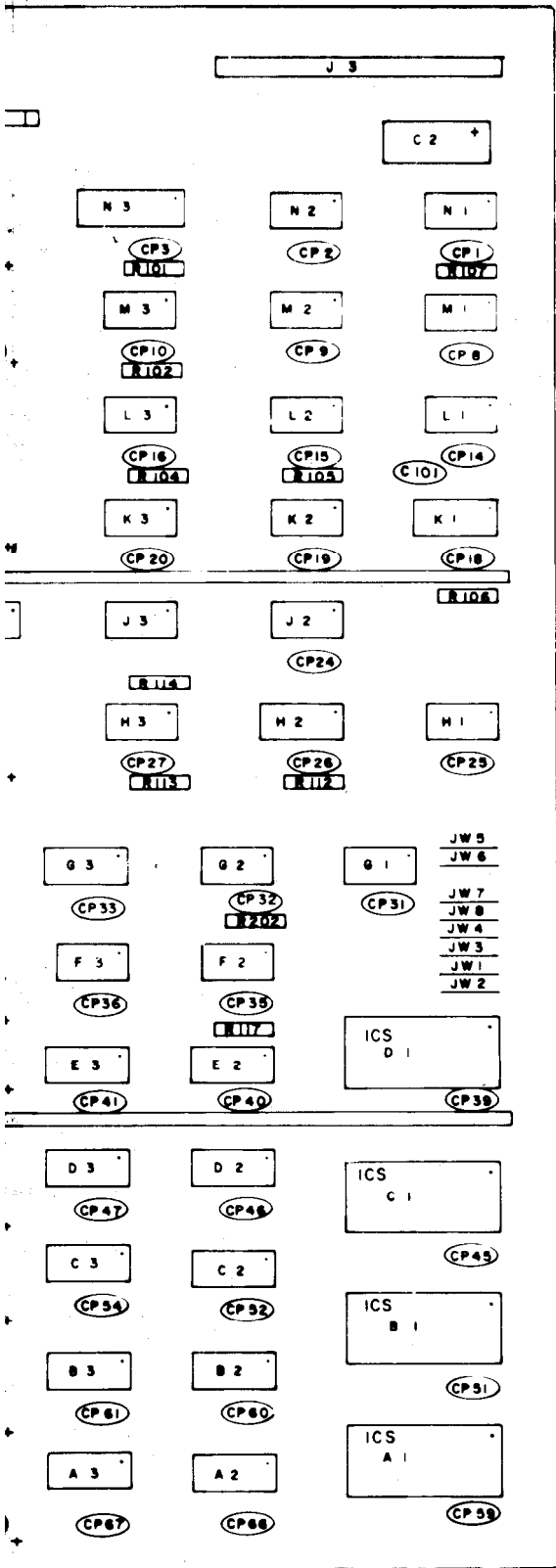

Q'TY	DESCRIPTION	DESIGNATION	PART NO.
60	100 P1 50V AX. CER. .01 μ f 50V AX. CER.	C101 CP1-3, CP5-10, CP12-20, CP22-27, CP29-33, CP35,36, CP38-41, CP43-47, CP49-54, CP56-61, CP63-67, CP69-71. CP4, 11, 21, 28, 34, 37, CP42, 48, 55, 62, 68. C1, 2.	0986-00800-1000 0986-00800-2500
11	10 μ f 25 V AX. TANT.	R101-119, 201, 202.	0986-00800-2400
2	100 μ f 25V AX. ELECT.	RM1, 2. RM3	0986-00800-1800
21	1 K 1/4 W CRBN. FLM.	K6, L6.	0062-17983-1XXX
2	1 K 8 PIN SIP	F2	0986-00804-1100
1	1 K 10 PIN SIP	N6	0986-00804-1000
2	2114 - 2	F3	0986-00803-2300
1	7400	N6	0986-00803-2800
1	7404	F3	0986-00803-8300
1	74S04	L2	0986-00803-3100
1	7408	G2, L1	0986-00803-3200
2	74LS20	N2	0986-00803-3400
1	7427	J3, K2, M1, N1	0986-00803-3500
4	7430	J2	0986-00803-3600
1	7432	M2	0986-00803-4300
4	74LS32	B4,7, C4,7,	0986-00803-4400
2	7474	K3, L3	0986-00803-3700
2	74S74	H3, M3	0986-00803-4500
2	74LS86	G1, H1	0986-00803-4100
18	74LS157	A2,3,4,5,6,7, D5,6, E5,6, F5,6, G6, H6, J6, L7, M7, N7.	0986-00803-4200 0986-00803-2400
3	74161	K1, K4, M4.	0986-00803-2500
2	74174	H2,5	0986-00803-2600
1	74175	H4	0986-00803-2700
8	74LS194	B2,3, C2,3, D2,3, E2,3.	0986-00803-2900
1	74LS245	N5	0986-00803-3000
4	74LS273	D4,7, J4, N3	0986-00803-3800
5	74LS283	G3,4,5 L4, N4,	0986-00803-3900
2	74LS374	E4, F4	0986-00803-4000
8	93422	B5,6, C5,6, J5, K5, L5, M5	0986-00804-0800
1	EPROM	A1 (VG A)	} ROM/EPROM OPTIONS KIT 0628-00803-3026
1	EPROM	B1 (VG B)	
1	EPROM	C1 (VG C)	
1	EPROM	D1 (VG D)	
8	JUMPER WIRE	JW1-8	0986-00805-0200
2	BUSS BAR	BB1.2	0986-00804-0900
1	P.C. BOARD		A080-91399-E000
3	24 PIN SOCKET	J3,4,5	0986-00804-4700
4	28 PIN SOCKET	ICSA1, B1, C1, D1	0986-00804-0300
8	22 PIN SOCKET	ICSB5,6, C5,6, J5, K5, L5, M5	0986-00804-0700
2	18 PIN SOCKET	ICS K6, L6	0986-00804-0600

IG. ATISH GHOSH

DESIGNER		DATE		REVISED	
CHECKED		APPROVED		REVISIONS	
SCALE		MATERIAL		FRANKLIN PER ILL	
DRAWN		NONE		MIDWAY MFG. CO.	
DATE		NO REQD I PER		PART NO	
9/ 1/82		ASS'Y DRAWING		M051-00941-A007	
		VIDEO GENERATOR P.C			
		A084-91399-A941			

- J1**
- PIN 1 ——— N.C.
 - 2 ——— L. AUDIO
 - 3 ——— L. SHIELD
 - 4 ——— KEY
 - 5 ——— V AUDIO RETURN
 - 6 ——— R. AUDIO
 - 7 ——— R. SHIELD
 - 8 ——— V AUDIO

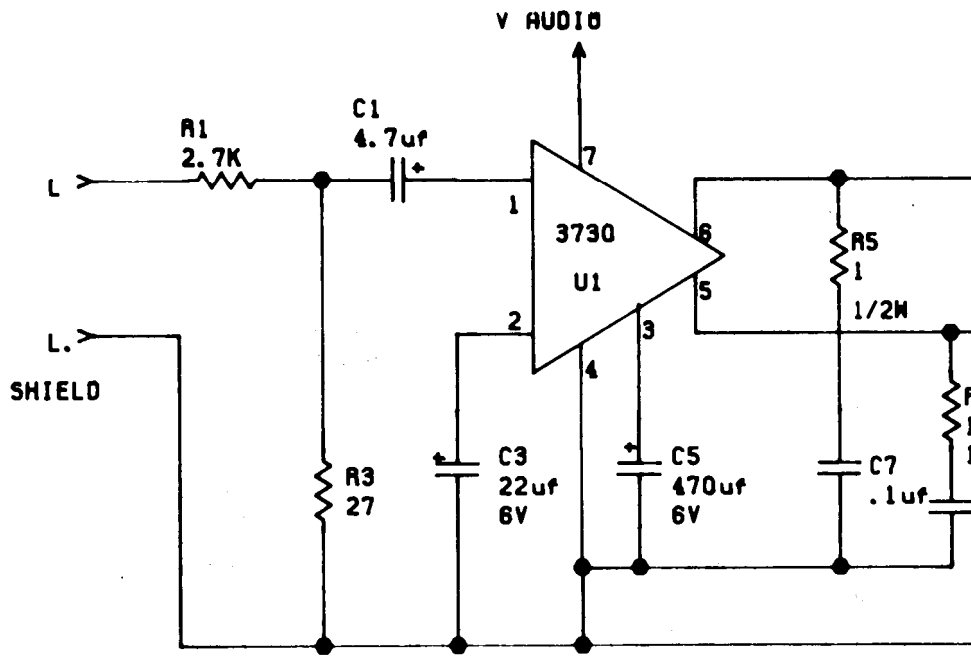

- J2**
- PIN 1 ——— R+
 - 2 ——— R-
 - 3 ——— KEY
 - 4 ——— L+
 - 5 ——— N.C.
 - 6 ——— L-

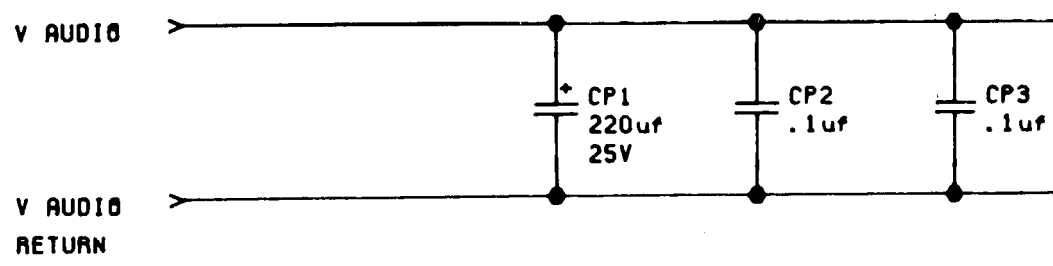
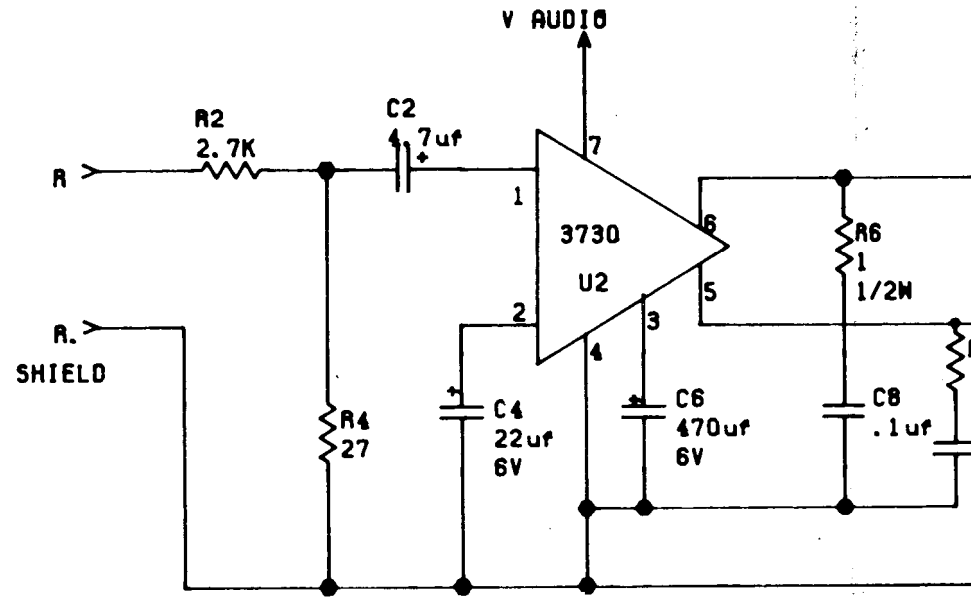

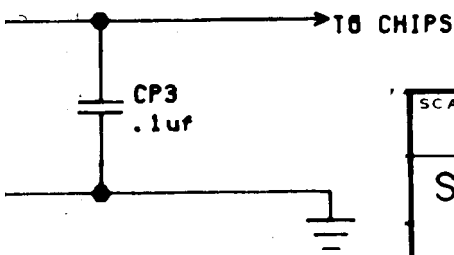
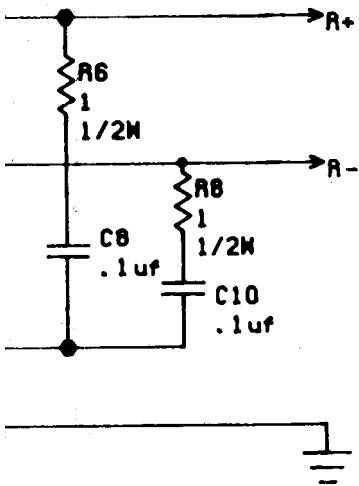
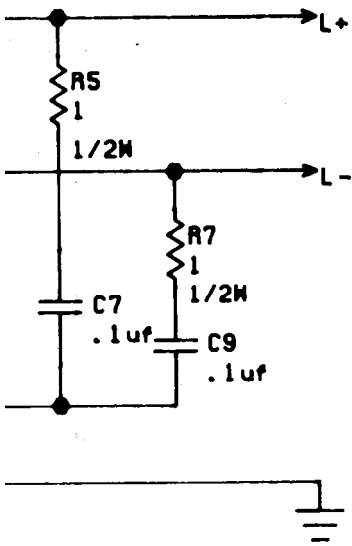

	USED ON TRON	MIDWAY MFG. CO. FRANKLIN PK. ILL
SCALE NONE	NO. REQ'D PER.	
SCHEMATIC, DUAL POWER AMP, A082-90910-E000		PART NO. M051-00986-E011

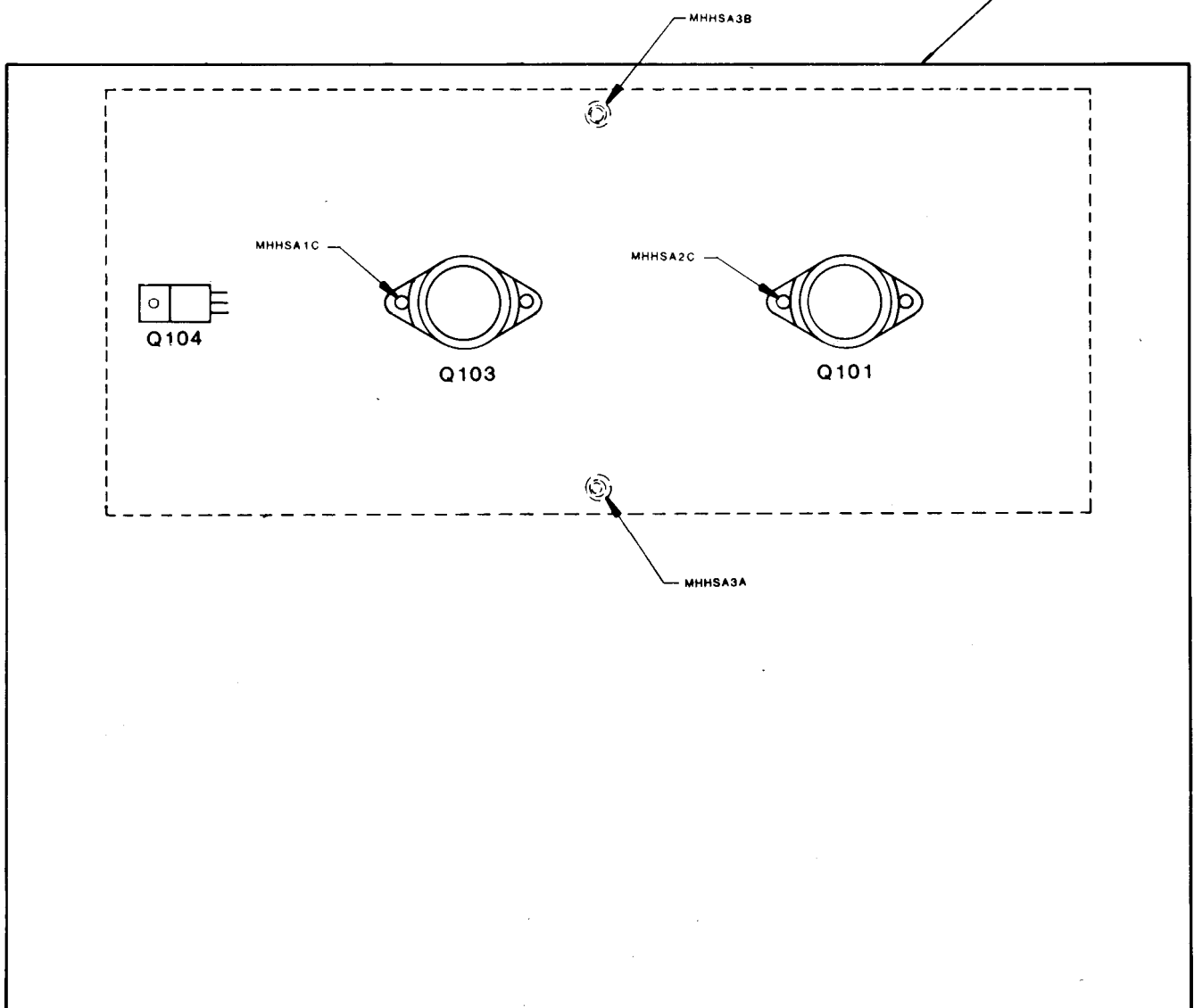
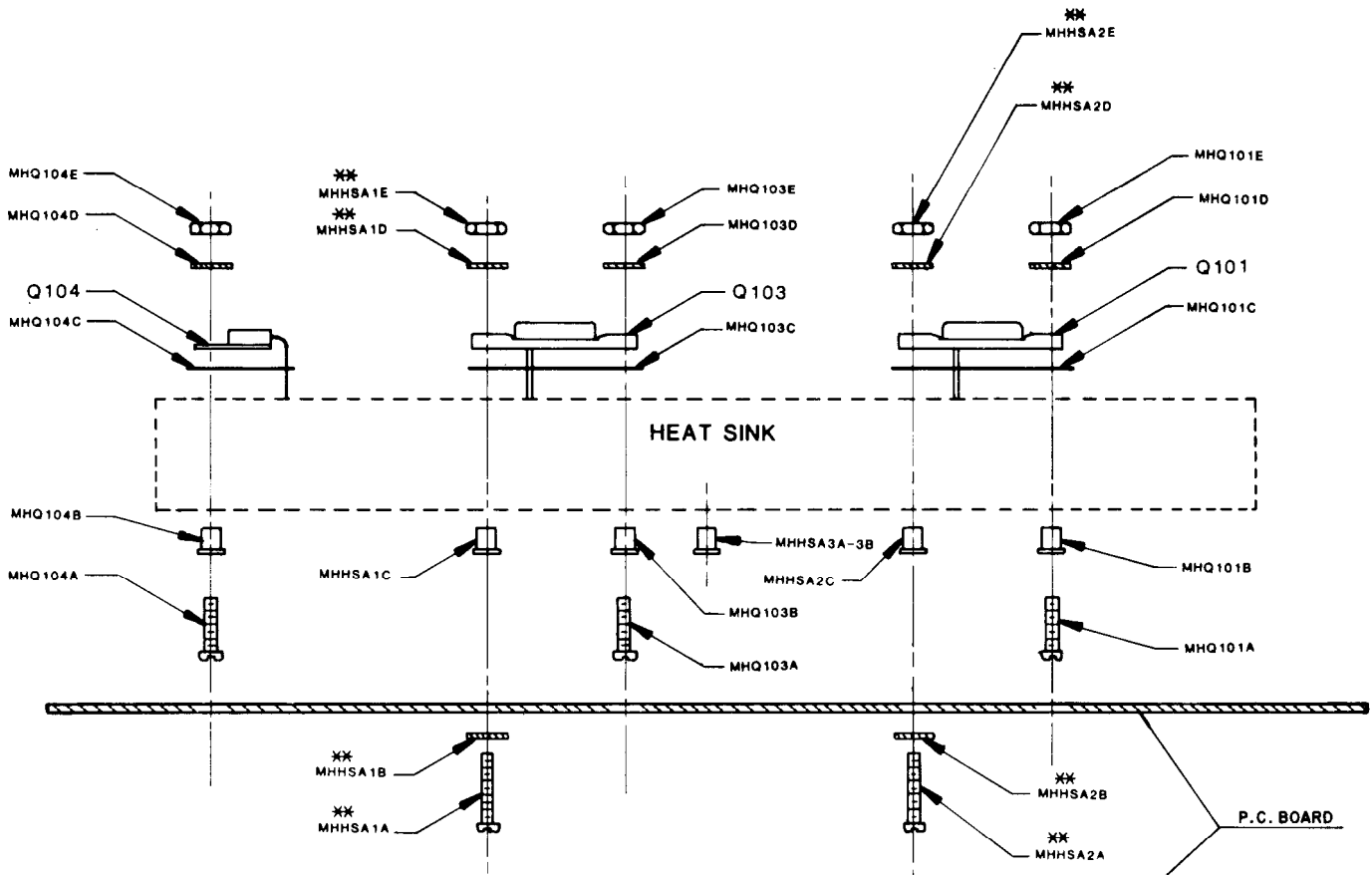

DESIGNATION LIST

DESIGNATION #	DESCRIPTION
Q101	2N3772 XSTR
Q103	2N3772 XSTR
Q104	TIP31
HS1	HEAT SINK
MH HSA1C	SHOULDER WSH
MH HSA2C	SHOULDER WSH
MH HSA3A,3B	SHOULDER WSH
MHQ101A	4-40X8 SLT PAN
	SHOULDER WSH
MHQ101C	INSL TO-3
MHQ101D	WSH 4-40-.250-018
MHQ101E	4-40 HEX NUT
MHQ103A	4-40X8 SLT PAN
MHQ103B	SHOULDER WSH
MHQ103C	INSL TO-3
MHQ103D	WSH 4-120-.250-018
MHQ103E	4-40 HEX NUT
MHQ104A	4-40X8 SLT PAN
MHQ104B	SHOULDER WSH
MHQ104C	INSL TO-220
MHQ104D	WSH 4-120-.250-018
MHQ104E	4-40 HEX NUT

CROSS REFERENCE LIST

DESCRIPTION	Q'ty	DESIGNATION #	PART #
2N3772 XSTR	2	Q101,103	0945-00808-0100
TIP31	1	Q104	0945-00808-0200
HEAT SINK	1	HS1	0945-00808-0000
4-40X8 SLT PAN	3	MHQ101A MHQ103A MHQ104A	0017-00101-0510
WSH 4-120-.250-018			
WSH 4-120-.250-018	3	MHQ101D MHQ103D MHQ104D	0017-00104-0071
SHOULDER WSH	7	MH HSA1C,2C MH HSA3A,3B MHQ101B MHQ103B MHQ104B	0945-00807-0000
INSL TO-3	2	MHQ101C MHQ103C	0945-00809-0300
INSL TO-220	1	MHQ104C	0945-00809-0600
4-40 HEX NUT	3	MHQ101E MHQ103E MHQ104E	0017-00103-0002

**** NOTE**

**** THIS ASSOCIATED HARDWARE IS ON POWER SUPPLY BOM AND SHOWN HERE ONLY FOR REFERENCE .**

PROJ. ENG; L. DEKKER		US'D ON KICK		MIDWAY MFG. CO.	
DO NOT SCALE DWG		SCALE	NO. REVD 1 PER	FRANKLIN PK ILL	
DIM TOLERANCES UNLESS SPECIFIED		MAT'L	HEAT SINK ASS'Y DRAWING		PART NO
UNSPECIFIED 1/16	DWN <i>CL</i>	FINISH			MO51 - 00945 - A008
FRACTIONAL 1/64	CKD <i>[Signature]</i>				
DECIMAL .005	DATE 9/1/82				
HOLE DIA ±.002 000					

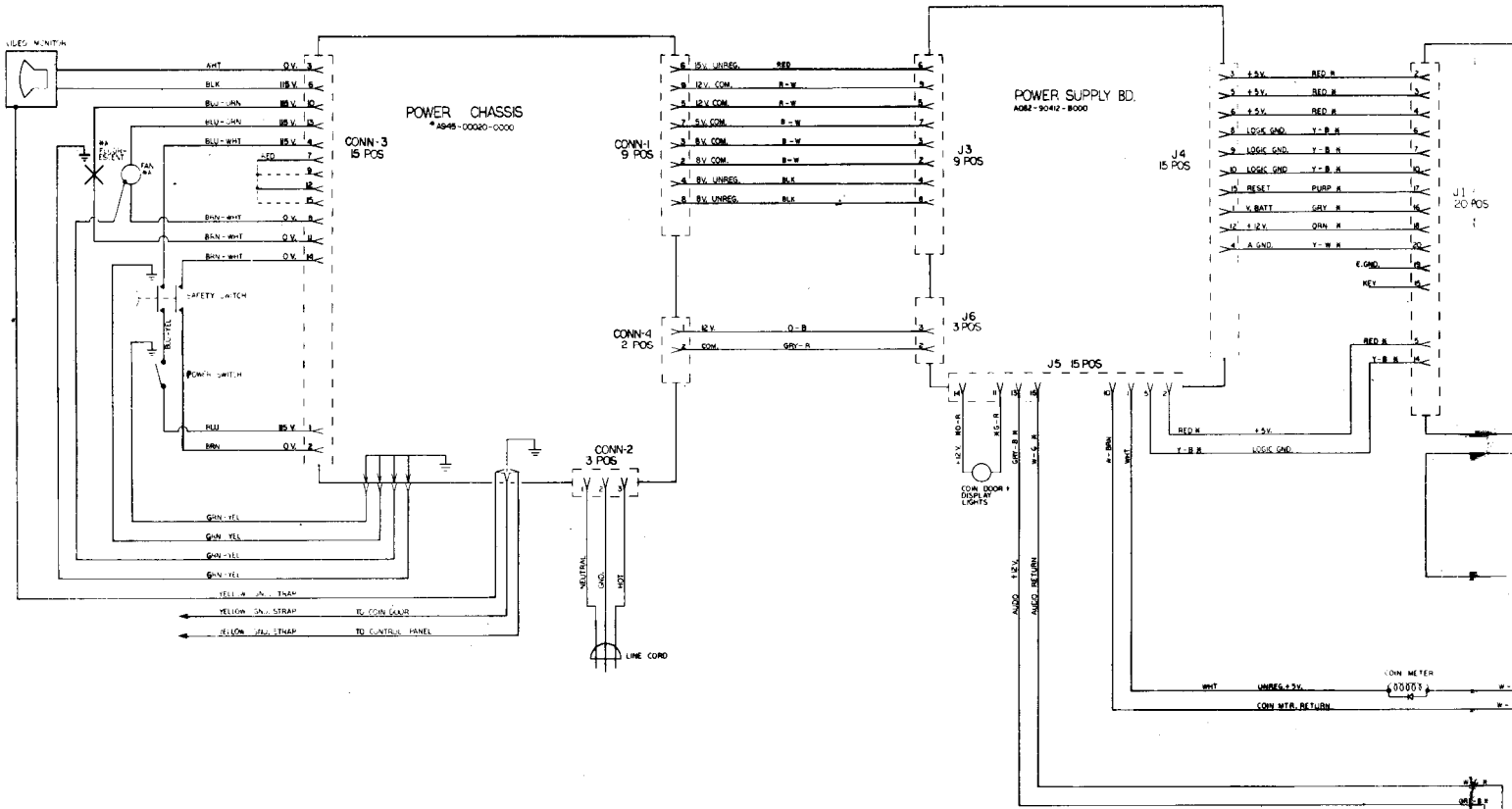

SATANS HOLLOW
 (ALL MODELS)
 MIDWAY MFG CO.
 10601 W. BELMONT AVE.
 FRANKLIN PARK, ILL. 60031

- NOTES:
1. R = RED WIRE
 2. A = #5A, 500V. WIRE
 3. G-Y GND. GOES TO ON-OFF SW. MONITOR, CONN DOOR, SPKR + CONTROL PANELS.
 4. AR = WHEN USED
 5. (---) = ALTERNATE COLOR

MONITOR JACK

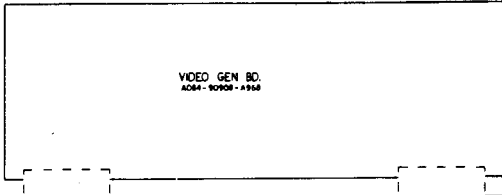
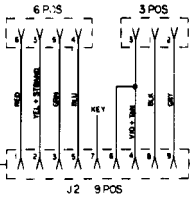

CPU BD.
A084-91999-A198

SOUND I/O BD.
A084-90009-A198

J5 23 POS

J4 19 POS

J6 10 POS

J3 9 POS

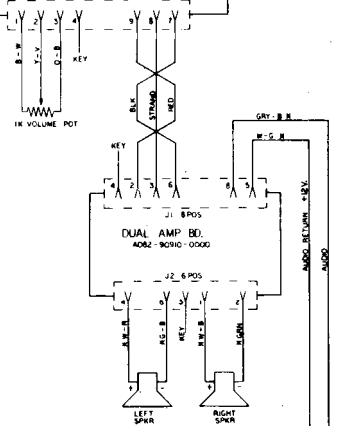
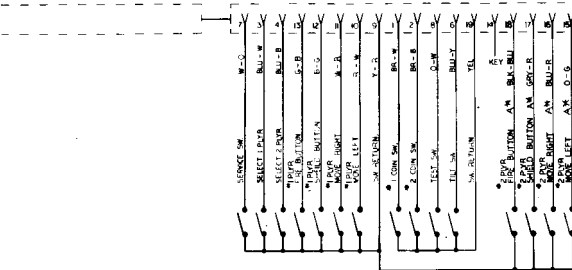

W-G-B
GRY-B-B
W-G-B
GRY-B-B
W-G-B
GRY-B-B
W-G-B
GRY-B-B

DESIGNATION LIST

DESIGNATION	DESCRIPTION
C101-C103	10MF 25V AX.TANT
C104-C127	.1MF 50V AX. CER.
C128-C129	47PF 50V AX. CER.
Q131	10MF 25V AX. TANT.
C134, C137	.1MF 20V AX. TANT.
C138	10MF 25V AX. TANT.
C139	.047MF 100V MYLAR
C140	.01MF 50V AX. CER.
C142	100PF 50V AX. CER.
C143	.1MF 50V AX. CER.
C144	33PF 50V AX. CER.
C145-C156	.0022MF 100V 10% MYLAR
C157-C159	.1MF 20V AX. TANT
C161	330PF 50V AX. CER.
C162-C164	.1MF 20V AX. TANT
C165	330PF 50V AX. CER.
C166, C167	10MF 25V AX. TANT.
I72	10MF 25V AX. TANT
C173	.01MF 50V AX. CER.
C501-C509	.1MF 50V AX. CER.
CP1	470MF 16V AX. ELECT.
CP2-C12	.01MF 50V AX. CER.
CP13	470MF 16V AX. ELECT.
CP14-CP19	.01MF 50V AX. CER.
CP20	10MF 25V AX. TANT.
CP21-CP27	.01MF 50V AX. CER.
CP29-CP33	.01MF 50V AX. CER.
CP34	10MF 25V AX. TANT.
CP35-CP46	.01MF 50V AX. CER.
CP47	470MF 16V AX. ELECT.
CP48-CP51	.01MF 50V AX. CER.
CP52, CP53	10MF 25V AX. TANT.
CP54	470MF 16V AX. ELECT.
CP202-CP204	10MF 25V AX. TANT.

DESIGNATION	DESCRIPTION
RM1	4.7K 10 PIN S.I.P.
RM2-RM5	2.7K 10 PIN S.I.P.
RM7	4.7K 8 PIN S.I.P.
RM8	820 OHM "
RM9	1.8K 10 "
RM14	4.7K 10 "
D101-D103	IN4148
D105-D107	IN4148
Q101-Q103	TIP110
Q104	2N4403
IC A1	7406
" A4	74LS273
" A5	74LS374
" A6	1K X 8 RAM
" A7	ROM/EPROM 0
" A8	" "
" A9	" "
" A10	" "
" A11	74LS245
" A12	Z-80 CPU
" A13	74LS08
" B2, B4, B5	74LS244
" B7, B8	74LS138
" B9	74LS670
" B10	74LS32
" B11	74LS670
" B12, B13	74LS138
" B14	74LS174
IC C6	7407
" C10	MC3403
" C11	74LS04
" C12	MC14024
" C13	7427
" C14	74LS367
" D3	LM3900
" D6	74LS02
" D7-D9	MC14016
" D11	74190
" D12	PROMSB2A
" D13	74166
" E2	74LS244
" E10	MC3403
" E11	74161
" E12	74126
" F2	74LS244
" F3-F5	74LS191
" F6, F7	AY-3-8910
" F8-F10	74LS191
" F11	7474
" F12	74S04
ICSA6-ICSA10	24 PIN IC SOCKET
" A12	40 PIN "
" D12	16 PIN "
" F6, F7	40 PIN "
J1, J2	24 PIN KK100 RT. ANGLE CONN.
J3	5 PIN KK100 "
"	3 PIN KK100 "
J4	13 PIN KK100 "
"	5 PIN KK100 "
J5	18 PIN KK100 "
"	4 PIN KK100 "
J6	7 PIN KK100 "
"	2 PIN KK100 "
JW1, JW2	JUMPER WIRE
LED 3	YELLOW LED
SW1	10 POSITION DIP
SW3	8 " "
SW4	PUSH BUT TON S.W.
XTAL 1	16 MHZ CRYSTAL
MHQ101-MHQ103	SNAP

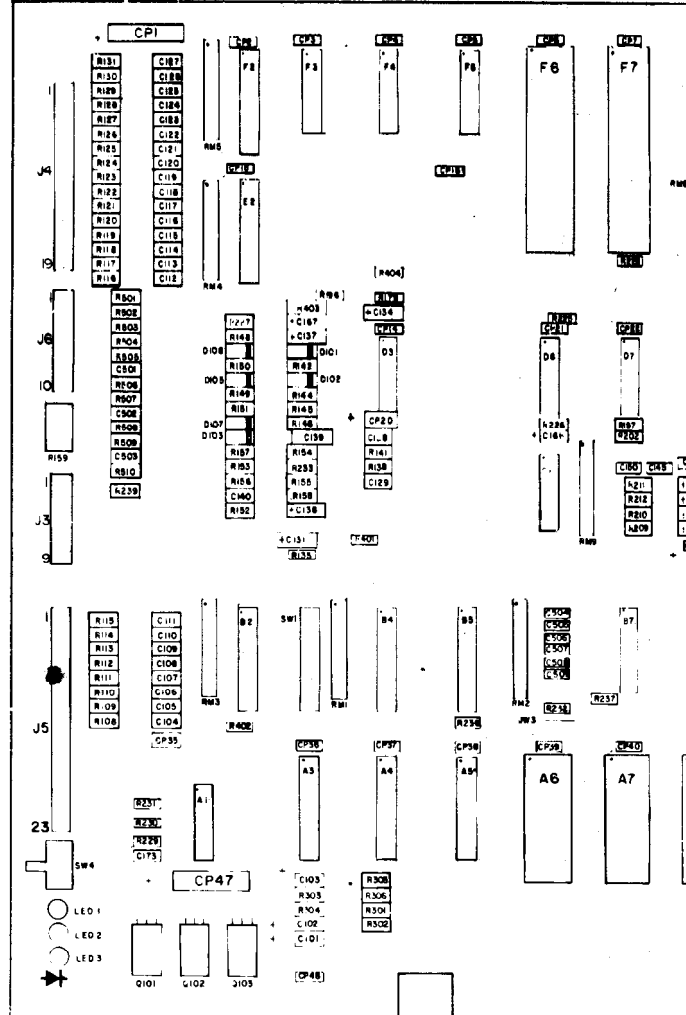

CROSS REFER

DESCRIPTION	QTY
33PF 50V 5% AX. CER	1
47 PF 50V AX. CER	2
100PF 50V 5% AX. CER	1
330PF 50V AX. CER.	2
.0022MF 100V 10% MYLAR	12
.047MF 100V MYLAR	1
.01MF 50V AX. CER	47
.1MF 50V AX. CER.	34
.1MF 20V AX. TANT.	8
10MF 25V AX. TANT.	15
470 MF 16V AX. ELECT.	4
22 OHM 1/4W 5% CARBON	1
100 OHM "	1
220 OHM "	34
300 OHM "	1
330 OHM "	2
1K "	3
1.2K "	3
2.7K "	7
3K "	1
4.7K "	19
5.6K "	12
10K "	4
13K "	6
24K "	2
27K "	2
33K "	15
100K "	2
180K "	2
620K "	4
1MEG. "	2

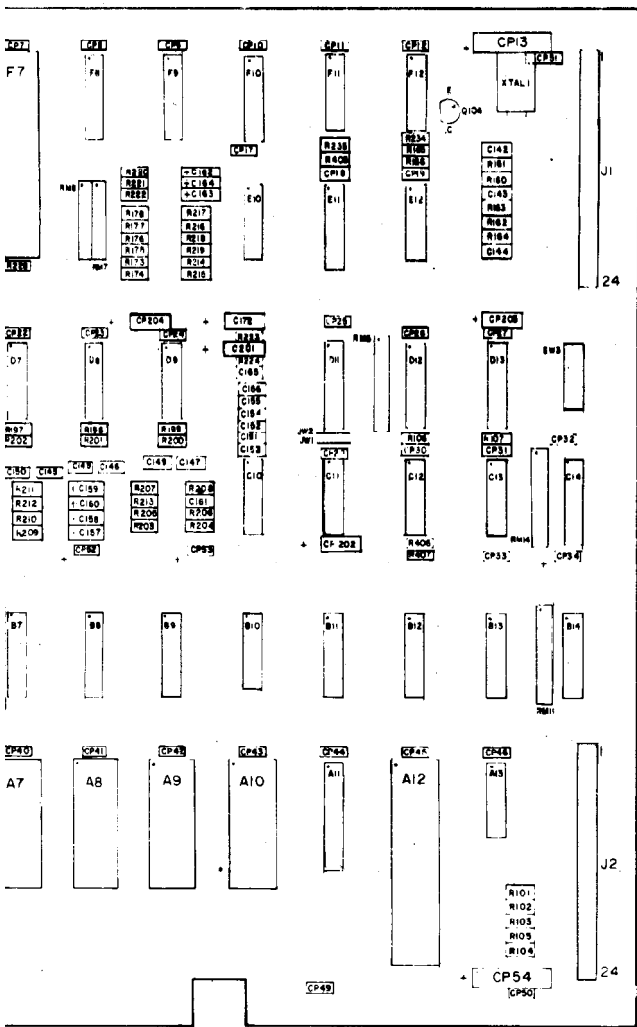

DESCRIPTION	QTY	DESIGNATION	PART NO.
820OHM 8PIN S.I.P.	1	RM8	0986-00805-0800
1.8K 10PIN S.I.P.	1	RM9	0986-00805-0600
2.7K 10PIN S.I.P.	4	RM2-RM5	0986-00805-0500
4.7K 8 PIN S.I.P.	1	RM7	0986-00805-0400
4.7K 10PIN S.I.P.	2	RM1, RM4	0986-00805-0300
IN4148	6	D10-D103, D105-D107	0986-00801-0200
2N4403	1	Q104	0986-00802-0500
T1P 110	3	Q101-Q103	0986-00802-0400
74LS02	1	D6	0986-00803-7400
74LS04	1	C11	0986-00803-6900
74S04	1	F12	0986-00803-6600
7406	1	A1	0986-00803-7600
7107	1	C6	0986-00803-5900
74LS08	1	A13	0986-00803-7300
7427	1	C13	0986-00803-7200
74LS32	1	B10	0986-00803-6100
7474	1	F11	0986-00803-6700
74126	1	E12	0986-00803-6800
74LS138	4	B7, B8, B12, B13	0986-00803-6500
74161	1	E11	0986-00803-5100
74166	1	D13	0986-00803-5300
74LS174	1	B14	0986-00803-7500
74190	1	D11	0986-00803-9400
74LS191	6	F3-F5, F8-F10	0986-00803-5600
74LS244	5	B2, B4, B5, E2, F2	0986-00803-4800
74LS245	1	A11	0986-00803-6400
74LS273	1	A4	0986-00803-4700
74LS367	1	C14	0986-00803-7000
74LS374	1	A5	0986-00803-4600
74LS670	2	B9, B11	0986-00803-6300
AY-3-8910	2	F6, F7	0986-00803-8500
LM3900	1	D3	0986-00803-4900
MC3403	2	C10, E10	0986-00803-5000
MC14016	3	D7-D9	0986-00803-6200
MC14024	1	C12	0986-00803-7100
PROM 5B2-A	1	D12	0986-00803-8200
RAM 1K X 8	1	A6	0986-00803-8000
ROM/EPROM 0	1	A7	EPROM/ROM OPTIONS KIT
" " 1	1	A8	
" " 2	1	A9	
" " 3	1	A10	
Z-80138800	1	A12	0986-00803-5500

REFERENCE LIST

16 PIN IC SOCKET	1	ICSD12	0986-00804-1400
24 PIN "	5	ICSA6-ICSA10	0986-00804-1600
40 PIN "	3	ICSA12, ICSF6, ICSF7	0986-00804-1500

DESIGNATION

PART NOS.

C144	0986-00800-0900
C128, C129	0986-00800-2800
C142	0986-00800-1000
C161, C165	0986-00800-1300
C145-C156	0986-00800-1200
C139	0986-00800-2600
CP2-CP12, CP14-CP19, CP21-CP27, CP29-CP33, CP35-CP46, CP48-CP51, C140, C173	0986-00800-2000
C104-C127, C143, C501-C509	0986-00800-1100
C134, C137, C157-C159, C162-C164	0986-00800-1400
CP20, CP34, CP52-CP53, CP202-CP204, C101-C103, C131, C138, C166, C167, C172	0986-00800-0700
CP1, CP13, CP47, CP54	0986-00800-2700
R164	0062-06383-1XXX
R239	0062-11083-1XXX
R108-R131, R162, R501-R509	0062-13383-1XXX
R231	0062-14183-1XXX
R160-R161	0062-14483-1XXX
R153, R227, R401	0062-17983-1XXX
R157, R158, R163	0062-18383-1XXX
R301-R306, R510	0062-1983-1XXX
R233	0062-20183-1XXX
R101-R107, R165, R166, R225, R226, R228, R232, R234, R235, R402, R405-R407	0062-21183-1XXX
R173-R178, R197-R202	0062-21583-1XXX
R146, R151, R155, R156	0062-22783-1XXX
R209-R211, R220-R222	0062-23383-1XXX
R179, R196	0062-24583-1XXX
R213, R224	0062-24783-1XXX
R135, R203-R208, R214-R219, R403-R404	0062-25183-1XXX
R142, R148	0062-27583-1XXX
R138, R141	0062-28783-1XXX
R144, R145, R149, R150	0062-31383-1XXX
R152, R154	0062-32383-1XXX

2PINK 100 RT. ANGLE CONN	1	J6	3000-16366-0200
3 PIN "	1	J3	3000-16366-0300
4 PIN "	1	J5	3000-16366-0400
5 PIN "	2	J3, J4	3000-16366-0500
7 PIN "	1	J6	3000-16366-0700
13 PIN "	1	J4	3000-16366-1300
18 PIN "	1	J5	3000-16366-1800
24 PIN "	2	J1, J2	0986-00804-4700
JUMPER WIRE	2	JW1, JW2	0986-00804-4000
YELLOW LED	1	LED 3	0986-00804-2000
8 POSITION DIP SW	1	SW3	0986-00805-0900
10 POSITION DIP SW	1	SW1	0986-00805-1000
PB SWITCH	1	SW4	0986-00805-1700
16 MHZ CRYSTAL W/3RD LEAD	1	X1AL	0986-00805-1100
SNAPS	3	MHQ101-MHQ103	0017-00007-0134

PROJ. ENG.: C. MEDNICK

DO NOT SCALE DWG		HEAT TREAT	SCALE	USED ON SATANS' HOLLOW	REVISIONS	
DIM TOLERANCES UNLESS SPECIFIED		MAT'L	FULL	NO RECD 1 (ONE)	MIDWAY MFG. CO.	
UNLESS OTHERWISE SPECIFIED		FINISH	COMPONENT LAYOUT DRAWING		FRANKLIN PK ILL	
DATE 9/1/82		SUPER SOUND I/O P.C. BRD.		PART NO. M051-00941-A016		
A084-90913-A941						

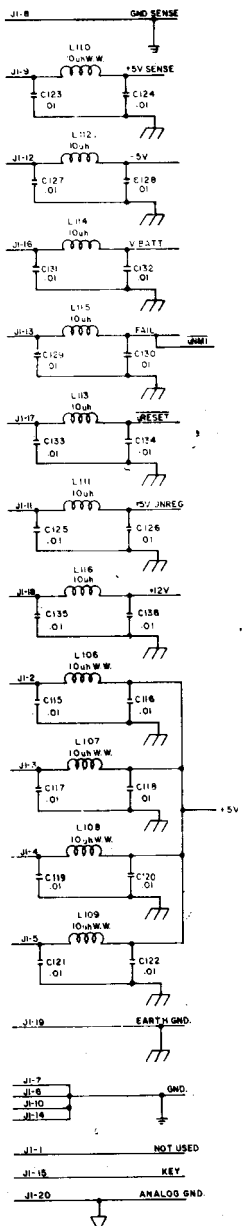
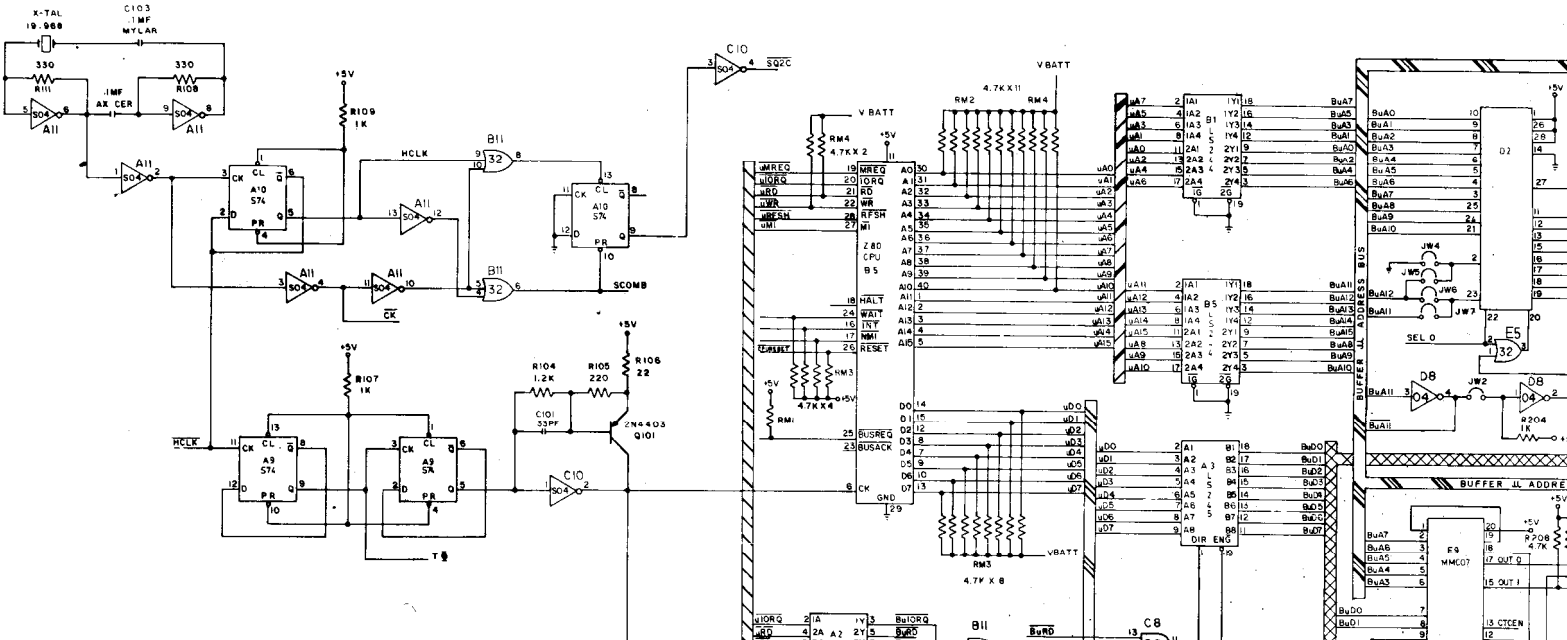

72 PIN TEST CONNECTOR		v3		v4		v5		v6	
1	L GND	27	AC	49	JW1	1	L GND	1	L GND
2	+5V	28	A1	50	INT	2	A GND	2	BUFF
3	L GND	29	A2	51	INT	3	L GND	3	L GND
4	+5V	28	A3	52	FLIP	4	+5V	4	PJ6
5	+12V	29	A4	53	RES	5	+5V	5	PJ6
6	L GND	30	A5	54	TR	6	+5V	6	PJ6
7	+12V	31	A6	55	RESET	7	L GND	7	PJ6
8	V BATT	32	A7	56	T	8	L GND	8	PJ6
9	+5V	33	DISDOG	57	CLKCTL	9	L GND	9	PJ6
10	L GND	34	INT	58	INT	10	L GND	10	HCLK
11	L GND	35	FLIP	59	WAIT	11	L GND	11	RSELO
12	+5V	36	HELMK	60	HELMK	12	L GND	12	L GND
13	L GND	37	HELMK	61	HELMK	13	L GND	13	L GND
14	+5V	38	JZREG	62	HELMK	14	L GND	14	MOVE BUF
15	L GND	39	L GND	63	L GND	15	L GND	15	BZ2
16	+5V	40	VPFSH	64	REC	16	L GND	16	D/D
17	VID 0	41	HELMK	65	L GND	17	DISDOG	17	D/D
18	VID 1	42	HELMK	66	GREEN	18	L GND	18	DV2
19	VID 2	43	A10	67	L GND	19	+5V	19	DV2
20	VID 3	44	A11	68	BLUE	20	D/D	20	D/D
21	MOVE BUF	45	A12	69	L GND	21	L GND	21	D/D
22	INT	46	A13	70	+5V	22	L GND	22	D/D
23	INT	47	A14	71	L GND	23	L GND	23	D/D
24	INT	48	A15	72	+5V	24	L GND	24	D/D

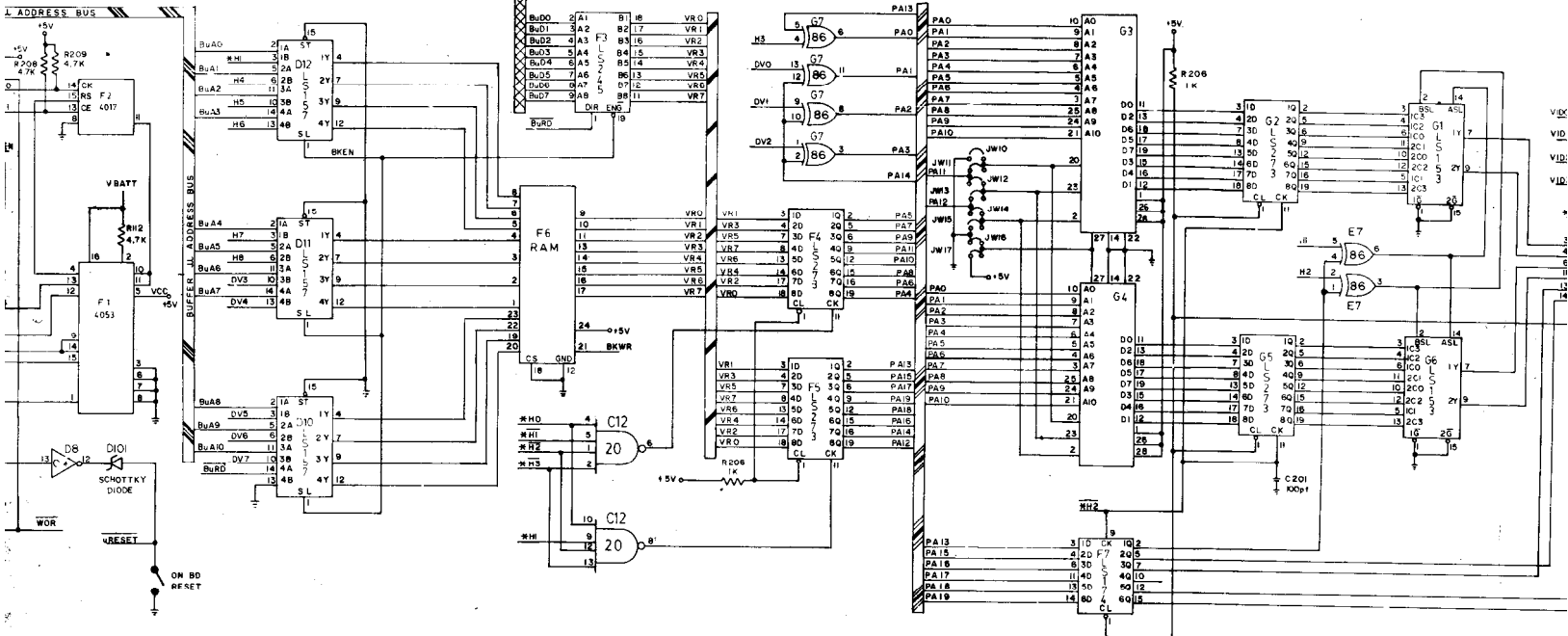
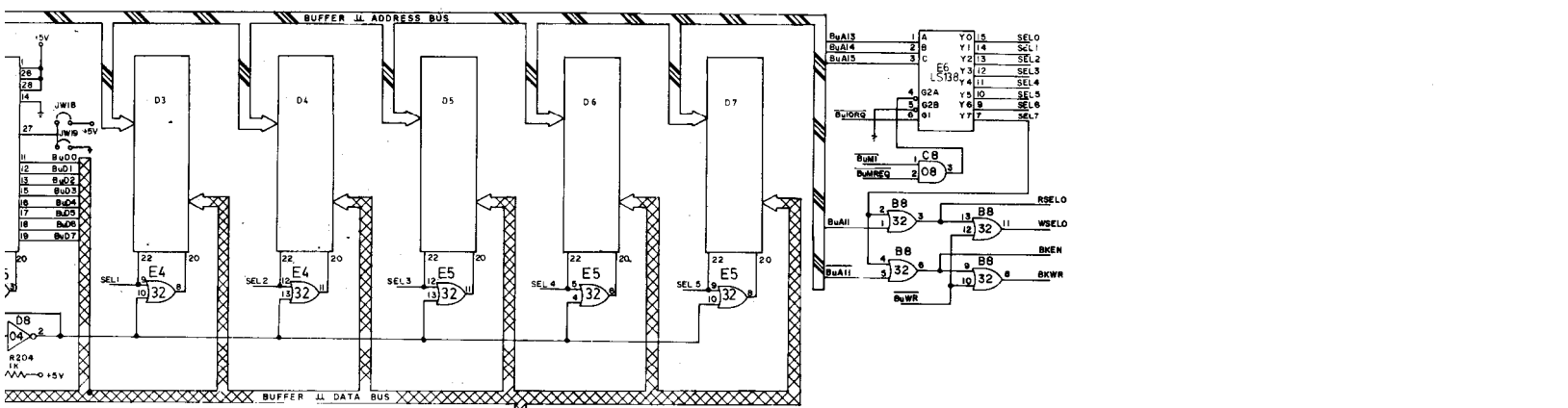

- #0 1 GND
- #1 2 L GND
- #2 3 GND
- #3 4 L GND
- #4 5 BLUE
- #5 6 L GND
- #6 7 KEY
- #7 8 HBLNK
- #8 9 VBLNK
- #9 10
- #10 11
- #11 12
- #12 13
- #13 14
- #14 15
- #15 16
- #16 17
- #17 18
- #18 19
- #19 20
- #20 21
- #21 22
- #22 23
- #23 24
- #24 25
- #25 26
- #26 27
- #27 28
- #28 29
- #29 30
- #30 31
- #31 32
- #32 33
- #33 34
- #34 35
- #35 36
- #36 37
- #37 38
- #38 39
- #39 40
- #40 41
- #41 42
- #42 43
- #43 44
- #44 45
- #45 46
- #46 47
- #47 48
- #48 49
- #49 50
- #50 51
- #51 52
- #52 53
- #53 54
- #54 55
- #55 56
- #56 57
- #57 58
- #58 59
- #59 60
- #60 61
- #61 62
- #62 63
- #63 64
- #64 65
- #65 66
- #66 67
- #67 68
- #68 69
- #69 70
- #70 71
- #71 72
- #72 73
- #73 74
- #74 75
- #75 76
- #76 77
- #77 78
- #78 79
- #79 80
- #80 81
- #81 82
- #82 83
- #83 84
- #84 85
- #85 86
- #86 87
- #87 88
- #88 89
- #89 90
- #90 91
- #91 92
- #92 93
- #93 94
- #94 95
- #95 96
- #96 97
- #97 98
- #98 99
- #99 100

NOTES:
 A=ANALOG
 E=EARTH
 L=LOGIC
 N.U.=NOT USED

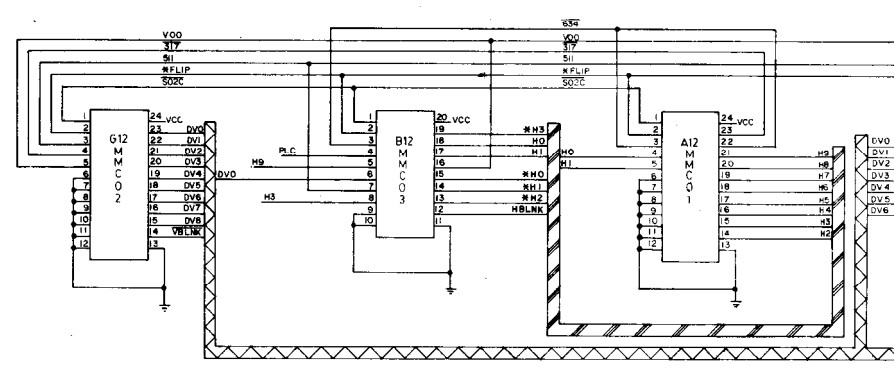

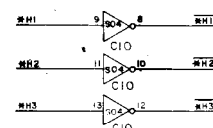
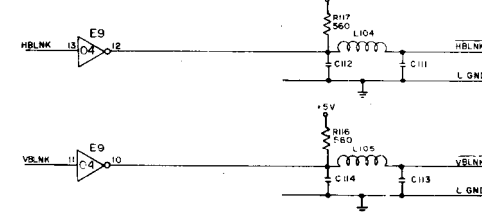
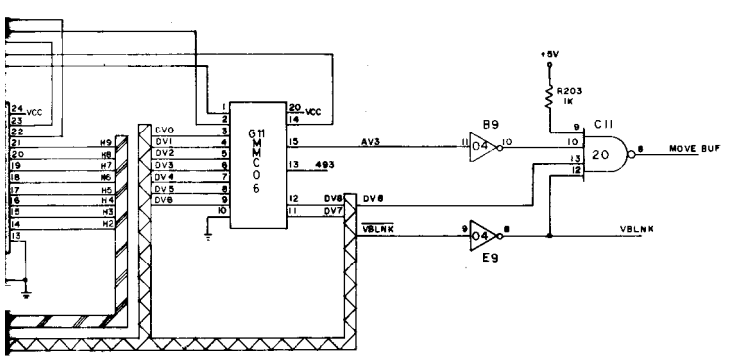
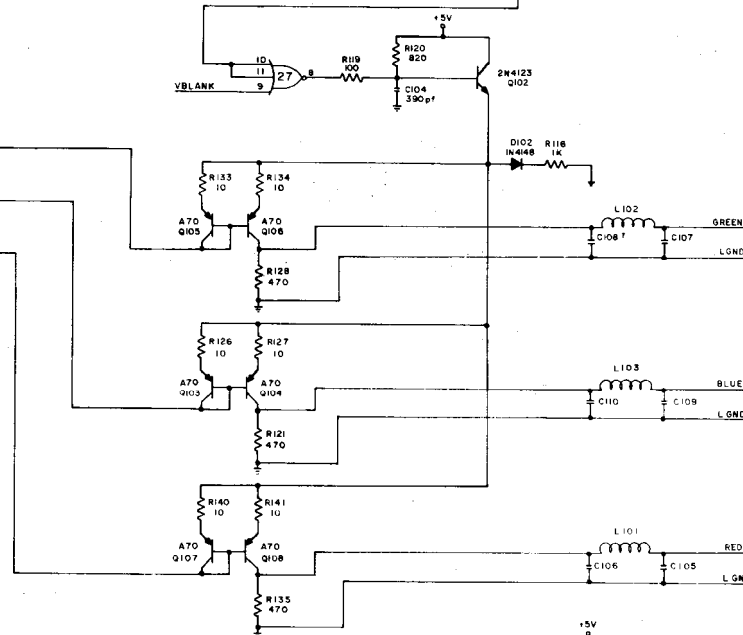
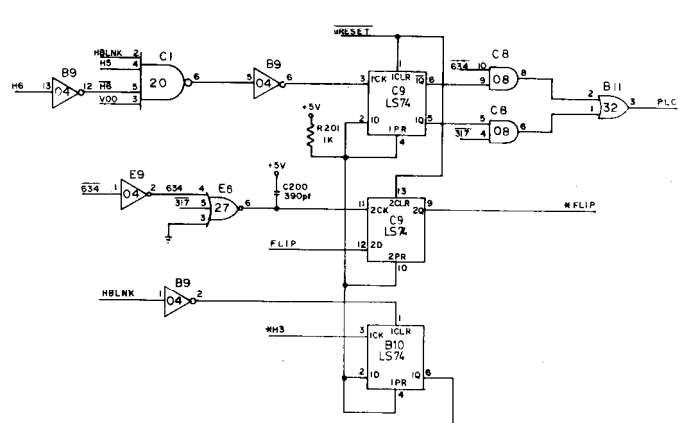
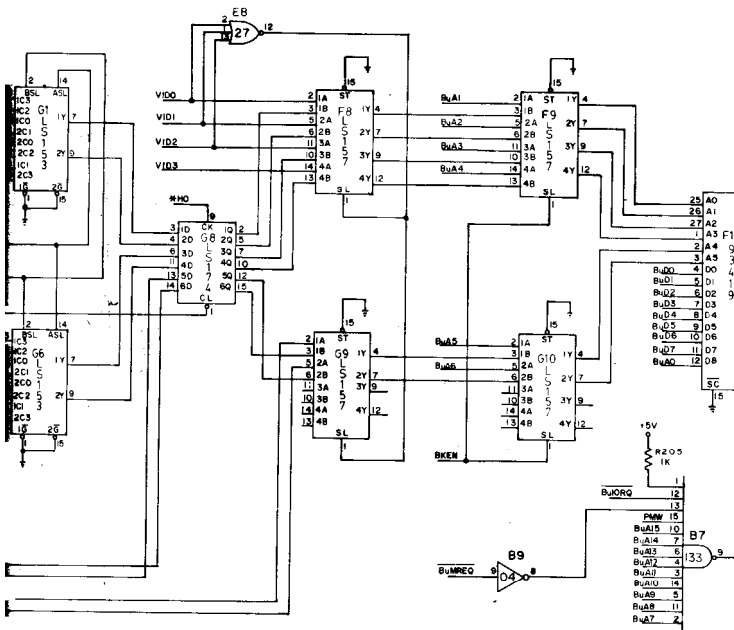

PROJECT ENG	A. GHOSH	DESIGNED BY	A. GHOSH	DATE	9/7/82
NO. OF SHEETS	1	TITLE	SCHEMATIC DRWG SUPER CPU	REV. NO.	1
DATE	9/7/82	BY	A. GHOSH	CHKD BY	
PROJECT NO.			A082-90010-E000	MFG. CO.	
PROJECT NAME			NO REED 1 (ONE)	MIDWAY MFG. CO.	
PROJECT NO.			M051-00986-E014	MFG. CO.	