

SUPER SKIDMARKS





Super SkidMarks Manual Contents

- Introduction
- New Features
- Memory and System requirements
- Building a 4 player joystick adapter
- Super SkidMarks User Interface
- HD Installation
- Racing With Super SkidMarks
- Imagine2 Converter
- SkidMarks Racer Magazine
- Credits and Greetings

Introduction

This package was suppose to be an upgrade that was due to be released several months after the original SkidMarks was completed (December 93). It was originally intended that we would release a new track editor that would be friendly enough for users to create their own tracks.

Sadly it was not to be and several months later, we decided to simply add another two track disks to the original package. These were completed some 6 months ago.

We then found that by using a different sprite system we could have 8 cars with AGA machines and set about redesigning the sprite converter which we are proud to announce has been included in this release for users to add their own cars.

With new cars and new tracks we then thought a quick rewrite of the front end was in order. That was 6 months ago.

It may be due to bad management, too many other projects to distract us, general laziness, or just bloody mindedness but Super SkidMarks is finally finished, we hope it was worth the wait...

New Features

- New 8 car mode for AGA machines
- Shared screen mode for up to 4 player team racing
- Triple split screen mode for three players on one Amiga
- Caravan towing, wo! what a holiday!
- 12 new tracks as well as compatibility with original 12
- New cars including Mini, VW, F1, Cow and Midget
- New Acid Intelligence technology for computer drivers
- Super view mode for locally linked AGA machines
- Improved comms support for local and remote linking
- Competition play with a multitude of challenging series
- Imagine2 SkidMarks car converter for user defined cars

Memory and System requirements

Super SkidMarks should run on any Amiga with 1 megabyte of memory.

Those with more memory will be able to have more than one type of car racing at once and may even have some music to listen to while selecting options.

Those with AGA Amigas can enjoy the new hi-res screen modes as well as racing 8 cars at once.

Modem owners can enjoy Super SkidMarks improved comms support and race against others over the phone lines.

Super SkidMarks also supports 4 joystick adaptors. This device connects two extra joysticks to an Amiga via the parallel port. A wiring diagram is included in this manual that illustrates how to build such a device.

Building a 4 Player Joystick Adapter

Below is a diagram to wire up a 4 joystick adapter to your Amiga. The simplest and possibly cheapest method is start with a standard printer cable. Remove the casing on the DB25 end (computer end) so you can see what colour wires are connected to which pins then cut off the connector at the other end of the cable (printer end) and strip off an inch of shielding.

As both joystick connectors require GND (pin 17) and 5V (pin 14) unsolder the wires connected to pin 18 and 15 on the DB25 connector and solder them on top of pins 17 and 14 respectively. This will give you two wires at the other end for the extra GND and 5V required by the second joystick connector. The best thing to do then is write on the diagram above the colours of each of the wires you will be connecting to JOY3 and JOY4. Then tint the wires (add solder to them before soldering to connectors) and solder them to the joystick connectors. Good Luck!

IMPORTANT NOTICE

Acid Software or its retailers can accept NO responsibility for ANY problems that may arise from building a 4 player joystick adapter.

4-JOYSTICK (A500/2000/3000/4000)

Drawing:
Hans Luyten

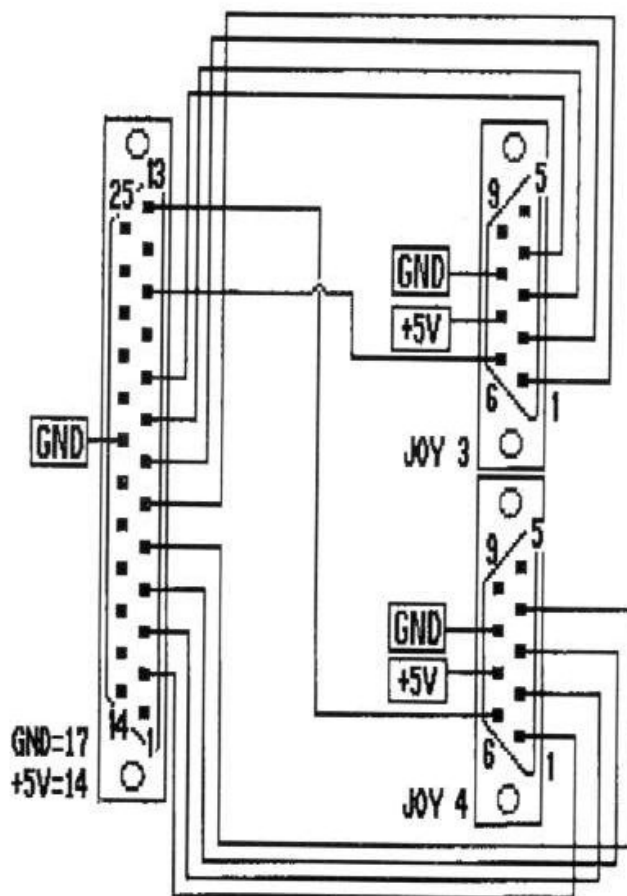

Parts:
2x SubD-9 (Male)
1x SubD-25 (Male)
CAUTION!

For Gauntlet II you
need to connect pin
6 of JOY 3 to pin
13.

Of joy 4, pin 6
should be connected
to pin 12.

This works with
games like:

- Kick Off 2
- Pro Tennis Tour II
- Dyna Blaster
- etc.

The Super SkidMarks User Interface.

Super SkidMarks includes numerous new options which can all be accessed via the user interface. Using the mouse, joystick or arrow keys select an option by highlighting the gadget and pressing the button or Return Key.

Often the Esc key on the keyboard can be used to exit from one options page back to a previous one.

Certain gadgets allow the user (you) to enter some text. After clicking on such a gadget a cursor appears. From the keyboard type in the text and hit return. With a joystick use up and down to change the character under the cursor, left and right to move the cursor and fire when finished.

HD Installation

Those with a hard disk system will want to install Super SkidMarks onto their hard disks. From WorkBench simply drag the Super SkidMarks drawer on the program disk onto your hard disk, this will copy all the files required to run Super SkidMarks from your hard disk. Then click on the HDCar install utility. This will unpack the cars from the data disks onto your hard disk. Unfortunately we are unable to offer the opportunity to do the same with the track disks at this time, we are sadly not in the position to risk sales because of the nature of piracy still rampant in the Amiga community. However we promise to include a TrackDisk install utility in the first issue of the "SkidMarks Racer" magazine (see later in this manual for details).

Racing with Super SkidMarks

Instead of a large section on what buttons to press and where, along with a detailed description of when and where to slow down and speed up, the following is a quick list of helpful hints and tips to get you in the spirit of things...

- Stay cool, a frustrated driver is a bad driver.
- Taking your finger off the button is uncool (see above).
- Use the horn to vent frustration (pull down on joystick).
- Drunk driving is for idiots, crash for the night or call a cab.
- Bouncing off other cars is an essential skill, practice it.
- Telling people to buy SuperSkidMarks will make you friends for life.
- Subscribing to SkidMarks Racer is a totally wise thing.
- Writing SkidMarks poetry is good for the soul.
- Banging on big drums dancing naked is good for you too.
- Approaching corners at a wide angle is sensible.
- Pulling 360 degree turns in mid air is not.
- Racing the formula one series is for nutters.
- Winning the formula one series is insane.
- Building a 4 Joystick Adapter is a rewarding project.
- Racing backwards with Caravans attached can be tricky.
- Replacing audio samples in the sfx drawer with your own is possible.
- Sending email to acid@iconz.co.nz may get results.
- Adding memory to your Amiga allows greater variety of cars in races.
- Driving two cars at once is an interesting possibility.
- High speed mid air collisions are to be encouraged.

Creating your own SkidMarks cars in Imagine

Included on the Super SkidMarks program disk is a drawer containing the files you need to add your own cars to SkidMarks. You will of course need access to Imagine2 .

Rendering In Imagine

Some familiarity with Imagine is required for those wanting to add their own cars to Super SkidMarks. A sample object has been included.

1. Copy the Kart drawer from the program disk onto your hard disk.
2. Run Imagine 2.
3. Open the SkidMarks project which can be found in the Kart drawer.
4. Open the Kart subproject.
5. Select all frames and then select Render.

Note:

Select Preferences in Imagine and check that the EDLE variable is set to 255 resulting in the best anti-aliasing Imagine has to offer.

The latest version of Imagine 3 we have is still unable to treat a genlock background properly and hence produces poor results when rendering SkidMarks cars (anti aliases the car to the back ground colour... yuck!).

Rendering your own Car.

To render your own car you must still use the SkidMarks project file included on the disk. This contains among other things:

- correct angles for the 800 rotations
- best iso-metric lens setting
- bright green genlock background colour required by converter
- correct file format (ILBM 24 bit)
- correct light sources and angles

First up, from the detail editor load the Kart and your own car. Scale your own car to that of the Kart. Then orient it's global axis to that of the karts:

- Select your car
- Press Shift R (rotate global axis)
- point x-axis forward
- point z-axis straight up
- point y-axis towards left side of car
- Press Shift M (move global axis)
- position axis in centre of car 3 units above ground level
- Save your car

You may also need to change your car's colours to suit SkidMarks. Use only Reds, Blacks, Greys and Whites.

To render your own car, go to the ActionEditor and select the red bar in the "TYRES" field. Replace the kart.job filename with that of your own car. Save changes and render the first 32 frames of your car.

Then run the converter program supplied on the program disk. Click on Select-File and find the first frame of the car you just rendered. skidmarks.imp/kart.pix/pic.001 or some such.

Then click on Show-AGA to view the first 32 frames in SkidMarks format. You may need to change the x and y offsets to centre your car in the frame, more than likely you should alter the objects axis position and size from within Imagine.

The four variables on the right of the screen adjust the dithering limits used by the converter. By changing these variables and then clicking on a frame of the car below you can fine tune how different shades are reproduced by the converter.

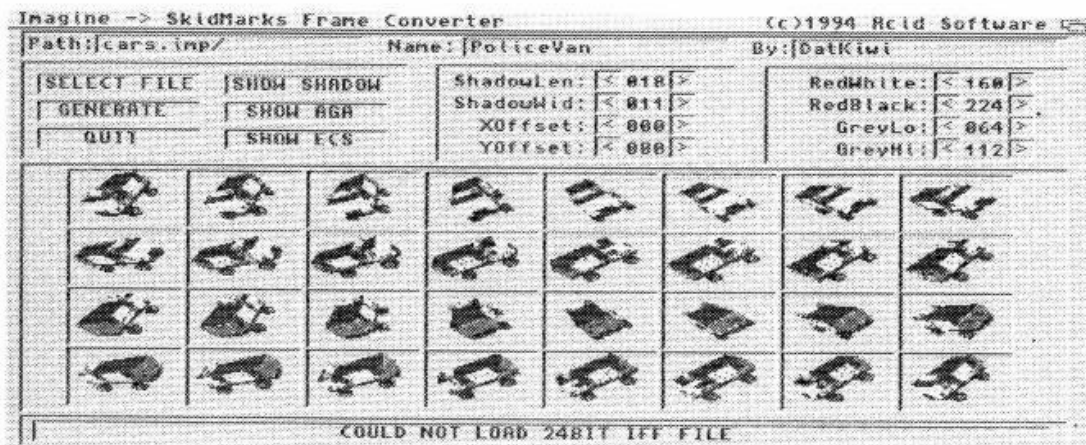

Problem Solving...

- if your car is being clipped it is either too large or it's axis is not correctly centred, the x offset variable in the converter may also require adjustment.
- If your car points in the wrong direction when driven the orientation of the axis needs adjusting (see the rotate global axis description above).
- If your car looks like crap the chances are you need to change the colour attributes in the detail editor. We only use red (255,0,0), black (0,0,0), grey (160,160,160) and white (255,255,255) colour settings.
- Turn off phong shading for all attributes as it simply slows down rendering, increase specularly for panels you want to reflect light (body and windows but not tyres), don't bother trying to use textures.
- Make sure for tyres that reflection and specularly are off, nothing looks worse than shiny tyres.
- If your car looks too good (better than any in the Acid garage) then please send us a file, we might even offer you some money or even a job.
- If you are having problems adding textures to faces then don't bother, the best method of adding small detail to cars is to attach objects in the form of 3D text or structured drawings.

Subscribe to the SkidMarks Racer Magazine

Publishing our own magazine will enable us to release new tracks and better versions of upgrades, run competitions and most of all keep in touch with all you SkidMarks racers. Send the enclosed registration card in today!

All being well the first issue of SkidMarks Racer will be mailed first week of June and we plan to include the following:

Colouring Competition

Two new tracks will be included in issue one of SkidMarks racer. Your job will be to add the trackside detail using your favourite Amiga paint program.

Car Modelling Competition

After the success of the "Imagine Build my Hot Rod Competition" in Amiga Format last year we want to do it all again. This time however we will be expecting the entries to be "race ready" using the Imagine2 SkidMarks converter included on Super SkidMark's cover disk.

Full HD Installation Utility

Subscribers to SkidMarks Racer will at some time also receive a utility to install the 4 SkidMarks track disks on their hard disk.

GrandPrix License

All those who fill in the GrandPrix registration section will be listed in the magazine. We'll encourage everyone to contact others in their

area to organise race meetings at a local venue and/or run tournaments using a BBS to schedule playoffs.

Articles Wanted

If you have a story to tell be it about driving your own car or a party you had where everyone ended up playing SkidMarks till the sun came up we want to hear about it. Any hints and tips regarding driving, setting up your modem etc, would be also greatly appreciated

Credits

Andrew Blackbourn	- Programmer
Simon Armstrong	- Mechanic
Rodney Smith	- Artist #1
Hans Butler	- Artist #2
Anthony Milas	- Musician
Mark Sibly	- Blitz Guru
Kurt Butler	- Buildings
Sonic	- Novice
Ted Bailey	- Moo Man
Giles Hunter	- Long Distance Nag Man
Greetings Blitz Users	- what a bunch
Marcus Dyson	- what a dude
Net Surfers	- what a waste

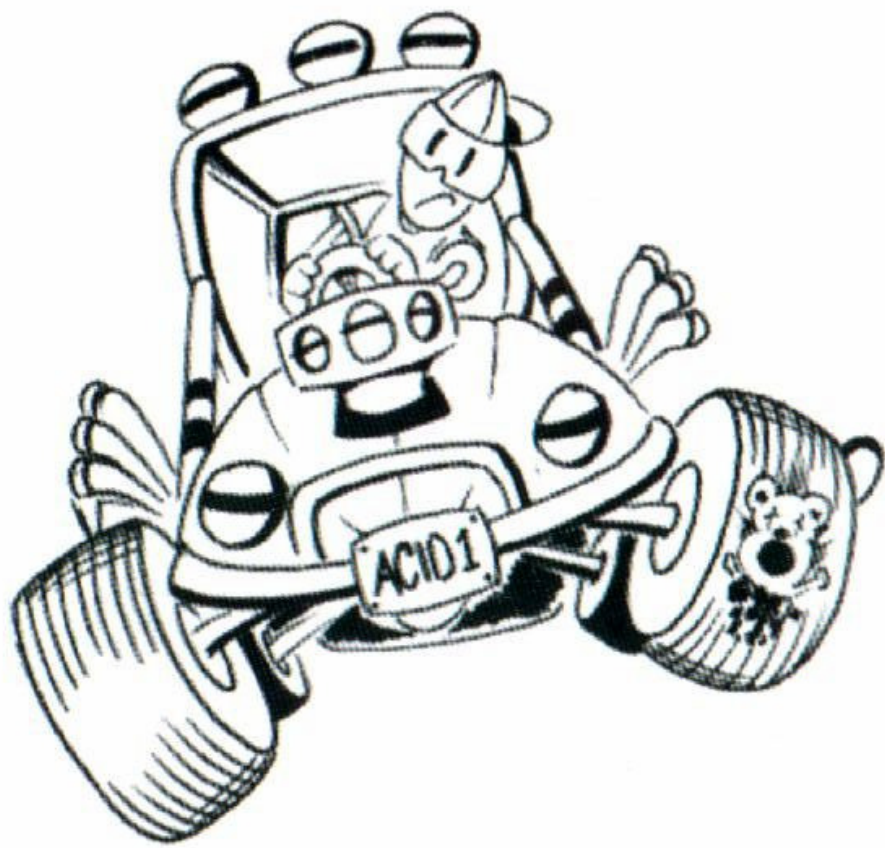



SUPER SKIDMARKS OFFICIAL REGISTRATION CARD

To receive your **FREE** copy of Super Skidmarks Magazine in May/June and your **FREE** Acid Attack Poster please put a stamp on the back of this card and return to Unit 15, Guildhall Industrial Estate, Kirk Sandall, Doncaster, S.Yorks. DN3 1QR. England. You will then be officially registered and will receive your **FREE** Magazine & Poster ASAP.

NAME:

ADDRESS:

AMIGA 500/600 CD-32 CD-ROM

AMIGA 1200 PC Future Releases

If you want to receive information about future releases, please put a stamp on the reverse of this card and return to Unit 15 Guildhall Industrial Estate, Kirk Sandall, Doncaster, S. Yorks, DN3 1QR. England. You will then be officially registered.

Affix
Stamp
Here

**ACID SOFTWARE
DISTRIBUTION CENTRE
UNIT 15,
GUILDHALL INDUSTRIAL ESTATE,
KIRK SANDALL,
DONCASTER,
SOUTH YORKSHIRE
DN3 1QR.**

Guildhall Leisure Services

Customer/Retailer Product Information

Thank-you for buying this game, we hope it gives you plenty of enjoyment. We thought it would be a good idea to let you know what other software we do for your computer. The list overleaf may include titles not yet released but please ask your local retailer for information.

All these games should be available from your retailer and if they or you would like any more information please call.....

***Guildhall Leisure Services
on 01302 890000***

.....we will only be too happy to assist.

AMIGA CD~32

Current Titles

Bubble & Squeak

*Two great characters, Thirty huge levels
Ten bonus levels, Five tough shoot'em ups
Incredible gameplay!*

Wembley International Soccer

*Superb graphics and realistic animation
combine with gameplay that's so true to life
you'll be on the edge of your seat cheering!
Endorsed by the famous stadium.*

Guardian

*Stunning defender type shoot'em up.
Featuring state of the art 3D graphics and
sound. A no-nonsense blaster.*

Super Methane Brothers

*Classic platform puzzle game. Colourful,
noisy and fun.*

Roadkill

*" A seriously dangerous racing challenge
boasting the kind of gut wrenching
playability you only dream of. "
" Roadkill astonishes with it's outstanding,
adrenalin pumping action... a superb follow
up to Skidmarks and Guardian. "*

December

Strip Pot

*Genuine adult collectors game
with beautiful opponents BBFC 18*

December

Skidmarks

*Stunning off road simulation, which
encompasses both the original and all the
extra tracks & cars.*

January

Blitz Carry Out Compilation

*Compilation of Blitz Software titles
developed using Amiga programming
language - Blitz Basic.
A must for Amiga lovers*

Super Loopz

*An addictive puzzle game that'll keep you
awake at nights - a coin op classic.*

Super League Manager

*The 1st role - playing management game,
challenging and compelling.*

Exile

*First of a new breed of true arcade
adventure games, featuring Virtual
Environment with realistic simulation of
natural forces. Vast playing area, Onni -
directional smooth scrolling. Hundreds of
puzzles to solve. Artificially intelligent
creature robots to battle against or
be-friend. Atmospheric spatial sound
effects.*