

# SHANGHAI: TRIPLE-THREAT

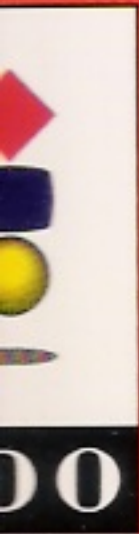

3DO, the 3DO logos and Interactive Multiplayer  
are trademarks of The 3DO Company.

ACTIVISION



# TABLE OF CONTENTS

<b>THE HISTORY OF SHANGHAI</b> .....	2
<b>GETTING STARTED</b> .....	4
<b>USING THE CONTROL PORT</b> .....	5
<b>USING THE 3DO MOUSE</b> .....	6
<b>PLAYING THE GAMES</b> .....	7
<b>Classic Shanghai</b> .....	7
<b>Matching the Tiles</b> .....	8
The Mah-Jongg Tile Set .....	9
The Zodiac Tile Set .....	10
The Music Tile Set .....	11
<b>The Great Wall</b> .....	12
<b>Beijing</b> .....	13
<b>Golden Tile</b> .....	15
<b>ORIGINAL MODE</b> .....	16
<b>The Options Menu</b> .....	16
<b>ARCADE MODE</b> .....	20
<b>The Configuration Menu</b> .....	21
<b>Entering a Password</b> .....	22
<b>Arcade Mode Items</b> .....	23
<b>Strategy and Tips</b> .....	24
<b>The Bonus Level</b> .....	24
<b>Ranking</b> .....	25
<b>The Great Wall of China</b> .....	25
<b>CUSTOMER SERVICE</b> .....	27
<b>CREDITS</b> .....	28



# THE HISTORY OF SHANGHAI

The success of *Shanghai* can easily be attributed to its inarguably addictive gameplay. Simple to learn yet difficult to master, it is not surprising that *Shanghai* has developed a tremendous following. Among dedicated Shanghai followers are mostly adults, but since anyone can learn to play, anyone who is exposed to the game is sure to get hooked. Shanghai's legion of addicted players hunger for the challenge of new ways to play with Mah-Jongg tiles — ways that only the power of computers can make possible. It is in this that the secret of Shanghai's success lies.

Although *Shanghai* is played with Mah-Jongg tiles, there is no similarity in the way the two games are played. Think of *Shanghai* as "solitaire," and Mah-Jongg as "Bridge" or "Gin Rummy." Mah-Jongg requires four players and is a complicated betting game. *Shanghai* uses Mah-Jongg tiles but is a one- or two-player game that is considerably easy to learn; the difficulty is simply in one's attempt at mastering the game.

In 1986, Activision released the original Macintosh version of *Shanghai* and introduced a captivating new way to use the Mah-Jongg tiles. By today's standards, the original *Shanghai* was fairly primitive: there was no 3-D perspective or shadowing, it was all in black and white, and it included only one layout and a single tile set! That same year, *Shanghai* was ported to eight platforms (machines) in the United States.

The following year, *Shanghai* made its way to Japan and was an immediate "Dai Hitto" (Big Hit). There, Activision became known as "The Shanghai Company" and the game was ported to every conceivable platform — from arcade to word processors. There were even some different versions of *Shanghai* which never made it to these shores.

The original *Shanghai* proved so popular with Japanese players that a sequel was needed to keep up with the demand. In 1989, *Shanghai II* was released for the arcade — it added new elements, including more layouts and additional tile sets. This inspired Activision game designers, and in 1990 *Shanghai II: Dragon's Eye* was born. Not only did the game now include twelve new layouts to correspond to the twelve signs of the Chinese Zodiac, it added seven colorful tile sets and a whole new addiction: Dragon's Eye — a two-player game which obligingly

took the role of your opponent if you didn't have a partner handy. In the U.S., *Shanghai II: Dragon's Eye* was released on DOS, Windows, Macintosh, Super Nintendo Entertainment System and Sega Genesis.

*Shanghai II: Dragon's Eye*, true to the Shanghai legacy, continued to take Japan by storm (under the name *Super Shanghai*) and in 1993 yet another sequel blazed a trail through the skies of the Rising Sun. *Shanghai III* incorporated arcade-style action into the scheme of things with even more exciting two-player modes. While this was going on, Activision game designers were hard at work designing three new games for *Shanghai: Triple-Threat* and... the upcoming multimedia version — *Shanghai: Great Moments*, featuring yet another new game and a Hollywood actress as your Shanghai hostess, who introduces the game and offers hints at your request. Stay tuned!

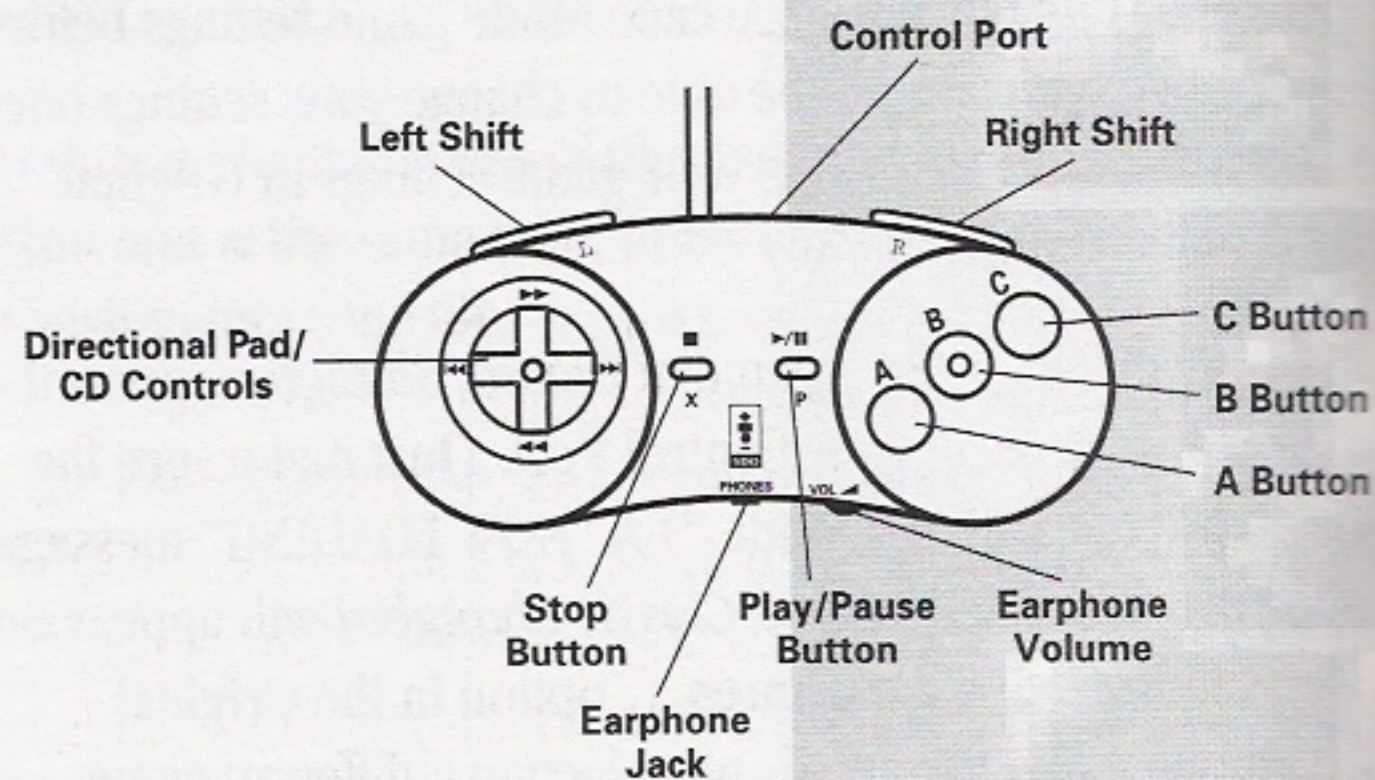
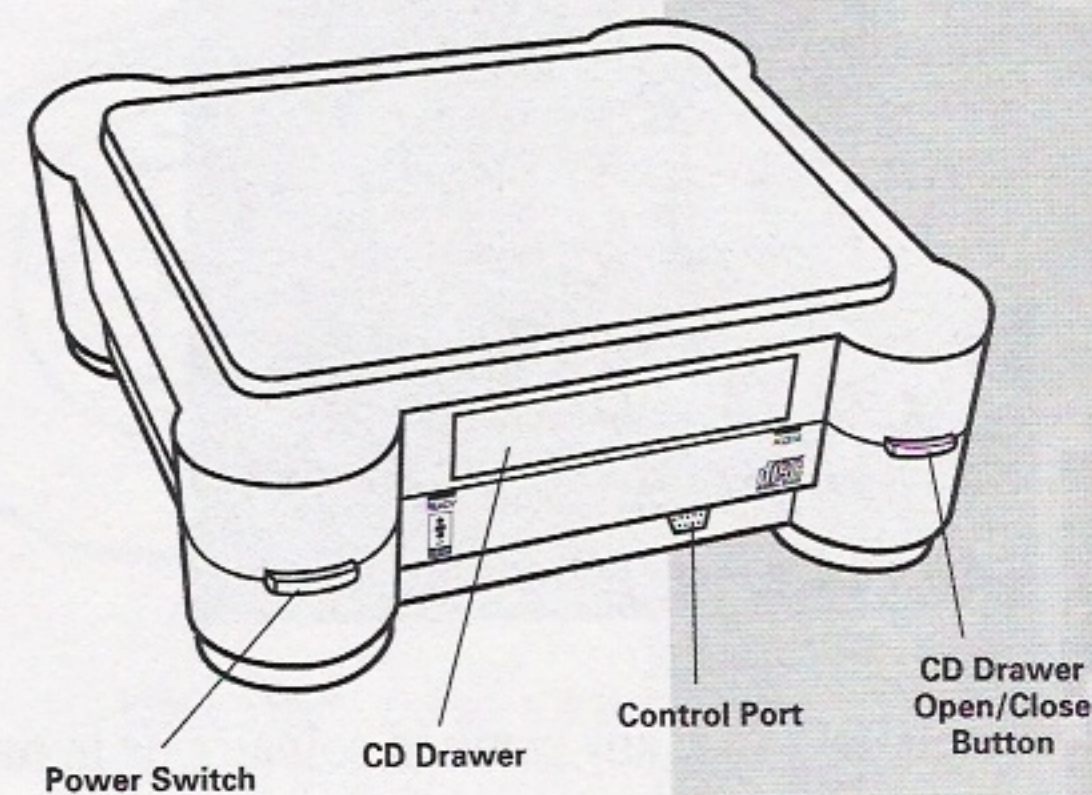



# GETTING STARTED

1. Press the **Power Switch** on your 3DO™ Interactive Multiplayer™ system to turn the power ON. Then, press the **CD Drawer Open/Close Button** to open the CD Drawer.
2. Place the *Shanghai: Triple-Threat* CD in the CD Drawer and press the **CD Drawer Open/Close Button** to close the drawer.
3. Your 3DO™ Interactive Multiplayer™ system will automatically load *Shanghai: Triple-Threat*. After a few seconds, the *Shanghai: Triple-Threat* title screen will appear. (You can skip the preview and bring up the title screen by pressing the **A Button** on your Control Port.)
4. The following screen will appear:



**ORIGINAL MODE**- Play any game in solitaire or in two-player "pandamonium."

**ARCADE MODE**- Play any game in timed arcade-style action — in one-player or in two-player "pandamonium."

**CONFIG**- Configure your Arcade Mode game settings before playing a game; you will not be able to change your settings once a game has begun. (To change your game settings in Original Mode, use the Options menu.)

To immediately begin a game of *Classic Shanghai*, press the **Play/Pause Button** on your Control Port. (Just make sure the cursor is next to "Original Mode.") A "NOW LOADING" message will appear on your screen and *Classic Shanghai* will appear on your screen. Note: See the **Games...** option in the Original Mode Options menu for details on selecting a different game from the *Classic Shanghai* screen.

# USING THE CONTROL PORT

To remove a pair of tiles during the game, simply select the two matching tiles you want. To select a tile: use the **Directional Pad** (D-Pad) on the Control Port to move the cursor to the first tile, and press the **A Button**. If it's free to be removed, it will become highlighted. Select the matching tile to remove the pair. If you change your mind about selecting a tile, just press the **B Button** and it will become unhighlighted. If you choose a blocked tile or a tile that does not match an already highlighted tile, it will not be highlighted and the message "You can't take that tile" will appear.

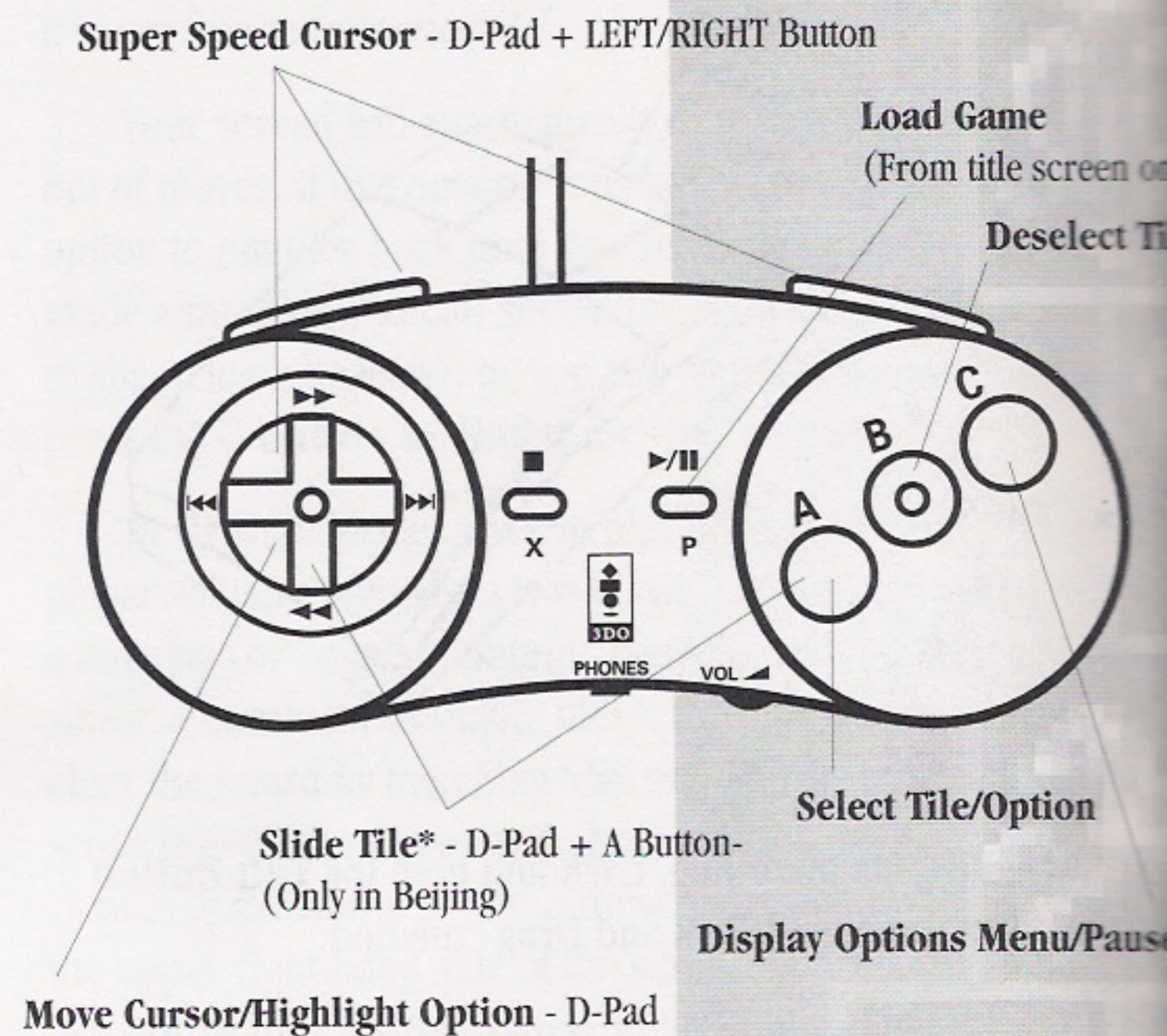

\* To slide a tile or a series of tiles in Beijing, hold down the **A Button** and at the same time, press the **D-Pad** in the direction you wish to move the tile.



## USING THE 3DO MOUSE

You can play a game with a 3DO Mouse instead of the Control Port in a one-player game, or along with the Control Port in a two-player game. To use the mouse in a two-player game, just connect it to your Control Port and use the 3DO Mouse as the Player Two controller.

Note: Use the **Left**, **Center** and **Right Buttons** on the mouse in place of all references to the **A**, **B** and **C Buttons** in this manual.

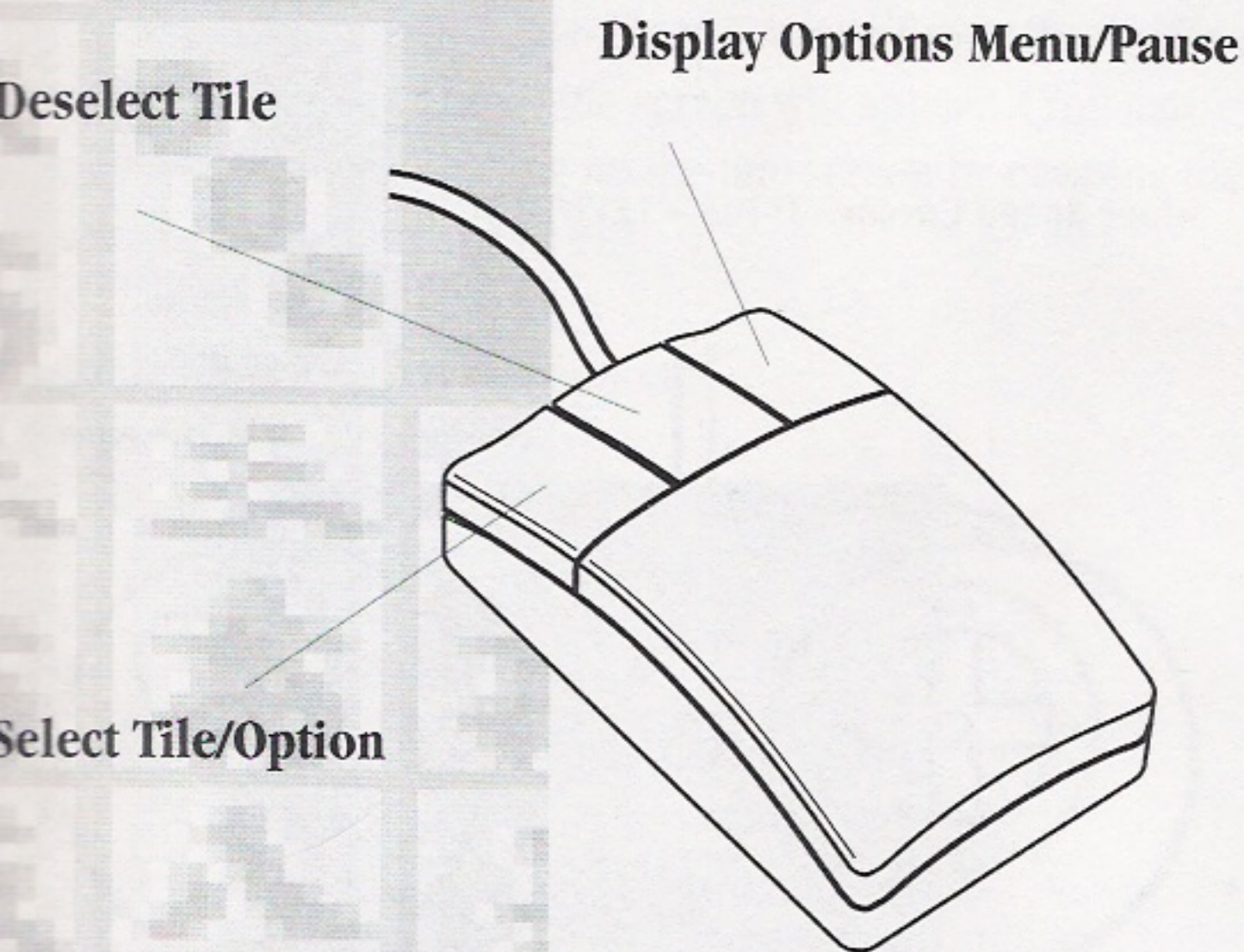

Note: To slide a tile in Beijing, click and hold the **Left Button** to use the normal mouse "Click and Drag" method.

## PLAYING THE GAMES

### Classic Shanghai

#### Rules

*Classic Shanghai* is a game of strategy, memory and luck. Each game begins with 144 tiles, arranged in one of ten different layouts in Original Mode, or 30 in Arcade Mode. The object is to remove all the tiles from the layout, one pair at a time. To remove a pair, the tiles must both match and be "free" at the same time. A tile is considered free if no other tile is on top of it and it can slide out to the left, to the right, or in both directions. If a tile can only slide toward the top or the bottom of the layout, it is not free to be removed.

Your screen will automatically alert you when you have run out of moves. If this occurs, you can use the "Back one move" option to put tiles back until you get to the point where you made a mistake; you can shuffle the remaining tiles (and resort to shameless cheating), or you can start a new game — just press the **C Button** to display the Options menu.

In Original Mode, you can play *Classic Shanghai* in a one-player solitaire game or a two-player game of cooperative-style gameplay (or "pandamonium" because both players scramble simultaneously for available tiles). In either case, the object is to clear the board by matching tiles one pair at a time. While no score is kept, the screen will show you how many tiles still remain in the layout as you remove pairs. So, if you see "32" on the upper right-hand side of the screen, you will know that there are still 32 tiles (sixteen pairs) to be removed.

Arcade Mode *Classic Shanghai* features a 30-stage timed tournament in which the object of the game is the same as *Classic Shanghai*, intensified by the added element of time. Points are earned each time a pair is removed and each score is added to an overall tournament score as you advance through progressively difficult games of *Classic Shanghai*. High-point tiles are valued at 300 points per match, while low-point tiles are worth 100 points when matched (see *Matching the Tiles*).



## Strategy and Hints

- Concentrate your efforts on long rows and tall stacks.
- Plan ahead as many moves as you can.
- If all four of a tile are available, remove them all to unclutter the field.
- Identify as many matching pairs as possible. Check for tiles that need to be unblocked.
- Look for triples, and choose carefully which pair you remove. Leave the one that's blocking the least important tiles.
- Concentrate on removing tiles that will unblock the most tiles.
- Can't select a tile? Maybe another tile is already highlighted — press the **B Button** and try again.

## Matching the Tiles

The tile sets are made up of groups of four identical tiles which can be removed as two matching pairs. In each tile set, there are two groups of four unique tiles which can be paired with any other similar (but not necessarily identical) tile in its group.

In the *Shanghai: Triple-Threat* games that are scored (Original Mode Beijing, and all Arcade Mode games except Golden Tile), different tiles will contribute different point values when matched. The tile sets are divided into high-point tiles and low-point tiles. Removing a pair of high-point tiles add a higher number of points to your game score than low-point tiles upon making a match. (Note: See each game's play rules for specific scoring rules.)

## The Mah-Jongg Tile Set

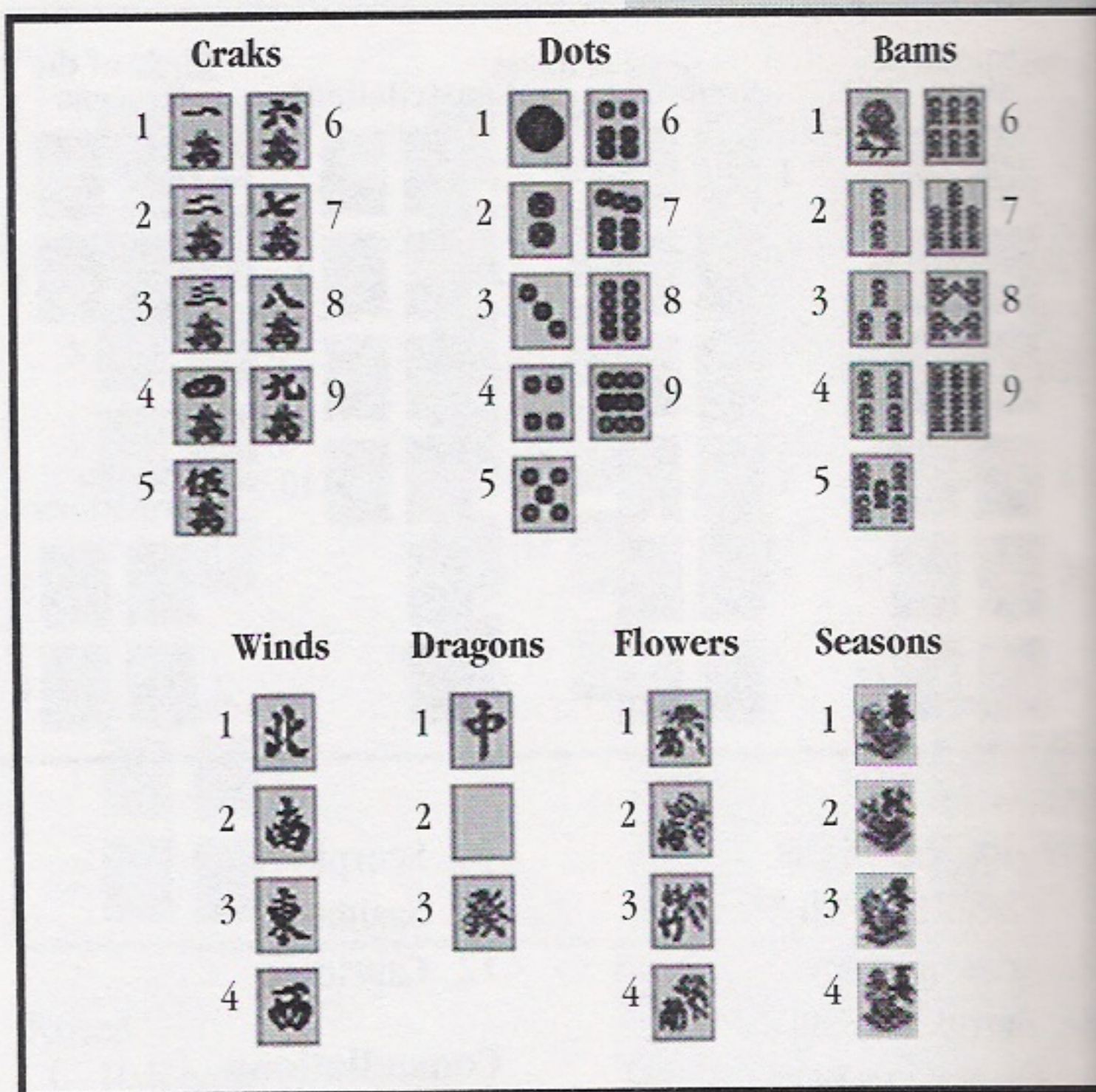

Only 2's through 8's in Craks, Dots and Bams are low-point tiles. All other tiles are high-point tiles.

### Winds

1. North Wind
2. South Wind
3. East Wind
4. West Wind

### Dragons

1. Red Dragon
2. White Dragon (Blank)
3. Green Dragon

### Seasons \*

1. Spring
2. Autumn
3. Winter
4. Summer

### Flowers \*

1. Chrysanthemum
2. Plum
3. Bamboo
4. Orchid

\* Tiles within a special group match other tiles within the group.



## The Zodiac Tile Set

Astrological Signs	Symbols	Constellations	Birds of the Heavens	Stellar Formations
1	1	1	1	1
2	2	2	2	2
3	3	3	3	3
4	4	4	4	4
5	5	5		
6	6	6		
7	7			
8	8			
9	9			
10	10			
11	11			
12	12			

### Astrological Signs

- Pisces the Fish \*\*
- Aries the Ram
- Taurus the Bull
- Gemini the Twins
- Cancer the Crab
- Leo the Lion
- Virgo the Virgin
- Libra the Balance
- Aquarius the Water Bearer \*\*
- Scorpio the Scorpion
- Sagittarius the Archer
- Capricorn the Goat

### Symbols

- Pisces \*\*
- Aries
- Taurus
- Gemini
- Cancer
- Leo
- Virgo
- Libra
- Aquarius \*\*

### Constellations

- 10. Scorpio
  - 11. Sagittarius
  - 12. Capricorn
- ### Constellations
- 1. Lyra the Lyre \*\*
  - 2. Hydra
  - 3. Crater \*\*
  - 4. Hercules \*\*
  - 5. Orion the Hunter \*\*
  - 6. Pegasus \*\*
  - 7. Monoceros \*\*
  - 8. Camelopardalis \*\*
  - 9. Ursa Major \*\*
  - 10. Canis Major \*\*

### Birds of the Heavens \*

- 1. Aquila the Eagle \*\*
- 2. The Phoenix \*\*
- 3. Cygnus the Swan \*\*
- 4. Grus \*\*

### Stellar Formations \*

- 1. Little Dipper \*\*
- 2. Orion \*\*
- 3. Cassiopeia \*\*
- 4. Southern Cross \*\*

## The Music Tile Set

Notes	Musical Signs	Instruments	Strings
1	1	1	1
2	2	2	2
3	3	3	3
4	4	4	4
5	5	5	
6	6	6	
7	7	7	
8	8		
9	9		
	10		
	11		
	12		
	13		
	14		
	15		
	16		
	17		

### Notes

- 1. Half note \*\*
- 2. Double sixteenth
- 3. Whole note
- 4. Double eighth note
- 5. 3/8ths note \*\*
- 6. Quarter note \*\*
- 7. 3/16ths note \*\*
- 8. Eighth note \*\*
- 9. 3/32nds note \*\*

### Musical Signs

- 1. F-clef
- 2. Repeat measure
- 3. G-clef
- 4. C-clef
- 5. Dal segno
- 6. Fermata
- 7. Left repeat
- 8. Right repeat
- 9. Pianoforte
- 10. Forte
- 11. Common time
- 12. Sharp

### Instruments

- 13. Natural
- 14. Flat
- 15. Double flat
- 16. Eighth rest
- 17. Quarter rest

### Instruments

- 1. Synthesizer \*\*
- 2. Mouth organ \*\*
- 3. Piano \*\*
- 4. Tuba \*\*
- 5. Bell \*\*
- 6. Trumpet \*\*
- 7. Maracas \*\*

### Percussion \*

- 1. Timpani \*\*
- 2. Tsuzumi (Japanese drum) \*\*
- 3. Gong \*\*
- 4. Drums \*\*

### Strings \*

- 1. Violin \*\*
- 2. Electric guitar \*\*
- 3. Bass guitar \*\*
- 4. Mandolin \*\*

Tiles within a special group match other tiles within the group.  
 \* Denotes a tile with a high-point value.

\* Tiles within a special group match other tiles within the group.  
 \*\* Denotes a tile with a high-point value.



# The Great Wall

## Rules

The *Great Wall* is played by pairing matching tiles, removing them exactly as in *Classic Shanghai*. The goal of *The Great Wall* is to clear all the “bricks” of the wall. The difference and the challenge is that you must now consider the effect of gravity in every move you make because higher tiles will fall when they are no longer supported by the tiles beneath. This unavoidable gravitational pull completely alters the arrangement of tiles and the strategy that you must employ in order to win.

Another important force involved in *The Great Wall* is magnetism. In alternate rows, tiles must be spaced a half space off from the rows just above and below. So, if a tile falls to a lower row (after a lower tile has been removed) and leaves a half-space opening between another tile, magnetism will enforce this rule and cause the tile to slide over and close the gap. This will occur regardless of there being a neighboring tile which presents yet another consideration in removing tiles in higher rows.

At any time that there are no more moves, the game will end. In Original Mode, you then have the option of putting back moves or shuffling remaining tiles as in *Classic Shanghai* by using the Options menu.

Just like in Arcade Mode Shanghai, points are earned in an Arcade Mode game of *The Great Wall* each time a pair is removed. Each game's score is added to an overall tournament score as you advance through progressively difficult games of *Classic Shanghai*. High-point tiles are valued at 300 points per match, while low-point tiles are worth 100 points when matched.

## Strategy and Hints

The strategy you learned for *Classic Shanghai* won't work here — you can't count on the game situation to remain the same after removing a pair. So, when looking at future moves, consider which tiles will be moving.

- Keep your eye on the bottom row — don't let higher tiles fall to this row or into the narrow corners where you won't be able to get them out.
- Can't select a tile? Maybe another tile is already highlighted — press the **B Button** and try again.

# Beijing

## Rules

*Beijing* combines traditional Shanghai gameplay with the sliding action of pocket-sized, sliding-tile puzzles. You can make matches by sliding a tile next to its matching tile, or by selecting matching tiles according to Classic Shanghai rules. To begin, the tiles are placed side-by-side in a single-level layout at random. This inevitably results in the adjacent placement of matching tiles, which are immediately removed before gameplay begins and points awarded to the player. When these initial matches are removed, the result is a layout with double-tile-sized holes throughout.

Gameplay consists of removing pairs of tiles in two different ways. The first way is by using the traditional Shanghai method — select a “free” tile (unblocked on left or right), then select its unblocked (“free”) matching tile. The second way is to slide a tile or a series of tiles horizontally or vertically, pushing any tiles in the way in the same direction, in an attempt to place a tile next to its matching tile. The tiles will only remain where the slide placed them if the result of the slide was a match.

The object of *Beijing* is to gain the highest possible score while clearing all the tiles from the screen. You can clear the board as in *Classic Shanghai*, but clearing the screen in the method used in *Classic Shanghai* will guarantee the lowest score. If a pair is removed as a non-sliding Classic Shanghai move, low-point tiles are valued at 100 points per match, while high-point tiles are worth 300 points a pair. However, if the same pair is removed by a sliding move, low-point tiles are valued at 300 points per match, while high-point tiles are worth 600 points a match.

To improve your scoring potential, you can position the tiles strategically to make more than one match at once. If more than one match were to result from one slide move, the pairs would be removed and the points would be determined not only by their high- and low-point values, but also by the number of pairs removed with one slide. For example, if two pairs of 300-point tiles were matched with one slide, the total point value would be  $300 + (300 \times 2) = 900$ . If three pairs of low-point tiles were matched with one slide, the total point value would be  $300 + (300 \times 2) + (300 \times 3) = 1800$ , and so on...



You use the “click and drag” method to push tiles — press and hold the **A Button** to select the tile you want to use as the push point, then press the **D-Pad** in the desired direction at the same time while still holding the **A Button** in. This causes the tiles in the indicated direction to be pushed. You can only push in that direction if there is a gap in the row or column. If you try to slide a row or column that does not result in a match, the move will be disallowed.

Since Original Mode allows you to play *Beijing* in unlimited time gameplay, you can take the time to perfect your Beijing strategy in preparation for the competitive, timed gameplay of Arcade Mode. In Arcade Mode *Beijing*, the object of the game is the same, except that you are now limited to making the highest-scoring pairs within the selected time limit and can increase the challenge by playing against an opponent.

### Strategy and Hints

- Think ahead — one move might set up future moves.
  - Don't be in a rush to remove a pair — study the board to identify possible multiple pair moves (like three of a kind), which result in even higher scores.
- If a potential move isn't possible because there are too many tiles in the row or column, look to see if you can get rid of some tiles using the normal Classic Shanghai rules.
- Watch the layout boundary for hints. If the boundary is white, you know that there are still high-scoring slide-moves available. But when the border turns red, no high-scoring moves are available. However, it is often possible to turn the border white again by making a smart click move.
  - *Beijing* is a very challenging game — if you're going to play in Arcade Mode, you might want to preset the Time Bar to a higher setting.
  - Can't select or slide a tile? Maybe another tile is already highlighted — press the **B Button** and try again.
  - Compound slide-moves (ie. sliding tiles left then up) are not possible, but in a two-player game, both players can bring tiles together cooperatively and share in the points.

## Golden Tile

### Rules

The object of *Golden Tile* is to race to uncover and remove the golden tile buried deep in a layout — one of two side-by-side layouts. Each similar layout hides its own golden tile in a different arrangement of tiles. To uncover the hidden tile, two players race to remove pairs of tiles using Classic Shanghai rules. Each player is assigned a layout to “mine,” and the race to uncover the golden tile in their particular layouts begins. But, the slight twisting of these rules is what adds to the excitement. Though a player only wins when he/she uncovers and removes the golden tile in his/her assigned layout, there is nothing said about borrowing tiles from your opponent's layout. . .

While *Golden Tile* is not a scored game, it is a race — with the challenge being in the skill and the speed it takes to be the first to uncover and remove the golden tile. Although *Golden Tile* is intended to be a true race against another opponent, you might enjoy trying a one-player game in Arcade Mode, against the clock.

The screen will not show a score, since pairs in Golden Tile games are not removed for points. In Arcade Mode, the only numbers that will appear at the top of the screen represent the total number of “wins” for each player.

### Strategy and Hints

- Don't forget that while borrowing a tile from the other layout may help you, it also gets your opponent closer to uncovering his/her golden tile.
- Can't select a tile? Maybe another tile is already highlighted — press the **B Button** and try again.



# ORIGINAL MODE

In this mode you can play any of the four *Shanghai: Triple-Threat* games in the classic meditative tradition of Shanghai. Your games will not be timed, so that you may fully concentrate on perfecting your game strategies. Play a one-player game of solitaire or a two-player cooperative-style “pandamonium” game. In Original Mode, a wide range of options that are not available in Arcade Mode are available during your games (see *The Options Menu*).

To play a game in Original Mode from the title screen, use the **D-Pad** to move the cursor next to “ORIGINAL MODE” and press the **A Button** to select it. From Arcade Mode, press the **C Button** to pause the game and select “Original Mode.”

## The Options Menu

The Options menu allows you to change your game options and preferences any time during an Original Mode game. Bring up the Options menu on your screen (**C Button**), use the **D-Pad** to highlight the option you want to change, then press the **A Button** to select, toggle (on/off) or bring up that option’s menu selections.



## Arcade Mode

Exit Original Mode and play any game in timed arcade-style action (see *Arcade Mode*). Press the **A Button** to return to the title screen where you can start a new game in Arcade Mode.

## Preferences...

Customize your games to your liking. From the Options menu, highlight “Preferences...” and press the **A Button** to display the following menu. Once you have set your preferences, highlight “RESUME” (or press the **C Button**) and press the **A Button** to continue your game.

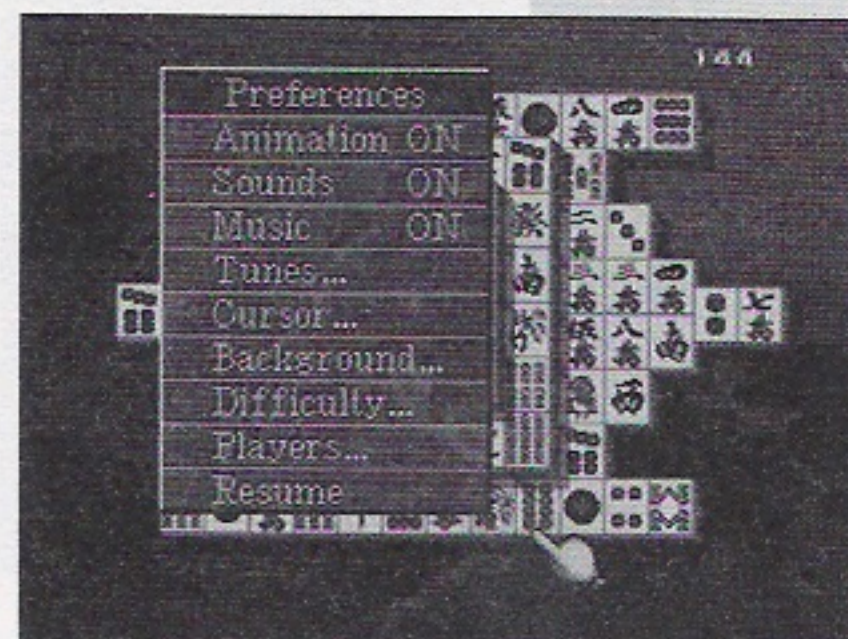

- **Animation** - Turn tile animations on or off. Use the **D-Pad** to highlight this preference, then press the **A Button**.
- **Sounds** - Play your games with sounds or no sounds. Press the **A Button** to toggle between ON or OFF.
- **Music** - Play music or turn music off when you play a game.
- **Tunes...** - Highlight this preference and press the **A Button** to display a list of tunes you can listen to while you play.
- **Cursor...** - Select one of three cursors; just press the **A Button** to display your options.
- **Background...** - Choose one of ten photographic backgrounds for your games.
- **Difficulty...** - Assume the knowledge of a range of Shanghai players — from Practice to Master. Note: Difficulty is determined by the way the tiles are arranged — so if difficulty is adjusted mid-game, nothing will happen until a new game is started.
- **Players...** - Play Original Mode games as one-player solitaire games or two-player cooperative games with a friend in “pandamonium”. Note: Golden Tile is still a competitive game, although you can try to play cooperatively.
- **Resume** - Select this option (or just press the **C Button**) to exit the Preferences menu and resume gameplay.



## Games...

This option allows you to play a “New game” of the one you just played (with tiles in a different pattern), replay the same game (with tiles in the same exact pattern) and “Try again,” or select a “Different game...” to play.

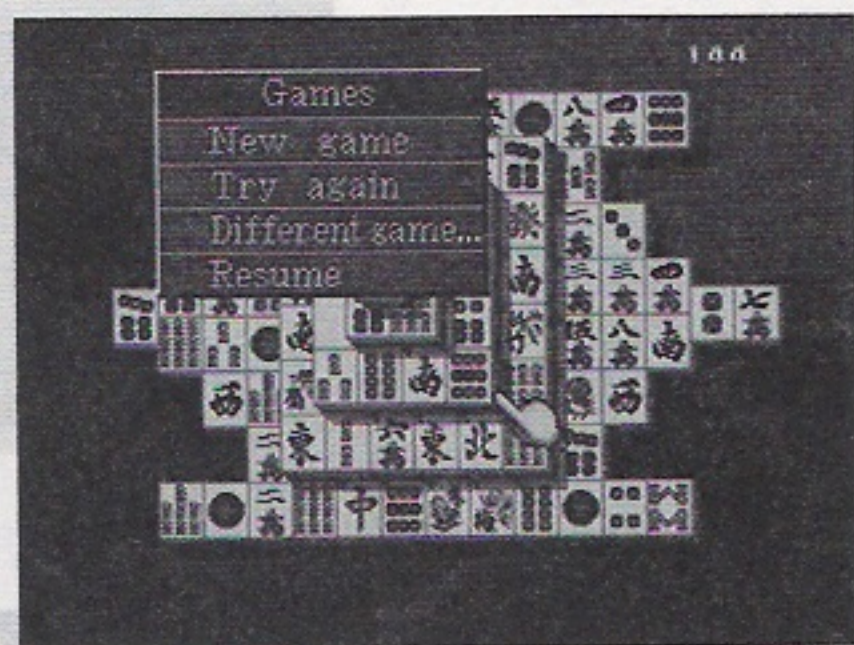

To play a different game, highlight the Different game... option and press the **A Button** to display the following menu:

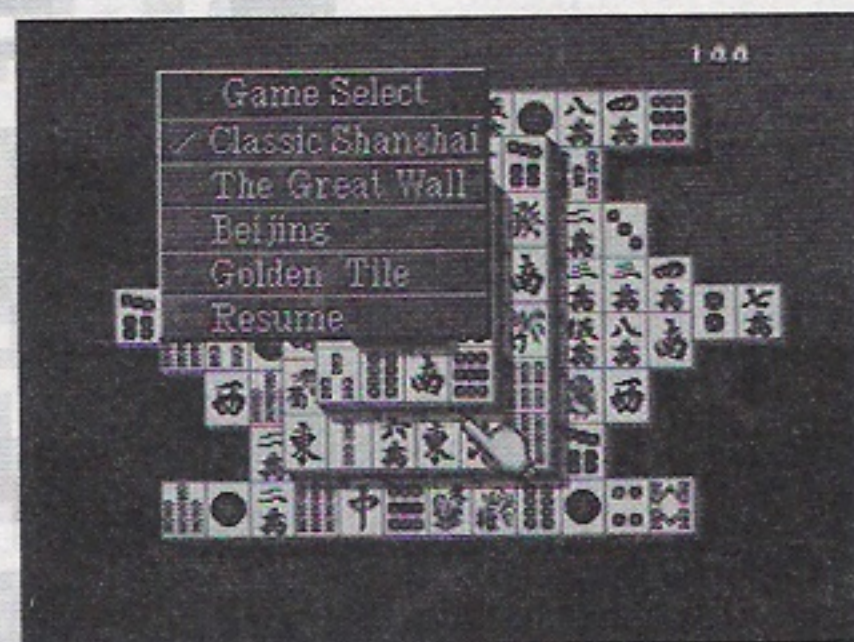

Use the **D-Pad** to highlight the game you want to play or highlight Resume and press the **A Button** (or just press the **C Button**) to exit the menu and resume gameplay.

## Tiles...

Play your games on the tile set of your choice. Choose one of three themed tile sets: Mah-Jongg, Zodiac or Music (as shown previously).

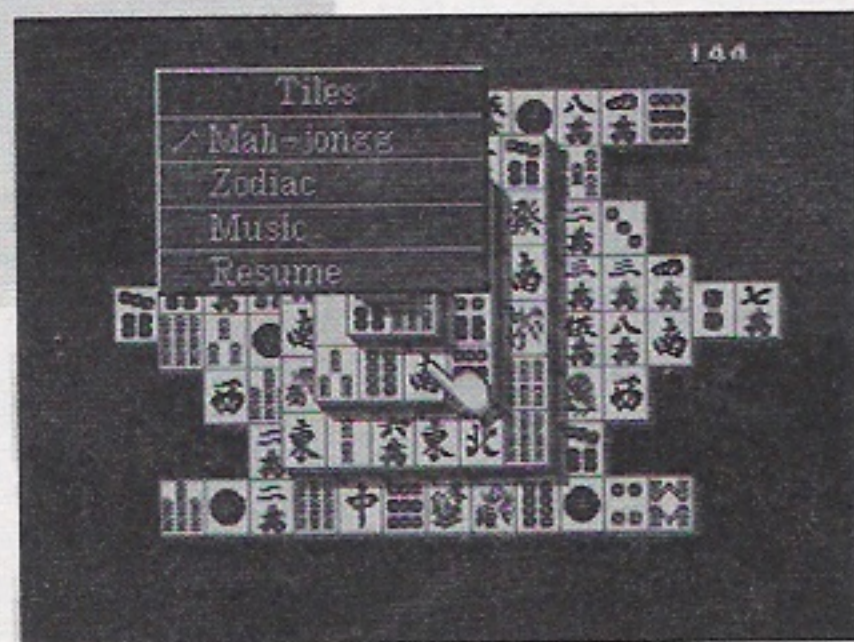

## Layouts...

Each game provides you with ten different layout options. Highlight a layout name and press the **A Button** to load your layout selection instantly.

## Help...

The Help option will give you these helpful options any time during the game:

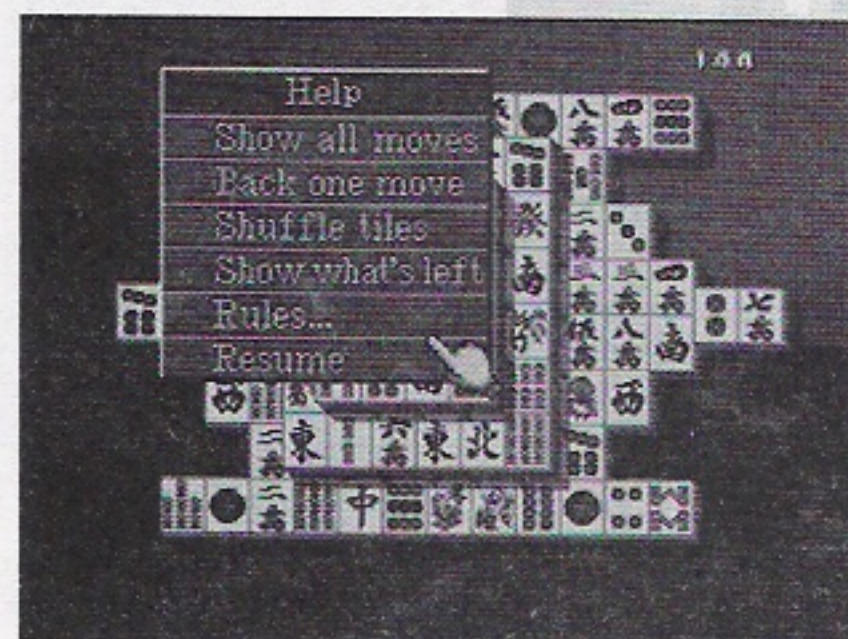

- If you're stumped, select “Show all moves” to see all the possible matches you can currently make.
- Choose “Back one move” to replace the last pair you removed, or even all the tiles — all the way back to the beginning of the game.
- You can also select “Shuffle tiles” if you aren't particularly satisfied with your current tile arrangement, and the tiles will be rearranged for you.
- “Show what's left” will temporarily stack all remaining tiles according to tile design (or group) so you can see whether all four of a tile are still on screen — an important aspect of strategy.
- If you need to brush up on your game rules, select “Rules...” for a brief explanation of the game you are currently in.

## Resume

Select this option (or just press the **C Button**) to exit the Options menu and resume your game.



# ARCADE MODE

The Arcade mode challenges you to a thirty-stage arcade-style tournament in which you can play by yourself in an attempt to beat the clock and top the high score, or head-to-head against an opponent. In Arcade Mode, points are earned each time a pair of tiles is removed. If you choose to play an arcade tournament, each score is added to an overall tournament score as you advance through progressively difficult stages of the game you selected. Unless, of course, you or your opponent “gets stuck” or runs out of time, in which case the score would automatically be reset to zero.

Before each stage, you will receive a password. Write down your password (being careful about 1's and l's and 0's and O's, etc.), and use it to continue your competition at a later time from the last stage you completed. Note: If you use a password to continue an arcade tournament, your score will be reset to zero.)



To play a game in Arcade Mode, (from the title screen) use the **D-Pad** to move the cursor next to “ARCADE MODE” and press the **A Button** to select it. From Original Mode, press the **C Button** to display the Options menu and select “Arcade Mode.”

Before you select Arcade Mode, you may want to configure your game settings to your liking. Be sure to make any configuration changes before you start a game; you can only access the Configuration menu before you begin an Arcade mode game (highlight “CONFIG” and press the **A Button**).

# The Configuration Menu

Use the **D-Pad Up/Down** to highlight the arcade game option you want to change, then press the **D-Pad Left/Right** to select your preferences. After setting your options, confirm the highlighted options on the Configuration screen, select “EXIT” and press the **A Button**.

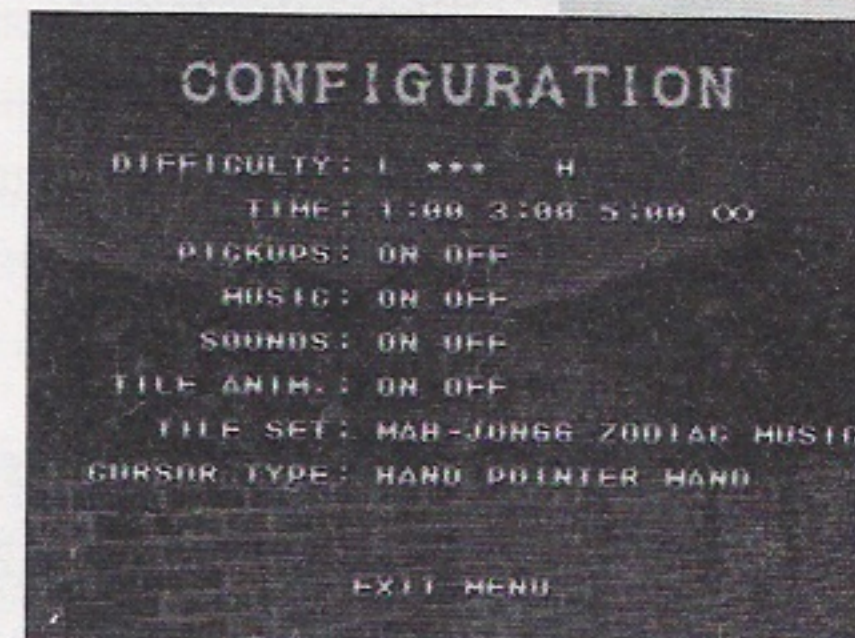

- **DIFFICULTY** - Set one of five levels of difficulty — from low to high. Each asterisk represents a level of difficulty, five asterisks being the highest level.
- **TIME** - Select a time bar of one, three, five minutes — or infinity.
- **PICKUPS** - Play your games with or without **Help** and **Back** pickups. (See *Arcade Mode Items*.)
- **MUSIC** - Turn game music on or off.
- **SOUNDS** - Set sound or no sound during gameplay.
- **TILE ANIM.** - Turn animations on or off.
- **TILE SET** - Choose one of three tile sets: Mah-Jongg, Zodiac or Music.
- **CURSOR TYPE**- Use one of three cursors: Hand, Pointer or Wand.
- **EXIT MENU** - Select this option to exit the Configuration screen and begin your arcade gameplay.

After you select your configuration options and exit back to the title screen, use the **D-Pad** to move your cursor to “ARCADE MODE,” and get ready for a *Triple-Threat Shanghai* challenge.



You will then have the option of playing a Classic Shanghai, Great Wall, Beijing or Golden Tile game in the Arcade Mode. Use your **D-Pad** to highlight the game you want to play and press the **A Button**.



Once you choose the game you want to play, select either a one-player game for a race against the clock, or a two-player game to go up against an opponent in “pandamonium.”

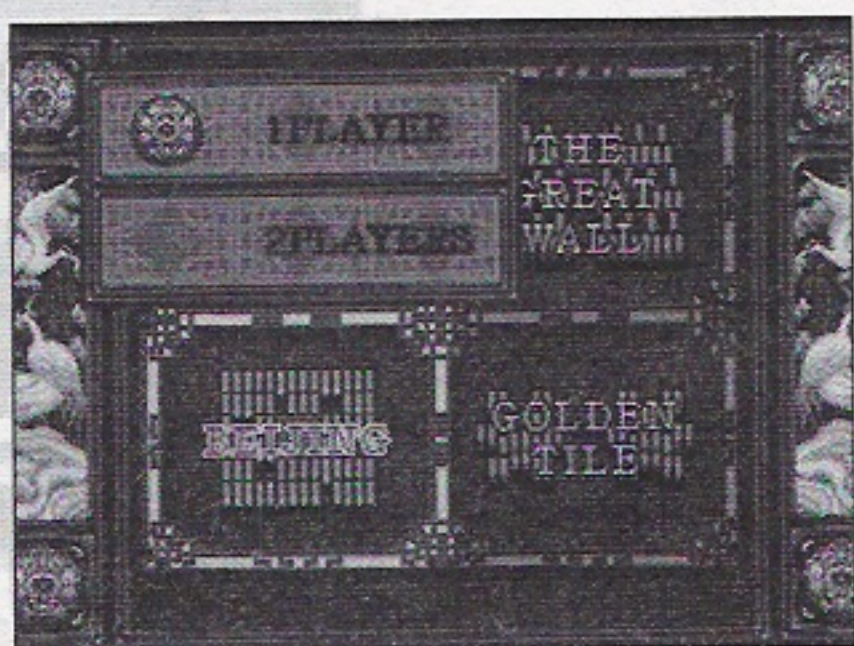

Then, select either “Start” to start from the beginning or continue your arcade tournament by selecting “Password.”



Before each Shanghai, Beijing and Great Wall game stage, you will see a map of the Great Wall of China and the challenging 30-stage journey your tournament will take you on. As you advance in your tournament, the map will mark the progress you have made in your journey along the Great Wall by highlighting the places you have successfully visited.

## Entering a Password

When you select “Password,” (after selecting a one- or two-player game in Arcade mode) use the **D-Pad** to highlight the first letter or number of your three-digit password, then press the **A Button** to enter it. Repeat this step to select the next two letters (or numbers) in your password, then highlight “END” to enter your password. If you make a mistake entering a digit, press the **B Button** to backspace. To exit the Password screen without entering a password, make sure the three password spaces are blank (using the **B Button** to backspace) and press the **B Button** again.



If you are having trouble entering a password, check to see that you wrote down the correct password digits. For example, a vertical line may actually be the letter “I” or the number “1” or even an exclamation point; while a circle may represent the letter “O,” the number “0” or the letters “D” or “Q.”

## Arcade Mode Items

To help you along in your arcade tournament, the Arcade Mode offers you a few items that you may or may not deem useful — depending on how much of a challenge you can handle...

**HELP** Help Pickup - You have three Help pickups available to you at the start of a game. If you can't seem to find a match, move your cursor to a Help box and press the **A Button** — and all the possible matches you can currently make will be highlighted.

**BACK** Back Pickup - At the beginning of a new game, you have three opportunities to undo a move. Select a Back Pickup and the last pair you removed will be replaced on your layout.





**Give Up** - The Give Up icon allows you to end a game when it becomes apparent that there is no way for you to win.



**Time Bar** - The Time Bar lets you know how much tile-matching time you have left. It will decrease in three minutes\* if you do nothing, but you can add to your remaining time every time you remove a pair.

\* This is the Time Bar default. See *The Configuration Menu* to select one minute, five minutes or infinity.

Note: Before starting a game, you can choose to play with or without Help and Back pickups. See the Configuration menu before you start an Arcade game.

## Strategy and Tips

- If you are playing in Arcade Mode and the clock is running, you might want to turn off the tile animations and sound effects.
- Don't be so quick to use Help pickups in two-player Arcade Mode, they may help your opponent more than they help you.
- Back Pickups may either help or annoy your opponent in two-player Arcade Mode games.

## The Bonus Level

After the first three stages, complete each third stage in an Arcade Mode tournament (except *Golden Tile*) and proceed to the Bonus Level where you will have the chance to earn points, Help Pickups and Back Pickups — and get the edge over an opponent.

The game is essentially *Classic Shanghai*, played with several tiles face-down. The object is to memorize the positions of the tiles and remove pairs to earn the bonus on each pair of tiles. The tiles only turn face-up when selected and only two tiles can be selected at one time. If the selected tiles do not match, the tiles will automatically turn face-down again. While there is no time limit, you are only allowed three incorrect tries. After your third incorrect attempt, the bonus round will end and you will only receive the bonuses on the tiles you succeeded in removing.

## Ranking

The top five highest scores will be ranked on the Arcade Mode ranking screen. To enter your initials: use the **D-Pad up/down** to scroll through the letters, press the **A Button** to select each initial (or the **B Button** to back-up) and press the **A Button** a third time to enter your three initials. Your initials will remain on the ranking screen until the 3DO system power is turned off.

## The Great Wall of China

Originally constructed as a colossal defense structure, The Great Wall has been built and rebuilt over a history of more than 2000 years. The construction of the Great Wall began under the Qin dynasty (221- 207 B.C.) and was undertaken thereafter on an enormous scale under later dynasties as recent as the Manchu dynasty (1644-1911). The building of the Wall was an uninterrupted process, just like the nation's cultural evolution. It is for this reason that the Wall has become a unique symbol of Chinese civilization.

The Great Wall consisted of one thousand formidable passes, almost ten thousand beacon towers for sending military signals, countless fortified castles, numerous ditches and broad avenues of traffic. The continuous structure of high walls was also supplemented by courier posts, ranches, storehouses, arsenals and ranches — all of which helped ensure logistic support for the defense system.

The Great Wall expands across the northern parts of China over a distance of thousands of kilometers with remains of its ancient version still found in present-day Soviet Union and People's Republic of Mongolia. If the lengths of all the sections constructed under various dynasties were to be added up, the accumulated total would be over 5000 kilometers (31,000 miles — about ten times the width of the contiguous United States).

The different sections of the Wall vary with the configuration of the terrain as well as with the time period in which each was constructed. Some sections are built of earth, others of stones or bricks while still others of layers of reeds and sand. Experts have calculated that if the amount of earth and stone involved in the construction of the Great Wall was used to build a wall one meter thick and five meters high, such a wall could circle the earth over a dozen times.



## The Thirty Stages of the Arcade Mode

Note: The names of the stages do not actually represent a linear travel along the wall; the stages are named for the places and objects pictured in the background of each stage.

1. Shanhaiguan
2. Badaling
3. Luoyang
4. BONUS STAGE (Badaling)
5. Guilin
6. Dragon Wall (Jiulong Bi)
7. BONUS STAGE (Badaling)
8. Shangfeimu (Xian Fei's Tomb)
9. Elephants (Min Xiao Ling, Nan Jing)
10. BONUS STAGE (Badaling)
11. Clay Army (Bing Ma Yong, Xian)
12. Guang Ling
13. BONUS STAGE (Badaling)
14. Laughing Buddha
15. Statue of Nirvana
16. BONUS STAGE (Badaling)
17. Da Guan
18. Huangputan
19. BONUS STAGE (Badaling)
20. Duo Wen Tower (Duowenta)
21. Beijing
22. BONUS STAGE (Badaling)
23. Shao Lin Temple
24. Statue of Guan Yu
25. BONUS STAGE (Badaling)
26. Hang Zhou
27. Forest of Steles (Beilin)
28. BONUS STAGE (Badaling)
29. Badaling
30. Jiayuguan

## CUSTOMER SERVICE

If you have any comments, questions or suggestions about *Shanghai: Triple-Threat* or any other Activision product, you can contact us at (310) 479-5644 between the hours of 9:00 a.m. and 5:00 p.m. Pacific Time Monday through Friday, except holidays. Or contact a customer service representative through the following on-line services:

### Activision BBS: (310) 479-1335

- Available 24 hours a day
- Up to 14,400 Baud
- Settings: 8 Bits, No Parity, 1 Stop Bit (8, N, 1)

**CompuServe:** 76004,2122 or [GO GAMEPUB] in the Game Publishers Forum B

**Prodigy:** ACTI10B

**Genie:** ACTIVISION

**America OnLine:** MEDIAJAKE or use keyword "ACTIVISION" to locate the Activision forum.

**Internet:** support@activision.com

### For customer service in Europe contact:

Activision U.K. Limited  
Long Island House, 3A  
1/4 Warple Way  
London, W3 0RQ  
United Kingdom  
(44) 081 742 9400



# CREDITS

Producer . . . . . Tom Sloper  
Associate Producer . . . . . Lewis Peterson  
Production Coordinator . . . . . Dustin Sorenson  
Game Designers:  
Classic Shanghai . . . . . Brodie Lockard  
The Great Wall . . . . . Tom Sloper and John Spinale  
Beijing . . . . . Tom Sloper and Peter Doctorow  
Golden Tile . . . . . Success Corp. and Tom Sloper  
Director of Quality Assurance . . . . . Jon Doellstedt  
Lead Tester . . . . . Andrew Held  
Testers . . . . . Chuck Bonini, Abe Heward,  
Seiken Nakama, Kenny Ramirez,  
and Mike Schneider.  
Documentation Manager . . . . . Michael Rivera  
Manual Writer . . . . . Veronica Milito  
Package Designer . . . . . Cindy Whitlock

## Special Thanks to:

Bill Swartz, Mika Kawamura, Alan Gershenfeld, Brian G. Kelly, Satoshi Honda, Jun Hashimoto, Brian Gilmer, Todd Sitrin, Takato Yoshinari, Kazutoshi Yashiki, and the Success Corp. staff

Activision and Shanghai are registered trademarks of Activision, Inc., and Shanghai: Triple-Threat is a trademark of Activision, Inc. Other product or brand names may be trademarks or registered trademarks of their respective owners.

© 1994 Activision Inc. All rights reserved.

Source code for 3DO System designed by Electronic Arts Victor Inc.

Code © 1994 Success Corp.

Photographs by JTB Photo © 1994

3DO and the 3DO logos are trademarks of The 3DO Company

THE 3DO COMPANY SHALL NOT BE LIABLE TO THE END USER FOR ANY LOSS OF DATA, LOST PROFITS, COST OF SUBSTITUTE GOODS OR OTHER CONSEQUENTIAL, INCIDENTAL, SPECIAL, PUNITIVE, OR OTHER DAMAGES OF ANY KIND ARISING OUT OF THE USE OF OR INABILITY TO USE THE SOFTWARE.

THE 3DO COMPANY MAKES NO WARRANTIES, EXPRESS IMPLIED OR STATUTORY, REGARDING THE SOFTWARE, INCLUDING WITHOUT LIMITATION THE IMPLIED WARRANTIES OF MERCHANTABILITY AND FITNESS FOR ANY PARTICULAR PURPOSE, OR ANY EQUIVALENT WARRANTIES UNDER THE LAWS OF ANY JURISDICTION.

DO NOT USE A FRONT OR REAR PROJECTION TELEVISION WITH THIS PRODUCT. YOUR PROJECTION TELEVISION SCREEN MAY BE PERMANENTLY DAMAGED IF STATIONARY SCENES OR PATTERNS ARE PLAYED ON YOUR PROJECTION TELEVISION. SIMILAR DAMAGE MAY OCCUR IF YOU PLACE THIS PRODUCT ON HOLD OR PAUSE. IF YOU USE YOUR PROJECTION TELEVISION WITH THIS PRODUCT, NEITHER THE 3DO COMPANY NOR ACTIVISION WILL BE LIABLE FOR ANY RESULTING DAMAGE. THIS SITUATION IS NOT CAUSED BY A DEFECT IN THIS PRODUCT OR THE 3DO SYSTEM; OTHER FIXED OR REPETITIVE IMAGES MAY CAUSE SIMILAR DAMAGE TO A PROJECTION TELEVISION. PLEASE CONTACT YOUR TV MANUFACTURER FOR FURTHER INFORMATION.

THE EXECUTION OF SOFTWARE WITH THE 3DO SYSTEM INVOLVES THE USE OF PATENT RIGHTS, GRANTED OR APPLIED FOR, IN CERTAIN COUNTRIES. A PURCHASER OF THE 3DO SYSTEM IS LICENSED TO USE SUCH PATENT RIGHTS WITH SOFTWARE LICENSED BY THE 3DO COMPANY. NO LICENSE, IMPLIED OR OTHERWISE, IS GRANTED FOR THE EXECUTION OF OTHER SOFTWARE.