

ASTRO FIGHTER

Gremlin[®]/SEGA[®]

MANUAL PART NO. 420-0410
or
420-0411

OWNER'S MANUAL

ASTRO FIGHTER
OPERATING INSTRUCTIONS
AND
SERVICE MANUAL

INTRODUCTION . . .

This is an electronic game that makes extensive use of digital integrated circuitry and television monitor circuitry. This manual assumes the maintenance technician possesses a general knowledge of solid state circuitry microprocessor, TTL digital integrated circuitry and T.V. monitor concepts. Any individual **not** knowledgeable in these areas **should not** attempt repair of the electronic portion of this game. **It should be noted that any attempt to repair the game in the field without the express consent of the factory will immediately void the warranty!!!**

IMPORTANT NOTES . . .

An important service note is posted in this game and is repeated here for emphasis:

If at any time the T.V. screen shows a meaningless display or the game otherwise malfunctions, simply drop a coin into the coin mechanism. This should correct the problem. If not, the game requires service.

The circuitry in this game has been arranged so that the insertion of a quarter through the coin mechanism will reset the restart in the system. This clears up temporary problems caused by power line disturbances, static, etc.

SERVICE TECHNICIAN NOTE:

The system reset circuitry described above requires that the coin counter is attached to the system. If there is a coin counter problem and no replacement is available, the game will function properly if a 10K Ohm resistor is connected across the coin counter input pins to the video logic board.

ALSO . . .

Never replace any components with anything other than exact replacement parts. (See Parts List located on Service Schematics.)

Never remove circuit boards/connections while power is on.

Do Not replace the fuse with anything other than the proper value. A blown fuse indicates an overload condition within the game. Replacing the fuse with a higher value can cause severe damage to internal components if an overload occurs.

Always consult the manual before attempting repairs.

Correspondence regarding this game should be addressed to:

GREMLIN INDUSTRIES, INC.
8401 Aero Drive
San Diego, California 92123
(714) 277-8700

REPACKAGING INSTRUCTIONS . . .

Arcade
25 1/4" W x 67" H x 28" D
64.77cm W x 170.18cm H x 71.12cm D
290 lbs./132 kg.

Arcade Version

1. Carefully lay game on its side.
2. Attach pallet with **four** 5/16" - 18 x 1-3/4" bolts, as shown.
3. See Final Reccrating Instructions, below.

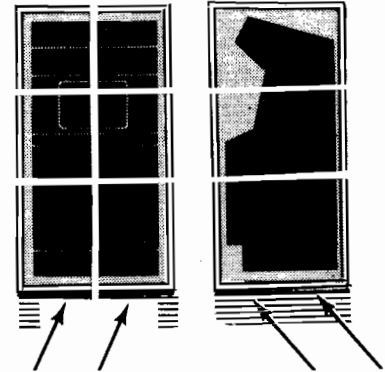

Mini-Video Version

1. Place game upright inside bottom cover.
2. Slide cover over game. Add protective packing material.
3. Place top cover over side cover.
4. See Final Reccrating Instructions, below.

MiniVideo
22" H x 21" W x 20" D
55.88cm H x 53.34cm W x 50.8cm D
80 lbs./36 kg.

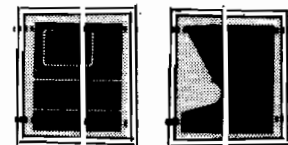

Cocktail Version

1. Place game inside carton.
2. Add protective packing material.
3. Place inside protective top cover over unit.
4. Close flaps and secure with shipping tape.
5. See Final Reccrating Instructions, below.

Cocktail
22" W x 34" L x 24 1/4" H
55.88cm W x 93.98cm L x 62.23cm H
80 lb./36 kg.



FINAL RECCRATING INSTRUCTIONS . . .

Place game upright. Tape down game keys. Then, crate the game using appropriate shock-absorbent packing material. Include packing on edges of game. **Secure package with strapping.**

Note . . . If the game is to be shipped to Gremlin Industries for service or repair, attach a tag identifying the distributor and indicate the service or repair to be done. Include the full serial number of the game.

All items must be shipped prepaid.

GAME CONCEPT...

ASTRO FIGHTER is a 1 or 2 player game of space adventure. Two players may take turns, competing for high score. The player's warship faces meteor showers and four lines of enemy defense forces in an effort to reach THE MASTER and destroy it. Besides the challenges to fighting ability, the player's warship has an expendable supply of fuel that must last through the fight with THE MASTER. Two player controls are provided: a joystick enables the player to maneuver his warship from side to side; and a missile firing button.

The play begins with your warship at the bottom of the screen facing a barrage of yellow meteors that will destroy your warship, if hit. All action appears from the top of the screen and descends to the bottom throughout the game.

You are given a full supply of fuel in the beginning of play. This supply will steadily be consumed as you play and you must defeat THE MASTER before you can refuel. You will want to watch this gauge carefully throughout the game; a blue line will show your present fuel condition at all times.

After the initial meteor shower, you will face 11 enemy warships. They will appear in a pyramid formation with the wide row emerging from the top of the screen first. The enemy will move from side to side and is capable of firing not only straight ahead, but to its left and right. As you destroy the enemy ships, the action of the remainder is intensified.

If an enemy warship gets past you and reaches the bottom of the screen, regardless of how many previous warships, or formations, you have destroyed, the original group of defenders will reappear and your warship will be advanced one step closer to the enemy. Essentially, you will begin again, only closer, and you will have used precious fuel in the meantime.

After you have conquered the first formation of enemy warships, you will face a new formation of 12 warships, staggered six across and two deep.

After defeating the second formation, you will face a force of 12 warships that are not in a formation, but are randomly scattered in front of you.

Following the victory of having blasted away the third line of defenses, you will now face 15 enemy warships, five across and three deep, in your efforts to reach THE MASTER and defeat it. The vertical columns of this defense force will be varied in their distance to your warship.

If you succeed in defeating all 15 of the enemy warships, you are now ready to meet, and destroy, THE MASTER.

A pattern will emerge on the screen resembling a corridor that your warship is traveling along. The stars will become brighter and THE MASTER will appear. THE MASTER's body will expand and contract as it moves across the screen, back and forth, while firing vicious missiles at you. THE MASTER's missiles are random and may be fired in any direction.

THE MASTER can only be defeated by a direct hit in the eye. This is the only way you can destroy THE MASTER.

When you have destroyed THE MASTER, a fuel pipe will link-up with your warship and your supply will, again, be full. You are now ready for more combat in your efforts to, once again, seek and destroy THE MASTER. But, beware...the meteor showers and enemy action are now intensified and your challenge is more difficult.

Throughout the play, a watchful eye must be kept on your fuel gauge. If your supply is exhausted at any time before you destroy THE MASTER...your warship will explode!

Player 1 and player 2 scores are displayed at the top of the screen and the high score from past games will be displayed.

The operator may select the number of credits per coin. In addition, the operator may enable the one-player, or two-player switch, located inside the unit.

OPTIONS SELECT AND SOUND CONTROL ADJUSTMENTS

DIP Switch No.

- 1 Not Used
- 2 ON BONUS awarded for each row eliminated
OFF BONUS awarded after formation eliminated
- 3 ON No Replay
OFF Replay

4	OFF	ON	OFF	ON
5	OFF	OFF	ON	ON
		1COIN·1PLAY	2COIN·1PLAY	1COIN·2PLAY

6	OFF	OFF	ON	ON
7	OFF	ON	OFF	ON
	9 JUMP	7 JUMP	5 JUMP	3 JUMP

- 8 On Upright or Mini-Video model
OFF Cocktail or Slimline model

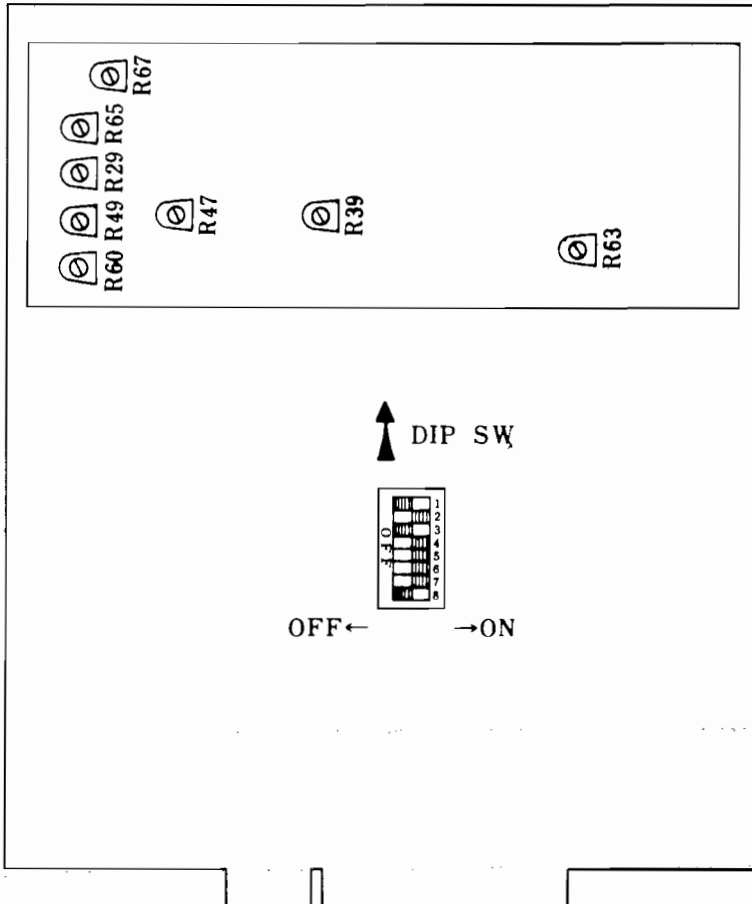

SOUND ADJUSTMENTS

- R29 Explosion Sound
- R39 Firing Sound
- R49 Master's Dying Sound
- R60 Firing Decay
- R63 Music Sound
- R65 High Pitch Tone Control
- R67 Main Volume Control
- R47 Factory Adjusted...Do Not Set

Cremitt Industries, Inc.
San Diego, California 92123

PARTS
LIST

TITLE ASSY HARNESS
MASTER A F

800-3010
DWG NO

SH 1
OF 3

A
REV

DRAWN MAHONEY

ENGR

CHECK *Sh...*

APPR

REVISION DESCRIPTION

DRAFT

CHECK

APPR

LTR DATE
A 2-6-80 RELEASED

2-8-80

J.M.

SP

SP

Gremlin Industries, Inc. San Diego, California 92123		PARTS LIST	TITLE TOP ASSEMBLY ASTRO FIGHTER, ENG WG	700-0006 DWG NO	SH 1 OF 2	A REV
USE WITH 700-0005 FOR FINAL ASSEMBLY		DRAWN Ron Krawiec	ENGR			
		CHECK <i>[Signature]</i>	APPR			
LTR	DATE	REVISION DESCRIPTION		DRAFT	CHECK	APPR
A	2-11-80	RELEASED		KAL	<i>[Signature]</i>	<i>[Signature]</i>
		REFER TO HEXAGON CALL-OUTS ON 700-0005 FOR				
		LOCATION OF PARTS LISTED HERE.				

CROWN INDUSTRIES, Inc. <small>SAN DIEGO, CALIFORNIA 92133</small>		PARTS LIST	TITLE ASSEMBLY CONTROL PNL ASTRO FIGHTER	800-3009 DWG NO	SH 1 OF 3	A REV
SHEET 3 IS "D" SIZE		DRAWN MANDNEY	ENGR			
		CHECK <i>S. J. Fay</i>	APPR			
LTR A	DATE 2-8-80	REVISION DESCRIPTION RELEASED	2-8-80	DRAFT J.M.	CHECK <i>S.J.F.</i>	APPR <i>S.J.F.</i>

Gremlin Industries, Inc. San Diego, California 92123		PARTS LIST	TITLE ASSY-GAME ASTRO FIGHTER COCKTAIL (ENGLISH)	DWG NO 700-0007	SH / OF 1 / 5	REV A
SHT 4, 5 ARE "D" SIZE		DRAWN Wymc... 2-12-80	ENGR			
		CHECK [Signature] 2-17-80	APPR			
LTR	DATE	REVISION DESCRIPTION		DRAFT	CHECK	APPR
A	2-19-80	RELEASED		WJB	[Signature]	[Signature]

Gremlin Industries, Inc. San Diego, California 92123		PARTS LIST		TITLE ASSY - GAME ASTRO FIGHTER COCKTAIL (ENGLISH)		700-0007		SH 2 OF 5		A REV	
ITEM NO	PART NO	QTY PER ASSY			DESCRIPTION	REF DES					
1	253-0141	2			GRAPHIC CONT PANEL						
2	253-0142	1			GRAPHIC GAME SELECT						
3	280-0075	6			NUT WIRE LG.						
4	420-0370	1			DECAL COIN ENTRY						
5	420-0371	1			DECAL COIN INFO						
6	420-0404	2			TABLE GRAPHIC						
7	420-0411				MANUAL ASTRO FIGHTER	(COCKTAIL)					
8	478-0001	1			THERMISTER						
9	560-0046	1			ISOLATION XFMR						
10	800-0072	1			ASSY POWER SUPPLY						
11	800-3022	1			ASSY MASTER HARNESS						
12	800-3023	1			ASSY POWER HARNESS						
13	800-3024	1			ASSY HARN VOL CONT						
14	800-3026	1			ASSY FUSE BLOCK						
15	800-3027	1			ASSY GROUND STRAP						
16	800-3028	1			ASSY EMI HARN						
17	807-0010	1			ASSY HARNESS SPEAKER						
18	834-0010	1			ASSY SPECIAL DUAL JAPAN						
19	834-5000	1			ASSY GAME ELECTRONICS	(SEGA)					
20	600-0001	1			CORD, LINE, 3 COND						
21		8			SCREW PHL. PN. HD. 6x1/2 SH. MTL						
22		6			SCREW PHI PN. HD. 8x1/2 SH MTL						

ITEM NO	PART NO	QTY PER ASSY	DESCRIPTION	REF DES
1	800-3026	1	ASSY FUSE BLOCK	
2	834-5000	1	ASSY GAME ELECTRONICS	
3	560-0046	1	ISOLATION XFMR	
4	800-3031	1	ASSY VOL CONT BLOCK	
5	250-0048	1	CLIP SWITCH	
6	800-0072	1	ASSY PWR SUPPLY DUAL	
7	478-0001	1	THERMISTOR	
8	253-0150	2	CONTROL PANEL GRAPHIC	
9	834-0013	1	SLIMLINE CABINET (NO ELECT)	
10	253-0151	1	GRAPHIC COIN INFO	
11	420-0421	2	TABLE GRAPHIC	
12	253-0149	1	GRAPHIC GAME SELECT	
13	252-0078	1	SUPPORT BLOCK REAR A/F UPRIGHT	
14	252-0079	1	SUPPORT BLOCK FRONT A/F UPRIGHT	
15	140-0047	1	GAME BASE, SLIMLINE	
16	252-0081	2	MTG. BLOCK	
17	252-0082	2	BLK STNDFF ISOLATION XFMR	
18	252-0083	3	PWR SUPPLY MTG. BLOCK	
19	280-0004	12	CLIP, WIRE HOLD DOWN	
20		4	#6 x 1/2" PAN HD. SHI. MTL. SCREW	
21		6	#8 x 1" FLAT HD. WOOD SCREW	
22		7	#8 x 1" PAN HD. SHI. MTL. SCREW	
23		3	#10 x 1 3/4" FLT. HD. WOOD SCREW	
24		2	#10 x 1/2" PAN HD. SHI. MTL. SCREW	
25		4	#8 FLAT WASHER	

Gremlin Industries, Inc. San Diego, California 92123		PARTS LIST	TITLE TOP ASSY. GAME, ASTRO FIGHTER SLIMLINE	700-0008 DWG NO	SH 1 OF 6	A REV
SHTS. 4-6 ARE "D" SIZE		DRAWN MAHDNEY	ENGR			
		CHECK <i>[Signature]</i>	APPR			
LTR	DATE	REVISION DESCRIPTION		DRAFT	CHECK	APPR
A	3-3-80	RELEASED		J.M.	<i>[Signature]</i>	<i>[Signature]</i>

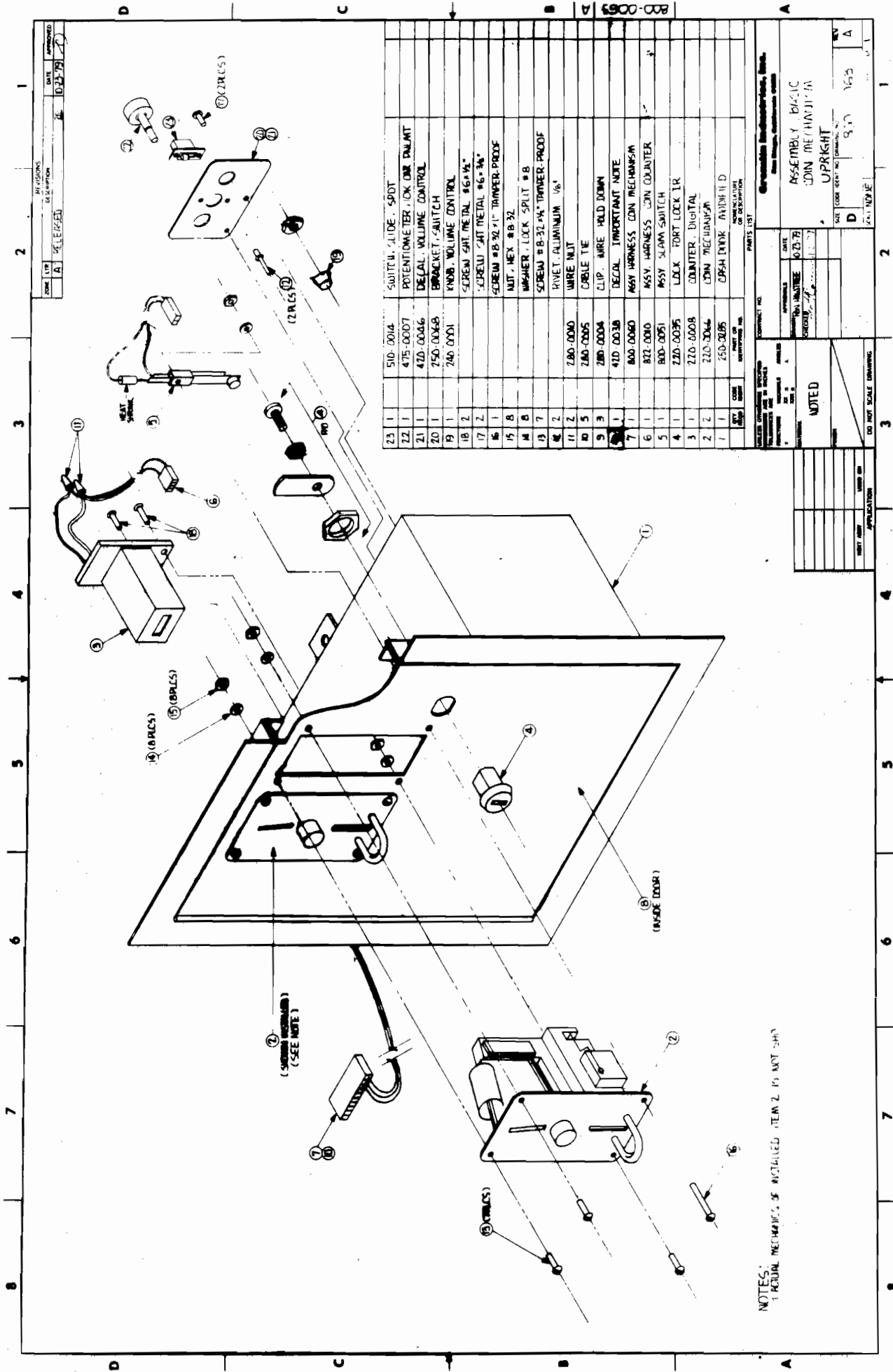

REV	DATE	APPROVED
1	10-23-79	[Signature]

QTY	CONTRACT NO.	DESCRIPTION
23	510-0004	SWITCH, SLIDE, SPDT
22	475-0007	POTENTIOMETER, LOCK ONE DIAL
21	410-0046	DECAL, VOLUME CONTROL
20	750-0068	BRACKET, SWITCH
19	740-0001	KNOB, VOLUME CONTROL
18		SCREW, SAT METAL #6-1/2"
17		SCREW #8-3/4" TAMPER-PROOF
16		NUT, HEX #8-32
15		WASHER, LOCK SPLIT #8
14		SCREW #8-3/4" TAMPER-PROOF
13		PIVET, ALUMINUM 1/8"
12		WIRE NUT
11		CABLE TIE
10		CLIP, WIRE HOLD DOWN
9		DECAL, IMPORTANT NOTE
8		ASSY, HARNESS, CON. COUNTER
7		ASSY, SLAM SWITCH
6		LOCK, FORT LOCK IR
5		COUNTER, DIGITAL
4		CON. MECHANISM
3		CRASH PINK, ANTIM H D
2		
1		

CONTRACT NO.	DATE
REV	DATE
REV	DATE
REV	DATE

NOTED

DO NOT SCALE DRAWING

NOTES:

1. ORIGINAL MECHANICS OF MOUNTING ITEM 2, IS NOT SHOWN

NOTES:

1. SECURE HARNESS USING ITEM 8, APPROX EVERY 6 INCHES.

REVISIONS				
ZONE	LTR	DESCRIPTION	DATE	APPROVED
A		RELEASED	2-8-80	<i>[Signature]</i>

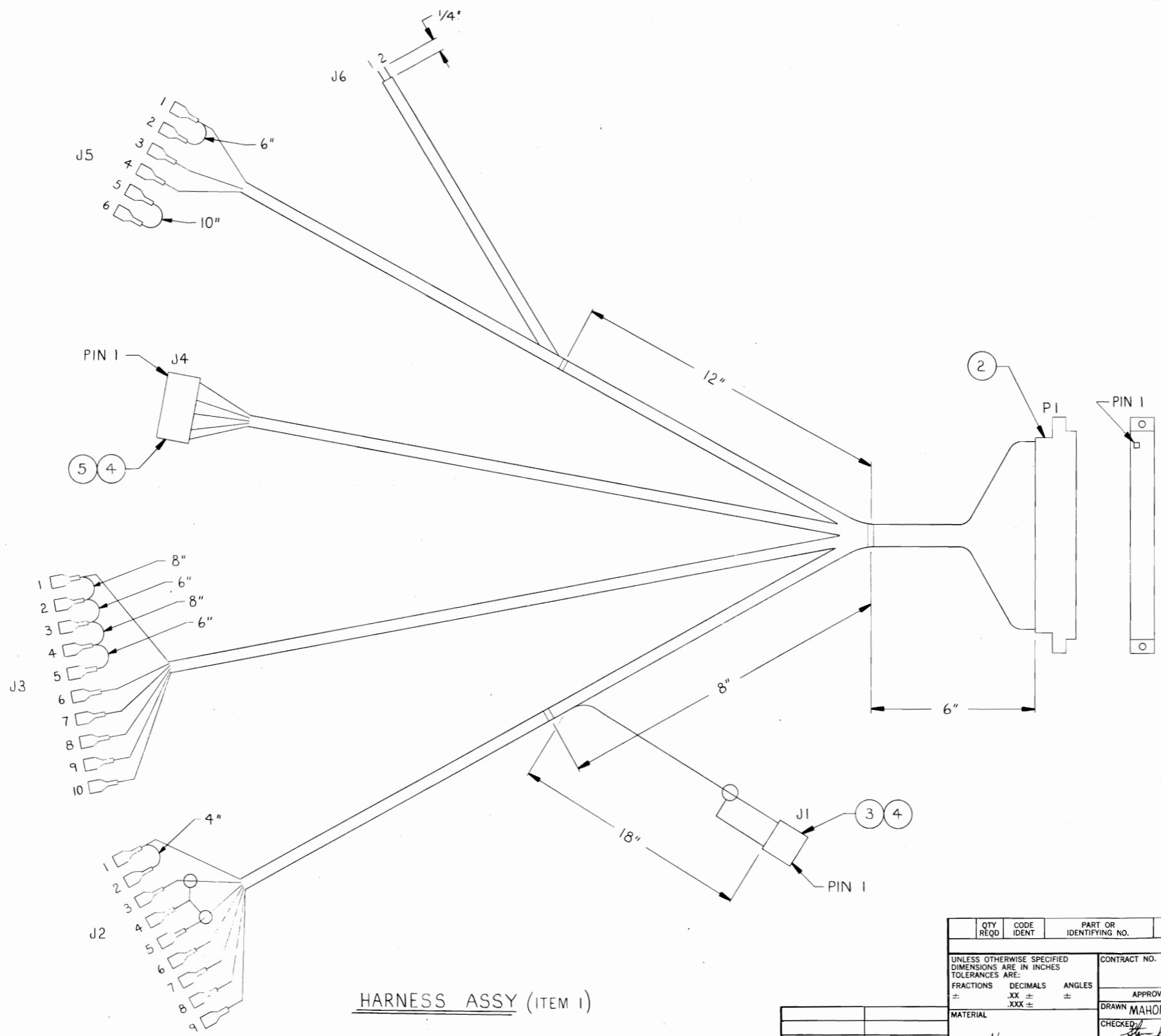

NO	WIRE FROM	TO	COLOR	INCH
47	J5-5	J5-6	JUMPER	10
46	J2-4	J1-1	SHLD. CA. GND	42
45	J2-5	J1-4	SHLD. CA. WHT	42
44	PI-22			
43	PI-21			
42	PI-20			
41	PI-19			
40	PI-18	J2-9	WHT / VIO	60
39	PI-17			
38	PI-16			
37	PI-15			
36	PI-14			
35	PI-13			
34	PI-12			
33	PI-11			
32	PI-10			
31	PI-9	J2-5	WHT / BLU	60
30	PI-8	J5-3	WHT / GRN	60
29	PI-7	J2-4	SHLD. CA. GND	42
28	PI-6	J4-8	BLK	20
27	PI-5	J4-5	BLU	20
26	PI-4	J4-1	RED	20
25	PI-3			
24	PI-2			
23	PI-1	J2-1,2 J5-4	BLK	60
22	PI-Z	J6-2	WHT / YEL	47
21	PI-Y	J6-1	WHT / ORN	47
20	PI-X			
19	PI-W			
18	PI-V	J2-6	WHT / RED	60
17	PI-U	PI-R	JUMPER	2
16	PI-T	PI-P	JUMPER	2
15	PI-S	PI-N	JUMPER	2
14	PI-R	J3-10	WHT / BRN	65
13	PI-P	J3-9	WHT / BLK	58
12	PI-N	J3-8	GRY	59
11	PI-M	J3-7	VIO	66
10	PI-L	J3-6	YEL	61
9	PI-K	J2-7	ORN	60
8	PI-J	J5-1,2	BRN	60
7	PI-H	J2-3	SHLD. CA. WHT	42
6	PI-F	J4-7	WHT	20
5	PI-E	J4-3	GRN	20
4	PI-D			
3	PI-C			
2	PI-B			
1	PI-A	J3-1,2,3,4,5	BLK	62

QTY REQD	CODE IDENT	PART OR IDENTIFYING NO.	NOMENCLATURE OR DESCRIPTION
PARTS LIST			
UNLESS OTHERWISE SPECIFIED DIMENSIONS ARE IN INCHES TOLERANCES ARE:		CONTRACT NO.	
FRACTIONS	DECIMALS	ANGLES	Gremlin Industries, Inc. San Diego, California 92123
±	.XX ±	±	
MATERIAL		APPROVALS	DATE
NOTED		DRAWN MAHONEY	2-6-80
FINISH		CHECKED <i>[Signature]</i>	2-8-80
NEXT ASSY USED ON		SIZE CODE IDENT NO. DRAWING NO.	
APPLICATION		D 800-3010	
DO NOT SCALE DRAWING		REV. A	
		SCALE NONE SHEET 3 OF 3	

HARNESS ASSY (ITEM 1)

800-3010

REVISIONS				
ZONE	LTR	DESCRIPTION	DATE	APPROVED
	A	RELEASED	2-8-80	[Signature]

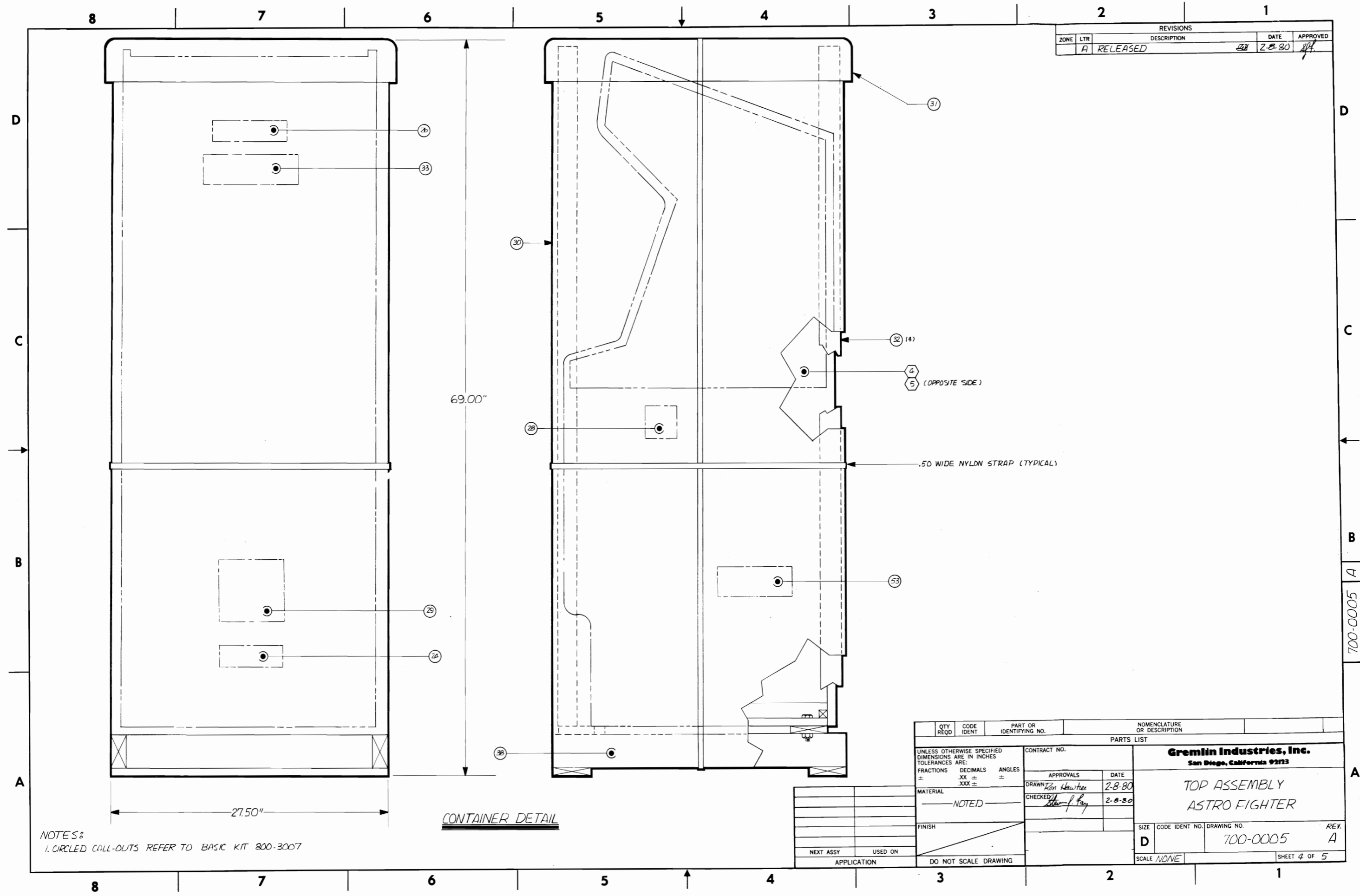

CONTAINER DETAIL

NOTES:
1. CIRCLED CALL-OUTS REFER TO BASIC KIT 800-3007

QTY REQD	CODE IDENT	PART OR IDENTIFYING NO.	NOMENCLATURE OR DESCRIPTION	
PARTS LIST				
UNLESS OTHERWISE SPECIFIED DIMENSIONS ARE IN INCHES TOLERANCES ARE:			CONTRACT NO.	
FRACTIONS ±	DECIMALS .XX ±	ANGLES .XXX ±	APPROVALS	DATE
MATERIAL			DRAWN <i>Ron Hawtree</i>	2-8-80
FINISH			CHECKED <i>W. F. Ray</i>	2-8-80
NEXT ASSY USED ON APPLICATION			Gremlin Industries, Inc. San Diego, California 92123 TOP ASSEMBLY ASTRO FIGHTER	
DO NOT SCALE DRAWING		SIZE	CODE IDENT NO.	DRAWING NO.
		D	700-0005	700-0005
		SCALE	NONE	
		SHEET 4 OF 5		

700-0005 A

REVISIONS				
ZONE	LTR	DESCRIPTION	DATE	APPROVED
	A	RELEASED	2-13-80	[Signature]
	A	B.O.M. CHG. (WIRE NUT F/N'S)	3-27-90	[Signature]

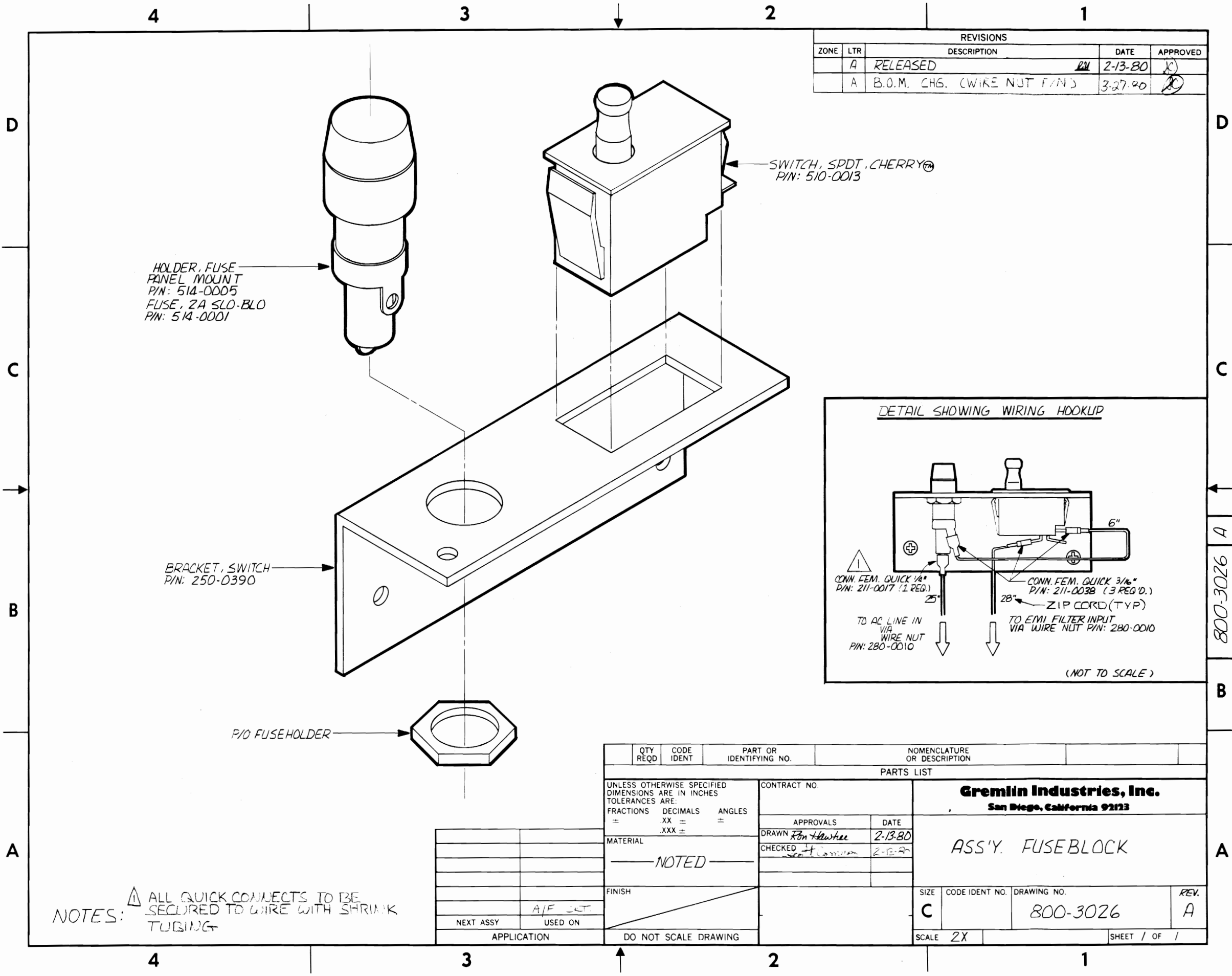

NOTES: ALL QUICK CONNECTS TO BE SECURED TO WIRE WITH SHRINK TUBING

QTY REQD	CODE IDENT	PART OR IDENTIFYING NO.	NOMENCLATURE OR DESCRIPTION
PARTS LIST			
UNLESS OTHERWISE SPECIFIED DIMENSIONS ARE IN INCHES TOLERANCES ARE: FRACTIONS DECIMALS ANGLES = XX ± = XXX ±		CONTRACT NO.	Gremlin Industries, Inc. San Diego, California 92123
MATERIAL		APPROVALS	
FINISH		DATE	ASS'Y. FUSEBLOCK
NEXT ASSY		CHECKED	
USED ON		DATE	SIZE
APPLICATION		DO NOT SCALE DRAWING	CODE IDENT NO.
			DRAWING NO.
			REV.
			C
			800-3026
			A
			SCALE 2X
			SHEET / OF /

800-3026

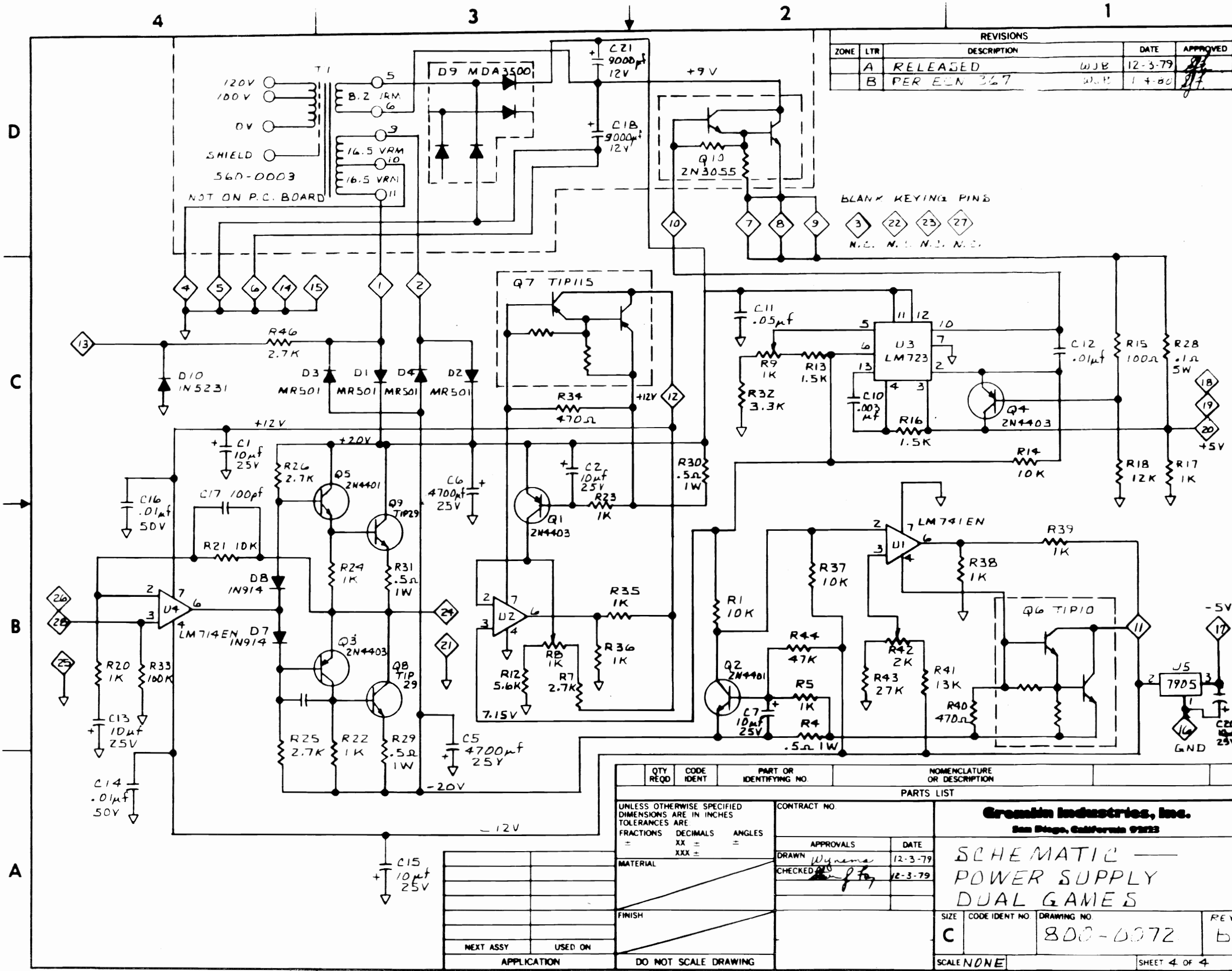

REVISIONS				
ZONE	LTR	DESCRIPTION	DATE	APPROVED
A		RELEASED	WJB 12-3-79	[Signature]
B		PER ECN 367	WJB 1-4-80	[Signature]

BLANK KEYING PINS
 3 22 23 27
 N.C. N.C. N.C. N.C.

QTY REQD	CODE IDENT	PART OR IDENTIFYING NO.	NOMENCLATURE OR DESCRIPTION
PARTS LIST			
UNLESS OTHERWISE SPECIFIED DIMENSIONS ARE IN INCHES TOLERANCES ARE FRACTIONS DECIMALS ANGLES = XX ± = XXX ± =		CONTRACT NO.	Gremm Industries, Inc. San Diego, California 92123
MATERIAL		APPROVALS DATE DRAWN Wynema 12-3-79 CHECKED [Signature] 12-3-79	
FINISH		SCHEMATIC — POWER SUPPLY DUAL GAMES	
NEXT ASSY USED ON APPLICATION		SIZE CODE IDENT NO. DRAWING NO. REV C 800-0072 B	SCALE NONE SHEET 4 OF 4

REVISIONS				
ZONE	LTR	DESCRIPTION	DATE	APPROVED
A		RELEASED	WJB	2-12-80

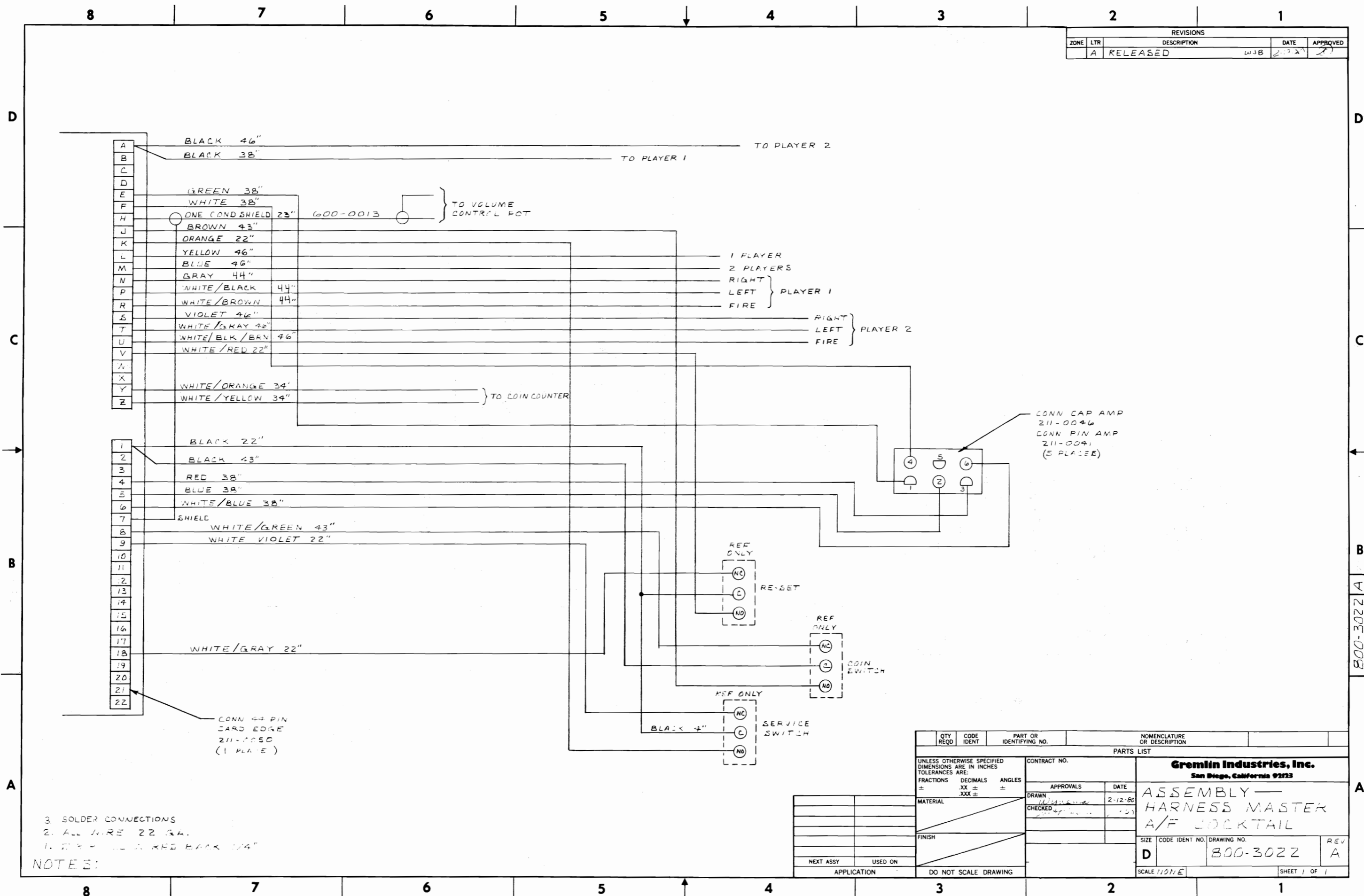

CONN CAP AMP
211-0046
CONN PIN AMP
211-0041
(5 PLACES)

CONN 44 PIN
CARD EDGE
211-0050
(1 PLACE)

NOTES:
3. SOLDER CONNECTIONS
2. ALL WIRE 22 GA.
1. STRIP ALL RED BACK 1/4"

QTY REQD	CODE IDENT	PART OR IDENTIFYING NO.	NOMENCLATURE OR DESCRIPTION
PARTS LIST			
UNLESS OTHERWISE SPECIFIED DIMENSIONS ARE IN INCHES TOLERANCES ARE: FRACTIONS ± .005 DECIMALS ± .001 ANGLES ± .01		CONTRACT NO.	
MATERIAL		APPROVALS	DATE
FINISH		DRAWN: [Signature] 2-12-80	
NEXT ASSY		CHECKED: [Signature]	
USED ON		SIZE: D	
APPLICATION		DRAWING NO.: 800-3022	
DO NOT SCALE DRAWING		SCALE: NONE	
		SHEET 1 OF 1	

Gremlin Industries, Inc.
San Diego, California 92123

ASSEMBLY —
HARNESS MASTER
A/F JOCKTAIL

800-3022 A

REVISIONS				
ZONE	LTR	DESCRIPTION	DATE	APPROVED
A	RELEASED		2-11-80	<i>[Signature]</i>

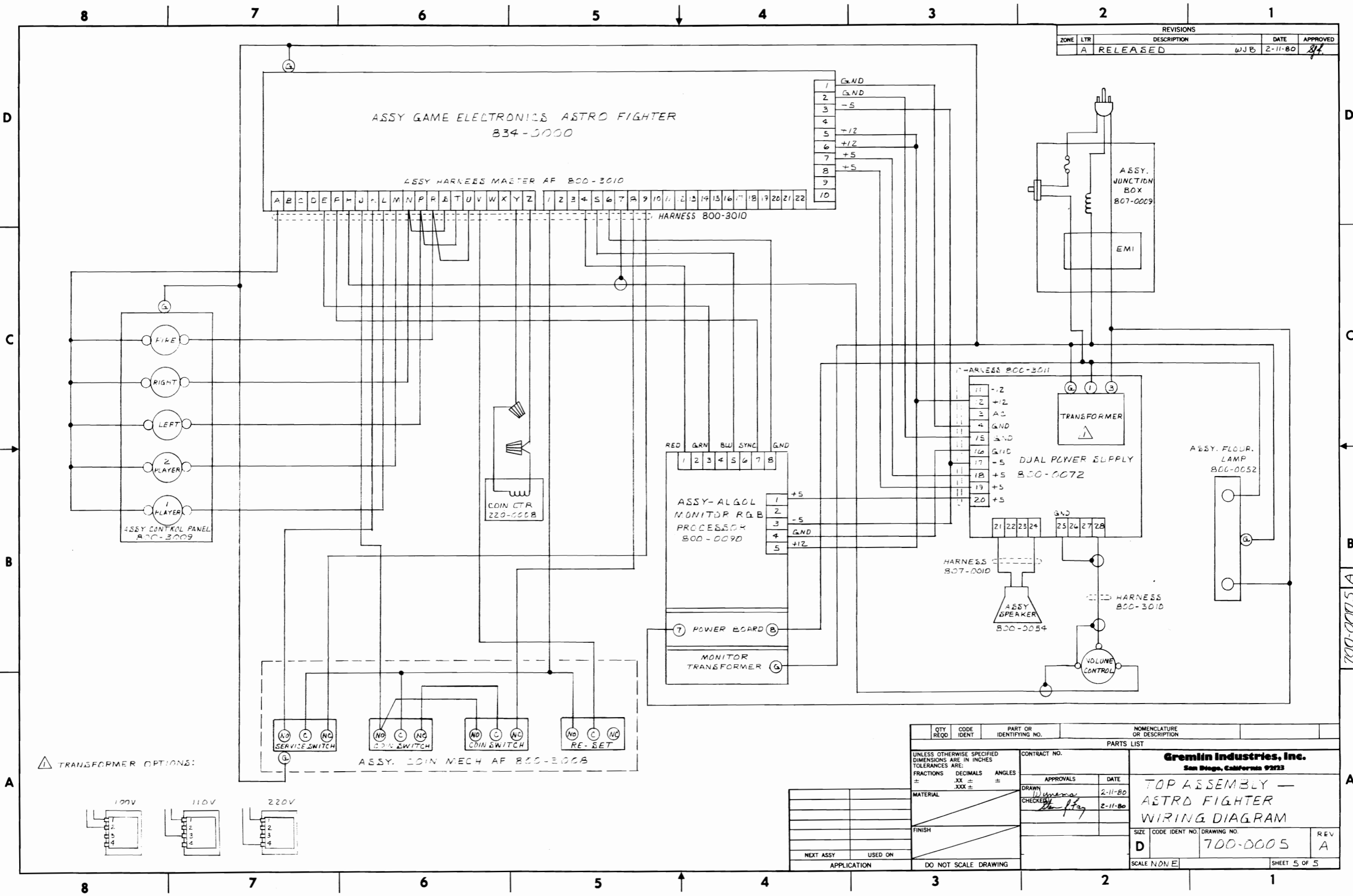

QTY REQD	CODE IDENT	PART OR IDENTIFYING NO.	NOMENCLATURE OR DESCRIPTION
			Gremlin Industries, Inc. San Diego, California 92123
UNLESS OTHERWISE SPECIFIED DIMENSIONS ARE IN INCHES TOLERANCES ARE:		CONTRACT NO.	APPROVALS DATE <i>[Signature]</i> 2-11-80 <i>[Signature]</i> 2-11-80
FRACTIONS	DECIMALS	ANGLES	
±	±	±	DRAWN BY <i>[Signature]</i>
			CHECKED BY <i>[Signature]</i>
MATERIAL		FINISH	
NEXT ASSY		USED ON	
APPLICATION		DO NOT SCALE DRAWING	
SIZE		CODE IDENT NO.	DRAWING NO.
D			700-0005
SCALE		SHEET 5 OF 5	

700-0005 A

REVISIONS				
ZONE	LTR	DESCRIPTION	DATE	APPROVED
A		RELEASED	w.j.e. 4-14-80	T.J.

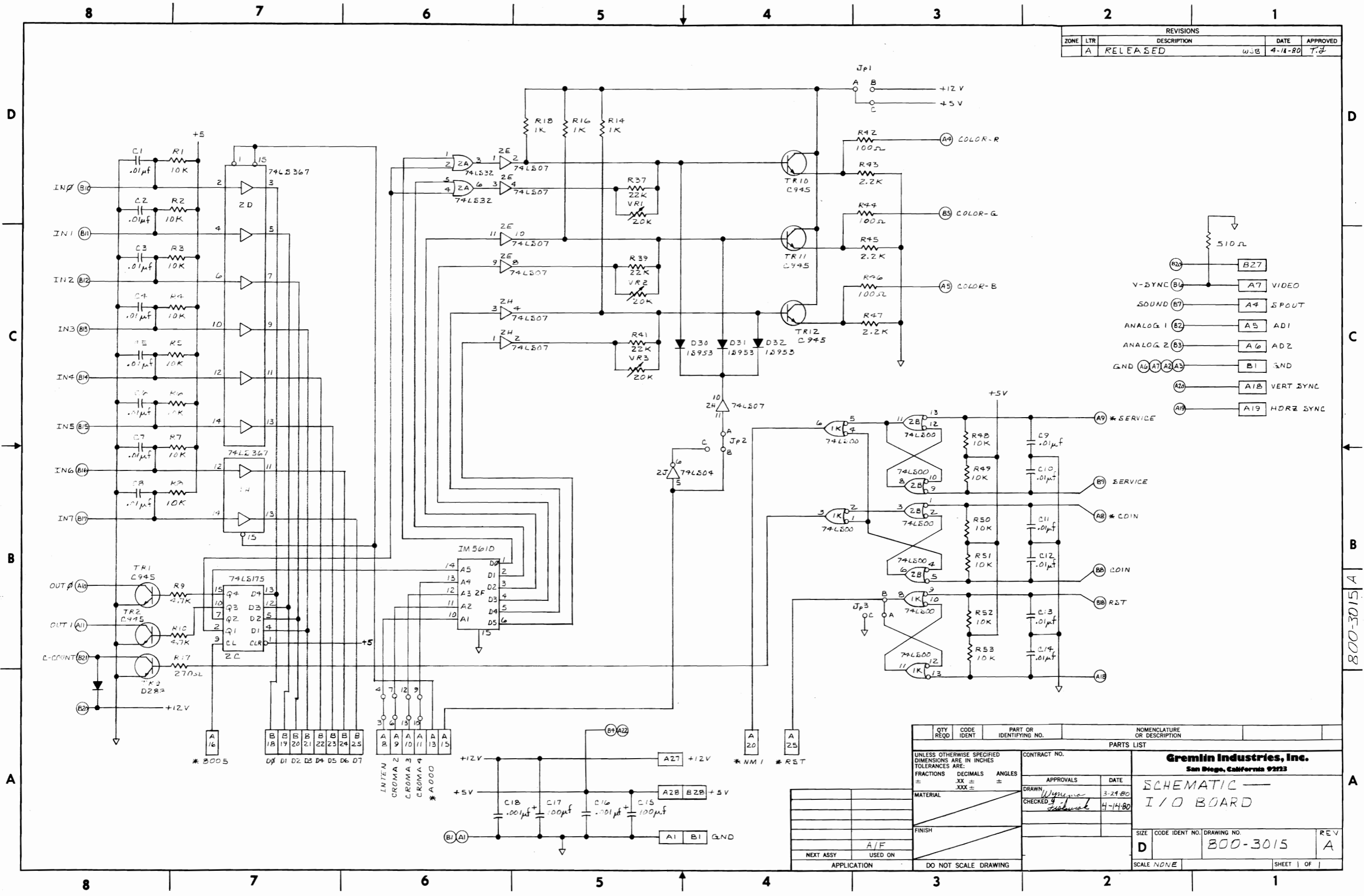

QTY REQD	CODE IDENT	PART OR IDENTIFYING NO.	NOMENCLATURE OR DESCRIPTION
PARTS LIST			
Gremlin Industries, Inc. San Diego, California 92123			
UNLESS OTHERWISE SPECIFIED DIMENSIONS ARE IN INCHES TOLERANCES ARE:		CONTRACT NO.	
FRACTIONS	DECIMALS	ANGLES	APPROVALS
±	±	±	DATE
±	±	±	3-24-80
MATERIAL		DRAWN <i>Wymona</i>	
FINISH		CHECKED <i>Subal</i>	
NEXT ASSY USED ON		DATE	
APPLICATION		4-14-80	
DO NOT SCALE DRAWING		SIZE CODE IDENT NO. DRAWING NO.	
SCALE NONE		D 800-3015 A	
SHEET 1 OF 1		REV A	

800-3015 A

REVISIONS				
ZONE	LTR	DESCRIPTION	DATE	APPROVED
A		RELEASED	LH 4-14-80	T.L.

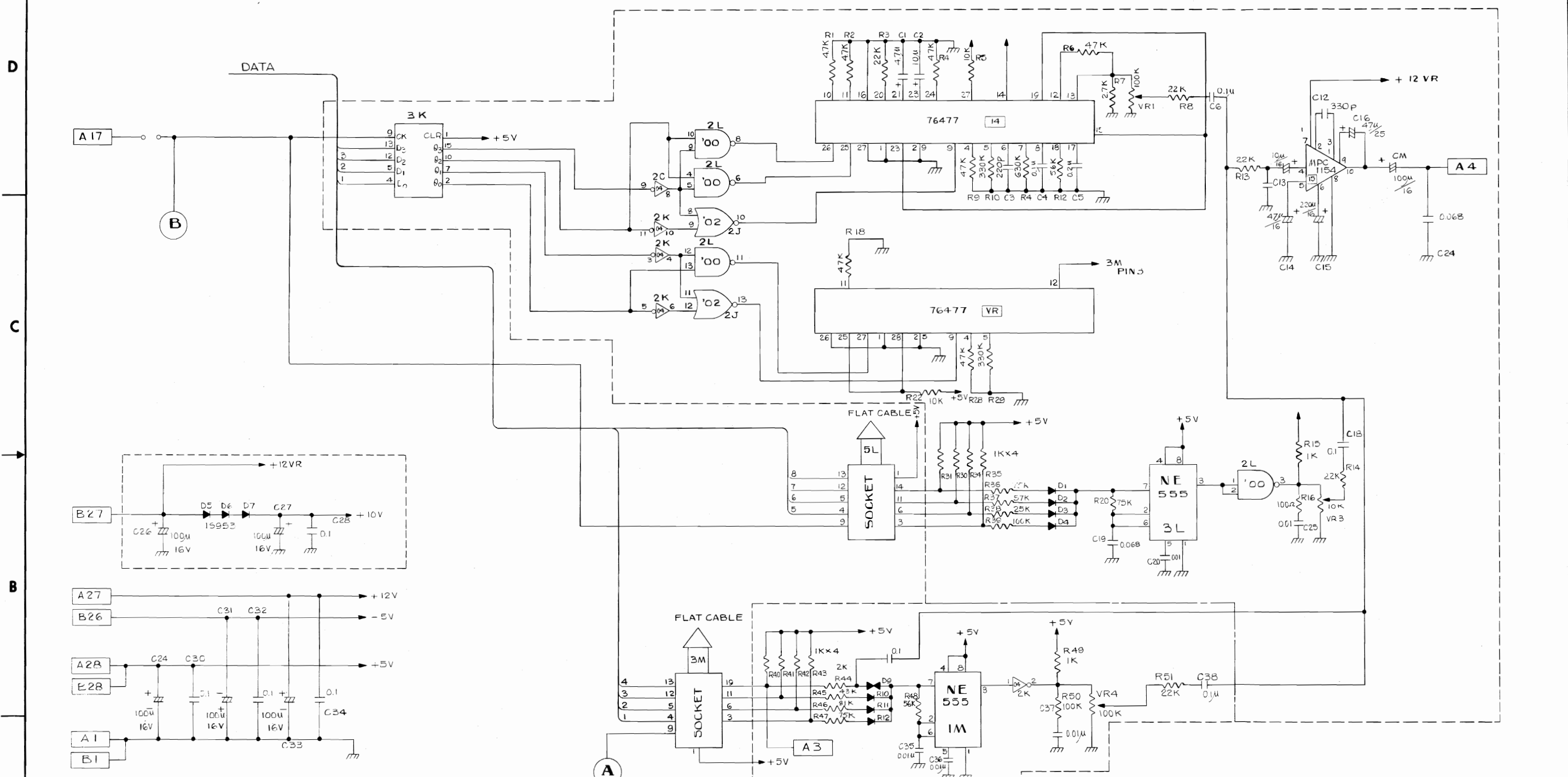

NOTES:
 SECTIONS OF BOARD INDICATED BY DASHED LINES APPLICABLE ONLY TO CERTAIN CONFIGURATIONS OF BOARDS.

QTY REQD	CODE IDENT	PART OR IDENTIFYING NO.	NOMENCLATURE OR DESCRIPTION
PARTS LIST			
UNLESS OTHERWISE SPECIFIED DIMENSIONS ARE IN INCHES TOLERANCES ARE:		CONTRACT NO.	
FRACTIONS ±	DECIMALS .XX ±	ANGLES ° ±	
MATERIAL		APPROVALS	DATE
FINISH		DRAWN LIEN VAN HO	4.8.80
NEXT ASSY USED ON		CHECKED <i>Liouan</i>	4-14-80
APPLICATION		DO NOT SCALE DRAWING	

Gremlin Industries, Inc. San Diego, California 92123	
ASSEMBLY ROM BOARD	
SIZE D	CODE IDENT NO. DRAWING NO. 800_3016
SCALE NONE	REV A
SHEET 2 OF 2	

8

7

6

5

4

3

2

1

REVISIONS				
ZONE	LTR	DESCRIPTION	DATE	APPROVED
A		RELEASED	4-14-80	T.L.

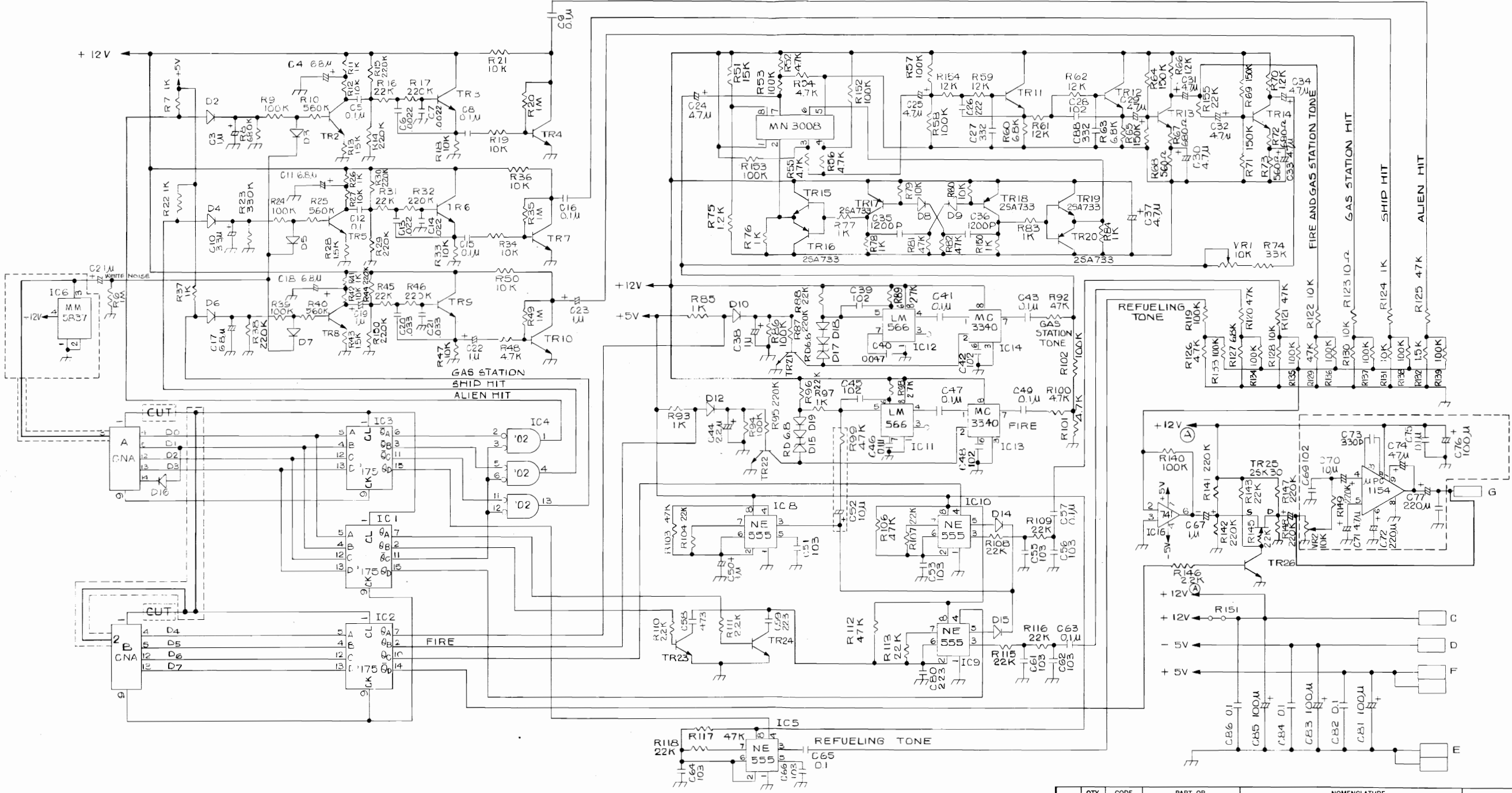

NOTES:
 SECTIONS OF BOARD INDICATED BY
 DASHED LINES APPLICABLE ONLY
 TO CERTAIN CONFIGURATIONS OF
 BOARDS.

QTY REQD	CODE IDENT	PART OR IDENTIFYING NO.	NOMENCLATURE OR DESCRIPTION
PARTS LIST			
UNLESS OTHERWISE SPECIFIED DIMENSIONS ARE IN INCHES TOLERANCES ARE:		CONTRACT NO.	
FRACTIONS	DECIMALS	ANGLES	APPROVALS
±	.xx ±	±	DATE
	.xxx ±		
MATERIAL		DRAWN LIEN VAN HO 3-24-80	
FINISH		CHECKED <i>Isbueh</i> 4-14-80	
NOTED		DATE	
NEXT ASSY USED ON		DRAWING NO.	
APPLICATION		800-3017	
DO NOT SCALE DRAWING		REV A	
SCALE NONE		SHEET 1 OF 1	

Gremlin Industries, Inc.
 San Diego, California 92123

**SCHEMATIC
 AUDIO BOARD**

SIZE D CODE IDENT NO. 800-3017 REV A

800-3017

A

D

C

B

A

D

C

B

A

REVISIONS				
ZONE	LTR	DESCRIPTION	DATE	APPROVED
A		RELEASED	L.H.	4-14-80

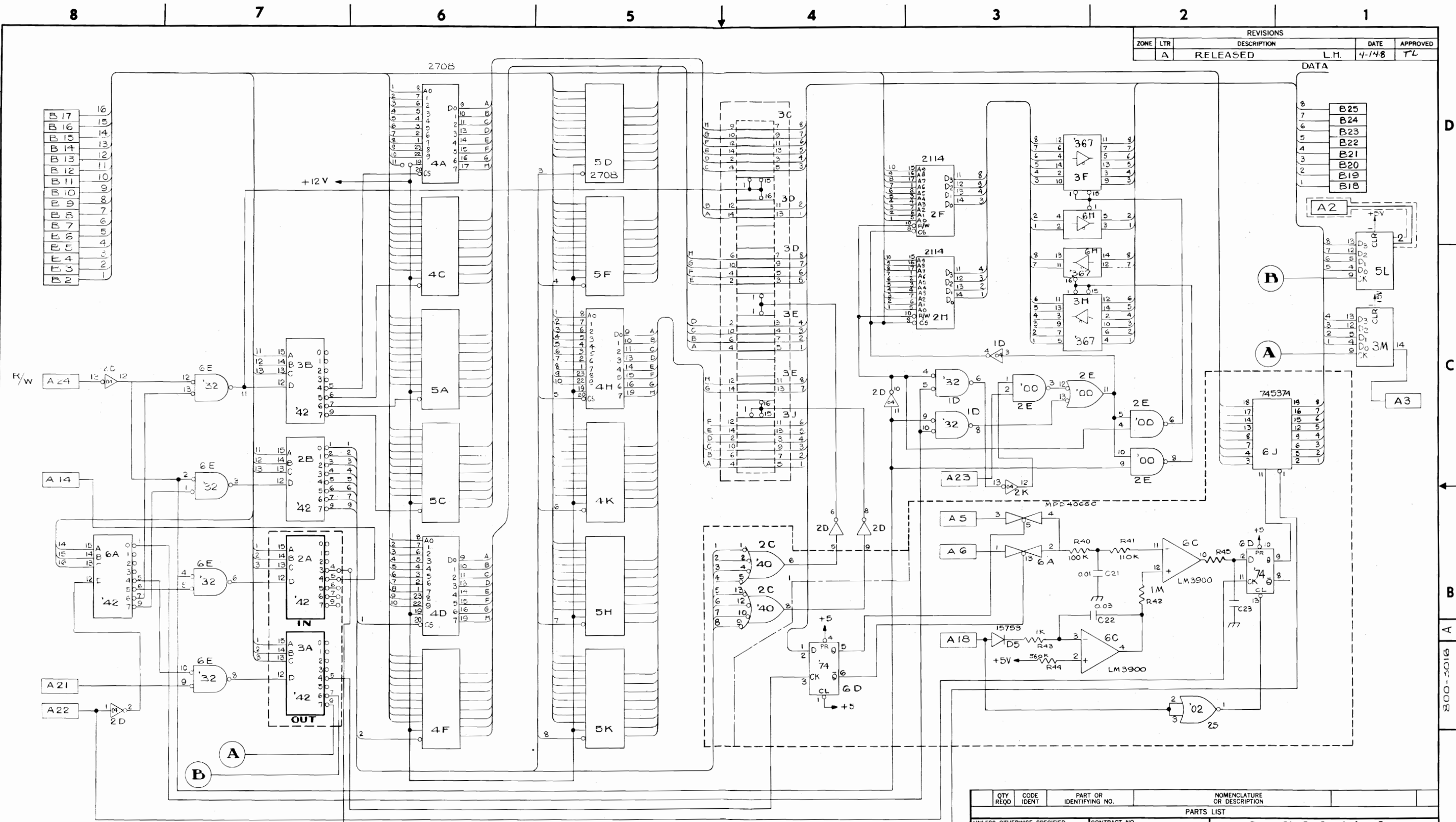

NOTES:

1. SECTIONS OF BOARD INDICATED BY DASHED LINES APPLICABLE ONLY TO CERTAIN CONFIGURATIONS OF BOARDS.
2. 2708 PIN # 21 -5V, # 24 +5V, # 19 +12V, # 12 GND.
3. 2114 # 9 GND, # 18 +5V.
4. 3C, 3D, 3E, 3J, - WILL EITHER BE JUMPED OR USE 74LS367

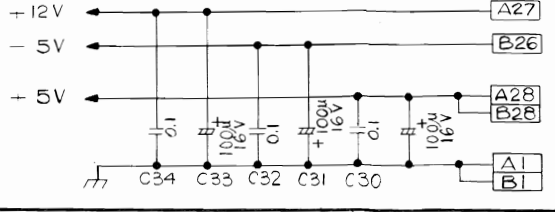

QTY REQD	CODE IDENT	PART OR IDENTIFYING NO.	NOMENCLATURE OR DESCRIPTION
PARTS LIST			
UNLESS OTHERWISE SPECIFIED DIMENSIONS ARE IN INCHES TOLERANCES ARE:		CONTRACT NO.	
FRACTIONS	DECIMALS	ANGLES	
±	±	±	
MATERIAL		APPROVALS	
FINISH		DATE	
NEXT ASSY USED ON		DRAWN LIEN VAN MO	
APPLICATION		CHECKED <i>Asakawa</i>	
DO NOT SCALE DRAWING		4-14-80	

Gremlin Industries, Inc. San Diego, California 92123	
ASSEMBLY ROM BOARD	
SIZE	CODE IDENT NO. DRAWING NO.
D	800-3016
SCALE NONE	REV A
SHEET 1 OF 2	

800-3016 A

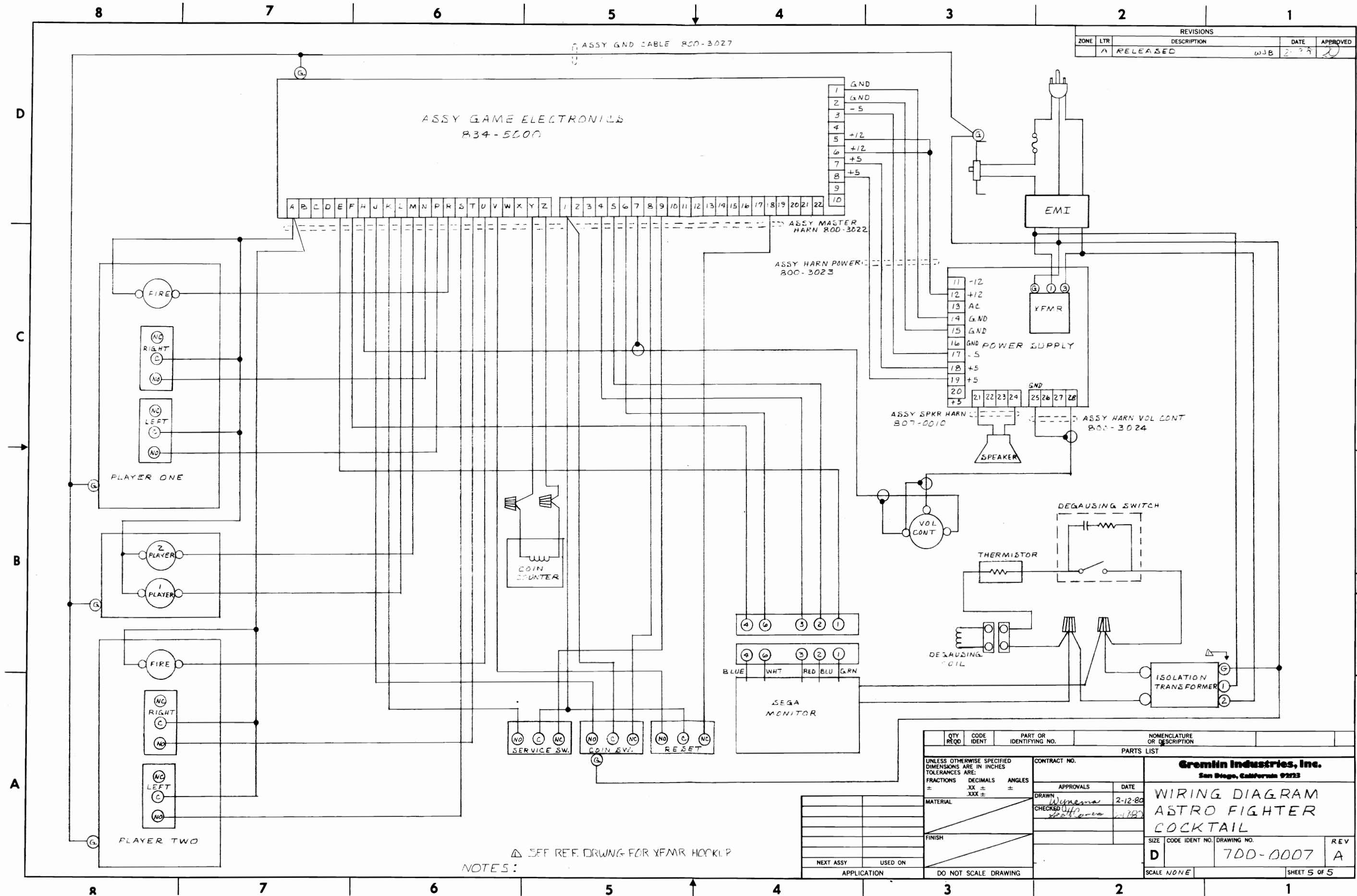

REVISIONS				
ZONE	LTR	DESCRIPTION	DATE	APPROVED
A		RELEASED	WJB 2-7-80	

NOTES:
 ▲ SEE REF. DRWG FOR YFMR HOOKUP

QTY REQD	CODE IDENT	PART OR IDENTIFYING NO.	NOMENCLATURE OR DESCRIPTION
PARTS LIST			
UNLESS OTHERWISE SPECIFIED DIMENSIONS ARE IN INCHES TOLERANCES ARE:		CONTRACT NO.	
FRACTIONS	DECIMALS	ANGLES	APPROVALS
±	.XX ±	XXX ±	DATE
MATERIAL		DRAWN <i>Wynema</i> 2-12-80	
FINISH		CHECKED <i>[Signature]</i> 2-18-80	
NEXT ASSY USED ON		Gremlin Industries, Inc. San Diego, California 92123 WIRING DIAGRAM ASTRO FIGHTER COCKTAIL	
APPLICATION		SIZE	REV
DO NOT SCALE DRAWING		D	A
		SCALE NONE	SHEET 5 OF 5

700-0007 A

REVISIONS				
ZONE	LTR	DESCRIPTION	DATE	APPROVED
A		RELEASED	LH 4-14-80	TJ

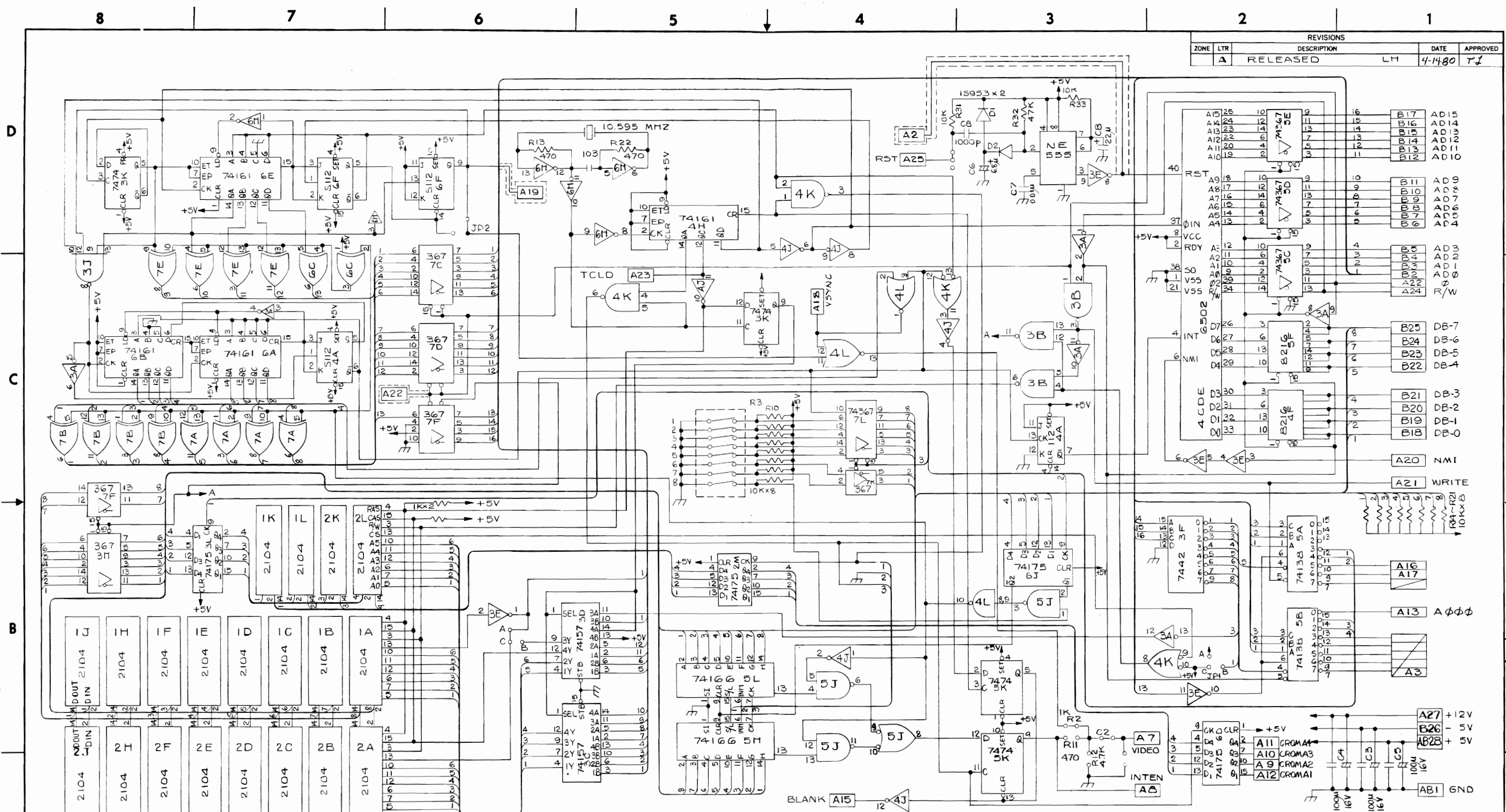

NOTES :
 SECTIONS OF BOARD INDICATED BY DASHED LINES APPLICABLE ONLY TO CERTAIN CONFIGURATIONS OF BOARD.

QTY REQD	CODE IDENT	PART OR IDENTIFYING NO.	NOMENCLATURE OR DESCRIPTION
PARTS LIST			
UNLESS OTHERWISE SPECIFIED DIMENSIONS ARE IN INCHES TOLERANCES ARE:		CONTRACT NO.	
FRACTIONS	DECIMALS	ANGLES	
=	XX ±	°	
	XXX ±		
MATERIAL		APPROVALS	
FINISH		DATE	
NEXT ASSY USED ON		DRAWN LIEN VAN HO 4-14-80	
APPLICATION		CHECKED [Signature] 4-14-80	
DO NOT SCALE DRAWING		Gremlin Industries, Inc. San Diego, California 92123	
		ASSEMBLY CPU BOARD	
SIZE	CODE IDENT NO. DRAWING NO.	REV	
D	800-3014	A	
SCALE NONE	SHEET 1 OF 1		

REVISIONS				
ZONE	LTR	DESCRIPTION	DATE	APPROVED
A		RELEASED	J.M. 2-8-80	<i>[Signature]</i>
B		CHG'D PER ECN 378	SB 3-10-80	<i>[Signature]</i>

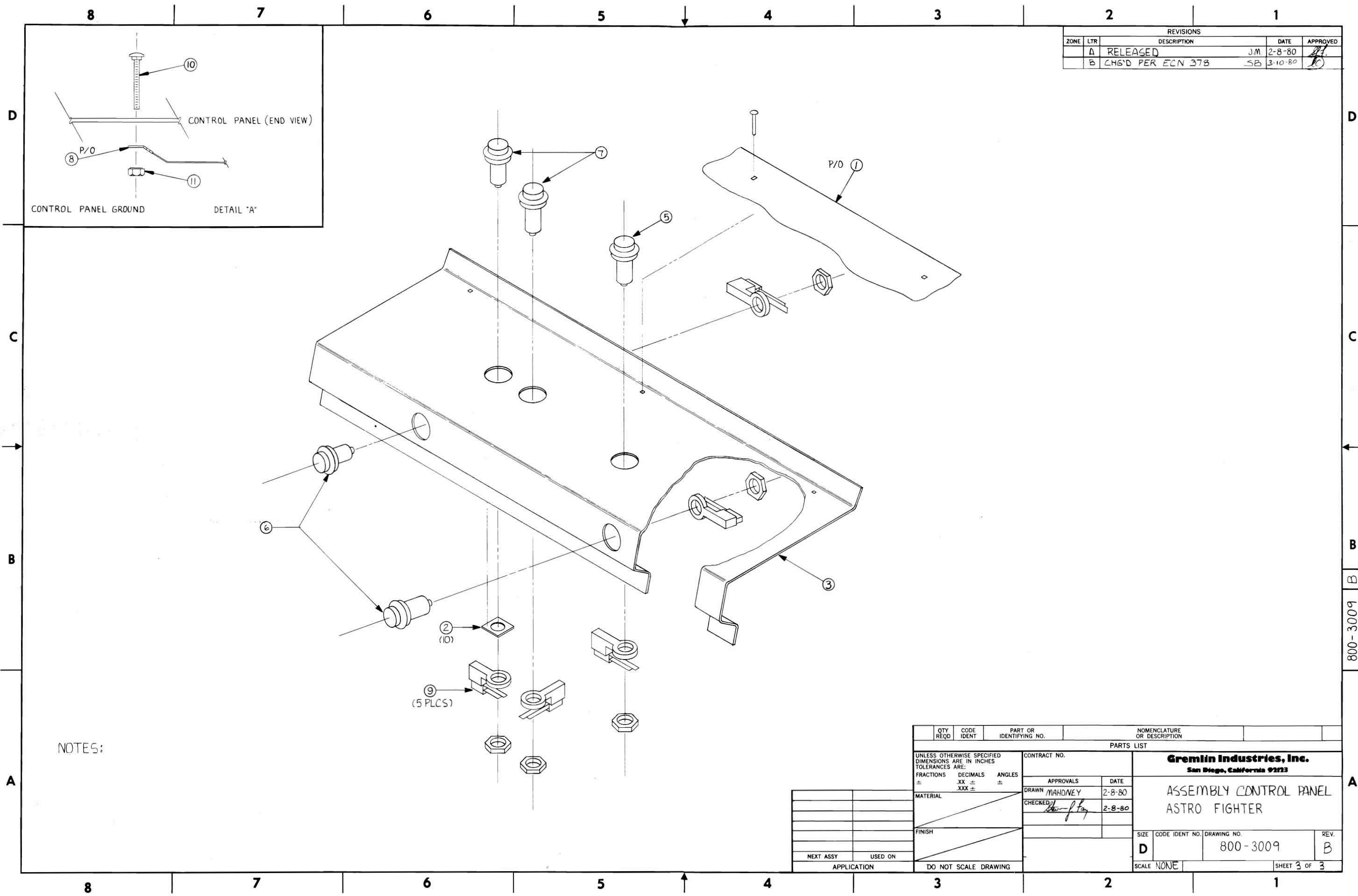

NOTES:

QTY REQD	CODE IDENT	PART OR IDENTIFYING NO.	NOMENCLATURE OR DESCRIPTION	
PARTS LIST				
UNLESS OTHERWISE SPECIFIED DIMENSIONS ARE IN INCHES TOLERANCES ARE:			Gremlin Industries, Inc. San Diego, California 92123	
FRACTIONS	DECIMALS	ANGLES	APPROVALS	DATE
±	.XX ±	±	DRAWN MAHONEY	2-8-80
	.XXX ±		CHECKED <i>[Signature]</i>	2-8-80
MATERIAL			CONTRACT NO.	
FINISH			DRAWING NO.	
NEXT ASSY			USED ON	
APPLICATION			DO NOT SCALE DRAWING	
SIZE	CODE IDENT NO.	DRAWING NO.	REV.	
D		800-3009	B	
SCALE NONE			SHEET 3 OF 3	

800-3009

REVISIONS				
ZONE	LTR	DESCRIPTION	DATE	APPROVED
A	RELEASED		2-8-80	[Signature]

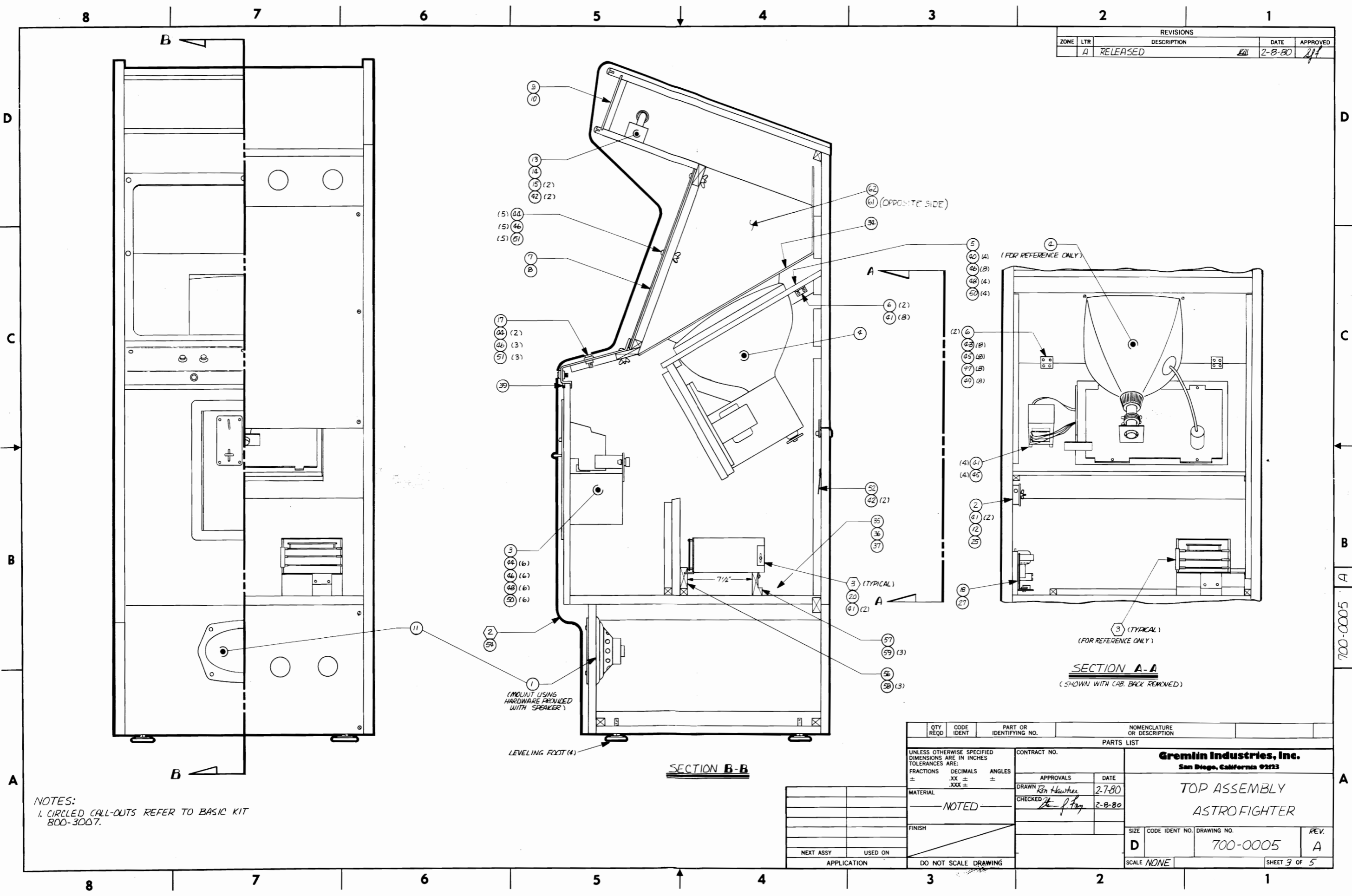

NOTES:
 1. CIRCLED CALL-OUTS REFER TO BASIC KIT 800-3007.

QTY REQD	CODE IDENT	PART OR IDENTIFYING NO.	NOMENCLATURE OR DESCRIPTION
PARTS LIST			
UNLESS OTHERWISE SPECIFIED DIMENSIONS ARE IN INCHES TOLERANCES ARE:		CONTRACT NO.	
FRACTIONS ±	DECIMALS .XX ±	ANGLES ±	
MATERIAL		APPROVALS	DATE
NOTED		DRAWN <i>Ken Hawtree</i>	2-7-80
FINISH		CHECKED <i>De-fay</i>	2-8-80
NEXT ASSY USED ON		GREMLIN INDUSTRIES, INC. San Diego, California 92123	
APPLICATION		TOP ASSEMBLY ASTROFIGHTER	
DO NOT SCALE DRAWING		SIZE D	CODE IDENT NO. 700-0005
		SCALE NONE	DRAWING NO. 700-0005
		REV. A	
		SHEET 3 OF 5	

700-0005