

**HOOD**

**PART NO.  
420-0193**

MANUFACTURED BY

**Gremlin<sup>®</sup>**  
Industries, inc.

**OWNER'S MANUAL**

HEAD ON  
OPERATING INSTRUCTIONS  
AND  
SERVICE MANUAL

HEAD ON OWNER'S MANUAL

Copyright © 1979 by Gremlin Industries, Inc. All Rights Reserved  
All the information contained herein is the exclusive proprietary property  
of GREMLIN INDUSTRIES and is disclosed in confidence and may not be duplicated  
nor copied in whole or part, nor be used for any purposes other than that for  
which disclosed.

## TABLE OF CONTENTS

	Page
INTRODUCTION	1
IMPORTANT NOTE	2
REPACKAGING INSTRUCTIONS	3
GAME CONCEPT	4
MAINTENANCE PROCEDURES	6
TRANSFORMER VOLTAGE CONVERSION INSTRUCTIONS	8
SCHEMATICS	Following Pages

## INTRODUCTION

This is an electronic game that makes extensive use of digital integrated circuitry and television monitor circuitry. This manual assumes the maintenance technician possesses a general knowledge of solid state circuitry, microprocessor, TTL digital integrated circuitry and T.V. monitor concepts. Any individual NOT knowledgeable in these areas SHOULD NOT attempt repair of the electronic portion of this game. IT SHOULD BE NOTED THAT ANY ATTEMPT TO REPAIR THE GAME IN THE FIELD WITHOUT EXPRESS CONSENT OF THE FACTORY WILL IMMEDIATELY VOID THE WARRANTY!!!

### IMPORTANT NOTES:

- NEVER replace any components with anything other than exact replacement parts. (See Parts List located on Service Schematics.
  - NEVER remove circuit boards/connections while power is on.
  - DO NOT replace the fuse with anything other than the proper value. A blown fuse indicates an overload condition within the game. Replacing the fuse with a higher value can cause severe damage to internal components if an overload occurs.
  - ALWAYS consult the manual before attempting repairs.
- CORRESPONDENCE regarding this game should be addressed to:

GREMLIN INDUSTRIES, INC.

8401 Aero Drive

San Diego, California 92123

(714) 277-8700

### IMPORTANT NOTE

An important service note is posted in this game and is repeated here for emphasis:

IF AT ANY TIME THE T. V. SCREEN SHOWS A MEANINGLESS DISPLAY  
OR THE GAME OTHERWISE MALFUNCTIONS, SIMPLY DROP A COIN INTO  
THE COIN MECHANISM. THIS SHOULD CORRECT THE PROBLEM. IF  
NOT, THE GAME REQUIRES SERVICE.

The circuitry in this game has been arranged so that the insertion of a quarter through the coin mechanism will reset the system. This clears up temporary problems caused by power line disturbances, static, etc.

#### SERVICE TECHNICIAN NOTE:

The system reset circuitry described above requires that the coin counter is attached to the system. If there is a coin counter problem and no replacement is available, the game will function properly if a 10K 0hm resistor is connected across the coin counter input pins to the video logic board.

## REPACKAGING INSTRUCTIONS

Should it be necessary to ship this game, follow the instructions below for game recrating:

- A) If the original shipping bolts have been discarded (Ref.1), obtain four 5/16-18x1 3/4" hex head bolts with 5/16" flat washers. Carefully lay the game on its side and attach skid (Ref.2).
- B) Place game upright. Tape game keys to upper flange of operator's panel (Ref.3). Crate the game using appropriate shock-absorbent packing material (Ref.4). Include padding on all four corners of the game (Ref.5). After crating is completed, secure package with strapping (Ref.6).

NOTE: If the game is to be shipped to GREMLIN for service or repair, attach a tag identifying the distributor and indicate the service or repair to be made; include the full serial number of the game. GAME MUST BE SHIPPED PREPAID.

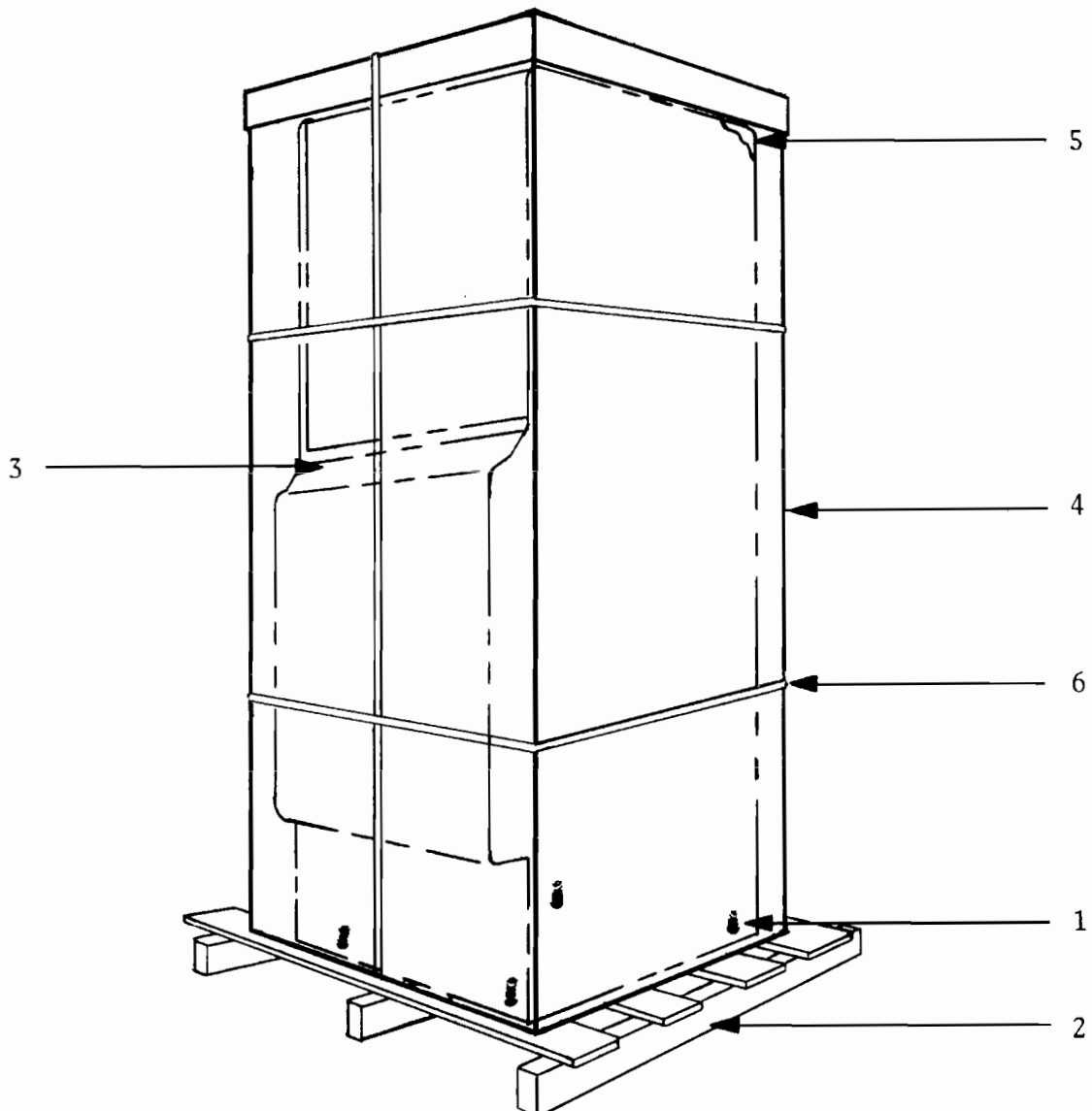

## GAME CONCEPT - HEAD ON

HEAD ON is a single-player video driving game. A player steers his car around the screen track, gaining as many points as possible in the time allotted. By maneuvering his car through the lanes, the player erases the markers in each lane for high score. But, the game has an additional element of challenge- the computer's car. It also moves around the track, in the opposite direction, and presents a test of skill by challenging the player to outsmart its moves and avoid a crash.

Both the player's car and the computer's car (it's the hollow one) start at the bottom of the screen. As the player moves his car around the track, he clears the lane markers and adds points to his score. He must judge which lane to stay in or move to, depending on where the computer's car is. With the control panel joystick and accelerator button, the player controls not only his car's speed, either fast or slow, but also the number of lane changes he can make. For example, the player sees he can avoid the other car by making a lane change. Depending on how fast he is moving, the player can maneuver his car to change one or two lanes. If the car is moving fast, the player can make only one lane change; at slow speed, two lane changes are possible. Play continues in this manner, with the player continually trying to predict where the computer car will go, so that the two cars won't crash. If they do, the game resets the cars to the starting line and the lane markers reappear. The player again tries to clear as many lane markers as possible before time runs out. While game time is 90 seconds, play continues after that time to allow the player a last chance to clear any remaining lane markers. If he does this, the game gives a bonus time of 30 seconds. If he crashes, the game ends. The bonus time is awarded any time the player clears all the lane markers without crashing.

Each lane is given a point value, as shown in the track infield. At game start, each lane is worth 5 points. This value increases by 5 points each time the player clears all the lane markers. Also, the three highest scores to date are displayed on the track infield.

## GAME CONCEPT cont'd.

As mentioned above, the computer's car adds challenge to the game action. At first, the player may have no difficulty avoiding the computer's car; but, as the game progresses, and the player's score increases, predicting which way the computer car will go becomes harder. This feature allows for a variety of player skill levels.

HEAD ON is played with two controls- a joystick and push button. The joystick allows the player to make a lane change up, down, or left or right, depending on which part of the track his car is located. The push button controls the speed: Push down to move the car faster; release it to slow the car down.

HEAD ON has a complete set of sounds to highlight the action. Each car has its own engine sound; both the player's car and computer's car have different sounds for fast and slow speeds. Also, both cars produce a screech sound at each corner of the track, and when changing lanes. A sensational explosion occurs whenever the cars collide.

There are two options in HEAD ON: The number of coins per game (1,2,3,or 4) and, sound off during advertising. To select 2, 3, or 4 coins per game (the game is shipped in the 1 coin per game mode) a jumper is connected from ground (pin 10 on the player control connector on the logic board) to pin 3 for 2 coins per game, or to pin 4 for 3 coins. Both pins 2 and 3 are grounded for 4 coins per game. To turn off the advertising sound, simply turn the sound switch, located inside the coin door, to "OFF".



MAINTENANCE PROCEDURES- HEAD ON

I. POWER SUPPLY (refer to drawing #815-0020, sheet 4)

1. Remove output connectors from power supply.
2. Make these initial tests: (GND to BLACK lead on c18, 9000 mfd capacitor)
  - a) +9 V DC on POSITIVE terminal of C18
  - b) +17-19 V on C6 (4700 mfd. cap.)
  - c) -17-19 V on C5 (4700 mfd. cap.)
  - d) -12 V at pin 11 (adjustable by trim pot R42)
  - e) +12 V at pin 12 (adjustable by trim pot R8 )
  - f) +5 V at pins 18-20 (adjustable by trim pot R9)
  - g) GND (ground, 0 V) at pins 14-16
  - h) 2-3 V AC at pin 13 (Don't forget to change meter scale to AC)
3. Check these voltages again with the logic board connected. If any are wrong, a loading problem exists in the logic board, most likely.  
Possible causes of a short on the logic board could be: U73, C21, C25, or C26.

II. SOUND BOARD (refer to drawing #822-0002, sheet 6)

1. If no sounds are produced:
  - a) check connections between logic board (labelled "Sound Out") and Sound board (pins 1 through 14) and between the Sound board and the Power Supply.
  - b) If they are good, check IC U16 on the logic board, pins 2,5,6,9,12, 15,16,and 19 for outputs when each sound is produced.
  - c) If the outputs are present, check the output of the sound board, pin 5. If the signals are present here (use an oscilloscope for best results) check the amplifier circuit on the power supply, specifically, U4, Q8, and Q9.

2. If some sounds are produced, but not all:

a) repeat steps a and b, above.

b) If these prove OK, check the specific circuit for each sound:

SOUND TYPE:	SOUND BOARD PIN #:	CHECK THESE PARTS:
Crash	Pin 1	Q2, U2, U1, U13
High Speed (computer car)	Pin 2	Q8, U9, U8, U7
Car on	Pin 3	Q9, Q6, U9, U12, Q10, U6, U5

MAINTENANCE PROCEDURES- cont'd.

High Speed (player car)	Pin 4	Q12, Q10, U12, U6, U5
Screech #1	Pin 6	Q14, U10, D7
Screech #2	Pin 7	Q13, U10, D6
Bonus	Pin 8	Q5, U4, U10, D8, C19

III. LOGIC BOARD (refer to drawing #822-0001, sheets 4,5, and 6)

1. Game does not reset at power on: (see sheet 5)
  - a) check connector pin 3 on logic board for 3 V AC signal. Also, check Q10, Q11, U55, U54, and U71.
2. No video: (see sheet 5)
  - a) check U48 (part #315-0042) for video signals. Also, check U41, Q6 and Q7 for the video signals.
3. Game does not coin: (see sheet 5)
  - a) Check coin switch connections to the logic board; make sure the coin switch is wired correctly.
  - b) Check U12, pins 3 and 11 for a pulse each time the coin switch is activated. Also, check U11 and U13.
  - c) Check also for the 4 msec. pulses at pin 7 of U10. These pulses serve as timing for the video circuit. Check also pin 5 of U11; pin 6, U13.
  - d) If a game is started only occasionally when a coin is deposited, the coin switch wire may need to be adjusted for a lighter, or heavier, tension.
  - e) If the coin counter does not activate, check U12, pin 3 for a pulse each time the coin switch is activated; also, check Q1 and Q2. (see sheet 5)
4. No  $\emptyset$ 1 clock pulses to the microprocessor: (see sheet 4)
  - a) check for pulses at the crystal, Y1.
  - b) check for pulses at pin 6 of U68; at pin 6 of U49; and at pin 4 of U54.
5. No player control: (see sheet 5)
  - a) make sure the player control connections from the switches to the

## MAINTENANCE PROCEDURES- cont'd.

logic board are intact. Ensure that each switch is connected.

- b) If these are good, check for an output from U1 as you push each switch.

### 6. Random display on the screen:

- a) If the screen shows what appears to be a meaningless display, and it cannot be cleared by activating the coin switch, several different parts of the circuit should be considered:

One or more RAM's, U56 through U63 (sheet 5)

One of the programmed IC's, or EPROM's (sheet 6) Check their sockets.

The reset circuit is not working. (see #1, above)

The microprocessor is bad. (sheet 4)

Data or address bus problem (e.g. U33 or U34, sheet 4, could be bad)

## TRANSFORMER VOLTAGE CONVERSION INSTRUCTIONS:

To convert the game transformer to 100, 115, or 230 VAC, refer to the following chart:

For 100 Volts: Connect the voltage INPUT lines to terminals 1 and 2 on the transformer.

For 115 Volts: Connect the voltage INPUT lines to terminals 1 and 3.

For 230 Volts: Connect the voltage INPUT lines to terminals 1 and 4, with terminal 3 connected to the LAMP circuit.

Also, the TV monitor must be converted to the same voltage input as the game transformer. Refer to the monitor manual included in the game.

**Gremlin Industries, Inc.**  
San Diego, California 92173

**PARTS LIST**

**TITLE**  
TOP ASSY HEAD ON

722-0001  
DWG NO

SH 1  
OF 8

A  
REV

DRAWN G. LLOYD

ENGR

APPR

CHECK

*Steve J. Fay*

REVISION DESCRIPTION

LTR DATE

A RELEASED

3-2-79

DRAFT  
G.LLOYD

CHECK

*J. Fay*

APPR

*J. Fay*

**Gremlin Industries, Inc.**  
San Diego, California 92123

**PARTS LIST**

**TITLE**  
TOP ASSY. HEAD ON

722-0001  
DWG NO

SH 2  
OF 8

A  
REV

ITEM NO	PART NO	QTY PER ASSY			DESCRIPTION	REF DES
1	722-0001	1			TOP ASSY HEAD ON.	
2	130-0001	1			SPEAKER GAME	
3	130-0002	1			SPEAKER COVE	
4	140-0021	1			COVER J-BOX	
5	140-0033	1			CABINET HEAD-ON	
6	200-0002	1			MONITOR 19"	
7	220-0035	1			LOCK	
8	220-0066	2			COIN MECH.	
9	250-0032	1			BEZEL	
10	250-0034	1			SPRING RETAINER	
11	250-0038	1			MOULDING	
12	250-0048	1			CLIP SWITCH	
13	250-0285	1			FRNT. CASH DOOR MOD.	
14	253-0092	1			PANEL MON. SCR.	
15	253-0093	1			PANEL LOGO	
16	280-0004	25			CLIP WIRE	
17	280-0005	5			CABLE TIE	
18	280-0010	2			NUT WIRE	
19	390-0011	1			LAMP FLOR.	
20	390-0012	1			LAMP FIX.	
21	420-0028	1			DECAL SYN	
22	420-0030	1			DECAL CAUTION 115V	
23	420-0038	2			DECAL IMPORTANT NOTE	
24	420-0040	1			DECAL RECYCLE	

**Gremlin Industries, Inc.**  
San Diego, California 92173

**PARTS LIST**

**TITLE**  
TOP ASSY HEAD-ON

722-0001  
DWG NO

SH 3  
OF 8

A  
REV

ITEM NO	PART NO	QTY PER ASSY			DESCRIPTION	REF DES
25	420-0041	1			DECAL 5/11 SM.	
26	420-0060	1			DECAL TIP N TELL	
27	420-0071	1			INST CRATING	
28	420-0116	1			WRAP AROUND SIDE	
29	420-0117	1			TOP COVER	
30	420-0124	4			CORN. STRIP.	
31	420-0158	1			MANUAL WELLS GARDNER.	
32	420-0189	1			GRAPHIC SIDE LEFT	
33	420-0190	1			GRAPHIC SIDE RIGHT	
34	420-0191	1			GRAPHIC INTERIOR.	
35	420-0192	1			DECAL CARTON	
36	420-0193	1			MANUAL HEAD-ON	
37	250-0327	1			BRKT SUPPRT CRT.	
38	807-0009	1			J-BOX	
39	807-0010	1			SPKR HARNESS	
40	815-0020	1			PWR SUPPLY	
41	815-0028	1			COIN MECH HARNESS	
42	822-0001	1			VID LOGIC BD.	
43	822-0002	1			SOUND BD.	
44	822-0004	1			ASSY. CTRL PNL.	
45	822-0005	1			HARNESS CTRL PNL.	
46	822-0006	1			HARNESS PWR./SOUND	
47	822-0007	1			JUMPER HARNESS	
48	822-0008	1			MONITOR HARNESS	
49	822-0010	1			HARNESS COIN CTR.	

**Gremilin Industries, Inc.**  
San Diego, California 92173

**PARTS LIST**

**TITLE**  
TOP ASSY. HEAD-ON

722-0001  
DWG NO

SH 4  
OF 8

A  
REV

ITEM NO	PART NO	QTY PER ASSY			DESCRIPTION	REF DES
50		1			PALET HEAD-ON	
51	220-0008	1			COUNTER DIGITAL	
52						
53		4			SCR PHL PAN HD # 6 X 3/8 SHI MITL	
54		7			SCR, #6 SHI, RD. HD. CRS REC. 1/2 LB	
55						
56		4			SCR, #8 X 1/2 SHI RD. HD PHL	
57		2			NUT HEX # 10-32	
58		4			MACH SCR, #8-32 X 1 1/2 SLOT HD	
59		14			BOLT, CARRIAGE 10-24 X 1 3/4	
60		6			MACH. SCR, #10-32 X 1.0 PHL PAN	
61		6			WASHER, LOCK, SPLIT # 10	
62						
63						
64		4			WASHER, FLAT # 8	
65		12			WASHER, LOCK, SPLIT # 8	
66		12			WASHER, FLAT # 10	
67		6			NUT, HEX # 10-24	
68		12			NUT, HEX # 8-32	
69		8			NUT, WING 10-24	
70		8			8-32 X 3/4 CRS TAMPER PROOF	

**Gremelin Industries, Inc.**  
San Diego, California 92113

**PARTS LIST**

**TITLE**  
CONTROL PANEL ASSY

822-0004  
DWG NO

SH 1  
OF 3  
A  
REV

Sheet 3 of 5

DRAWN G. LORD 12-7-78 ENGR  
CHECK *[Signature]* 12-22-78 APPR

LTR	DATE	REVISION DESCRIPTION	DRAFT	CHECK	APPR
A	12-7-78	INITIAL RELEASE	G. LORD	<i>[Signature]</i>	<i>[Signature]</i>







GREMILIN IND. INC.  
SAN DIEGO CA. 92123

PARTS LIST

TITLE  
ASSY, POWER SUPPLY

815-0020  
DWG NO

SH 2  
OF 3

A  
REV

ITEM NO	PART NO	QTY PER ASSY				DESCRIPTION	REF DES
1	140-0015					1 CHASSIS, POWER SUPPLY	
2	150-0022					1 CAP, 9000UF 12V	
3	211-0005					9 CONN CRIMP LOCK	
4	211-0007					1 CONN, KEY, POLARIZING	
5	211-0017					4 CONN, QUICK, 1/4" FEM	
6	211-0019					2 CONN, SPADE LUG 1/4"	
7	212-0016					1 CONN, FEM 10 PIN	
8	213-0006					1 SOCKET, TO-3	
9	280-0014					4 STAND-OFFS, CLIPS	
10	.280-0056					1 CLAMP, CAP. VR4 1 1/2"	
11	481-0009					1 DIODE, MDA 3500	
12	482-0007					1 XISTOR, 2N3055	
13	560-0003					1 XFMR, MODEL 4-10345B	
14	815-0021					1 POWER SUPPLY ASSY (PCB)	
	815-0020					SHEM. ASSY. PWR. SUPP.	(REFERANCE)
15						5 SCREW-MACH P.HD#6-32 X.5	
16						4 NUT HEX #6-32	
17						4 SCREW-MACH RD, HD#4-40 X.37	
18						4 NUT HEX #4-40	
19						4 RIVET, POP 3/16	
20						4 SCR, MACH, HEX, WAS, HD 1/4-20 X	5/8"
21						1 SCR, MACH, P.HD. #6-32 x 1.0"	

**Greenlin Industries, Inc.**  
San Diego, California 9213

**PARTS LIST**

**TITLE** PC ASSY - POWER SUPPLY

815-0021  
**DWG NO**

SH 1 OF B  
**REV**

ITEM NO	PART NO	QTY PER ASSY		DESCRIPTION	REF DES
1	170-0082		1	PER - POWER SUPPLY	
2	150-0019		2	CAP. E 4700UF, 25V	C5, C6
3	151-0001		1	CAP. CER. .05UF, 50V	C11
4	151-0002		2	CAP. CER 100PF, 50V	C17, C19
5	151-0008		1	CAP. CER. .001UF, 50V	C10
6	151-0011		3	CAP. CER. .01UF, 50V	C12, C14, C16
7	151-0012		1	CAP. CER. .1UF, 50V	C3
8	153-0001		5	CAP. TANT 10UF, 25V	C1, C2, C7, C13, C15
9					
10	212-0003		2	CONN M 10 PIN	
11	212-0004		2	CONN M 4 PIN	
12					
13	313-0001		1	IC LM723	U3
14	313-0004		3	IC LM741EN	U1, U2, U4
15					
16	471-0101		1	RES 100Ω, 1/2W, 5%	R15
17	471-0102		10	RES 1KΩ, 1/2W, 5%	R517, 20, 22, 24, 35, 36, 38, 39
18	471-0103		4	RES 10KΩ, 1/2W, 5%	R1, R14, R21, R37
19	471-0104		1	RES 100KΩ, 1/2W, 5%	R33
20	471-0122		1	RES 1.2KΩ, 1/2W, 5%	R18
21	471-0152		2	RES 1.5KΩ, 1/2W, 5%	R13, R16
22	471-0272		5	RES 2.7KΩ, 1/2W, 5%	R7, R25, R26, R43, R46
23	471-0332		1	RES 3.3KΩ, 1/2W, 5%	R32
24	471-0471		2	RES 470Ω, 1/2W, 5%	R34, 40
25	471-0473		2	RES 47KΩ, 1/2W, 5%	R44, R45

Quantum Electronics, Inc.  
San Diego, California 92161

PARTS LIST

TITLE P<sub>0</sub> ASSY -  
POWER SUPPLY

815-0021  
DWG NO

SH 3  
OF  
REV B

ITEM NO	PART NO	QTY PER ASSY			DESCRIPTION	REF DES
26	471-0562			1	RES 5.6K Ω 1/2W, 5%	R12
27	472-00R5			4	RES 0.5, 1W, 5%	R4, R29-R31
28	473-00R1			1	RES 0.1, 5W, 3%	R28
29						
30	475-0004			1	POT 1K TRIMMER	R9
31	475-0005			2	POT 2K TRIMMER	R8, R42
32						
33	481-0004			4	DIODE MRS01	D1-D4
34	481-0006			2	DIODE 1N914	D7, D8
35	481-0008			1	DIODE ZENER 1N5231	D10
36						
37	482-0006			3	TRANSISTOR 2N4403	Q1, Q3, Q4
38	482-0013			1	TRANSISTOR TIP110	Q6
39	482-0014			2	TRANSISTOR 2N4401	Q2, Q5
40	482-0015			1	TRANSISTOR TIP115	Q7
41	482-0016			2	TRANSISTOR TIP29	Q8, Q9
42						
43	471-0133			1	RES 13K OHMS 1/2W 5%	R41
44						
45	815-0020				REF SCHEMATIC	
46						
47						
48						
49						
50						

**Gremlin Industries, Inc.**  
 San Diego, California 92173

**PARTS LIST**

**TITLE**  
 HEAD ON SOUND

822-0002  
 DWG NO

SH 1  
 OF 6  
 REV B

SHT 5 of 6 "D" SIZE

DRAWN *Wigney* 11-9-78  
 CHECK *Steve Fay* 12-22-78

ENGR  
 APPR

LTR	DATE	REVISION DESCRIPTION	DRAFT	CHECK	APPR
A	1-8-79	RELEASED	WJB	<i>[Signature]</i>	<i>[Signature]</i>
B	1-25-79	ECN 273 ADDENDUM 273 2-12-79	KB	<i>[Signature]</i>	<i>[Signature]</i>

**Greenlin Industries, Inc.**  
San Diego, California 92123

**PARTS LIST**

**TITLE**  
HEAD ON SOUND

B22-0002  
DWG NO

SH 2  
OF 6

REV B

ITEM NO	PART NO	QTY PER ASSY		DESCRIPTION	REF DES
1					
2	151-0011	6		CAP CER .01 $\mu$ f 50V	C8,13,17,32,21,22
3	151-0012	4		CAP CER .1 $\mu$ f 50V	C5,C12,C26,C27
4	152-0001	3		CAP FILM .1 $\mu$ f 100V	C31,C20,C25
5					
6	152-0012	3		CAP FILM .047 $\mu$ f 200V	C2,C23,C24
7	152-0018	3		CAP FILM .01 $\mu$ f 250V	C3,C6,C19
8	152-0020	3		CAP FILM .47 $\mu$ f 100V	C1,C18,C16
9	153-0001	7		CAP TANT 10 $\mu$ f 25V	C10,C11,C28-C30,C33,C34
10	153-0002	2		CAP TANT 1 $\mu$ f 25V	C4,C9
11	153-0003	2		CAP TANT 2.2 $\mu$ f 25V	C14,15
12	153-0004	1		CAP TANT 4.7 $\mu$ f 25V	C7
13	170-0154	1		PCB HEAD ON SOUND	
14	212-0031	1		CONN M 12 PIN	P1
15	313-0004	1		IC LM741 EN DIP	U3
16	313-0008	1		IC LM348 DIP	U1
17	314-0001	5		IC NE555 DIP	U2,U4,U9,U12,U14
18	315-0005	4		IC 4013	U5-U8
19	315-0009	1		IC 4081	U11
20	315-0035	1		IC MM5837	U13
21	315-0043	1		IC 4069	U10

**Gremlin Industries, Inc.**  
San Diego, California 92123

**PARTS LIST**

**TITLE**  
HEAD ON SOUND

822-0002  
DWG NO

SH 3  
OF 6  
REV B

ITEM NO	PART NO	QTY PER ASSY		DESCRIPTION	REF DES
22	471-0101	2		RES 100 OHM 1/2W 5%	R23, R32
23	471-0102	10		RES 1K OHM 1/2W 5%	R4, R5, R8, R14, R22, R35, R45, R55, R72, R48
24	471-0103	16		RES 10K OHM 1/2W 5%	R10, R12, R13, R25, R43, R46, R50, R56, R60, R64, R67, R68, R75
25	471-0104	17		RES 100K OHM 1/2W 5%	R15, R21, R24, R34, R38, R41, R42, R62, R65, R69, R71, R76
26	471-0105	3		RES 1 MEG OHM 1/2W 5%	R3, R70, R77
27	471-0124	4		RES 120K OHM 1/2W 5%	R47, R51, R63, R66
28	471-0153	2		RES 15K OHM 1/2W 5%	R1, R2
29	471-0154	1		RES 150K OHM 1/2W 5%	R39
30	471-0220	1		RES 22 OHM 1/2W 5%	R49
31	471-0224	1		RES 220K OHM 1/2W 5%	R40
32	471-0394	8		RES 390K OHM 1/2W 5%	R26, R31, R44, R73
33	471-0472	3		RES 4.7K OHM 1/2W 5%	R36, R52, R74
34	471-0473	1		RES 47K OHM 1/2W 5%	R33
35	471-0474	2		RES 470K OHM 1/2W 5%	R9, R11
36	471-0682	2		RES 6.8K OHM 1/2W 5%	R53, R54
37	475-0006	2		POT 100K	R6, R7
38	481-0006	8		DIODE IN914 / IN4148	D1 - D8





**Gromlin Industries, Inc.**  
San Diego, California 92123

**PARTS LIST**

**TITLE ASSEMBLY**  
C. V. LOGIC BD.

822-0001  
DWG NO

SH 1  
OF 6  
REV A

SHT 3 "E" SIZE  
SHT 4,5,6 "D" SIZE

**DRAWN** *W. J. [Signature]* 11-20-78  
**CHECK** *[Signature]* 12-22-78

ENGR  
APPR

**LTR DATE**

**REVISION DESCRIPTION**

**DRAFT**

**CHECK**

**APPR**



**Granville Industries, Inc.**  
San Diego, California 92123

**PARTS LIST**

**TITLE**  
ASSY BASIC V.I.C. BD.

800-0031  
**DWG NO**

SH 1  
OF 5  
REV A

SHT 5 "E" SIZE

**DRAWN** *Wynona* 11-20-78  
**CHECK** *Steve J. Fay* 12-22-78

**ENGR**  
**APPR**

**DRAFT**  
WJB

**CHECK**  
*WJB*

**APPR**  
*WJB*

**LTR DATE**  
A 12-22-79

RELEASED

**REVISION DESCRIPTION**

Growth Industries, Inc.  
San Diego, California 92161

PARTS LIST

TITLE  
ASSY BASIC W.C.BD.

800-0031  
DWG NO

SH 2  
OF 5  
REV A

ITEM NO	PART NO	QTY PER ASSY			DESCRIPTION	REF DES
1	151-0005	1			CAP CER 680 <sup>pf</sup> 50V	C39
2	151-0012	54			CAP CER .1 <sup>pf</sup> 50V	C3,5,7-11,13-17,22,25, C27-38,C40-67
3	152-0001	1			CAP FILM .1 <sup>pf</sup> 100V	C4
4	152-0017	1			CAP FILM .33 <sup>pf</sup> 100V	C24
5	153-0001	6			CAP TANT 10 <sup>pf</sup> 25V	C12,20,21,23,26,68
6	153-0002	1			CAP TANT 1 <sup>pf</sup> 25V	C19
7	170-0150	1			PCB C.V. LOGIC	
8	211-0004	6			CONN PIN TEST PT	TP1-TP4, GND
9	212-0004	2			CONN M 4 PIN	
10	212-0021	3			CONN M 10 PIN	
11	212-0031	1			CONN M 12 PIN	
12	213-0001	6			SKT 24 PIN DUAL INLN	XU22-XU27
13	213-0004	12			SKT 16 PIN DUAL INLN	XU33,XU34,XU56-XU63, XU65,XU66
14	213-0005	2			SKT 40 PIN DUAL INLN	XU48,XU53
15	213-0008	3			SKT 20 PIN DUAL INLN	XU1,XU16,XU19
16	230-0009	1			XTAL CLK 15.46848	Y1
17	313-0023	1			IC 320T-5.0	U73
18	314-0001	2			IC NE 555	U10,U55

**Granulation Industries, Inc.**  
San Diego, California 92123

**PARTS LIST**

**TITLE**  
ASSY BASIC V.I.C.B.D.

800-0031  
DWG NO

SH 3  
OF 5

A  
REV

ITEM NO	PART NO	QTY PER ASSY		DESCRIPTION	REF DES
19	314-0015	1		1C 7404	U54
20	314-0018	3		1C 74LS00	U4, U12, U32
21	314-0019	2		1C 74LS04	U35, U64
22	314-0040	3		1C 74LS125	U13, U46, U47
23	314-0046	1		1C 74504	U68
24	314-0053	4		1C 74 5175	U49-U51, U67
25	314-0055	2		1C 74LS244	U1, U19
26	314-0058	5		1C 74LS08	U37-U39, U41, U71
27	314-0059	1		1C 74LS10	U52
28	314-0061	1		1C 74LS42	U40
29	314-0062	2		1C 74LS74	U11, U72
30	314-0078	1		1C 74LS02	U36
31	314-0092	2		1C 8216	U33, U34
32	315-0039	8		1C 4K RAM 12V	U56-U63
33	315-0031	1		1C Z80 MK3880	U53
34	315-0042	1		1C VID INTERFACE	U48
35	314-0093	1		1C 74LS374	U16
36	316-0042	1		1C PROM 32X8 5EQ	U66
37	316-0043	1		1C PROM 32X8 CTL	U65
38	390-0003	1		LED RED	D4
39	471-0011	1		RES 10 OHM 1/2W 5%	R50
40	471-0102	7		RES 1K OHM 1/2W 5%	R7-R11, R32, R37
41	471-0103	1		RES 10K OHM 1/2W 5%	R6

Greenhill Industries, Inc.  
San Diego, California 92121

PARTS LIST

TITLE  
ASSY BASIC V.I.C.B.D.

800-0031  
DWG NO

SH 4  
OF 5

A  
REV

ITEM NO	PART NO	QTY PER ASSY				DESCRIPTION	REF DES
42	471-0104	3				RES 100K OHM 1/2W 5%	R42-R44
43	471-0222	6				RES 2.2K OHM 1/2W 5%	R20-R25
44	471-0223	1				RES 22K OHM 1/2W 5%	R3
45	471-0331	6				RES 330 OHM 1/2W 5%	R30,R31,R33,R34,R45, R46
46	471-0471	1				RES 470 OHM 1/2W 5%	R49
47	471-0472	3				RES 4.7K OHM 1/2W 5%	R5,R47,R48
48	471-0750	1				RES 75 OHM 1/2W 5%	R41
49	475-0001	1				POT 10K PC MTV	R4
50	477-0002	2				RES PACK 15X2.2K	RP1,RP3
51	481-0006	3				DIODE 1N914/1N4148	D1,D2,D5
52	482-0006	1				XSTR 2N4403	Q6
53	482-0010	1				XSTR PE8050	Q2
54	482-0014	4				XSTR 2N4401	Q1,Q7,Q10,Q11
55	530-0006	1				HEATSINK 295-1	

REVISIONS				
ZONE	LTR	DESCRIPTION	DATE	APPROVED
A	RELEASED		S.M 3-2-79	

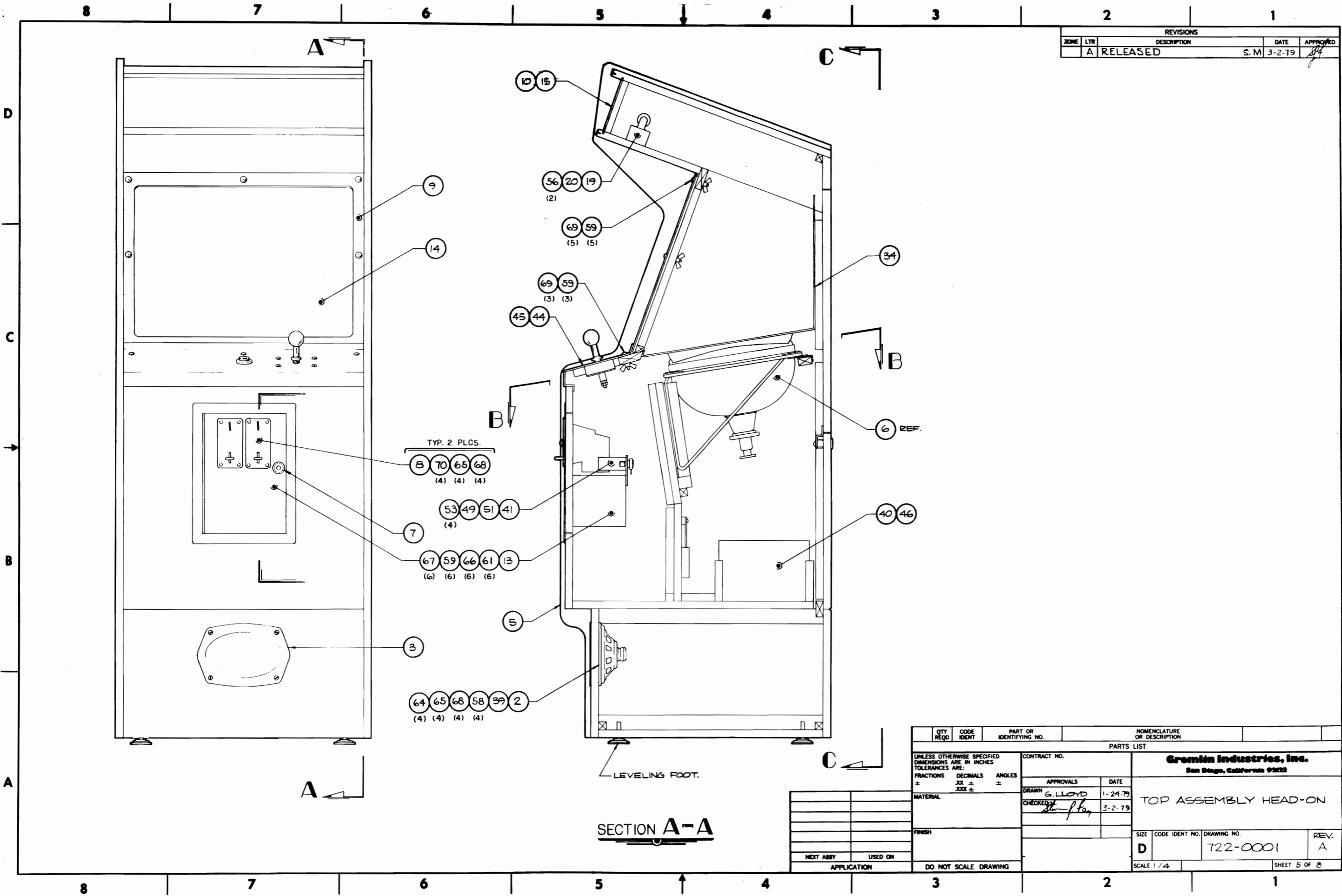

TYP. 2 PLCS.

LEVELING FOOT.

**SECTION A-A**

QTY REQD	CODE IDENT	PART OR IDENTIFYING NO.	NOMENCLATURE OR DESCRIPTION	
PARTS LIST				
UNLESS OTHERWISE SPECIFIED DIMENSIONS ARE IN INCHES TOLERANCES ARE:			CONTRACT NO.	
FRACTIONS	DECIMALS	ANGLES	APPROVALS	DATE
±	XX ±	±		
	XXX ±			
MATERIAL			DRAWN G. LLOYD 1-24-79	
			CHECKED <i>[Signature]</i> 3-2-79	
FINISH				
			SIZE CODE IDENT NO. DRAWING NO. REV.	
			D 722-0001 A	
DO NOT SCALE DRAWING			SCALE 1/4 SHEET 5 OF 8	

APPLICATION	USED ON	NEXT ASSY

722-0001



REVISIONS				
ZONE	LTR	DESCRIPTION	DATE	APPROVED
A		RELEASED	S.M. 3-2-79	<i>[Signature]</i>

8 7 6 5 4 3 2 1

D  
C  
B  
A

D  
C  
B  
A

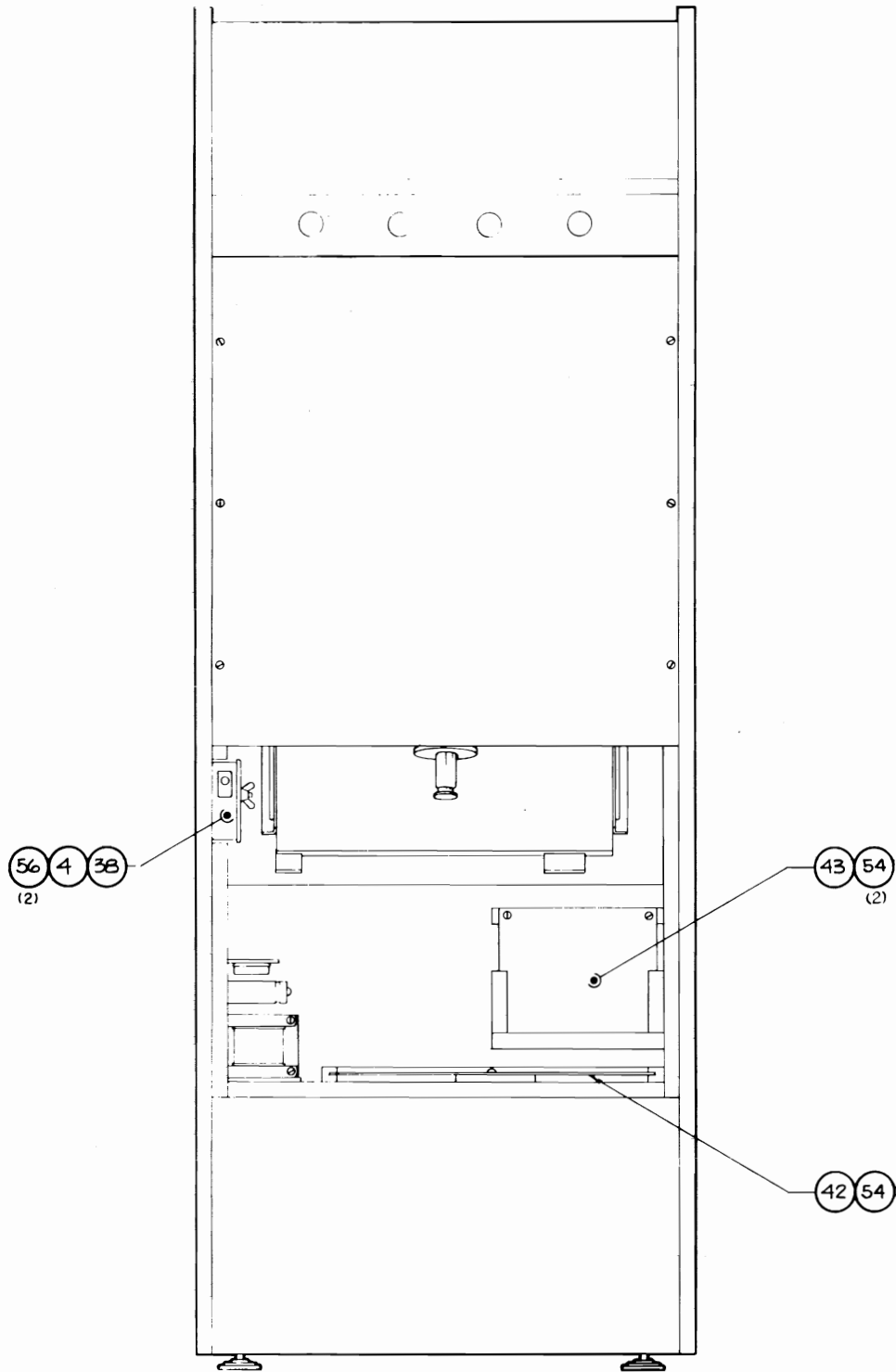

VIEW C-C

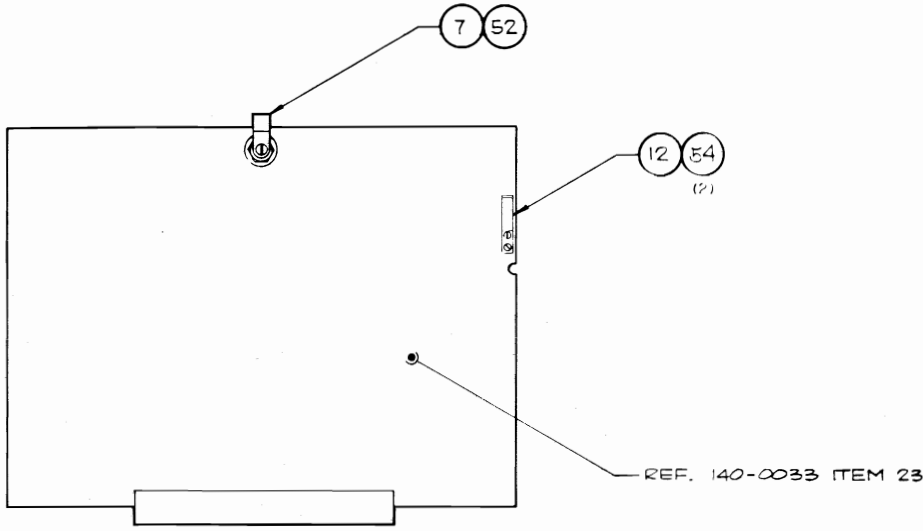

REAR DOOR

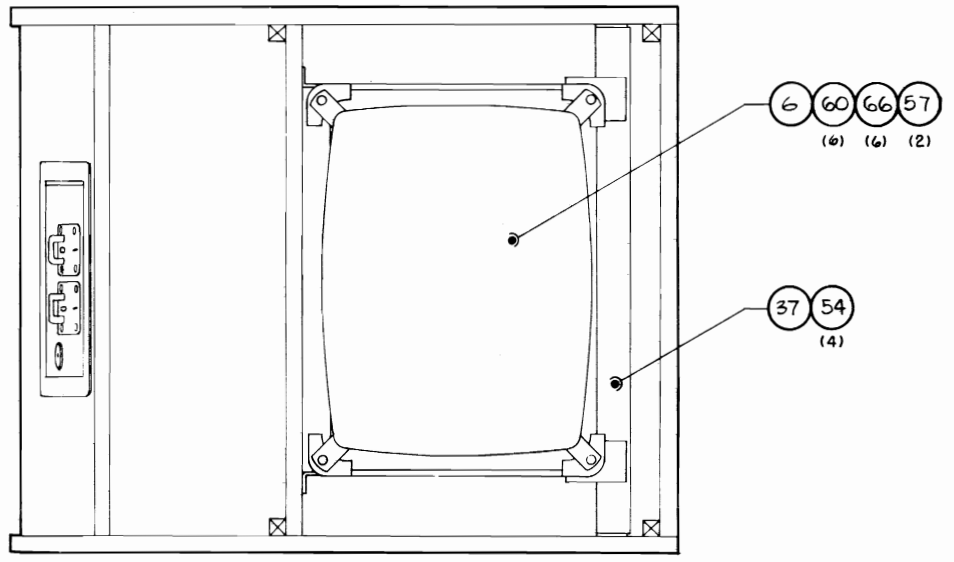

SECTION B-B

QTY REQD	CODE IDENT	PART OR IDENTIFYING NO.	NOMENCLATURE OR DESCRIPTION
PARTS LIST			
UNLESS OTHERWISE SPECIFIED DIMENSIONS ARE IN INCHES TOLERANCES ARE:		CONTRACT NO.	
FRACTIONS	DECIMALS	ANGLES	<b>Grenin Industries, Inc.</b> San Diego, California 92123
±	.XX ±	±	
	.XXX ±		
MATERIAL		APPROVALS	DATE
FINISH		DRAWN <i>G. LLOYD</i>	1-26-79
NEXT ASSY		CHECKED <i>[Signature]</i>	3-2-79
USED ON		TOP ASSEMBLY HEAD-ON	
APPLICATION		SIZE	CODE IDENT NO.
DO NOT SCALE DRAWING		D	722-0001
		SCALE 1/4"	DRAWN. A
		SHEET 6 OF 8	

8 7 6 5 4 3 2 1

REVISIONS				
ZONE	LTR	DESCRIPTION	DATE	APPROVED
A		RELEASED	S.M. 3-2-79	<i>[Signature]</i>

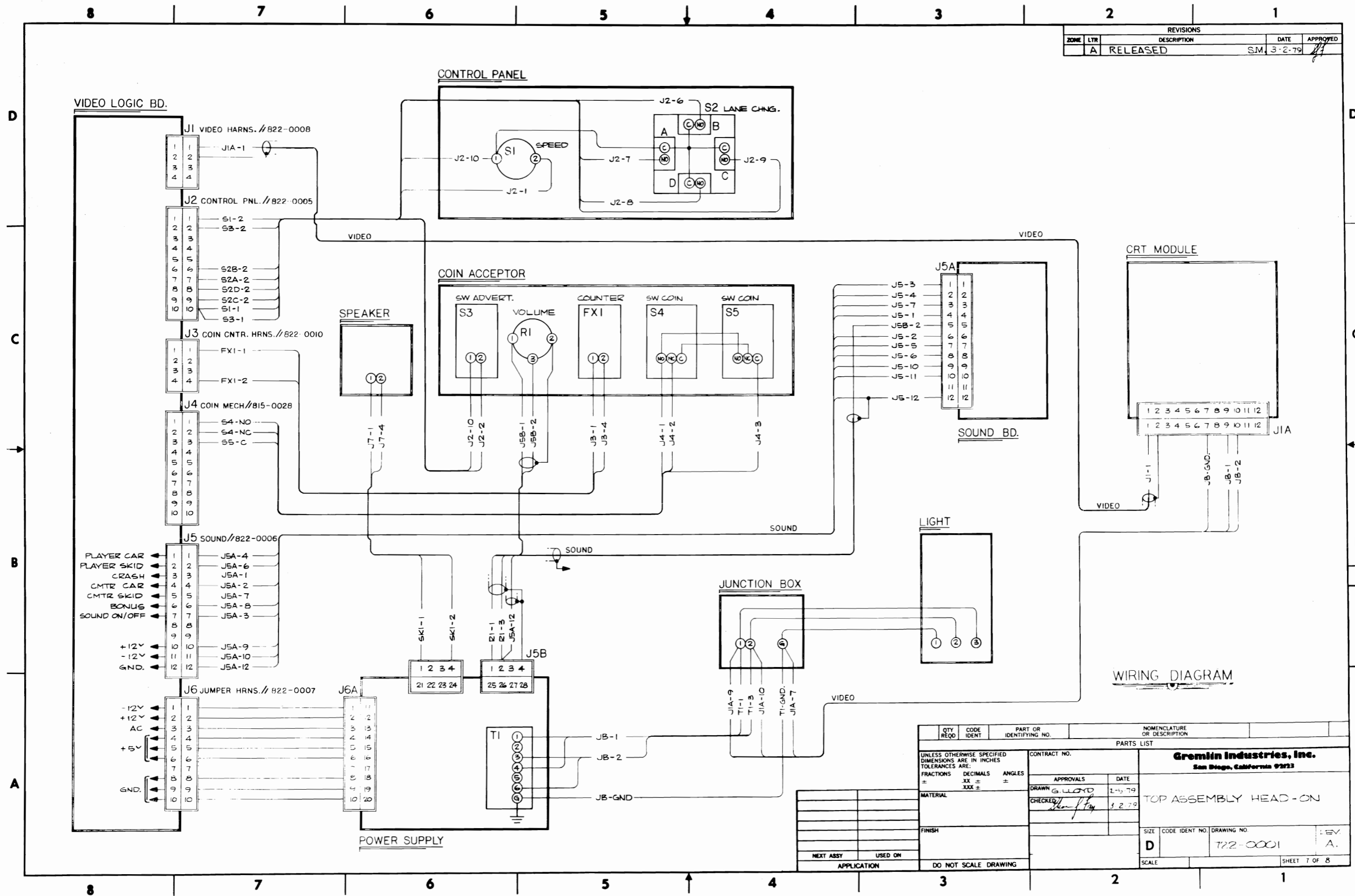

WIRING DIAGRAM

QTY REQD	CODE IDENT	PART OR IDENTIFYING NO.	NOMENCLATURE OR DESCRIPTION
PARTS LIST			
UNLESS OTHERWISE SPECIFIED DIMENSIONS ARE IN INCHES TOLERANCES ARE:		CONTRACT NO.	
FRACTIONS	DECIMALS	ANGLES	
±	.XX ±	±	
	.XXX ±		
MATERIAL		APPROVALS	DATE
FINISH		<i>G. Lloyd</i>	2-5-79
NEXT ASSY		CHECKED	3-2-79
USED ON		TOP ASSEMBLY HEAD-ON	
APPLICATION		SIZE	CODE IDENT NO. DRAWING NO.
DO NOT SCALE DRAWING		D	722-0001
		SCALE	LEV. A.
		SHEET 7 OF 8	

**Gremlin Industries, Inc.**  
San Diego, California 92123

REVISIONS				
ZONE	LTR	DESCRIPTION	DATE	APPROVED
A		RELEASED	S.M. 3-2-79	<i>[Signature]</i>

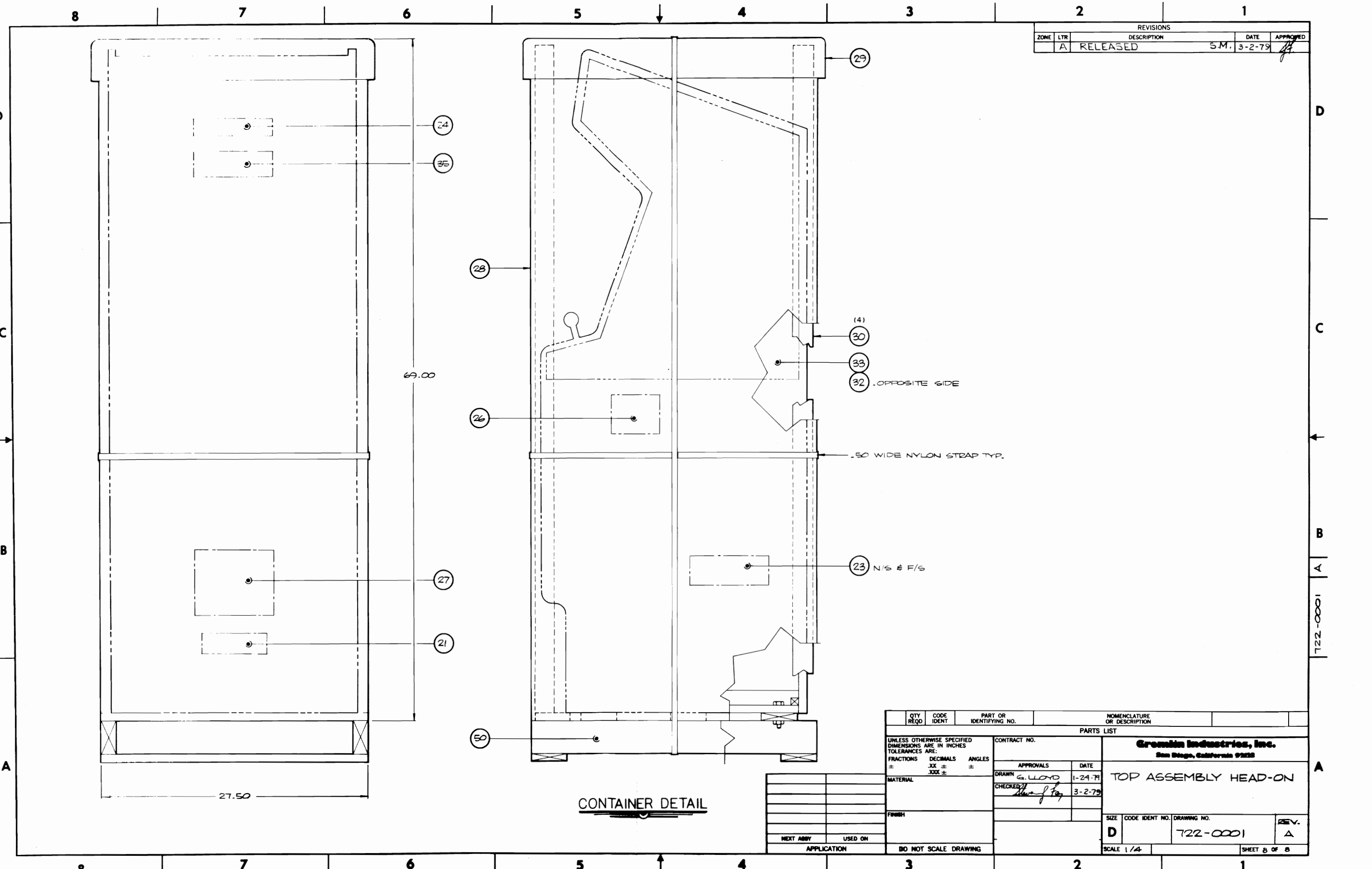

**CONTAINER DETAIL**

QTY REQD	CODE IDENT	PART OR IDENTIFYING NO.	NOMENCLATURE OR DESCRIPTION	
PARTS LIST				
UNLESS OTHERWISE SPECIFIED DIMENSIONS ARE IN INCHES TOLERANCES ARE:		CONTRACT NO.		
FRACTIONS	DECIMALS	ANGLES	<b>Grenin Industries, Inc.</b> San Diego, California 92128	
±	.XX ±	±		
MATERIAL	FINISH	APPROVALS	DATE	<b>TOP ASSEMBLY HEAD-ON</b>
		DRAWN <i>G. LOYD</i> 1-24-79 CHECKED <i>[Signature]</i> 3-2-79		
NEXT ASSY	USED ON	APPLICATION	SCALE 1/4	SIZE <b>D</b> CODE IDENT NO. <b>722-0001</b> DRAWING NO. <b>722-0001</b> REV. <b>A</b>
DO NOT SCALE DRAWING			SHEET 8 OF 8	

722-0001

8 7 6 5 4 3 2 1

REVISIONS				
ZONE	LTR	DESCRIPTION	DATE	APPROVED

D  
C  
B  
A

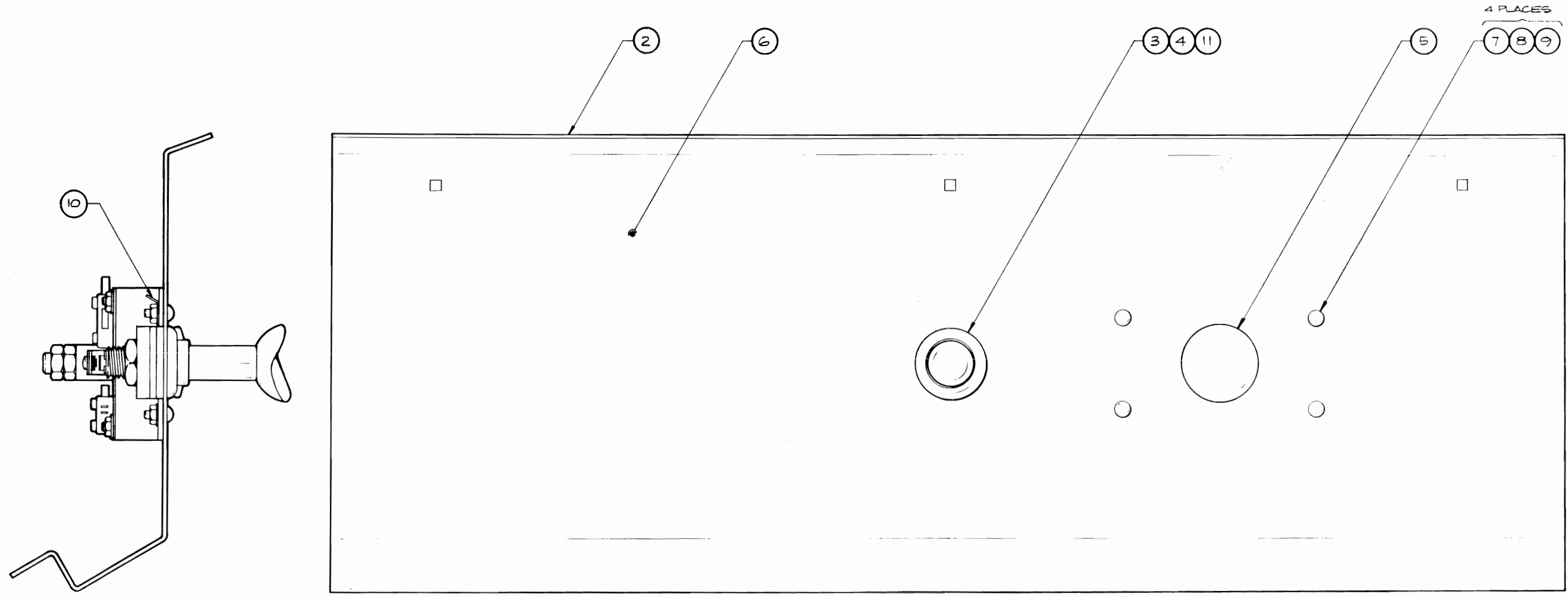

ASSY (ITEM 1)

QTY REQD	CODE IDENT	PART OR IDENTIFYING NO.	NOMENCLATURE OR DESCRIPTION	
			PARTS LIST	
UNLESS OTHERWISE SPECIFIED DIMENSIONS ARE IN INCHES TOLERANCES ARE:		CONTRACT NO.		<b>Gremlin Industries, Inc.</b> San Diego, California 92123
FRACTIONS	DECIMALS	ANGLES	APPROVALS	
±	.XX ±	±	DRAWN <i>G LLOYD</i>	12.7.78
±	.XXX ±	±	CHECKED <i>[Signature]</i>	12.22.78
MATERIAL		FINISH		SIZE
SEE PARTS LIST.				D
NEXT ASSY		USED ON		CODE IDENT NO.
APPLICATION		DO NOT SCALE DRAWING		822-0004
				DRAWING NO.
				A
				SCALE 1/1
				SHEET 3 OF 3

8 7 6 5 4 3 2 1

D  
C  
B  
A

822-0004

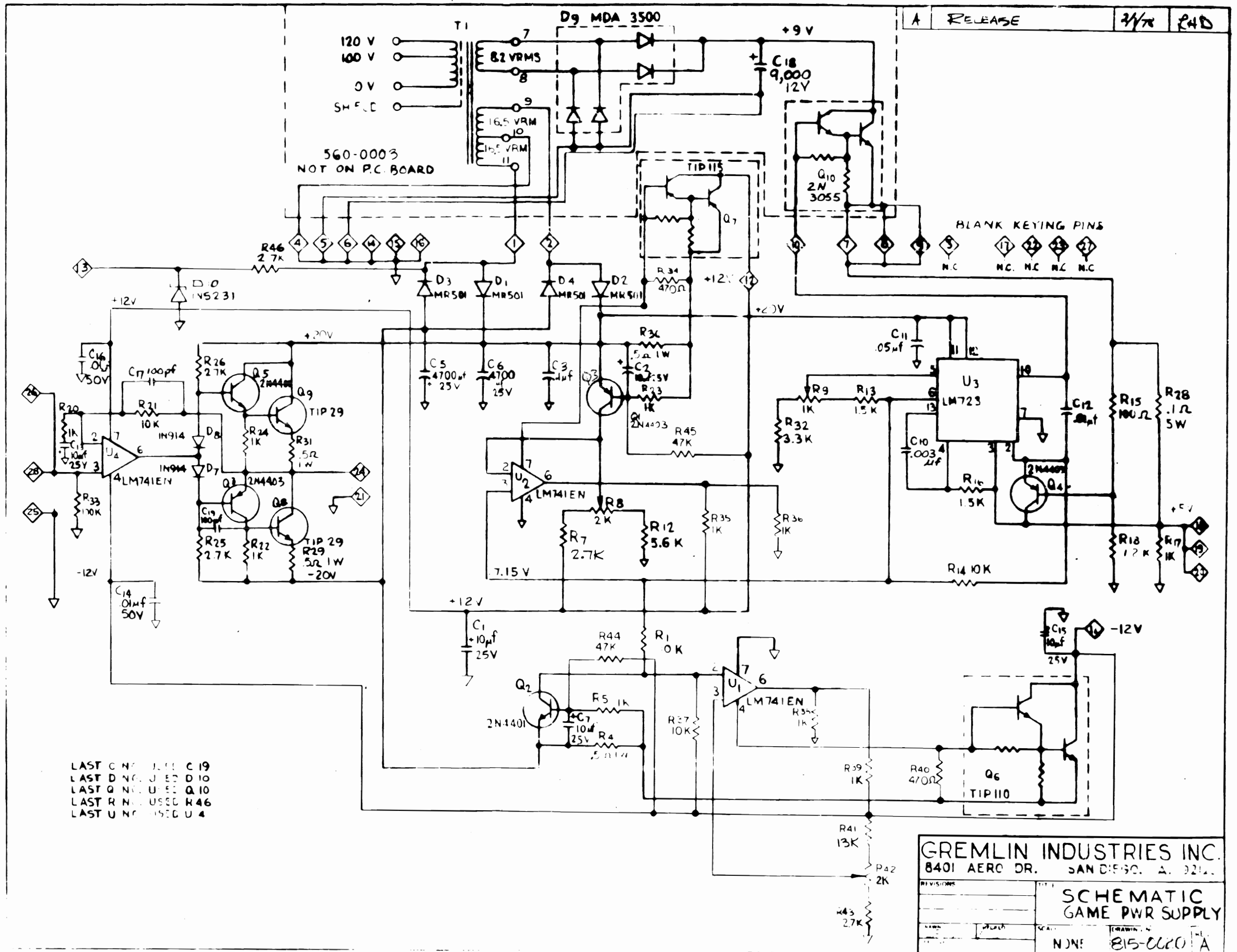

LAST C N C U SEC C 19  
 LAST D N C U SEC D 10  
 LAST Q N C U SEC Q 10  
 LAST R N C U SEC R 46  
 LAST U N C U SEC U 4

A RELEASE 2/78 R4D

**GREMLIN INDUSTRIES INC.**  
 8401 AERO DR. SAN DIEGO, CA 92121  
 REVISIONS: \_\_\_\_\_ TITLE: SCHEMATIC  
 GAME PWR SUPPLY  
 NAME: \_\_\_\_\_ SCALE: \_\_\_\_\_ DRAWING NO: NJN: 815-0020 A  
 SHEET 4

4 3 2 1

REVISIONS				
ZONE	LTR	DESCRIPTION	DATE	APPROVED

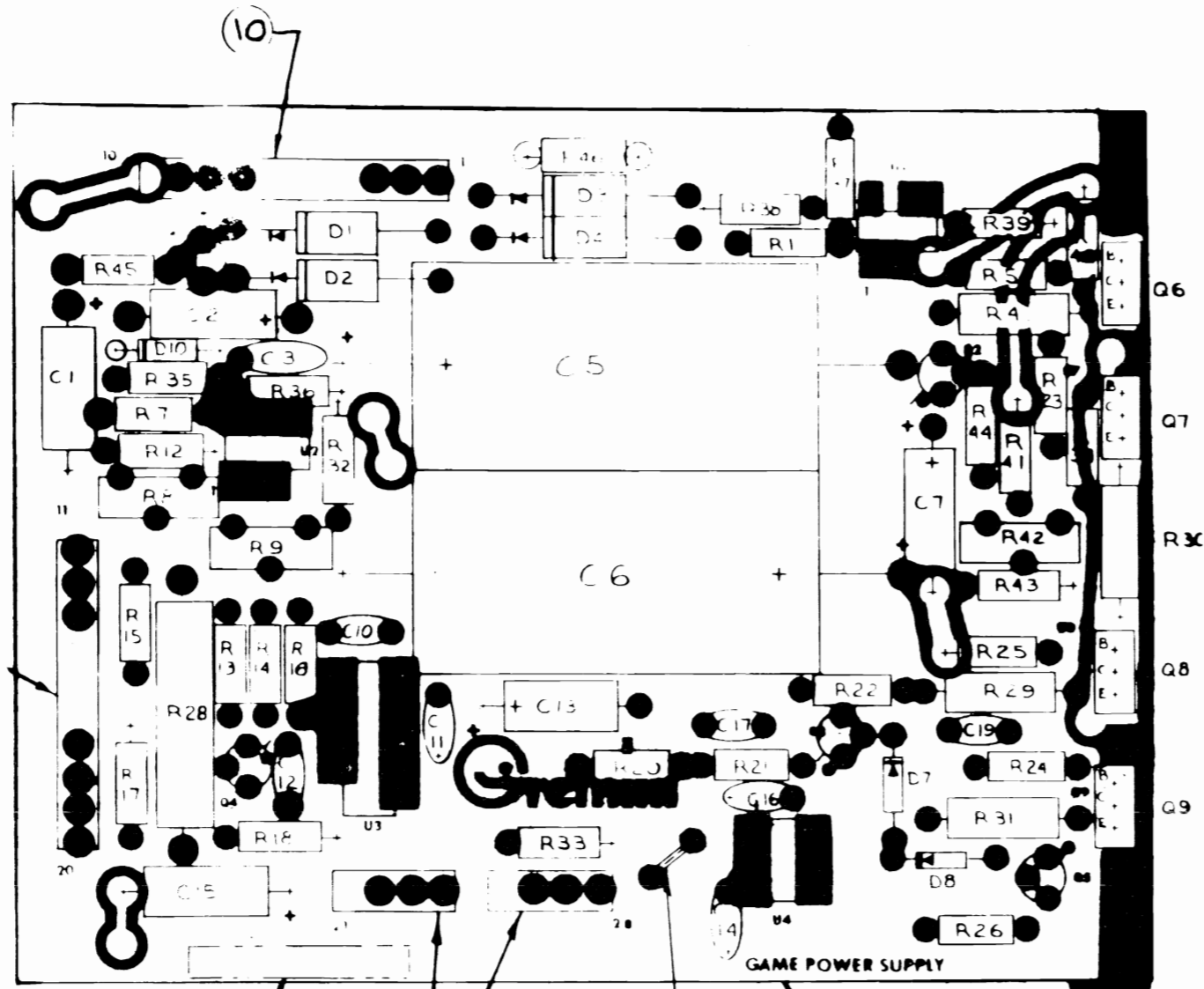

D  
C  
B  
A

D  
C  
B  
A

— REIDENTIFY ASSY WITH No. 815-0021 & LATEST REV

JUMPER (1)

QTY REQD	CODE IDENT	PART OR IDENTIFYING NO	NOMENCLATURE OR DESCRIPTION
PARTS LIST			
UNLESS OTHERWISE SPECIFIED DIMENSIONS ARE IN INCHES TOLERANCES ARE		CONTRACT NO	
FRACTIONS	DECIMALS	ANGLES	<b>Greskin Industries, Inc.</b> San Diego, California 92108  PC ASSY - POWER SUPPLY
-	XX =	=	
MATERIAL		APPROVALS	DATE
FINISH		DRAWN <i>E. LeBlanc</i>	6/24/78
NEXT ASSY		CHECKED <i>[Signature]</i>	7/1/78
APPLICATION		SIZE	CODE IDENT NO
B15-0020	PWR SPLY ASSY	C	815-0021
DO NOT SCALE DRAWING		DRAWING NO	A REV
		SCALE	SHEET 4 OF

4 3 2 1

REVISIONS				
ZONE	LTR	DESCRIPTION	DATE	APPROVED

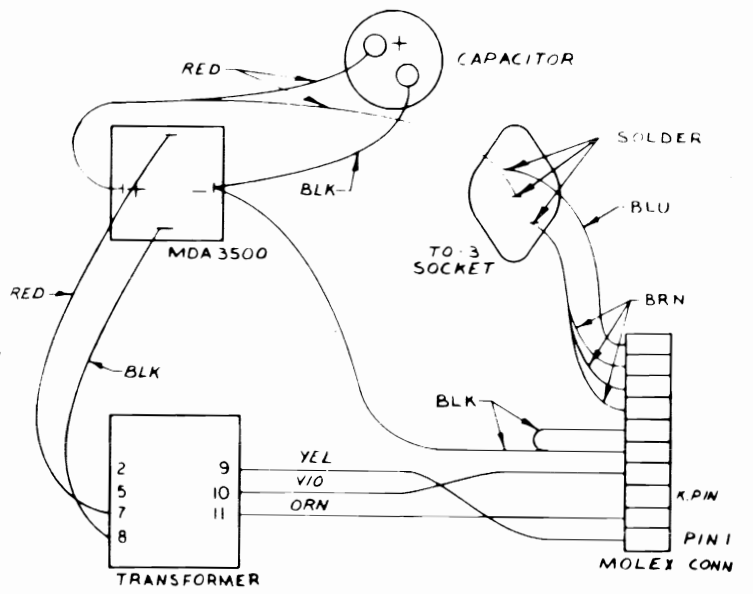
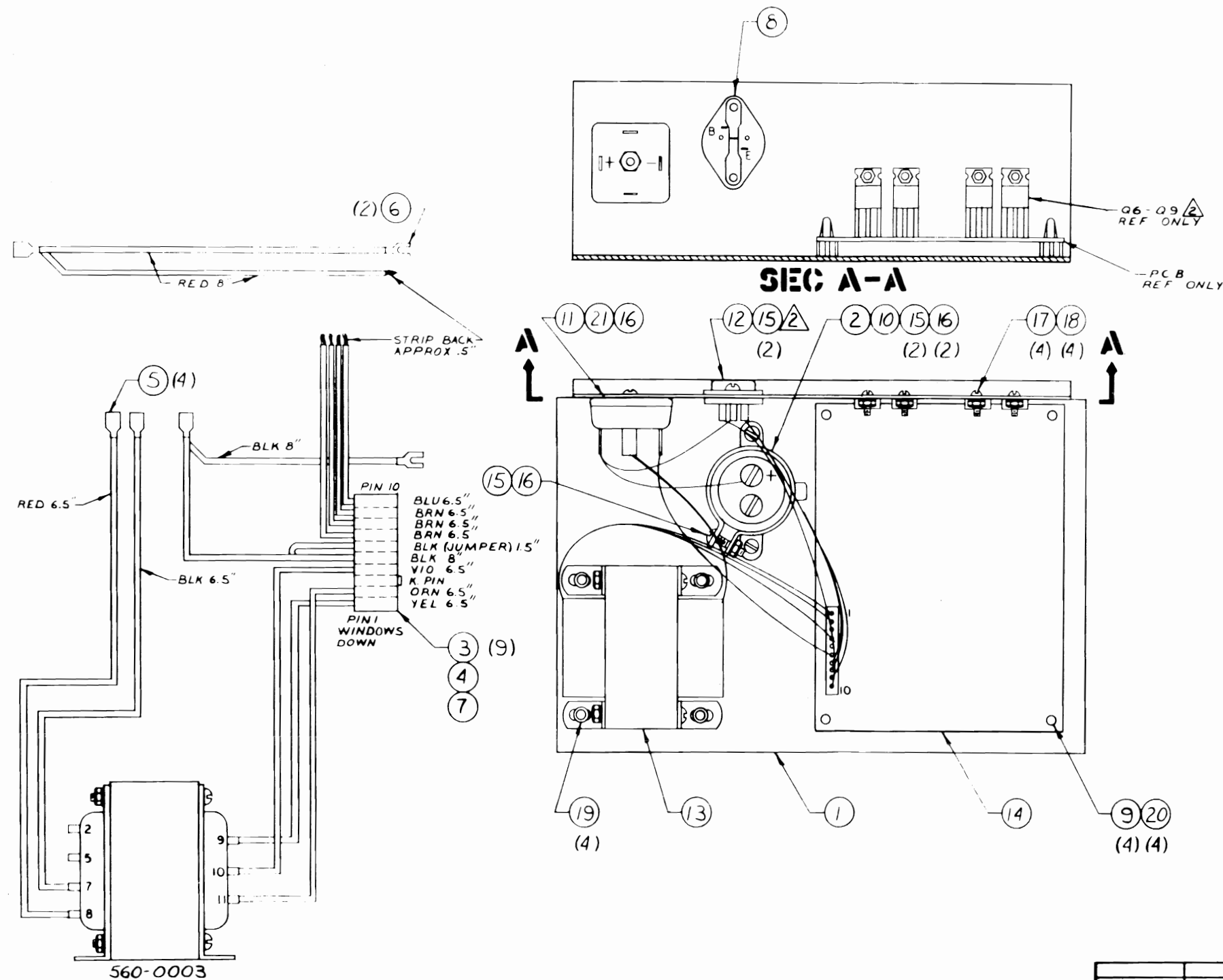

WIRING DIAGRAM

△ ALL POWER TRANSISTORS TO BE MOUNTED WITH HEAT SINKING PASTE & INSULATING HARDWARE  
 1. ALL WIRE TO BE AWG #22 GA  
 NOTES: UNLESS OTHERWISE SPECIFIED

SEE DETACHED PARTS LIST 815-0020

QTY REQD	CODE IDENT	PART OR IDENTIFYING NO.	NOMENCLATURE OR DESCRIPTION
PARTS LIST			
UNLESS OTHERWISE SPECIFIED DIMENSIONS ARE IN INCHES TOLERANCES ARE:		CONTRACT NO.	
FRACTIONS	DECIMALS	ANGLES	<b>Green Industries, Inc.</b> San Diego, California 92108 <b>ASSY POWER SUPPLY</b>
±	JR ±	*	
MATERIAL		APPROVALS	DATE
FINISH		CHECKED <i>Lee J L, pnd</i> DATE	
715-0001	SAFARI	SIZE CODE IDENT NO. DRAWING NO. REV D 815-0020 A	
TEST Assy	USED ON	SCALE FULL SHEET 3 OF 4	
APPLICATION		DO NOT SCALE DRAWING	

815-0020

REVISIONS				
ZONE	LTR	DESCRIPTION	DATE	APPROVED
	A	RELEASED	1-8-79	<i>[Signature]</i>
	B	ECN 273 1-25-79 ADDENDUM 273	1-25-79	<i>[Signature]</i>

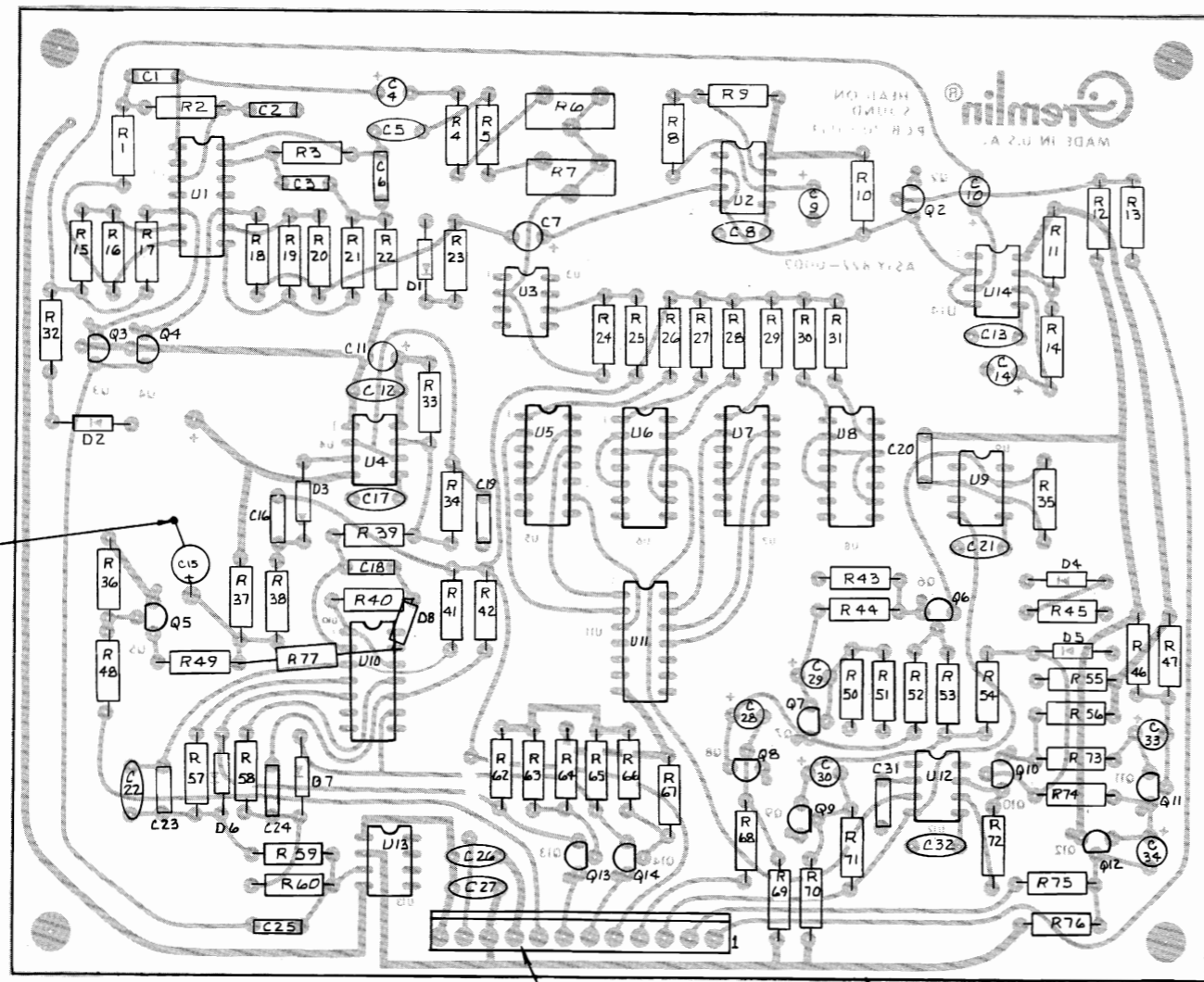

SEE DETACHED PARTS LIST

QTY REQD	CODE IDENT	PART OR IDENTIFYING NO.	NOMENCLATURE OR DESCRIPTION
PARTS LIST			
UNLESS OTHERWISE SPECIFIED DIMENSIONS ARE IN INCHES TOLERANCES ARE:		CONTRACT NO.	
FRACTIONS ±	DECIMALS .XX ±	ANGLES ±	<b>Gremlin Industries, Inc.</b> San Diego, California 92123
	.XXX ±		
MATERIAL	FINISH	APPROVALS	DATE
		<i>[Signature]</i>	11-10-78
		<i>[Signature]</i>	12-22-78
722-0001 HEAD ON			
NEXT ASSY	USED ON		
APPLICATION	DO NOT SCALE DRAWING		
		SIZE	CODE IDENT NO. DRAWING NO.
		D	B22-0002 B
		SCALE 2/1	SHEET 5 OF 6

B22-0002B



REVISIONS				
ZONE	LTR	DESCRIPTION	DATE	APPROVED

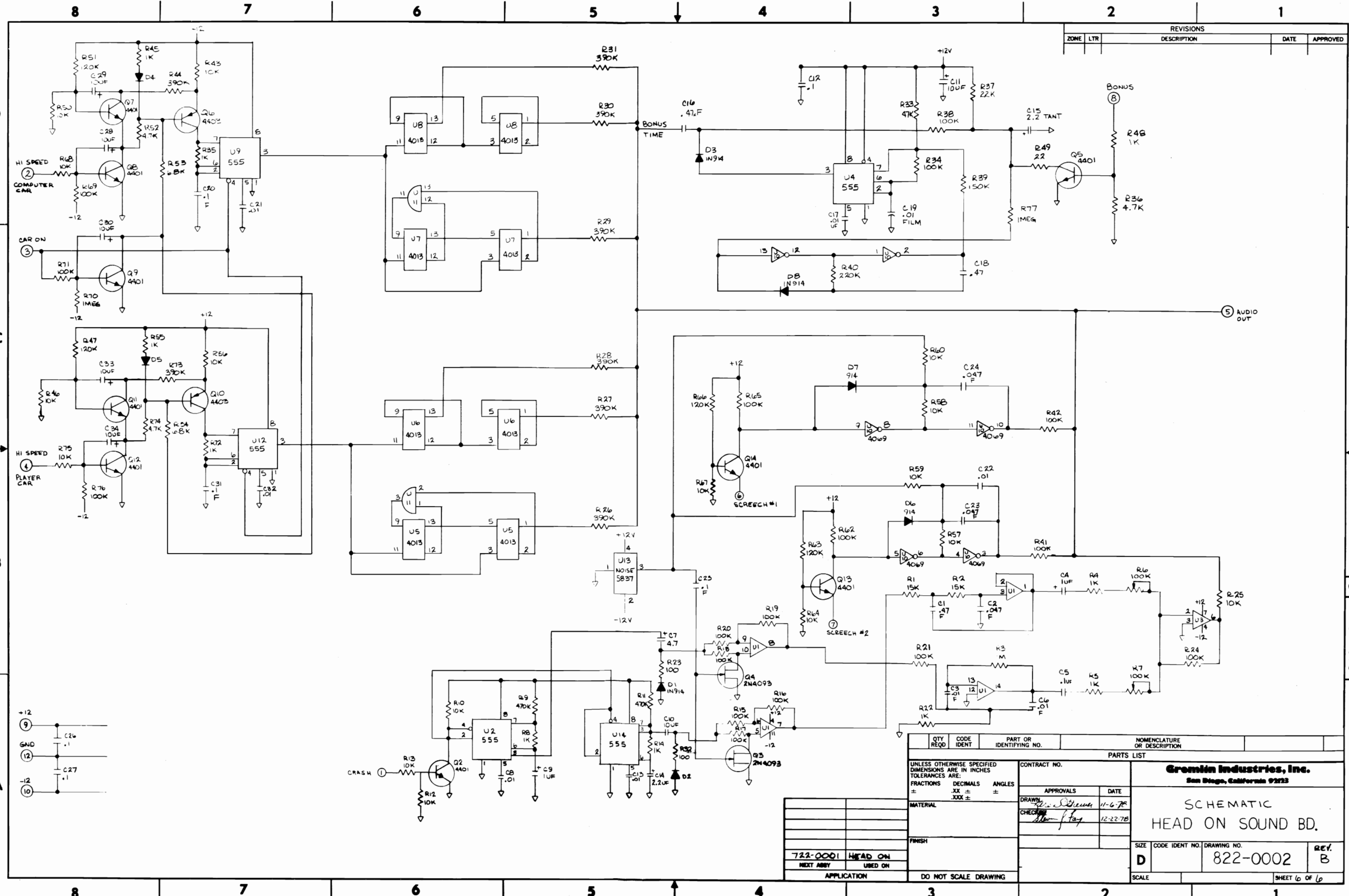

QTY REQD	CODE IDENT	PART OR IDENTIFYING NO.	NOMENCLATURE OR DESCRIPTION
PARTS LIST			
UNLESS OTHERWISE SPECIFIED DIMENSIONS ARE IN INCHES TOLERANCES ARE:		CONTRACT NO.	
FRACTIONS	DECIMALS	ANGLES	APPROVALS
±	±	±	DATE
±	±	±	
MATERIAL		DRAWN: <i>[Signature]</i> 11-6-78	
FINISH		CHECKED: <i>[Signature]</i> 12-22-78	
722-0001 HEAD ON		SIZE CODE IDENT NO. DRAWING NO.	
NEXT ASSY USED ON		D 822-0002	
APPLICATION		SCALE	
DO NOT SCALE DRAWING		SHEET 6 OF 6	

**Gremm Industries, Inc.**  
San Diego, California 92123

SCHEMATIC  
HEAD ON SOUND BD.

822-0002 B

A



2

SEE DETACHED PARTS LIST

QTY REQD	CODE IDENT	PART OR IDENTIFYING NO.	NOMENCLATURE OR DESCRIPTION
PARTS LIST			
UNLESS OTHERWISE SPECIFIED DIMENSIONS ARE IN INCHES TOLERANCES ARE:		CONTRACT NO. <b>Grenin Industries, Inc.</b> San Diego, California 92123	
FRACTIONS	DECIMALS	ANGLES	APPROVALS DATE
XX	XX	XX	11-18-78
XXX	XXX	XXX	CHECKED BY DATE
			12-22-78
MATERIAL		DRAWN BY	
FINISH		CHECKED BY	
NEXT ASSY USED ON		DRAWING NO.	
722-000 / HEAD ON		822-0001	
DO NOT SCALE DRAWING		SCALE 2/1	
		SHEET 3 OF 6	

2

1

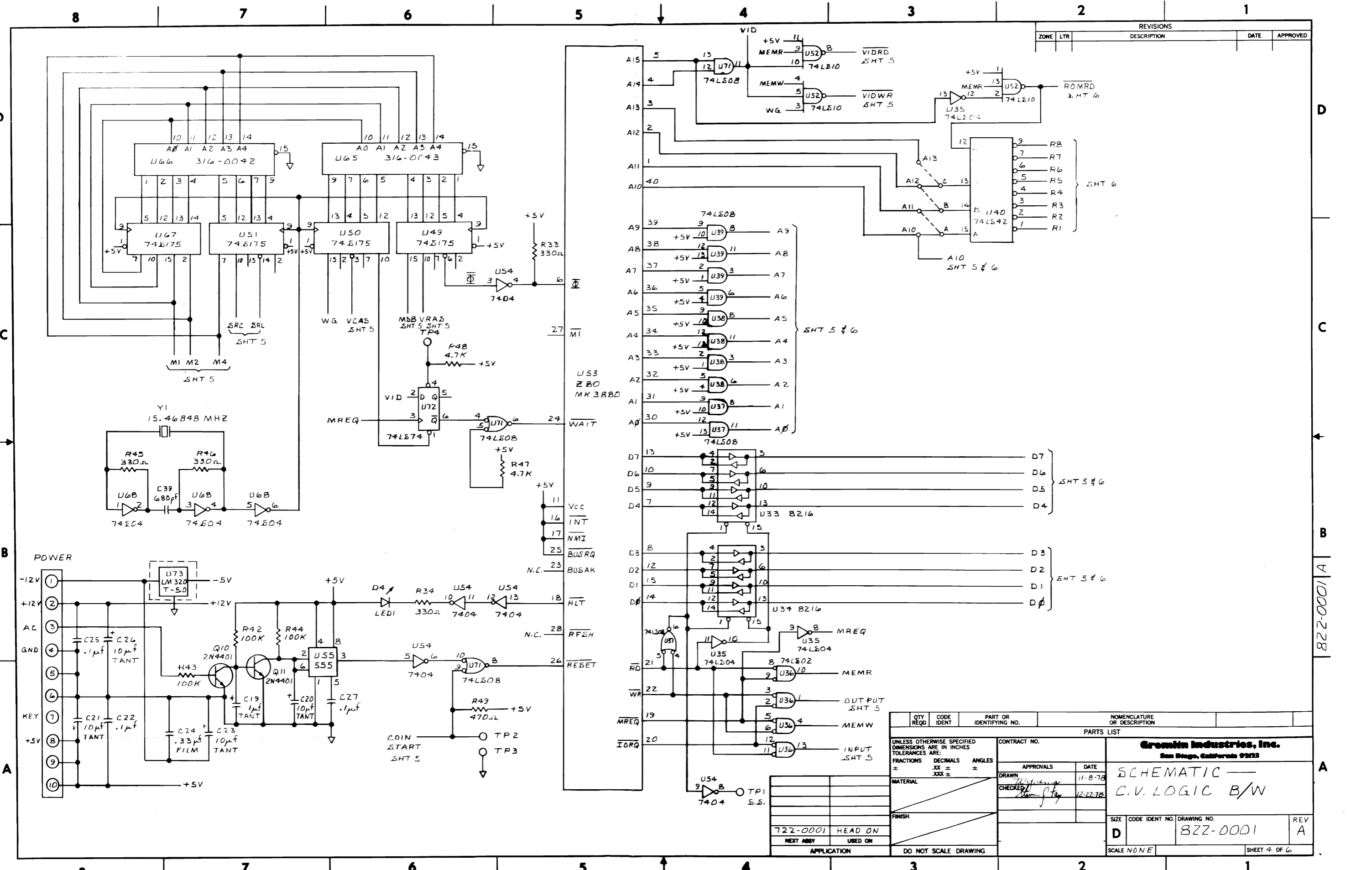

REVISIONS			
ZONE	LTR	DESCRIPTION	DATE

QTY REQD		CODE IDENT		PART OR IDENTIFYING NO.		NOMENCLATURE OR DESCRIPTION	

PARTS LIST	
UNLESS OTHERWISE SPECIFIED DIMENSIONS ARE IN INCHES TOLERANCES ARE:	CONTRACT NO.
FRACTIONS ± .XX ±	APPROVALS
DECIMALS ± .XXX ±	DATE
ANGLES ±	

Growth Industries, Inc.	
San Diego, California 92123	
SCHEMATIC —	
C.V. LOGIC B/W	

SIZE	CODE IDENT NO.	DRAWING NO.	REV
D		822-0001	A

SCALE	SHEET	TOTAL SHEETS
NONE	4	6

822-0001-A

A

REVISIONS				
ZONE	LTR	DESCRIPTION	DATE	APPROVED

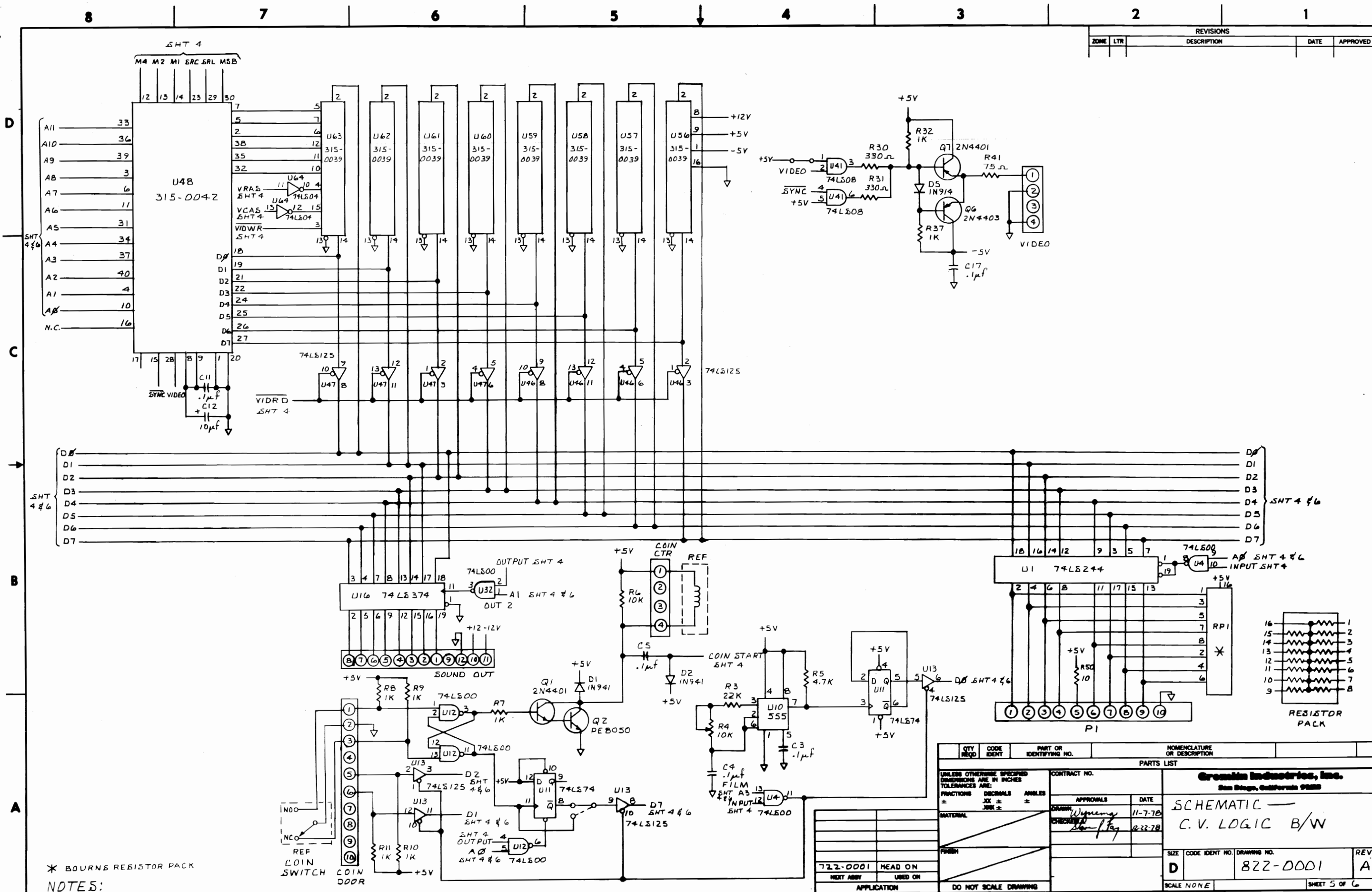

QTY REQD	CODE IDENT	PART OR IDENTIFYING NO.	NOMENCLATURE OR DESCRIPTION

PARTS LIST		CONTRACT NO.	
UNLESS OTHERWISE SPECIFIED DIMENSIONS ARE IN INCHES TOLERANCES ARE:	FRACTIONS	DECIMALS	ANGLES
±	JXX ±	±	±
MATERIAL			
FINISH			

APPROVALS	DATE

  

SIZE	CODE IDENT NO.	DRAWING NO.	REV
D	822-0001		A

\* BOURNS RESISTOR PACK  
 NOTES:

822-0001/A

REVISIONS				
ZONE	LTR	DESCRIPTION	DATE	APPROVED

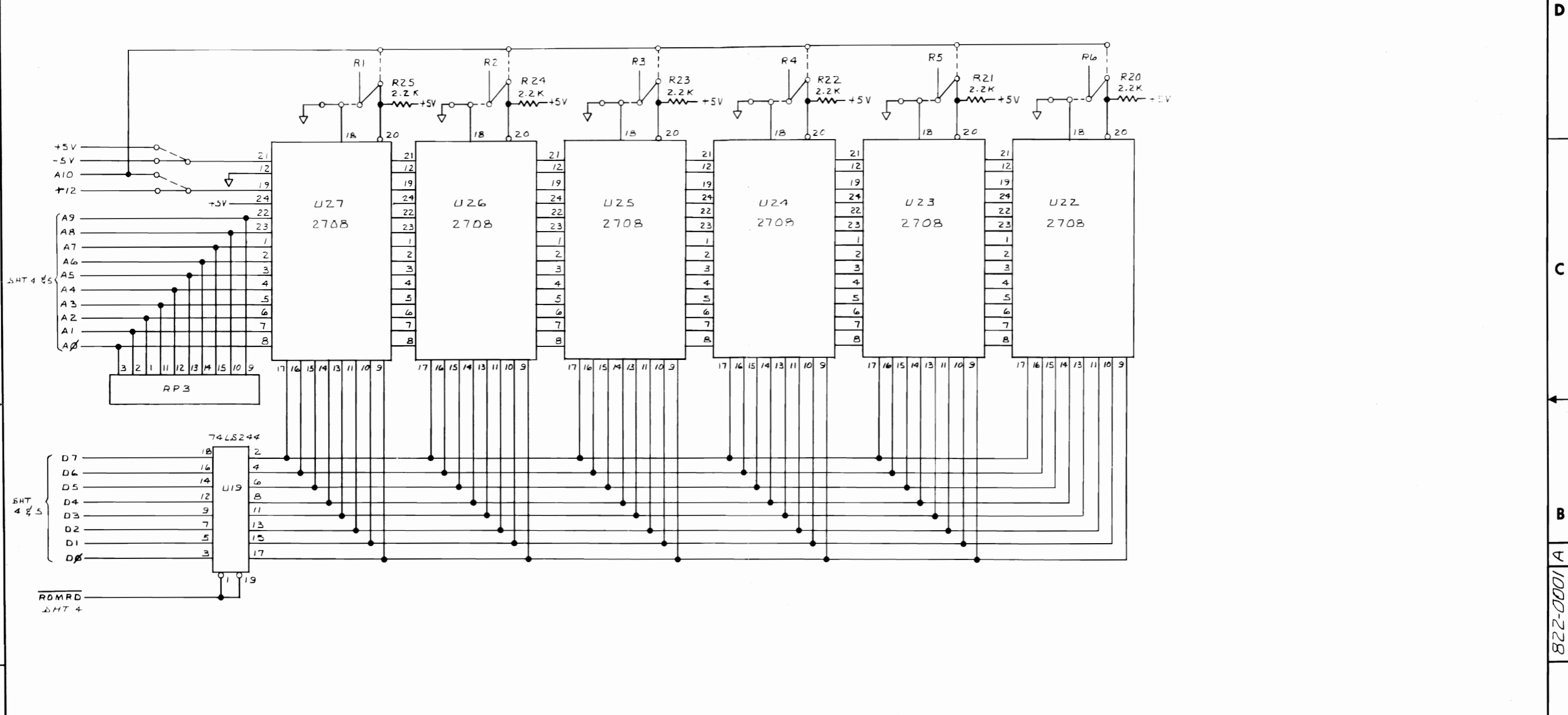

QTY REQD	CODE IDENT	PART OR IDENTIFYING NO.	NOMENCLATURE OR DESCRIPTION
PARTS LIST			
UNLESS OTHERWISE SPECIFIED DIMENSIONS ARE IN INCHES TOLERANCES ARE:		CONTRACT NO.	
FRACTIONS ±	DECIMALS .XX ±	ANGLES ±	
MATERIAL		APPROVALS	DATE
FINISH			
722-0001 HEAD ON			
NEXT ASSY USED ON			
APPLICATION			
DO NOT SCALE DRAWING			
Grenlin Industries, Inc. San Diego, California 92123			
DRAWN: <i>Wynema</i> 10-30-78			
CHECKED: <i>Sto-fay</i> 12-22-78			
SIZE	CODE IDENT NO.	DRAWING NO.	REV
D		822-0001	A
SCALE NONE			SHEET 6 OF 6

822-0001 A

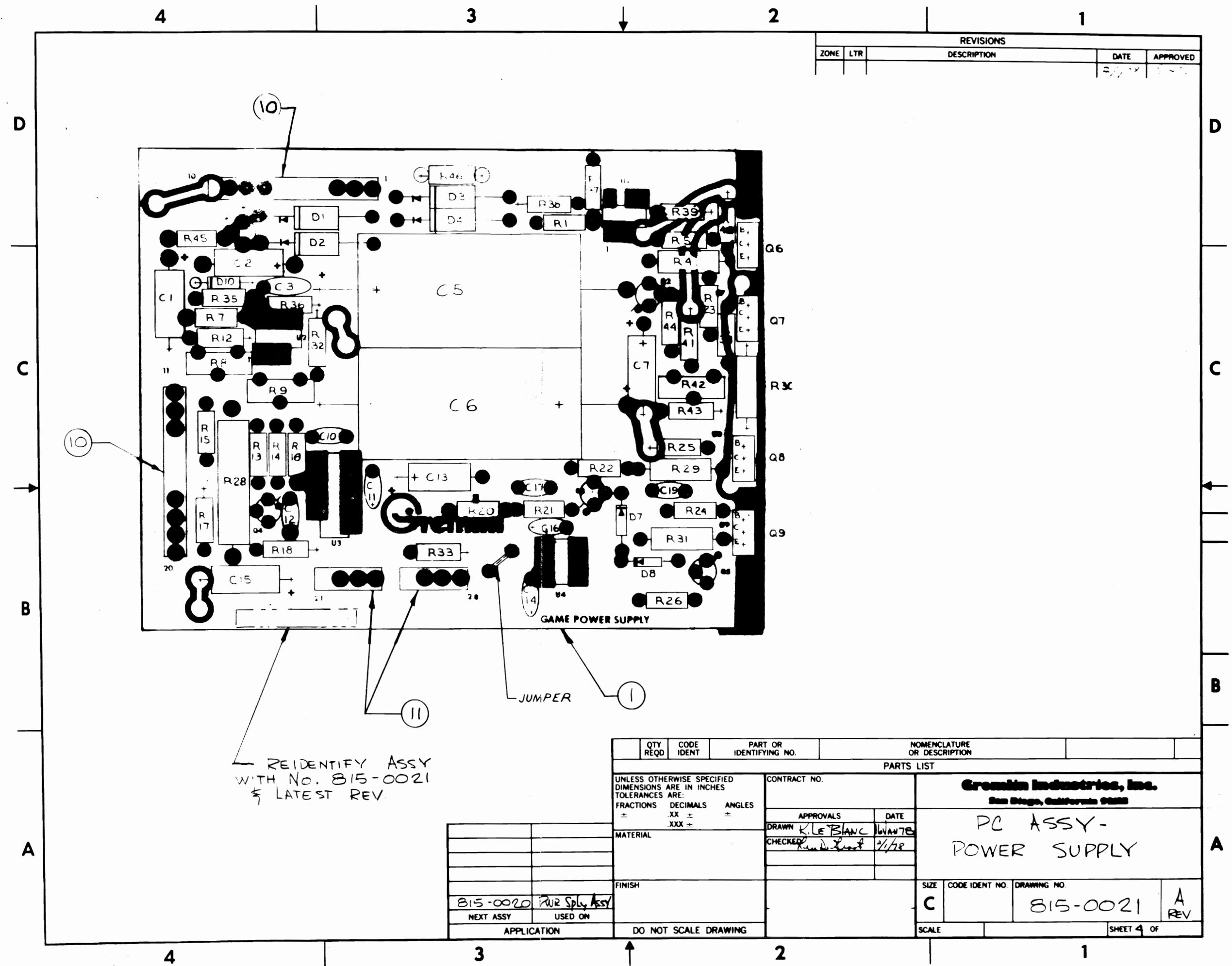

REVISIONS			
ZONE	LTR	DESCRIPTION	DATE

REIDENTIFY ASSY WITH No. 815-0021 & LATEST REV.

QTY REQD	CODE IDENT	PART OR IDENTIFYING NO.	NOMENCLATURE OR DESCRIPTION
PARTS LIST			
UNLESS OTHERWISE SPECIFIED DIMENSIONS ARE IN INCHES TOLERANCES ARE:		CONTRACT NO.	
FRACTIONS	DECIMALS	ANGLES	
±	XX ±	±	
MATERIAL		APPROVALS	DATE
		DRAWN K. LE BLANC	WANTER
		CHECKED [Signature]	1/18
FINISH		Groskin Industries, Inc. San Diego, California 92108	
		PC ASSY - POWER SUPPLY	
B15-0020	Power Sply Assy	SIZE C	CODE IDENT NO. 815-0021
NEXT ASSY	USED ON	DRAWING NO.	815-0021
APPLICATION		DO NOT SCALE DRAWING	
		SCALE	
		SHEET 4 OF	

D  
C  
B  
A

D  
C  
B  
A

4 3 2 1

4 3 2 1

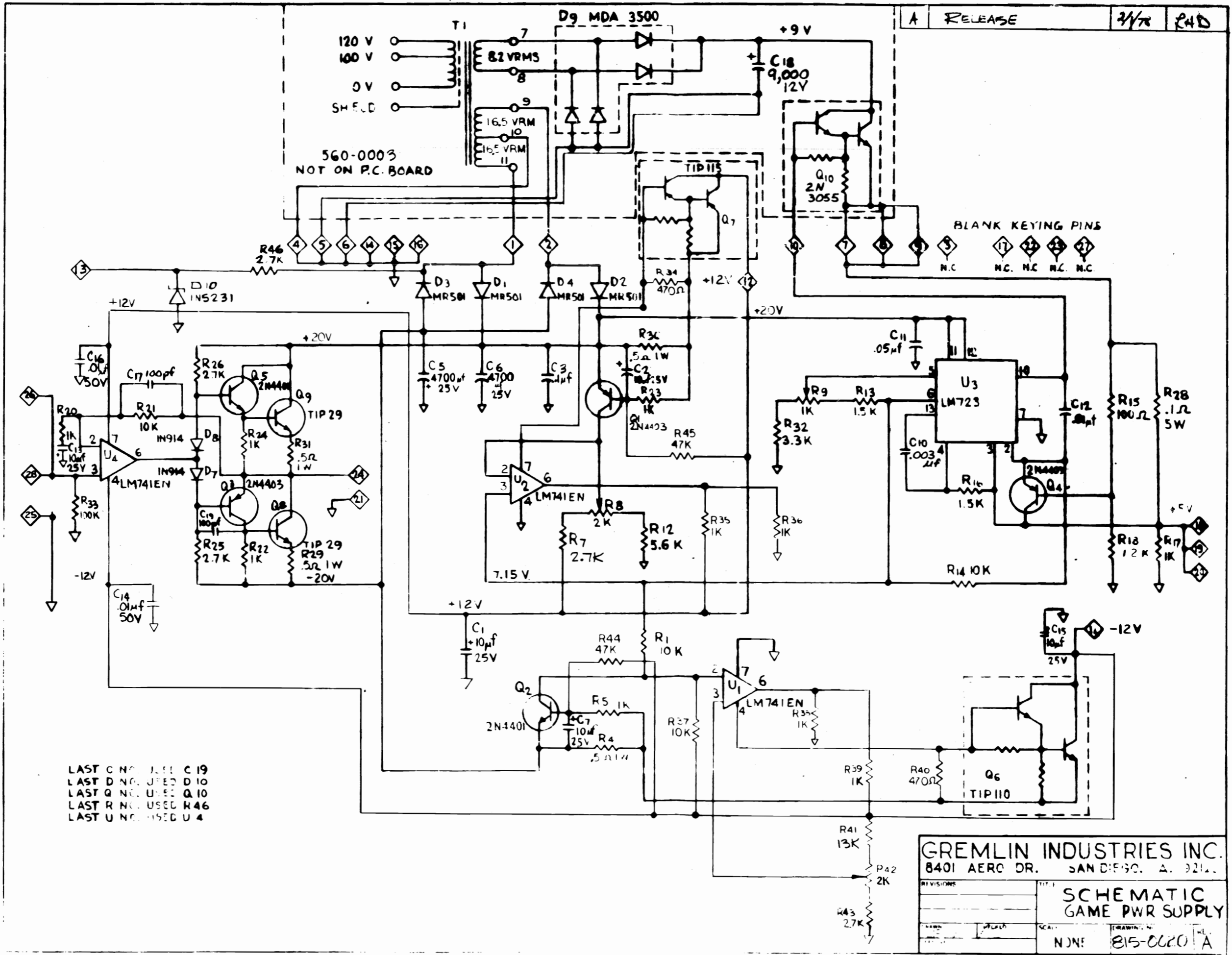

LAST C NO. USED C 19  
 LAST D NO. USED D 10  
 LAST Q NO. USED Q 10  
 LAST R NO. USED R 46  
 LAST U NO. USED U 4

**GREMLIN INDUSTRIES INC.**  
 8401 AERO DR. SANDERS, A. 2212.

REVISIONS	TITLE
	SCHEMATIC
	GAME PWR SUPPLY
	SCALE
	DRAWING NO.
	815-0020
	A

SHEET 4