

**IRONMAN**

Ivan Stewart's<sup>®</sup>

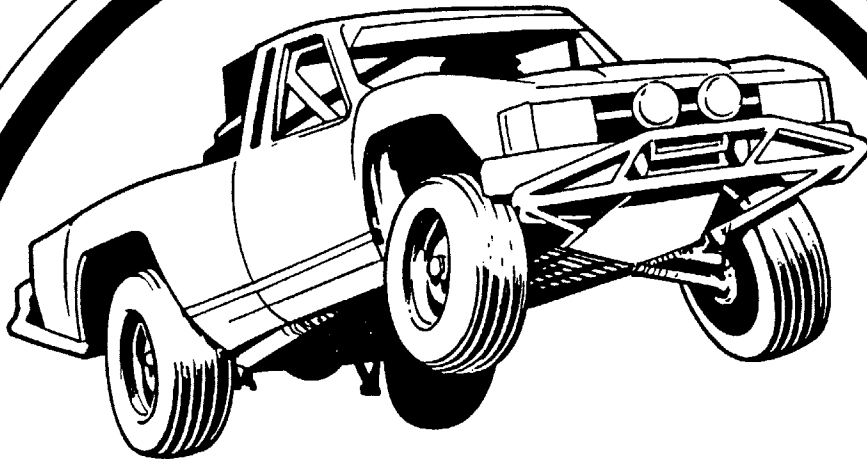

**OFF ROAD**™

*Leland*  
CORPORATION

**OWNERS MANUAL**

**"Ivan IRONMAN Stewart's  
SUPER OFF-ROAD™  
TABLE OF CONTENTS**

<b>SECTION</b>	<b>PAGE</b>
A. GENERAL GAME INFORMATION	
1. Game Concept	1
2. Assembly Instructions	2
3. Warranty Information	4
4. Maintenance and Upkeep Procedures	5
C. THE TROUBLESHOOTISTS SECTION	
1. A Note About Power	6
2. Our Service Department	6
3. Troubleshooting Flow Chart	7
4. General Shooting	8
5. Monitor Shooting	8
6. Buffers	8
7. About Mechanical Coin Counters	9
D. ILLUSTRATED PARTS LIST	
1. Cabinet	10
2. Controls ( buttons, foot pedals, steering wheels, etc.)	11
E. WIRING DIAGRAMS	
1. Main Board	12
2. Multi-Function Board	14
3. Cabinet	16
F. BOOKKEEPING AND DIAGNOSTICS SECTION	
1. Main Menu - Bookkeeping - Diagnostics Menu	17
2. Video Alignment Screens	21
3. Game Set-Up - Game Statistics	23
E. SCHEMATICS & BOARD LAYOUTS	
1. Multi-Function Board Layout (top board)	27
3. Multi-Function Board Schematics	28
4. Main Board Layout (bottom board)	38
5. Main Board Schematics	39
6. 25" Wells Gardner Monitor	58

**'Ivan IRONMAN Stewart's  
SUPER OFF ROAD™  
GAME CONCEPT**

In his never ending quest for adventure and excitement, man invented off-road racing. These races were then brought before the masses by converting huge sports stadiums into dirt and mud obstacle courses in which off-road "Ironmen" battled for top honors.

Now **THE LELAND CORPORATION** brings this fast moving, hard driving sport to the video game arena.

**'Ivan IRONMAN Stewart's SUPER OFF-ROAD™** is stadium off-road racing at it's best. One to three players are asked to test their dirt track skills against the best dirt truck driver in the world.

Contestants compete on 8 different tracks with a total of 16 configurations and these courses are packed with enough jumps, bumps, hills, and holes to challenge even the most skillful driver.

Winning drivers earn "cash" prizes, and use this "cash" to "buff out" their machines. At the end of each race, players take their trucks to the "Speed Shop" to buy better shocks, tires, engines, and higher top speed. They can also buy nitro packs to help them blast over the jumps and through the mud.

The **"Convert-a-Credit™** feature allows drivers to add to their winnings by using credits as "cash". Each additional quarter, when converted, becomes \$200,000.00 in game "cash" and this additional "cash" may be used for purchases in the "Speed Shop".

Team Leland's **'Ivan IRONMAN Stewart's SUPER OFF-ROAD™** has the depth and variety to be an income 'winner' for years to come.

"Ivan IRONMAN Stewart's  
*SUPER OFF-ROAD*"™  
CABINET ASSEMBLY ILLUSTRATION

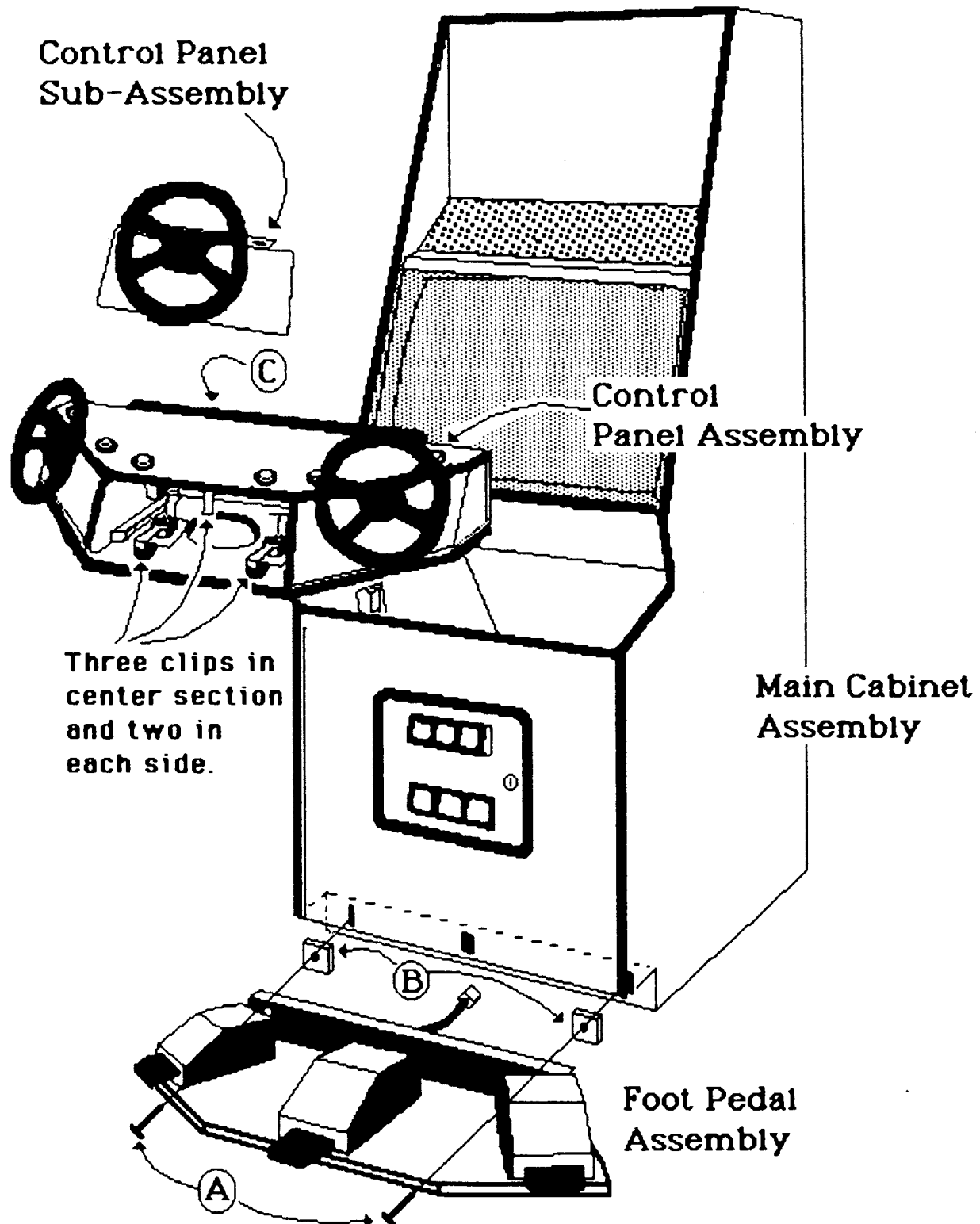

## ASSEMBLY INSTRUCTIONS

1. Remove all parts from shipping containers and check them for damage. Notify your distributor (and the shipper) **immediately** if you find any broken parts.
2. Detach and remove the pedal assembly from the inside of the main cabinet. Remove the two bolts **(A)** and blocks **(B)** from the bottom front of the main cabinet.
3. At this point, it is a good idea to lift the monitor plex and clean or dust from the monitor any debris which may have settled in shipment.
4. Remove the center (yellow) steering section from the control panel assembly by reaching through the hole in the bottom of the assembly and unfastening the three clips inside. Attach the monitor plex retainer **(C)** to the control panel assembly. (The wing nut should be loose until the control panel assembly has been attached to the game cabinet.)
5. Position the control panel with the harness connectors hanging into the main cabinet and secure the panel to the main cabinet by reaching through the front door and attaching the four clips provided.
6. Connect the control panel harness to the main harness, tighten the wing nut on the monitor plex retainer and reinstall the center steering section.
7. Feed the pedal harness through the center hole in the lower part of the cabinet and attach the pedal assembly using the bolts **(A)** and blocks **(B)** removed in step 2. **REMOVE THE PEDAL ASSY. WHEN TRANSPORTING THE GAME.**
8. Check through the cabinet for loose wires. Plug the game in and power-up. Check for smoke.
9. Go through all diagnostics and game set-up procedures and **PLAY THE GAME**. If it works - don't fix it, just get it out there and

***Do it in the dirt!***

*Please call our Customer Service Department with any questions or comments.*

# THE TROUBLESHOOTIST'S SECTION

## A NOTE ABOUT POWER

### **DC POWER**

The computer board in this machine operates most efficiently when the power supply is providing a steady + 5.20VDC ( +0.1VDC). When checking DC power always put your leads across the power inputs on the main board and be sure that the +5 volt supply is between +5.20VDC and +5.24VDC. Also be sure that there is less than .005 volts AC riding on the +5 volt line. If you do find AC on the DC line, suspect the filter capacitor or the rectifier on the power supply. Low voltage and AC on the DC lines are the main causes of the following problems:

- \* "Garbage" on the screen.
- \* Computer "Freeze".
- \* Coin or Coin Meter malfunction.
- \* A variety of seemingly unrelated problems.

### **AC POWER**

Connect this game only to a grounded three-wire outlet which provides between 108 and 132 volts AC. If you have only a two-wire outlet we recommend that you hire a licensed electrician to install a grounded outlet. The possibility exists that players may receive an electrical shock if this system is not properly grounded.

## **OUR SERVICE DEPARTMENT**

For parts, service, and technical information first contact your authorized Leland Corporation distributor. For additional technical aid feel free to contact the Leland Corp. Customer Service Department at **(619)562-7000** Monday through Friday from **8:00 AM to 5:00 PM Pacific Standard Time**.

To provide you with the quickest possible response to your questions, please have the following information ready when you call:

- 1. Your game name and serial number.**
- 2. Any reference materials and a list of observations.**

## TROUBLESHOOTING FLOW CHART

**DON'T TOUCH THAT SWITCH !!!**

Before you reach for the power switch take a good look at the game. Open it up and check for loose wires, bad connections, or burned spots. Look for spilled drinks and signs of vandalism. Those quick checks will save you a lot of time.

After you've eliminated the obvious, start digging.

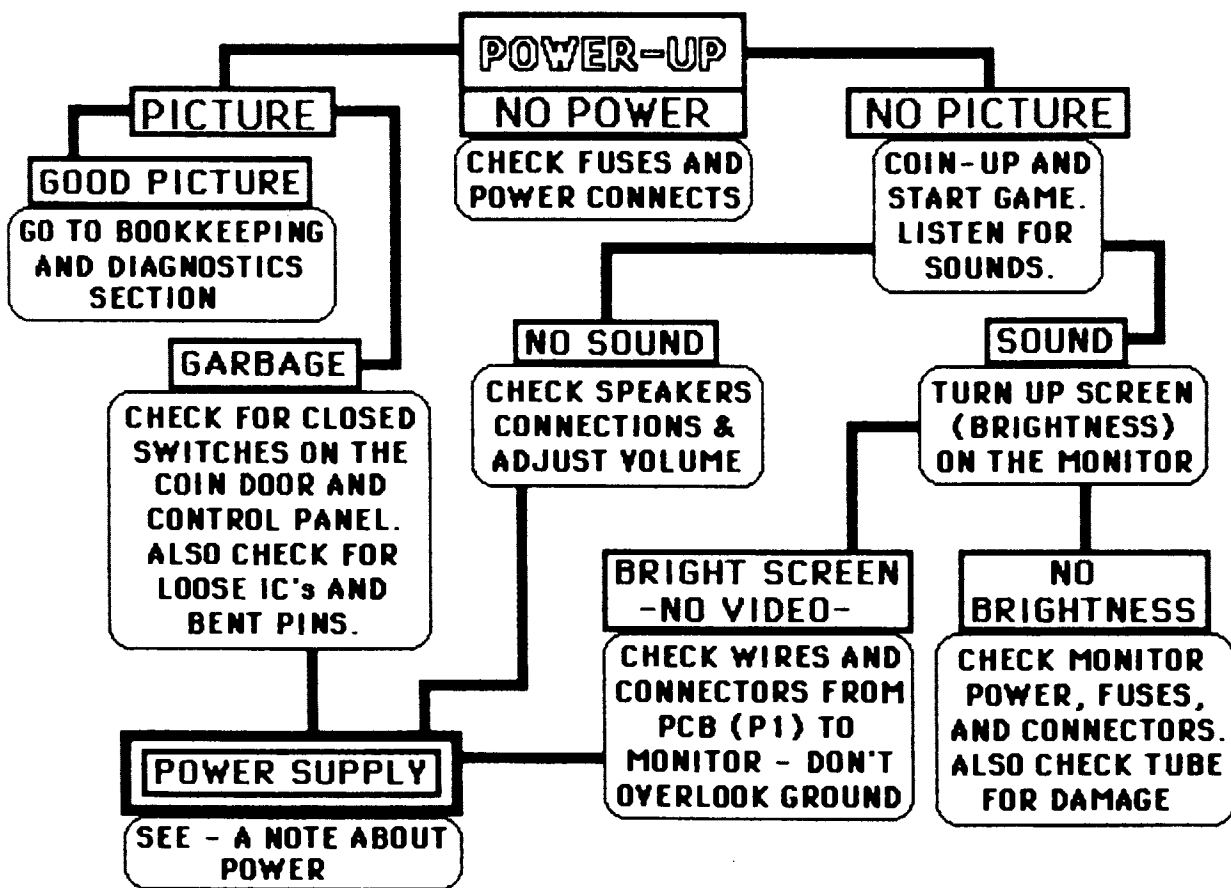

Never take anything for granted. This is easy to do if you are in a hurry --- You'll kick yourself every time for missing a broken wire or loose connector after spending hours looking in the wrong place - I have.

## **GENERAL SHOOTING**

### **GARBAGE**

Check: Power supply voltages.  
Closed switches on the control panel or coin door.  
Loose connections, loose IC's, or bent pins on the board.

### **NO SOUND**

Check: Loose connections.  
Low +12VDC supply.  
Bad speaker or volume pot.

### **NO CONTROL OR FUNCTION SWITCHES (Includes coin switches)**

Check: All Connections. (Especially ground)  
Wire continuity between board and switch.  
Closed or broken switches.  
Input buffers. (See BUFFERS.)

## **MONITOR SHOOTING**

### **NO PICTURE**

Check: Power connection.  
Monitor fuses.  
Video connections. (Check continuity.)

### **SYNC PROBLEMS**

Check: Sync and ground connections. (See WIRING DIAGRAM)  
Sync polarity.  
Video output buffer.

## **BUFFERS**

An input or output (I/O) buffer is the component that connects the actual game computer to the outside world and, as such, is the part most likely to fail. Check the following list when attempting to isolate possible problems. First and second choices are given. (M=Main Board, I/O= Multi-Function Board.)

***NOTE: ANY UNAUTHORIZED BOARD REPAIR OR ATTEMPTED REPAIR  
WILL VOID YOUR WARRANTY.***



<b><u>PROBLEM AREA</u></b>	<b><u>COMPONENT</u></b>	<b><u>PCB LOCATION</u></b>
VIDEO (Colors or Sync)	1 <sup>st</sup> 7405 or 74S05 2 <sup>nd</sup> 74LS374	M-U24 M-U37
PLAYER CONTROLS and/or COIN CONTROLS	1 <sup>st</sup> 150 ohm resistor pack. 2 <sup>nd</sup> 74LS257	See Wiring Diagram & Schematics for specific switch.
AUDIO (Bad channel)	1 <sup>st</sup> 7524  2 <sup>nd</sup> 7533	I/O-U35(ch5) through U40 (ch0) I/O-U31

## ABOUT MECHANICAL COIN COUNTERS

We have not installed mechanical coin counters on this game for two reasons:

1. The bookkeeping program is extremely accurate and includes not only number of coins dropped and dollars earned but also the number of tests and coins in a given period. (See BOOKKEEPING in the DIAGNOSTICS section.)

2. These mechanical coin counters produce an inductive "kick" that ~~will~~ damage components on the circuit board.

Checkerboard video is the most common problem. If this is, in fact, your problem - take a look at the "NMI not" signal on the master Z80 (pin 17). If a low output is observed, try replacing U114 (74LS08) and/or U119 (74LS157).

*NOTE: If you must install a mechanical coin counter, please use the following diagram. (Diodes may be 1N4001 to 1N4004.)*

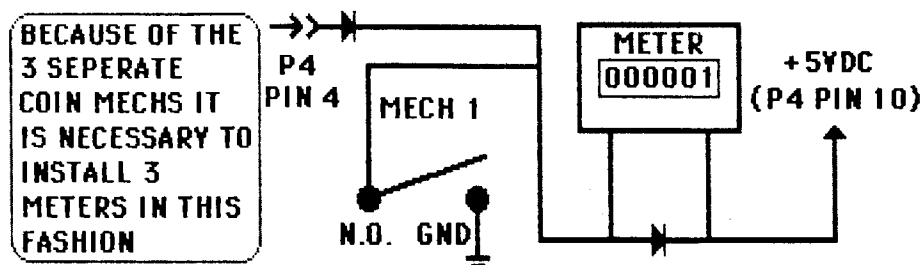

**"Ivan IRONMAN Stewart's  
SUPER OFF-ROAD"™  
ILLUSTRATED PARTS LIST**

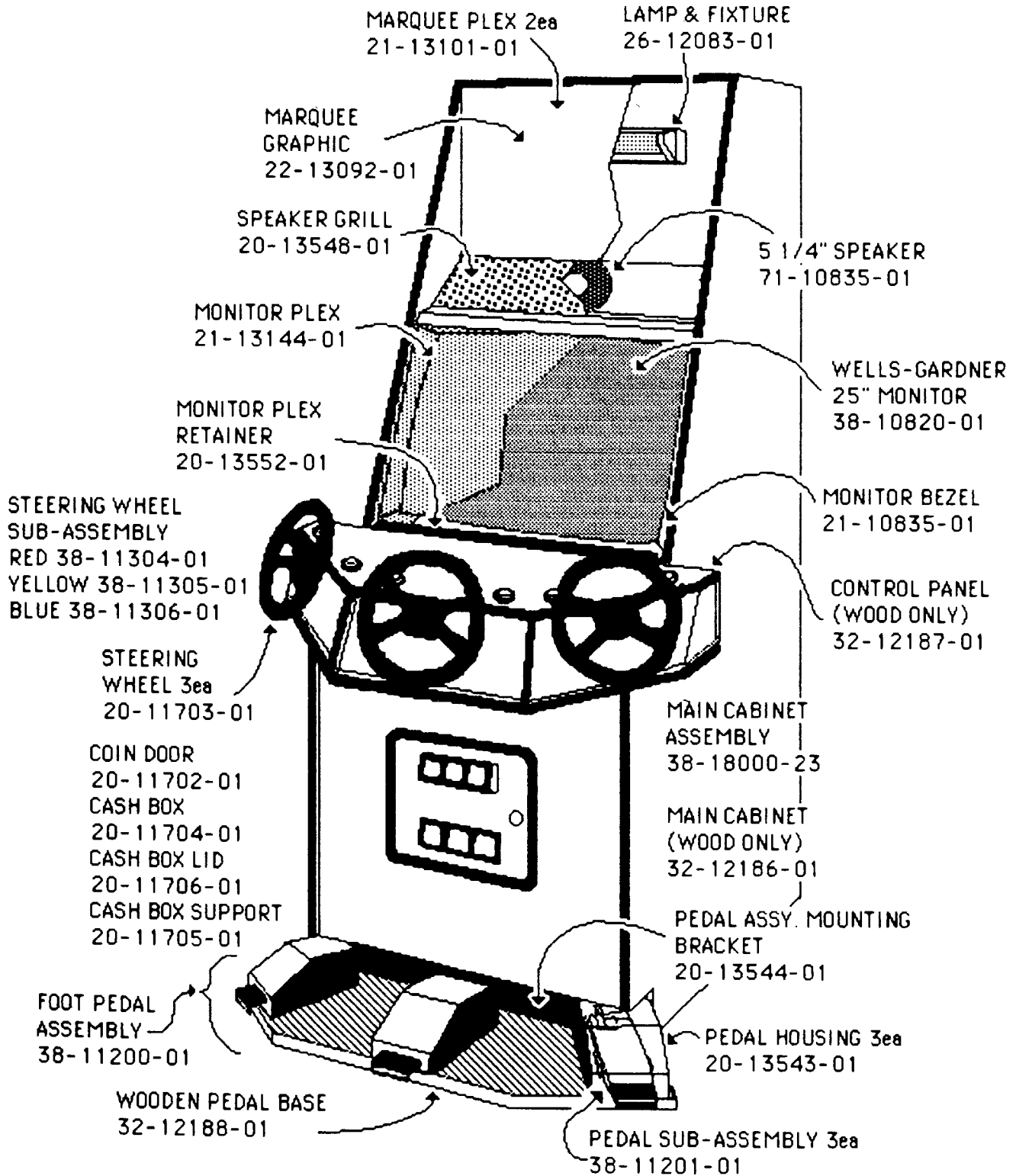

# OTHER PARTS

## CONTROL PANEL

PANEL TOP OVERLAY 22-14924-01

### SUB-PANEL OVERLAYS

RED - 22-14921-01

YELLOW - 22-14922-01

BLUE - 22-14923-01

BUTTON - MICRO 2ea

RED - 37-11194-01

YELLOW - 37-11196-01

BLUE - 37-11195-01

LATCH 11ea - 20-10867-01

(7 inner panel and 4 cabinet)

## STEERING ASSEMBLY

### METAL PANELS

RED 20-13549-01

YELLOW 20-13550-01

BLUE 20-11551-01

### ENCODER WHEEL

25-11007-01

LARGE GEAR 25-11008-01

SMALL GEAR 25-11009-01

## MISCELLANEOUS

ON/OFF SWITCH - 37-10894-01

VOLUME POT - 51-12501-01

LEG LEVELER - 20-13530-01

## PEDAL ASSEMBLY

SHOULDER BOLT

4"x1/2" STAINLESS

25-18251-01

POTENTIOMETER

51-12502-01

ARMATURE

20-13540-01

SPRING - 20-15061-01

## ELECTRONICS

PCB ASSEMBLY COMPLETE

38-11695-22

MAIN (BOTTOM) PCB

81-12170-14

MULTI FUNCTION #2 (TOP) PCB

81-18002-22

STEERING OPTO COUPLER PCB

80-20000-01

## POWER SUPPLY

ISOLATION TRANSFORMER

43-11704-01

SWITCHING POWER SUPPLY

82-12150-01

LINE FILTER - 63-12131-01

POWER CORD - 87-12143-01

**TO  
MONITOR**

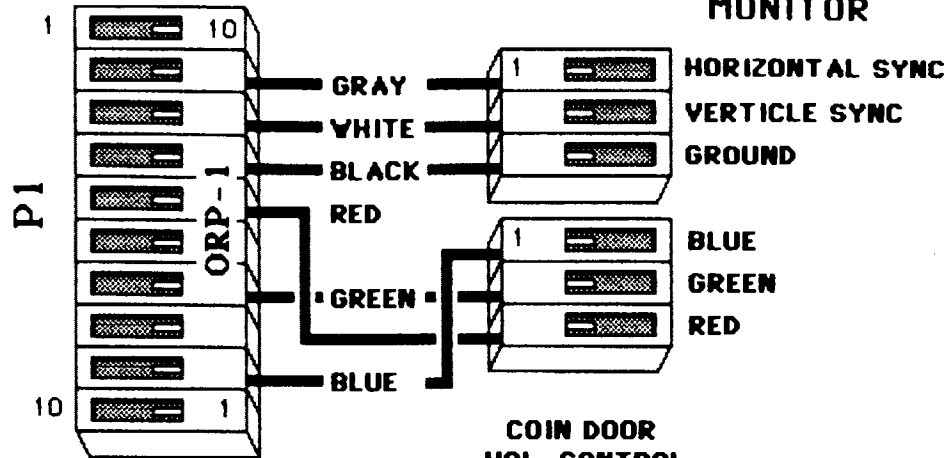

**MAIN WIRING  
DIAGRAM  
(MAIN BOARD)**

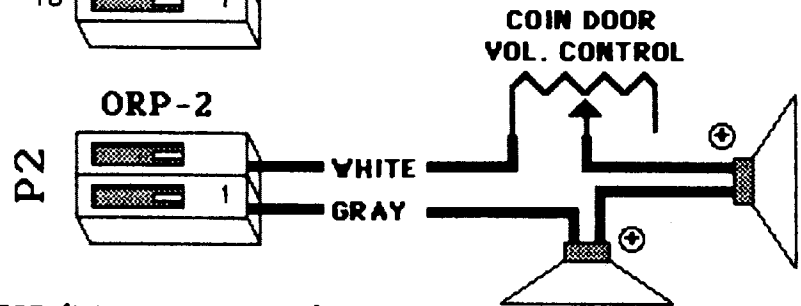

**TOP (MULTI-FUNCTION) PCB**

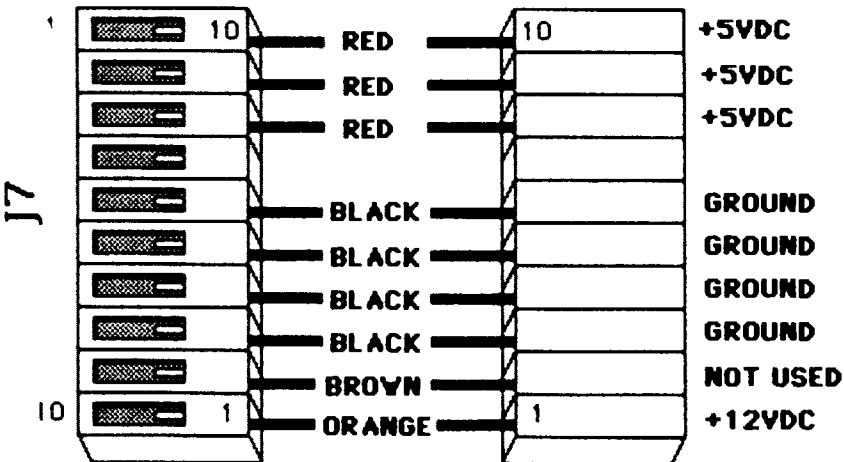

*NOTE: SYSTEM PIN-OUT  
OPPOSITE OF PIN-OUT  
MOLDED IN HARNESS  
CONNECTORS.*

**P3**

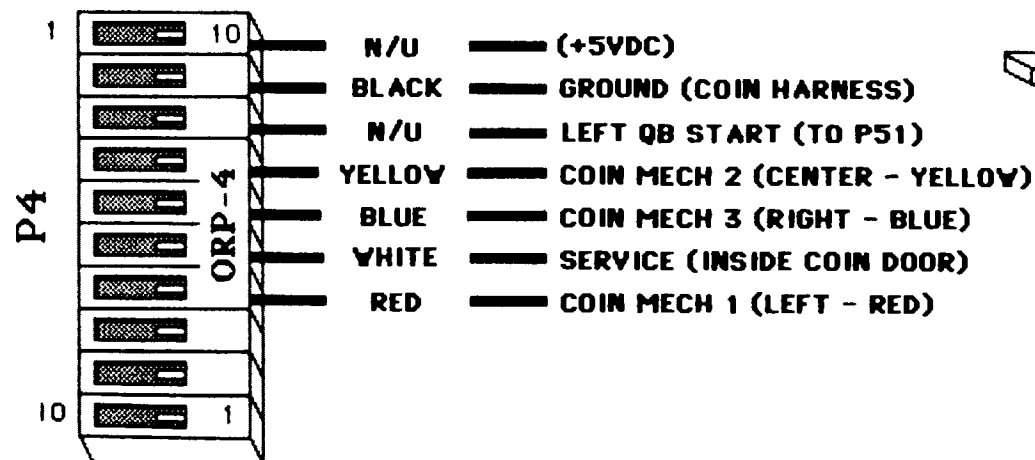
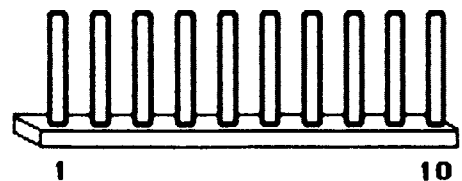
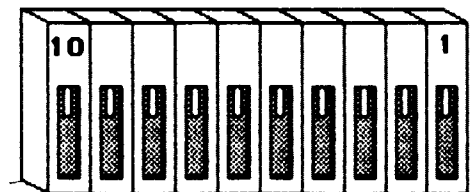

CP-5 SP-5

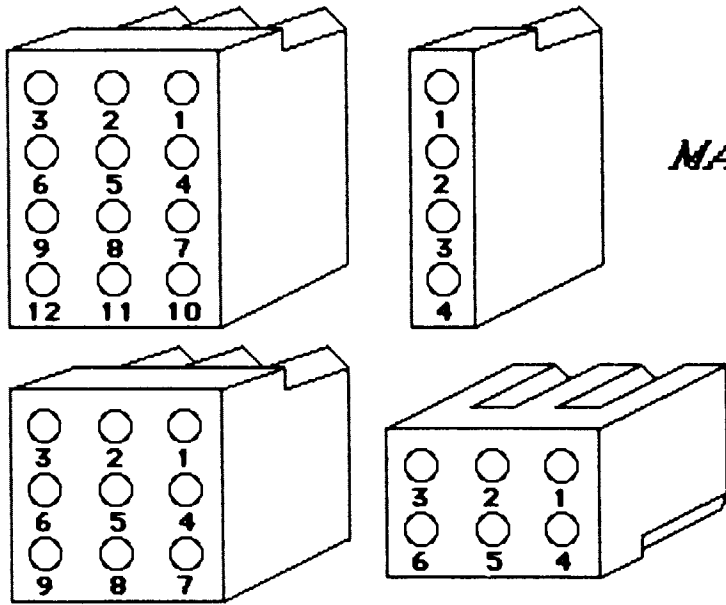
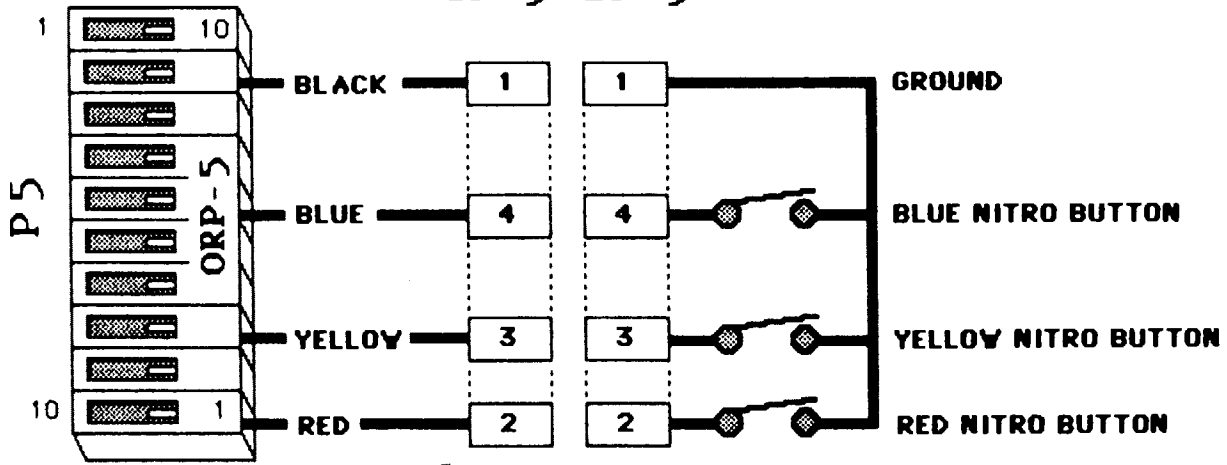

*MALE MOLEX CONNECTORS  
TYPICAL PIN-OUT*

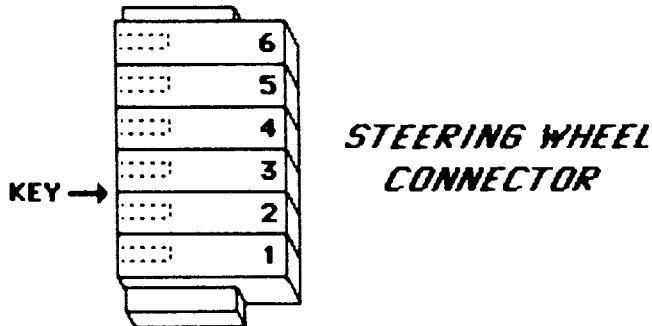

*STEERING WHEEL  
CONNECTOR*

*SEE MAIN BOARD LAYOUT  
FOR BOARD CONNECTOR  
LOCATIONS.*

# MAIN WIRING DIAGRAM (MULTI-FUNCTION BOARD)

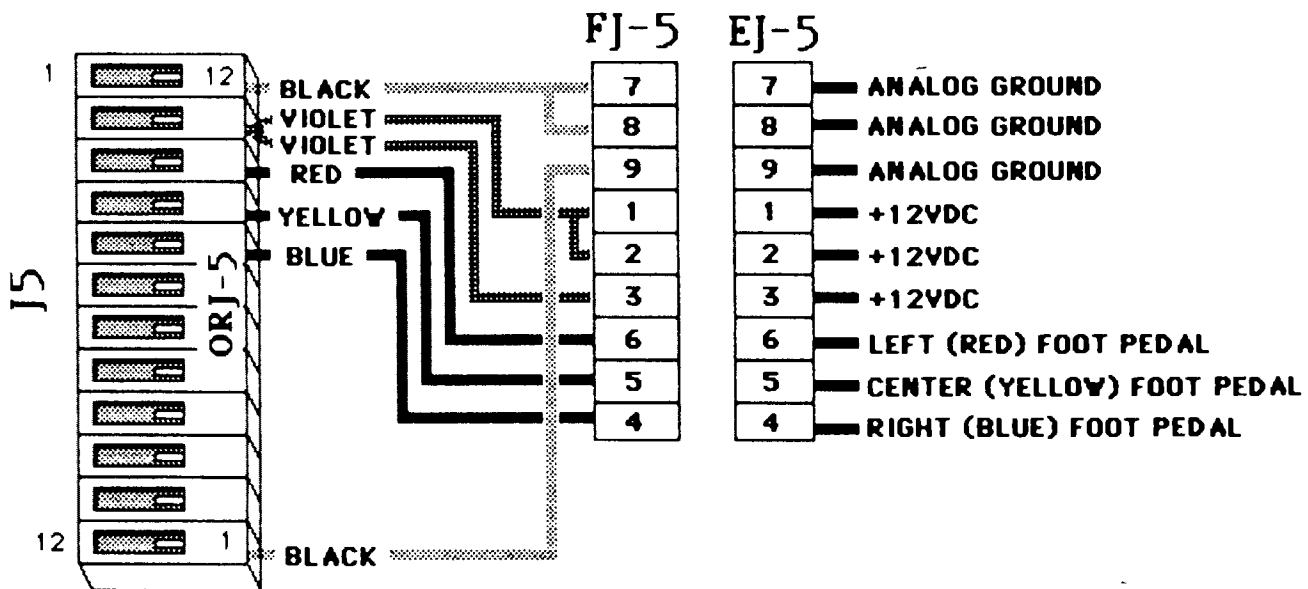
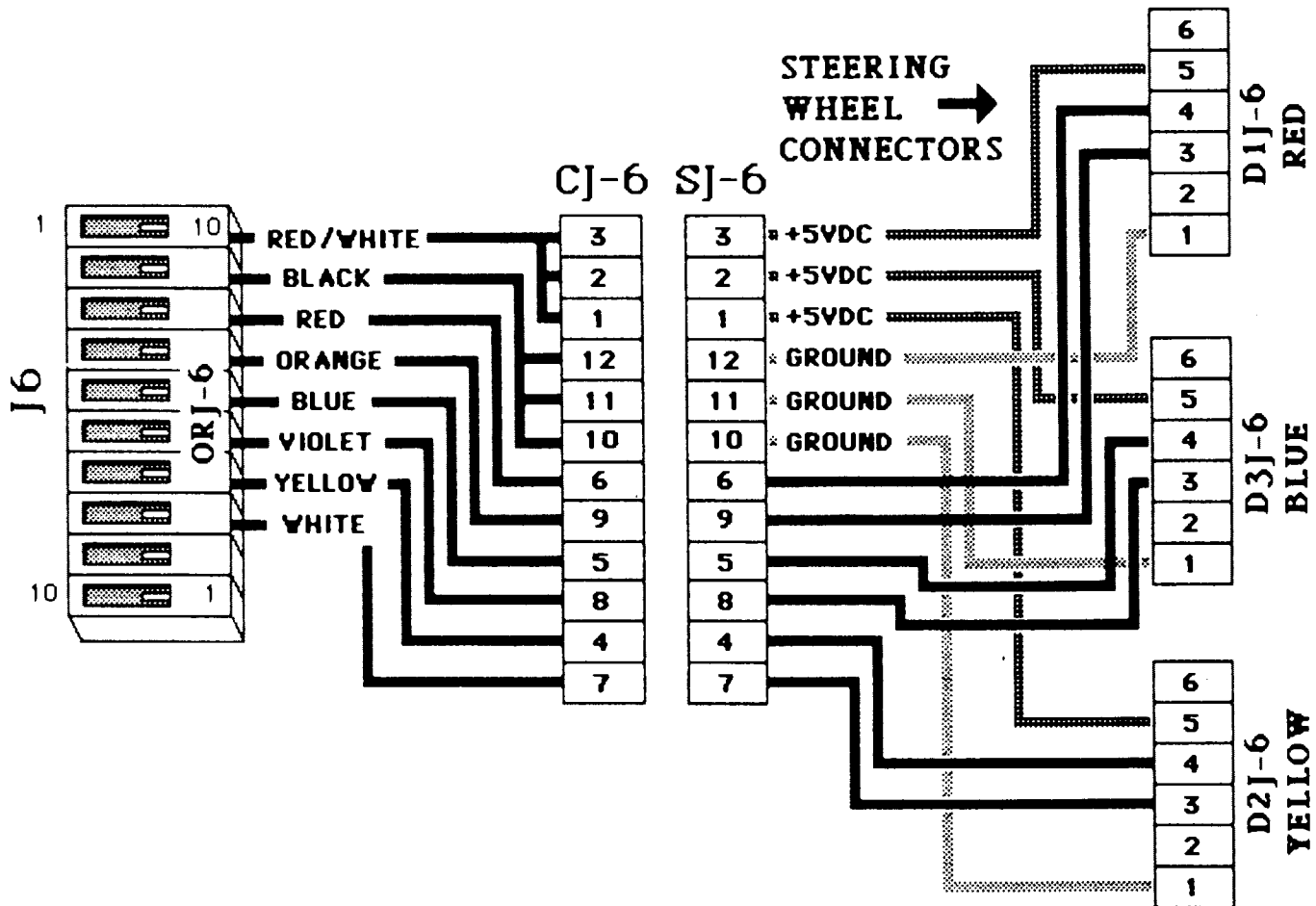

**FROM SWITCHING  
POWER SUPPLY**

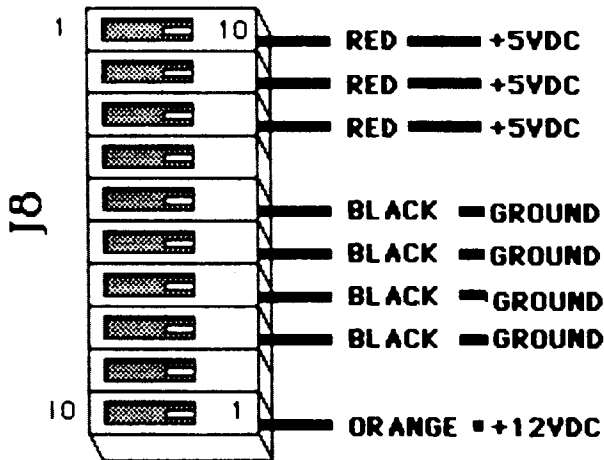

**SEE P7 ON MAIN BOARD  
WIRING DIAGRAM**

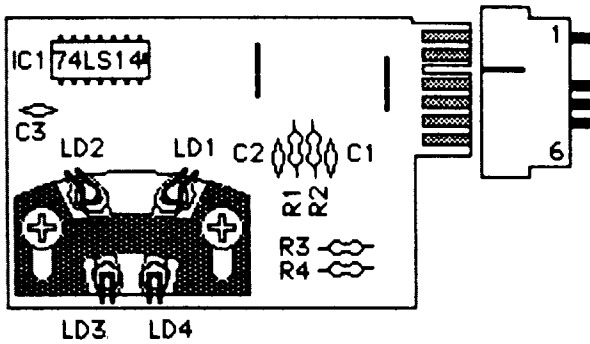
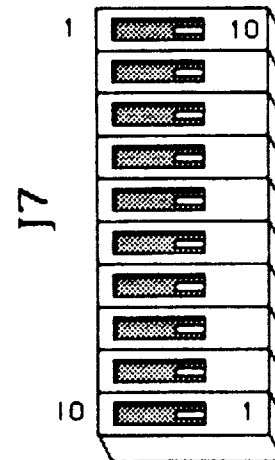

**STEERING OPTO-  
COUPLER PCB  
CONNECTION**

**FOOT PEDAL  
POTENTIOMETER  
HOOK-UP**

12VDC (VIOLET)  
CONTROL  
(CAR COLOR)  
GROUND (BLACK)

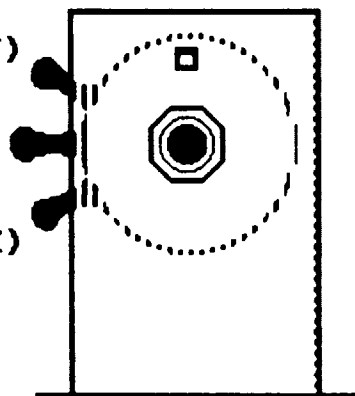

# CABINET WIRING DIAGRAM

**AC POWER**  
 108 - 132 VAC  
 2.5A MAX

**DC POWER**  
 +5VDC @ 11A  
 +12VDC @ 2A  
 -5VDC @ 1A

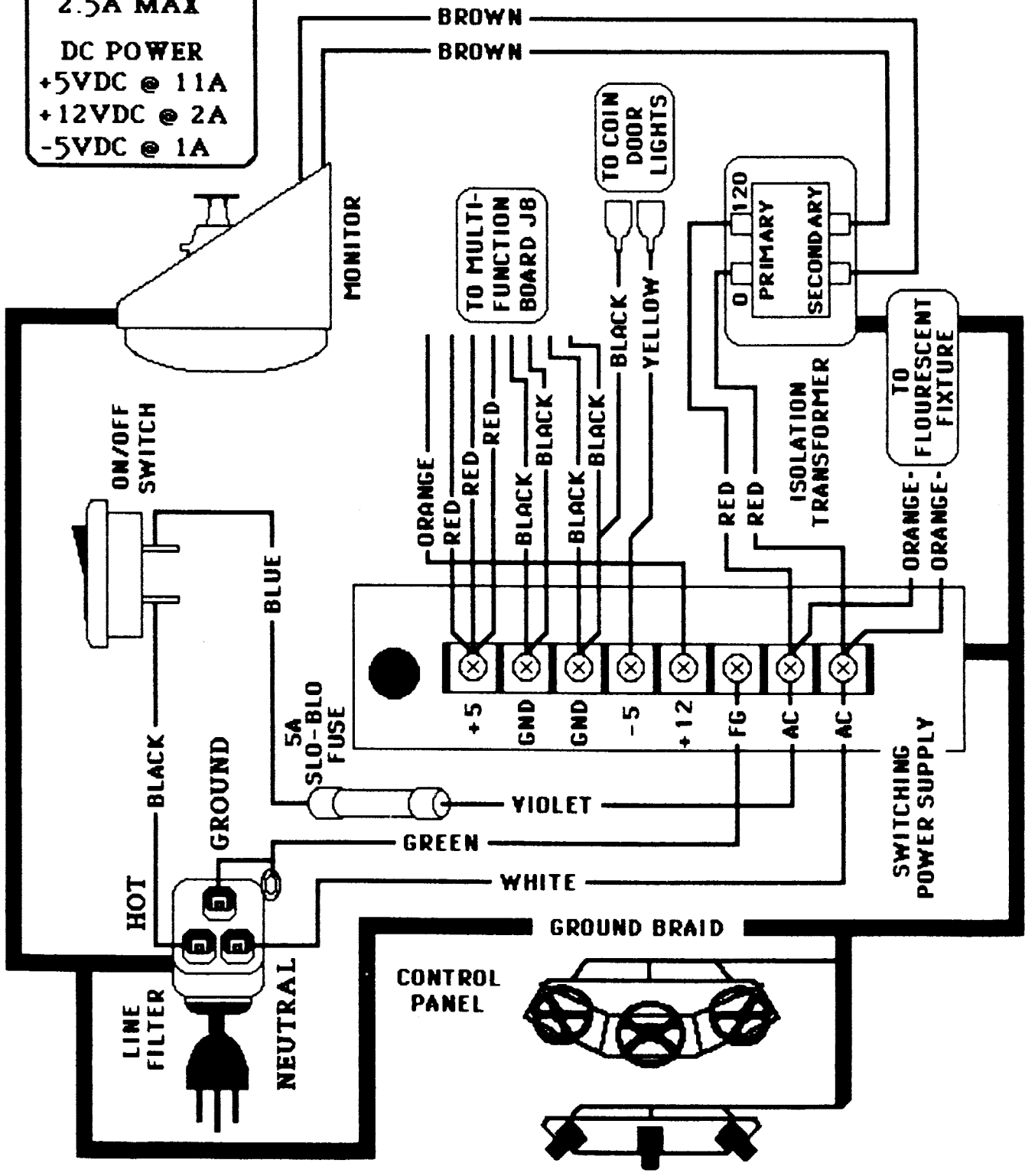



# BOOKKEEPING AND DIAGNOSTICS SECTION

To enter the Bookkeeping and Diagnostics Section:

- \* With the **Blue Nitro** button depressed, press the **Test** button located inside the front door on the left.

Upon entering the program, the **Main Menu** will appear (Figure 1). Follow the instructions on this menu to select and enter the desired function.

## **Bookkeeping** (Figure 2)

The Bookkeeping function is your game accountant. It records the life-time earnings of your game and allows you, through the use of resettable "Period" totals to keep track of weekly, monthly, or location earnings. This function also separates the readings by coin mech. If one of the coin mech readings is disproportionately low, you may suspect that your players are having trouble with either that mech or the controls of the car associated with that mech.

**NOTE:** The **"SET COINS/TOKENS PER DOLLAR"** category must be set to the location standard to maintain accurate accounting data.

(i.e. 6 COINS/TOKENS PER DOLLAR.)

**THIS FUNCTION DOES NOT AFFECT THE NUMBER OF COINS PER CREDIT - SEE THE "GAME SET-UP" SECTION FOR COINS PER CREDIT INFORMATION.**

## **Diagnostics** (Figure 3)

You will notice the Diagnostics Section has a sub-menu of its own. Invoking the Diagnostics function will open a complete and easy to use set of tests designed to take the grumbling and hair pulling out of adjusting, troubleshooting, and servicing your machine.

## **Buttons and Controls Test** (Figure 4)

This test provides a quick examination of the state of all buttons and controls as well as an easy range and direction setting format for the steering and pedal controls. As shown on the screen, the **minimum** setting for any foot pedal assembly is between **0 and 80**. Each pedal must also be able to achieve the **maximum** setting of **255** when fully depressed.

## **Processor Memory Test** (Figure 5)

The Erasable Programmable Read Only Memory (EPROM) and Random Access Memory (RAM) IC's are storage areas for the actual game guidelines and are accessed by the Microprocessor section.

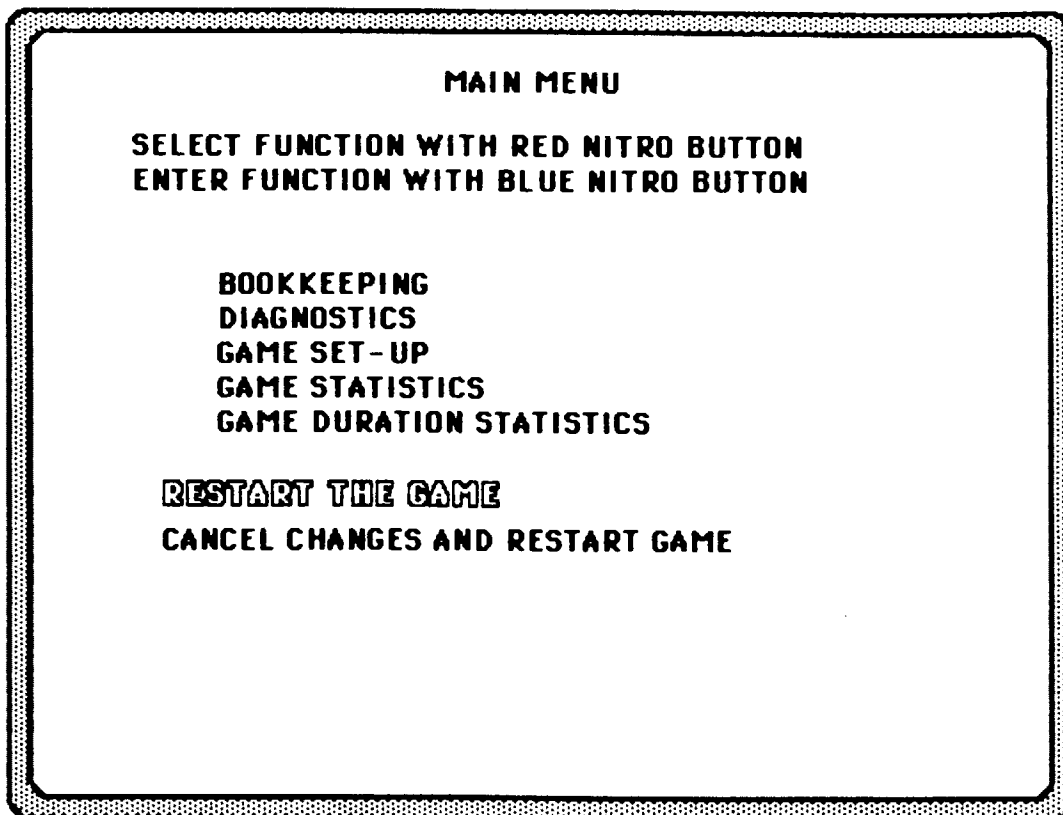

FIGURE 1

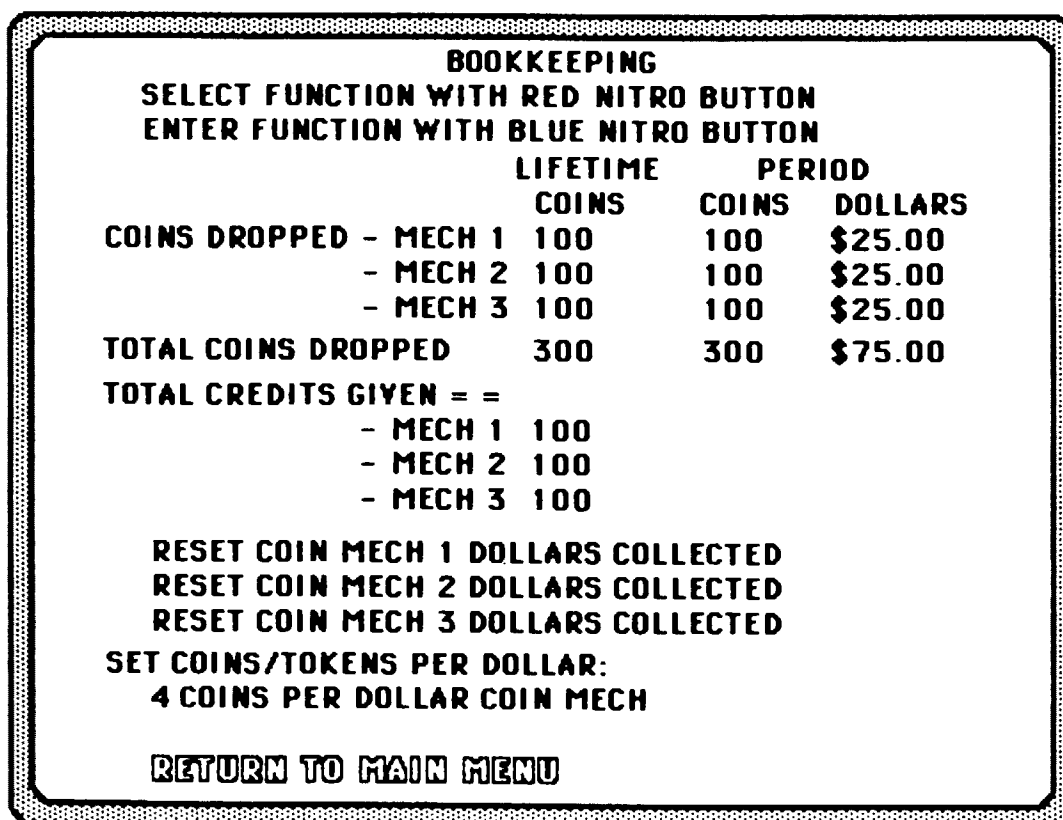

FIGURE 2

**DIAGNOSTICS**

**SELECT FUNCTION WITH RED NITRO BUTTON  
ENTER FUNCTION WITH BLUE NITRO BUTTON**

- BUTTONS AND CONTROLS TEST**
- PROCESSOR MEMORY TEST**
- VIDEO ALIGNMENT SCREENS**
- AUDIO SUBSYSTEMS TEST**
- VIEW BACKGROUND SCREENS**
  
- RETURN TO MAIN MENU**

**FIGURE 3**

**PLEASE PRESS THE FOLLOWING BUTTONS:**

<b>NITRO 1 BUTTON</b>	<b>&lt;RED&gt;</b>	<b>CLOSED</b>
<b>NITRO 2 BUTTON</b>	<b>&lt;YELLOW&gt;</b>	<b>OPEN</b>
<b>NITRO 3 BUTTON</b>	<b>&lt;BLUE&gt;</b>	<b>OPEN</b>
<b>MECH 1 COIN SWITCH</b>		<b>OPEN</b>
<b>MECH 2 COIN SWITCH</b>		<b>OPEN</b>
<b>MECH 3 COIN SWITCH</b>		<b>OPEN</b>
<b>SERVICE SWITCH</b>		<b>OPEN</b>

**INDICATES PRESSED  
OR STUCK SWITCH**

**\*\*\* MINIMUM = 0-80**

**MAXIMUM = 255 \*\*\***

**GAS PEDAL 1**  = 60

**GAS PEDAL 2**  = 72

**GAS PEDAL 3**  = 54

**STEP ON PEDALS TO  
CHECK SETTINGS**

**STEERING WHEEL 1** =

**STEERING WHEEL 2** = **CLOCKWISE TURN**

**STEERING WHEEL 3** = **COUNTER-CLOCKWISE TURN**

**TURN WHEELS TO  
MOVE DIAMONDS**

**PRESS SERVICE OR BLUE NITRO BUTTON TWICE TO EXIT**

**FIGURE 4**

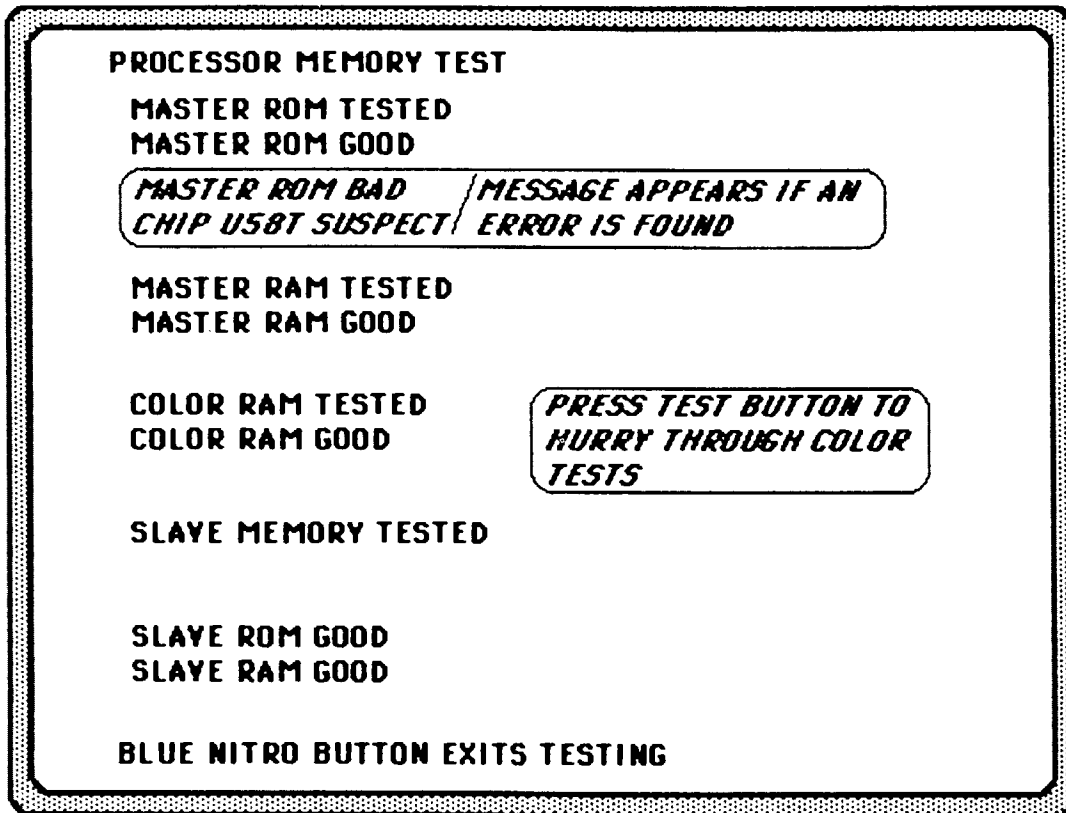

FIGURE 5

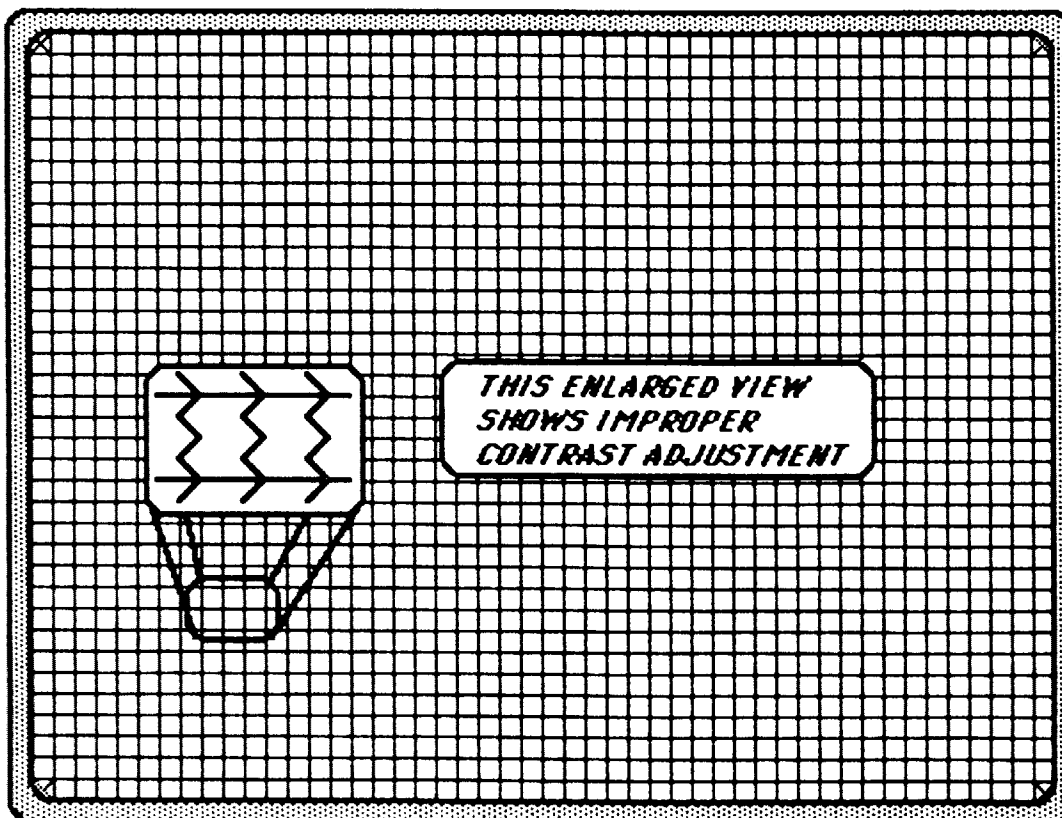

FIGURE 6

## Processor Memory Test (cont.)

The percentage of field failures in these areas is very low, but when a problem does arise, it can be a bear to track down. This test samples the action of the processor section and notes any incongruities.

**WARNING: READ YOUR WARRANTY BEFORE ATTEMPTING ANY PRINTED CIRCUIT BOARD REPAIRS.**

## Video Alignment Screens

The picture on the screen is the most important and most neglected part of the game. It is a proven fact that a dirty, misaligned, or unfocused screen will cause a player to walk away even if the game is his/her favorite piece. A little elbow grease and a couple of minutes spent going through these adjustment screens will make a big difference in the cashbox. Use all three screens to adjust your picture and then go to the "Background Screens" section to make the game look *"rich"*.

### Cross-Hatch Screen (Figure 6)

Used to adjust focus, alignment, size (note x's in the corners) and contrast. Wavy vertical lines (see inset) denote bad contrast.

The background should be black and the lines solid white.

If there appears to be an area of color on the screen (usually in one of the corners), your monitor probably needs "degaussing".

This condition is caused by moving the game with the power on.

Although the monitor contains an internal degaussing mechanism, this mechanism might take a while to work and may not completely cure the problem. I recommend that you purchase a "degaussing coil" and carry it in your service vehicle. Degaussing doesn't take much time and it makes a big difference.

### Red and Green Screen (Figure 7)

Adjust the screen or brightness control so the green color bar shows **faintly** on the 1 level and use the red cutoff control to adjust the red bar to the same intensity.

### Blue and Miscellaneous Screen (Figure 8)

Use the blue cutoff control to make the gray color appear gray (not brownish). Adjust the red and green drive controls slightly, if necessary, to make the white block white.

## Audio Subsystems Test (Figure 9)

The sounds are the second most important feature of any game and in a game like "Super Off-Road" are essential to the feel of the game. The volume of sound is, for the most part, dictated by the location and is thus a "given" but the quality of sound is a function of the program. This test will be of help in your quest to find those "odd" sounds or to remedy the lack of certain sounds.

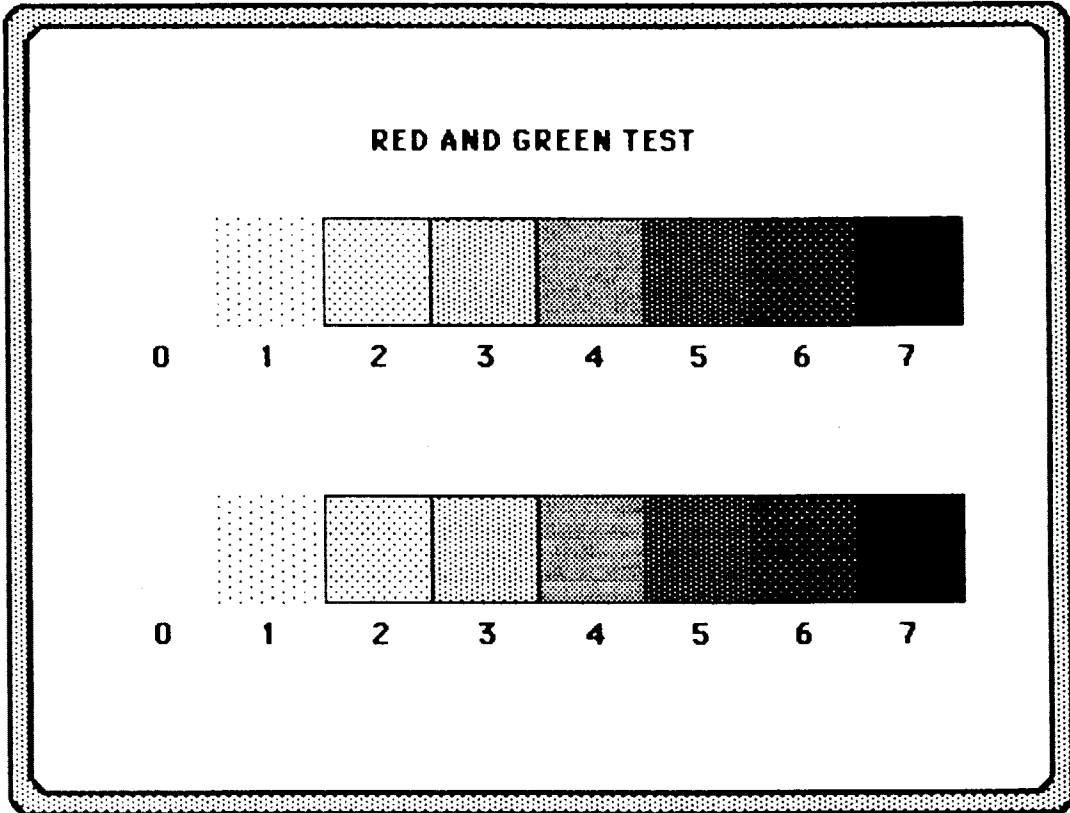

**FIGURE 7**

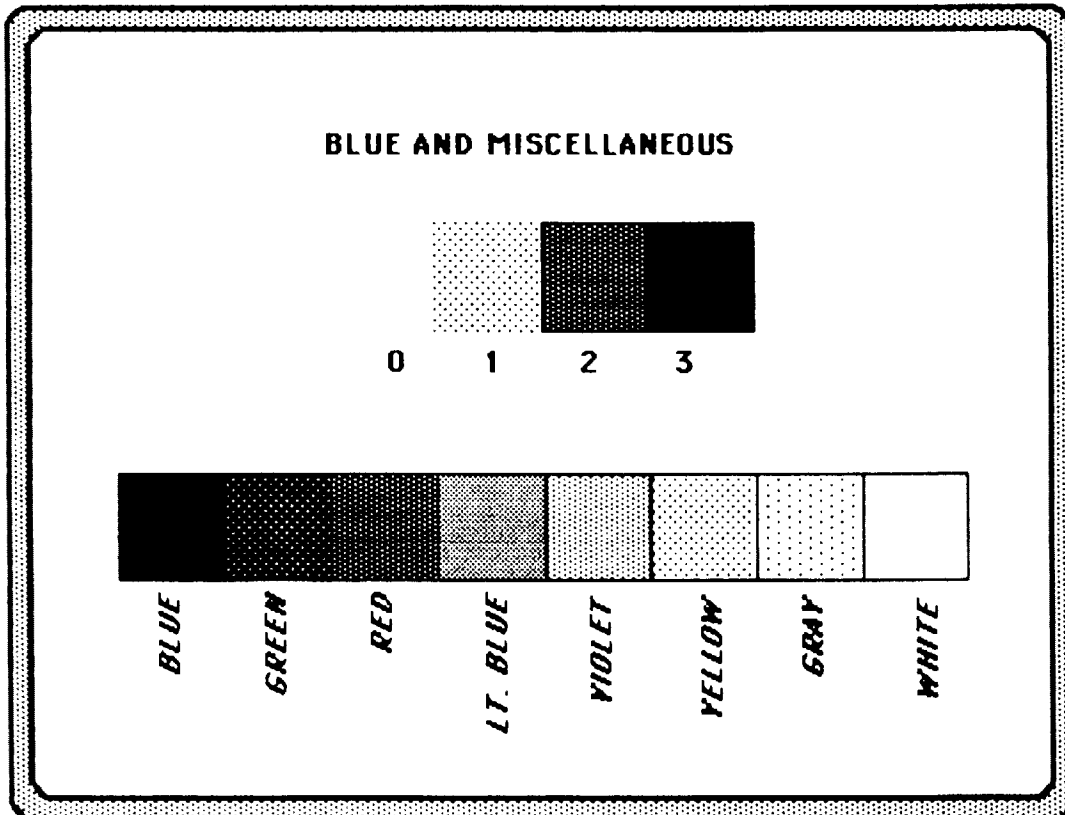

**FIGURE 8**

### **Background Screens** (Figure 10)

In this test, the background screens are shown while the EPROMs which contain the information for these screens are displayed at the top of the picture. This test is not only helpful when looking for those "glitches" one sometimes encounters, but may also be viewed as a visual test of the colors and picture clarity after the "Video Alignment" test has been completed.

### **Game Set-Up** (Figure 11)

The "Game Set-Up" or "Operator Adjustable" section is vital to the condition of your cash box. When used in conjunction with the "Bookkeeping" and "Statistics" sections of this diagnostics package, the "Game Set-Up" function will keep this game on your list of top earners for years to come. The **Coins-per-Credit** settings range from 1 coin for 1 credit to 20 coins for 20 credits. (*0 coins for 1 credit sets the game on "free play".*)

#### **SOME SOUND ADVICE:**

**THOSE ANNOYING ATTRACT MODE SOUNDS ARE SUPPOSED TO DRAW ATTENTION.**

#### **LET THEM !**

The **Difficulty** level may be set from 1 to 8. Our tests show that level **4** is the best all-around starting point.

After entering their initials and birth date each player is asked to choose the country for which he/she will race. The operator may select one of the countries listed to better suit his game to a particular location.

### **Game Statistics** (Figure 12) & **Game Duration Statistics** (Figure 13)

These two sections are your game "Report Card". Check these sections for glaring discrepancies. Many "starts" and few "joins" or "continues" on any one car could be an indication of a control or coin mech problem.

Unlike many games, whose best income is a result of a 2 to 2.5 minute average game time, collections from **"SUPER OFF-ROAD"™** are highest when the average game time is between 3.25 and 3.75 minutes. Your players get more for their money!

### **Country Selection** (Figure 14)

When a player begins a game, he or she is given a choice of countries for whom he or she will race. This section allows you to further customize your game by choosing which eight countries will appear on the country selection screen. You may also choose a preselected list of American or European countries.

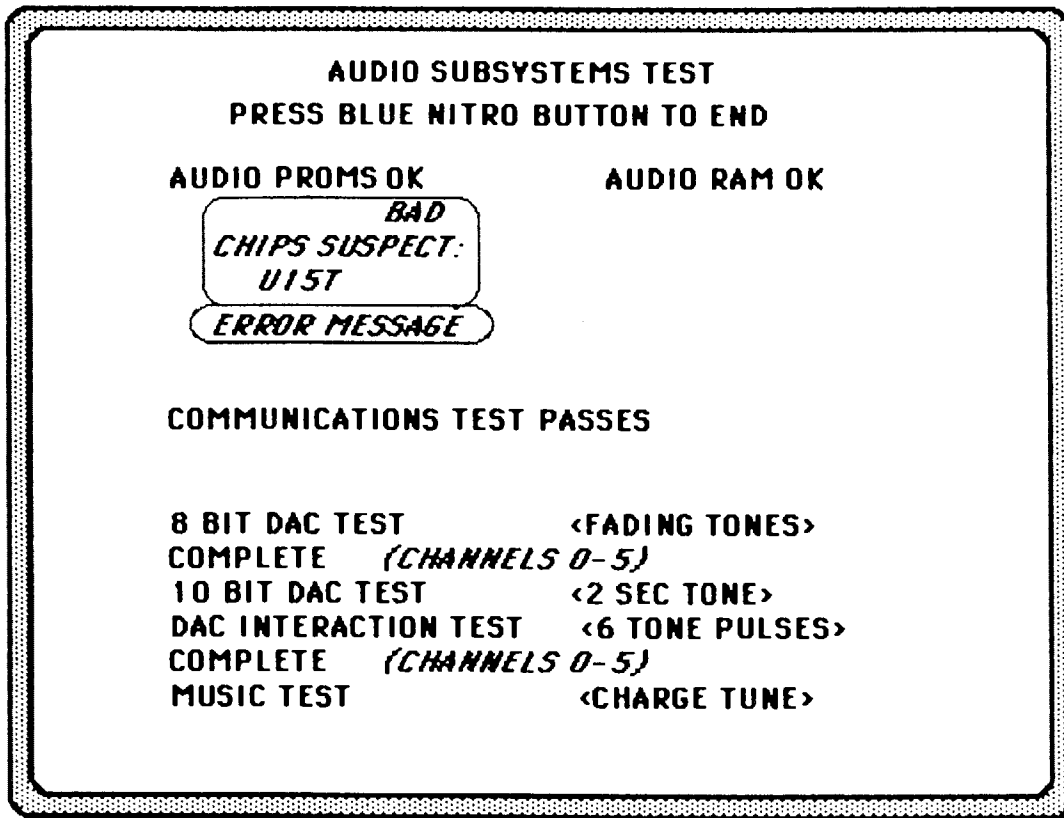

FIGURE 9

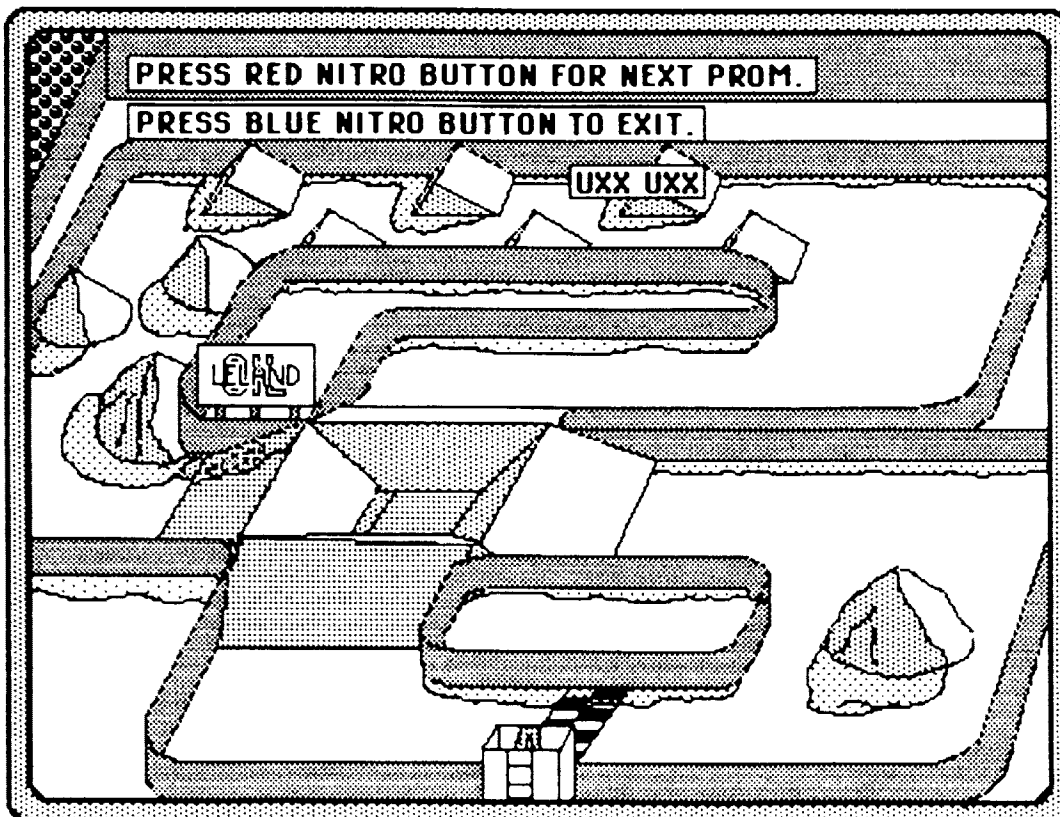

FIGURE 10



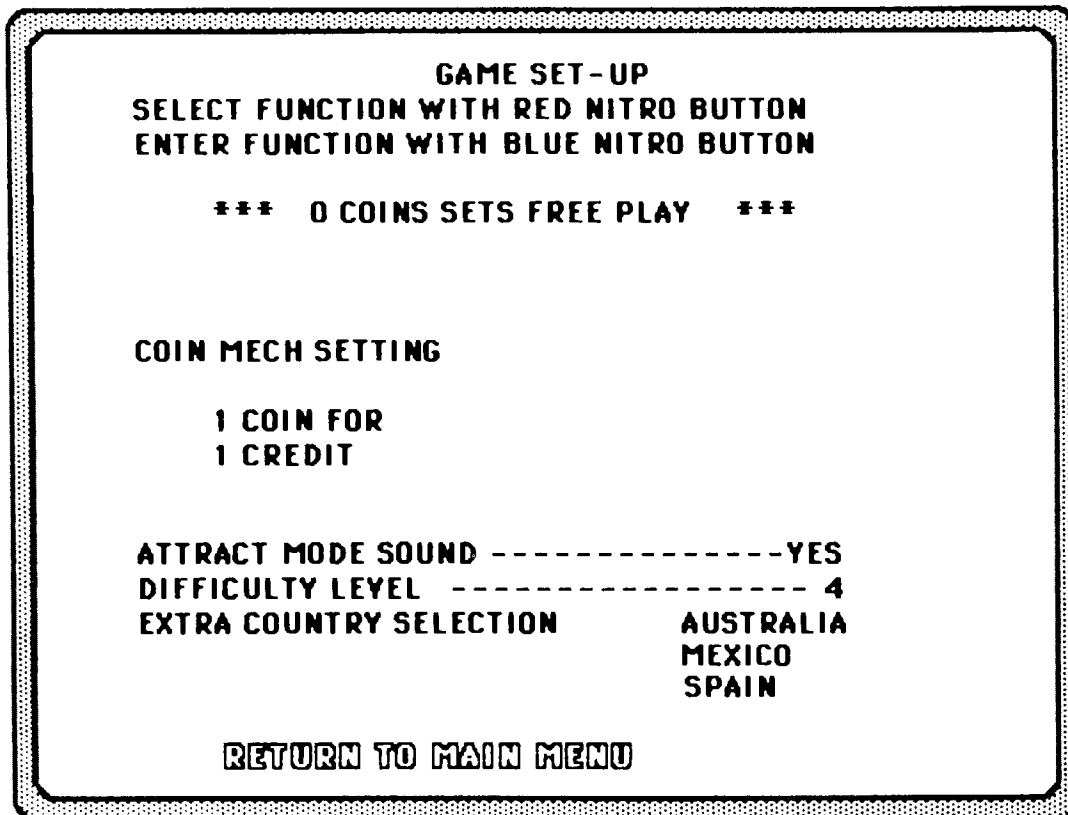

FIGURE 11

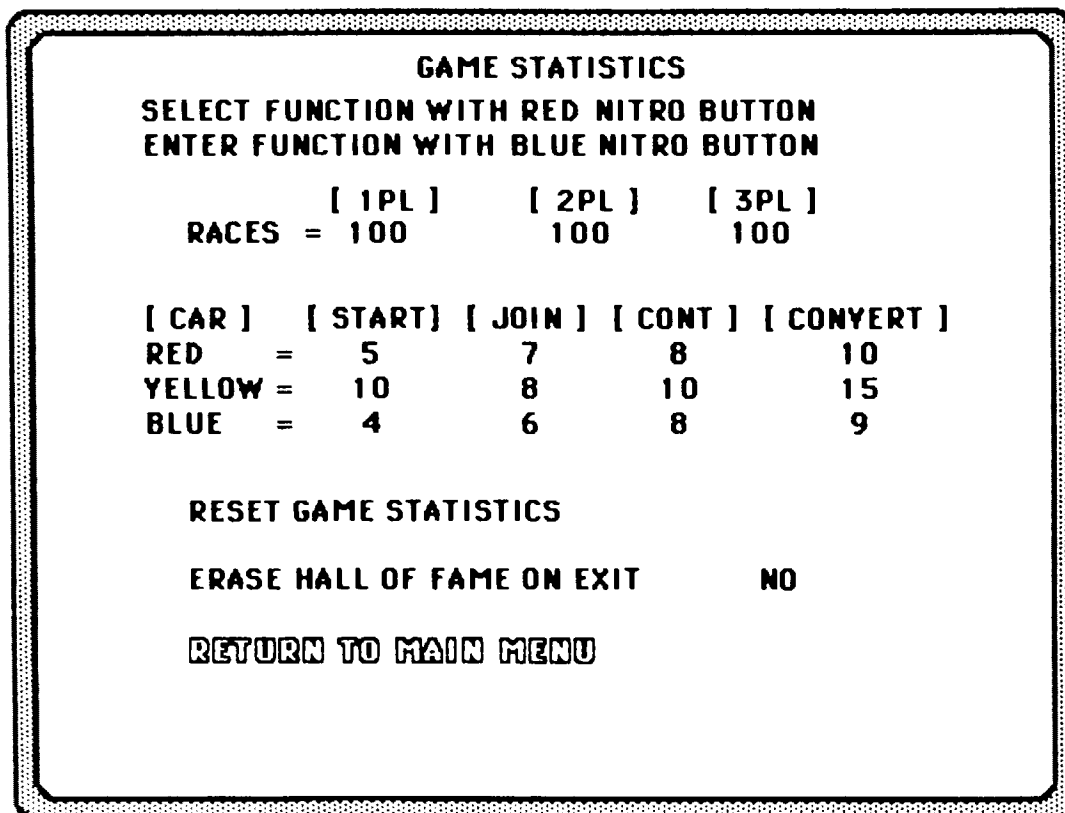

FIGURE 12

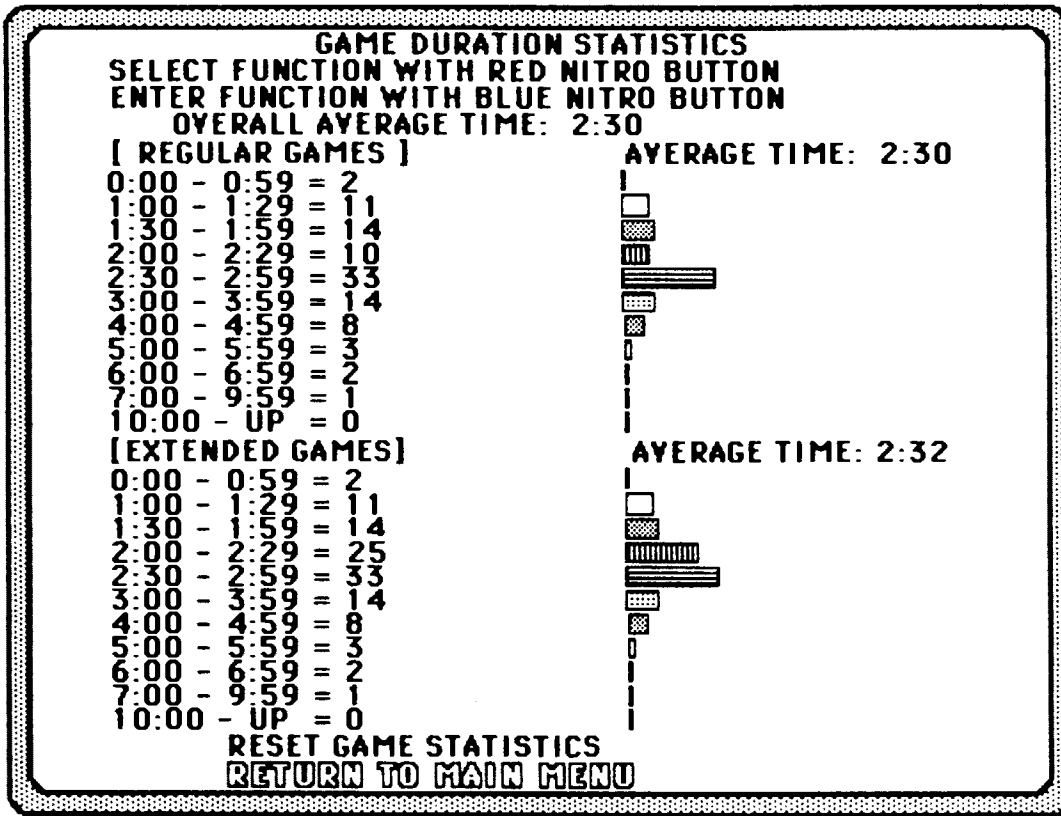

FIGURE 13

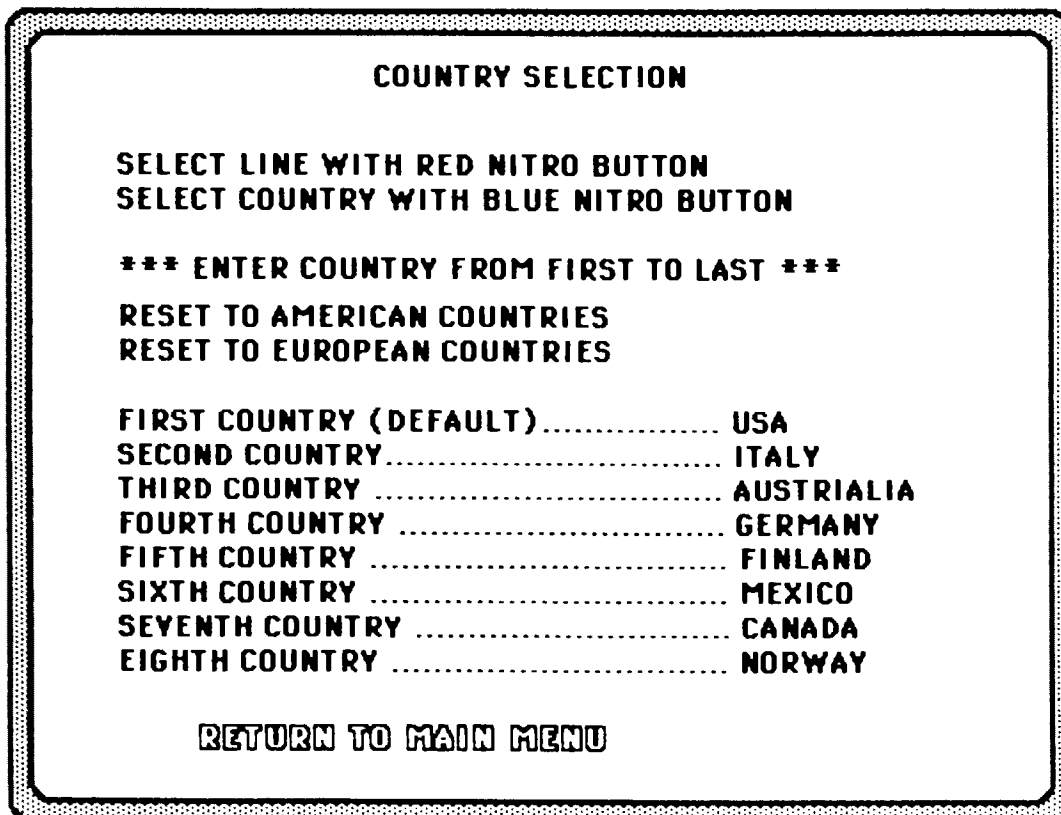
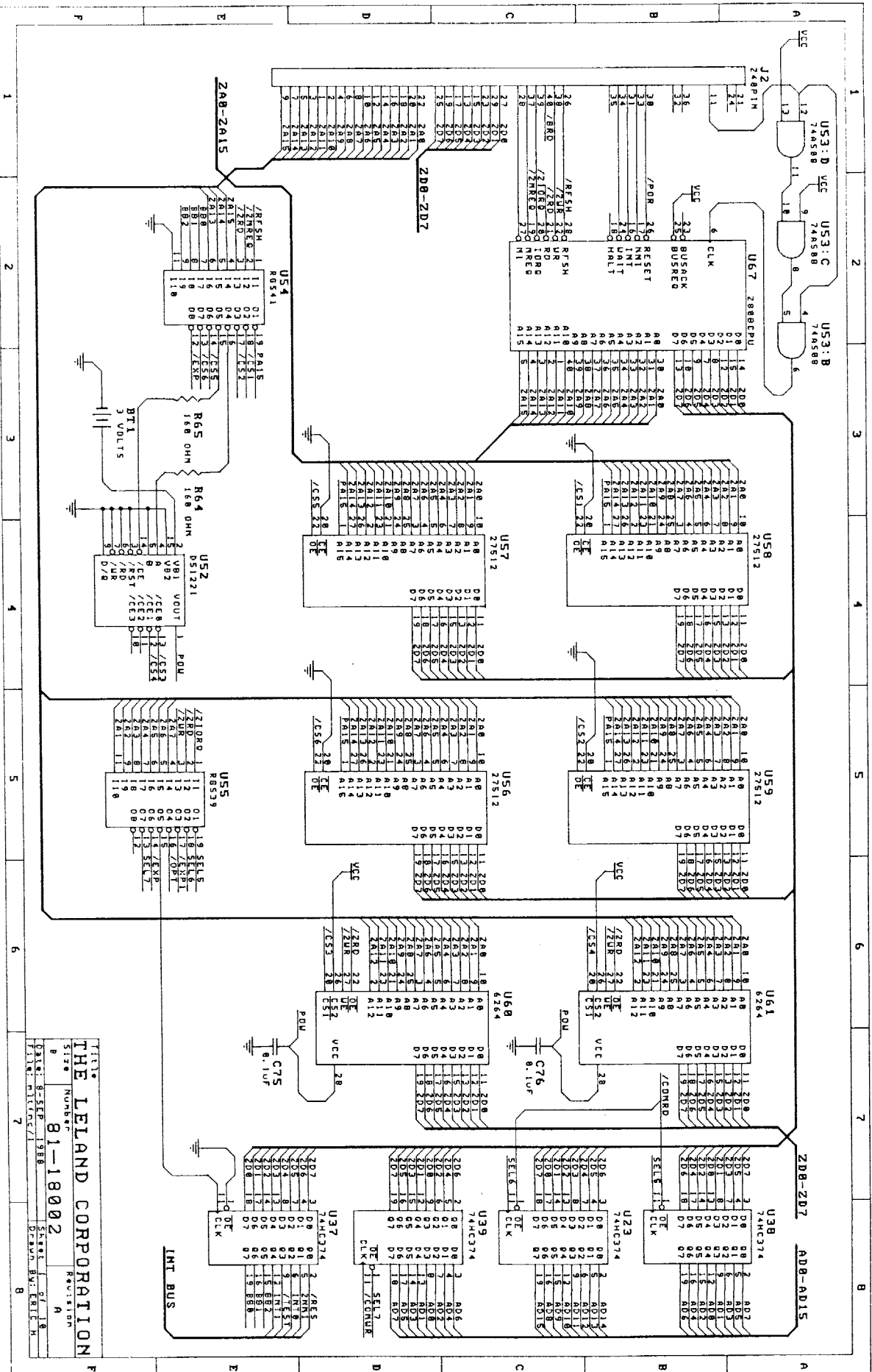

FIGURE 14





THE LELAND CORPORATION  
 81-18002  
 8



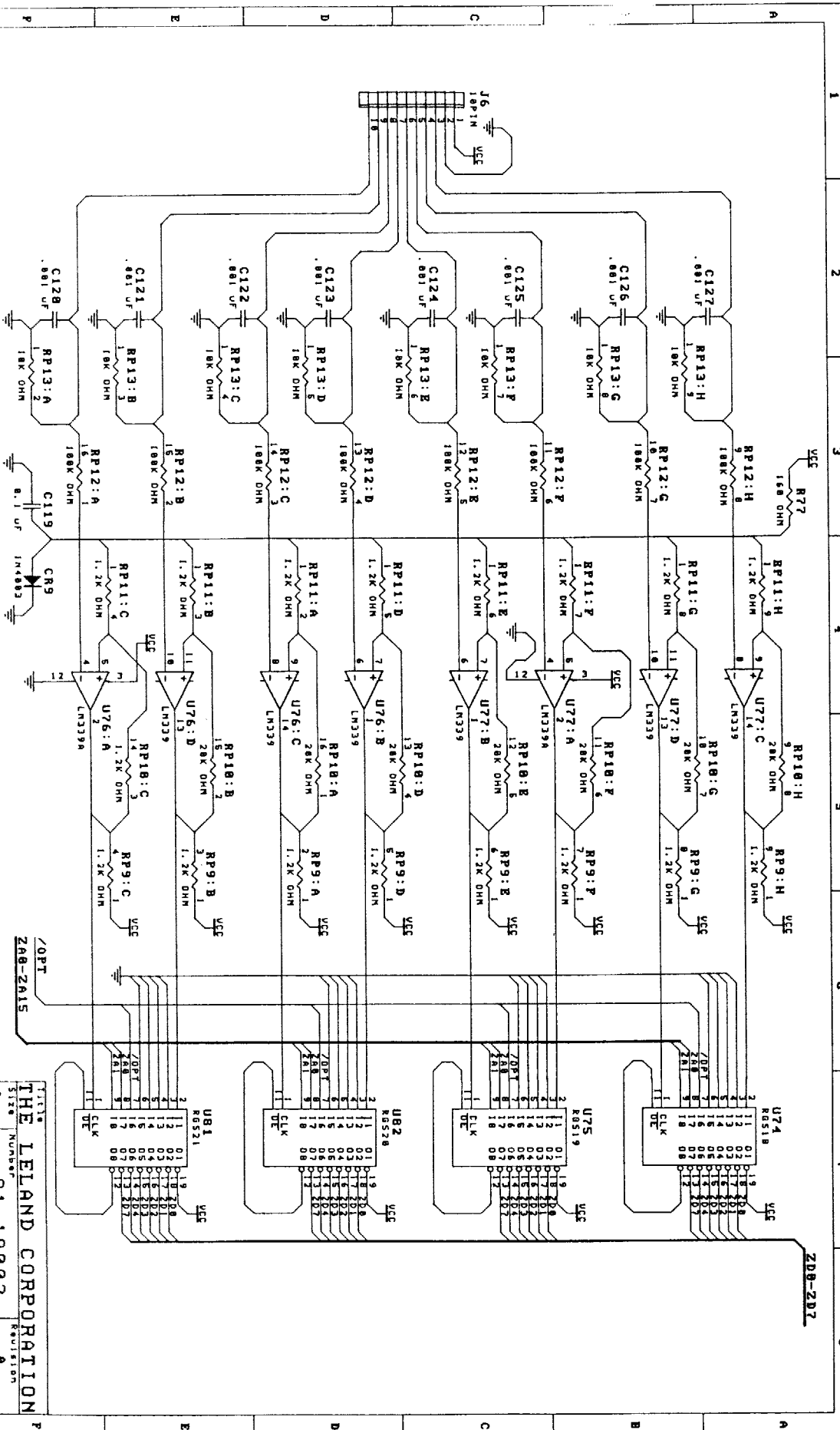

Z08-Z07

THE LELAND CORPORATION  
 Size Number 81-18002  
 DATE: 13-SEP-1988  
 DRAWN BY: ERIC H

U74	1	01	018	20
U74	2	02	017	20
U74	3	03	016	20
U74	4	04	015	20
U74	5	05	014	20
U74	6	06	013	20
U74	7	07	012	20
U74	8	08	011	20
U74	9	09	010	20
U74	10	10	009	20
U74	11	11	008	20
U74	12	12	007	20
U74	13	13	006	20
U74	14	14	005	20
U74	15	15	004	20
U74	16	16	003	20
U74	17	17	002	20
U74	18	18	001	20
U74	19	19	000	20
U74	20	20	000	20

U75	1	01	018	20
U75	2	02	017	20
U75	3	03	016	20
U75	4	04	015	20
U75	5	05	014	20
U75	6	06	013	20
U75	7	07	012	20
U75	8	08	011	20
U75	9	09	010	20
U75	10	10	009	20
U75	11	11	008	20
U75	12	12	007	20
U75	13	13	006	20
U75	14	14	005	20
U75	15	15	004	20
U75	16	16	003	20
U75	17	17	002	20
U75	18	18	001	20
U75	19	19	000	20
U75	20	20	000	20

U76	1	01	018	20
U76	2	02	017	20
U76	3	03	016	20
U76	4	04	015	20
U76	5	05	014	20
U76	6	06	013	20
U76	7	07	012	20
U76	8	08	011	20
U76	9	09	010	20
U76	10	10	009	20
U76	11	11	008	20
U76	12	12	007	20
U76	13	13	006	20
U76	14	14	005	20
U76	15	15	004	20
U76	16	16	003	20
U76	17	17	002	20
U76	18	18	001	20
U76	19	19	000	20
U76	20	20	000	20

U77	1	01	018	20
U77	2	02	017	20
U77	3	03	016	20
U77	4	04	015	20
U77	5	05	014	20
U77	6	06	013	20
U77	7	07	012	20
U77	8	08	011	20
U77	9	09	010	20
U77	10	10	009	20
U77	11	11	008	20
U77	12	12	007	20
U77	13	13	006	20
U77	14	14	005	20
U77	15	15	004	20
U77	16	16	003	20
U77	17	17	002	20
U77	18	18	001	20
U77	19	19	000	20
U77	20	20	000	20

U81	1	01	018	20
U81	2	02	017	20
U81	3	03	016	20
U81	4	04	015	20
U81	5	05	014	20
U81	6	06	013	20
U81	7	07	012	20
U81	8	08	011	20
U81	9	09	010	20
U81	10	10	009	20
U81	11	11	008	20
U81	12	12	007	20
U81	13	13	006	20
U81	14	14	005	20
U81	15	15	004	20
U81	16	16	003	20
U81	17	17	002	20
U81	18	18	001	20
U81	19	19	000	20
U81	20	20	000	20

U82	1	01	018	20
U82	2	02	017	20
U82	3	03	016	20
U82	4	04	015	20
U82	5	05	014	20
U82	6	06	013	20
U82	7	07	012	20
U82	8	08	011	20
U82	9	09	010	20
U82	10	10	009	20
U82	11	11	008	20
U82	12	12	007	20
U82	13	13	006	20
U82	14	14	005	20
U82	15	15	004	20
U82	16	16	003	20
U82	17	17	002	20
U82	18	18	001	20
U82	19	19	000	20
U82	20	20	000	20

U8521	1	01	018	20
U8521	2	02	017	20
U8521	3	03	016	20
U8521	4	04	015	20
U8521	5	05	014	20
U8521	6	06	013	20
U8521	7	07	012	20
U8521	8	08	011	20
U8521	9	09	010	20
U8521	10	10	009	20
U8521	11	11	008	20
U8521	12	12	007	20
U8521	13	13	006	20
U8521	14	14	005	20
U8521	15	15	004	20
U8521	16	16	003	20
U8521	17	17	002	20
U8521	18	18	001	20
U8521	19	19	000	20
U8521	20	20	000	20

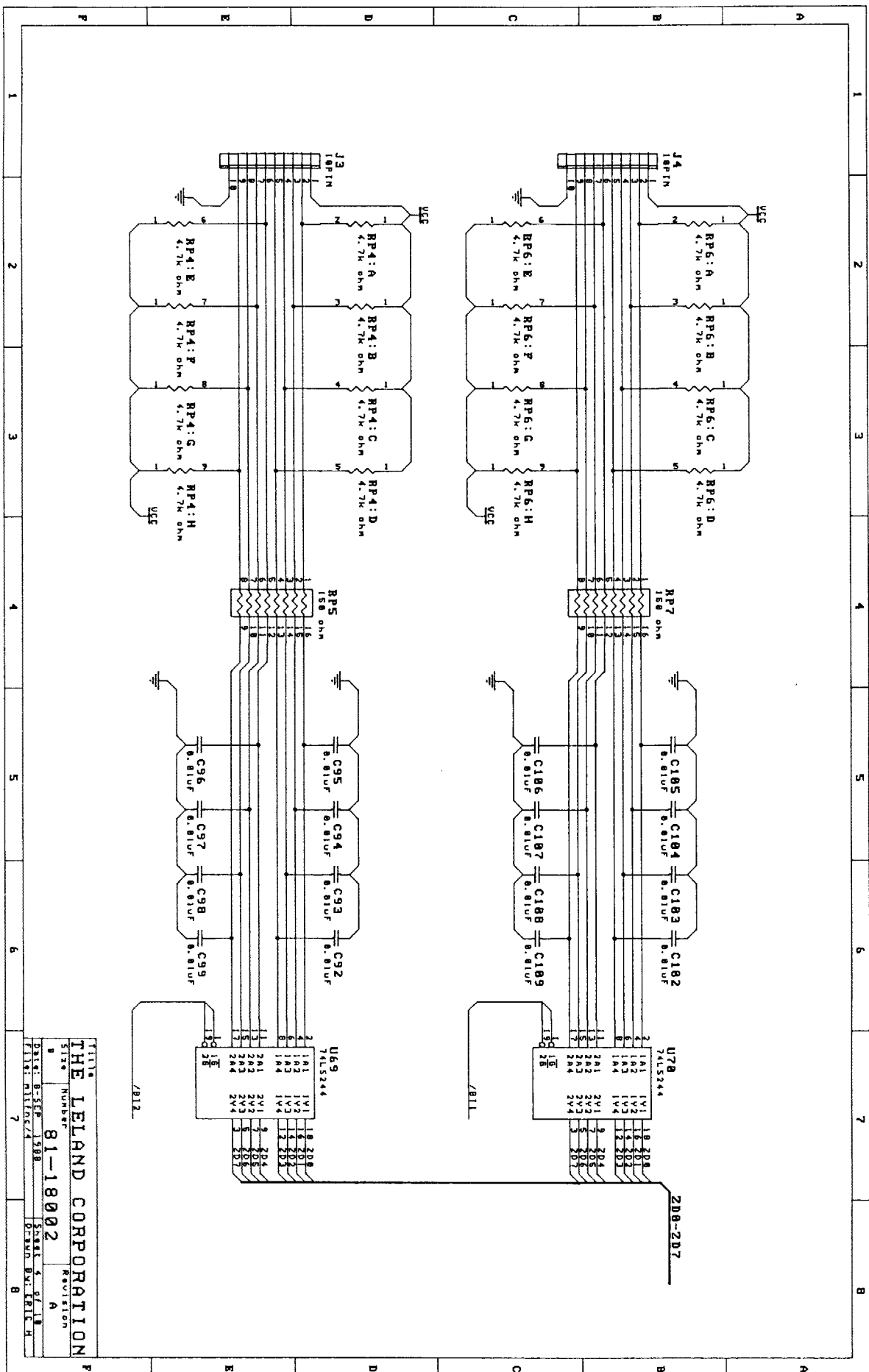

**THE IRLAND CORPORATION**  
 TITLE: 81-18002  
 SIZE: 8-SEP-1988  
 PART: 81-18002  
 FILE: 81-18002/4  
 DRAWN BY: J. KELLY  
 REVISION: A  
 DATE: 8-SEP-1988  
 CHECKED BY: J. KELLY  
 APPROVED BY: J. KELLY







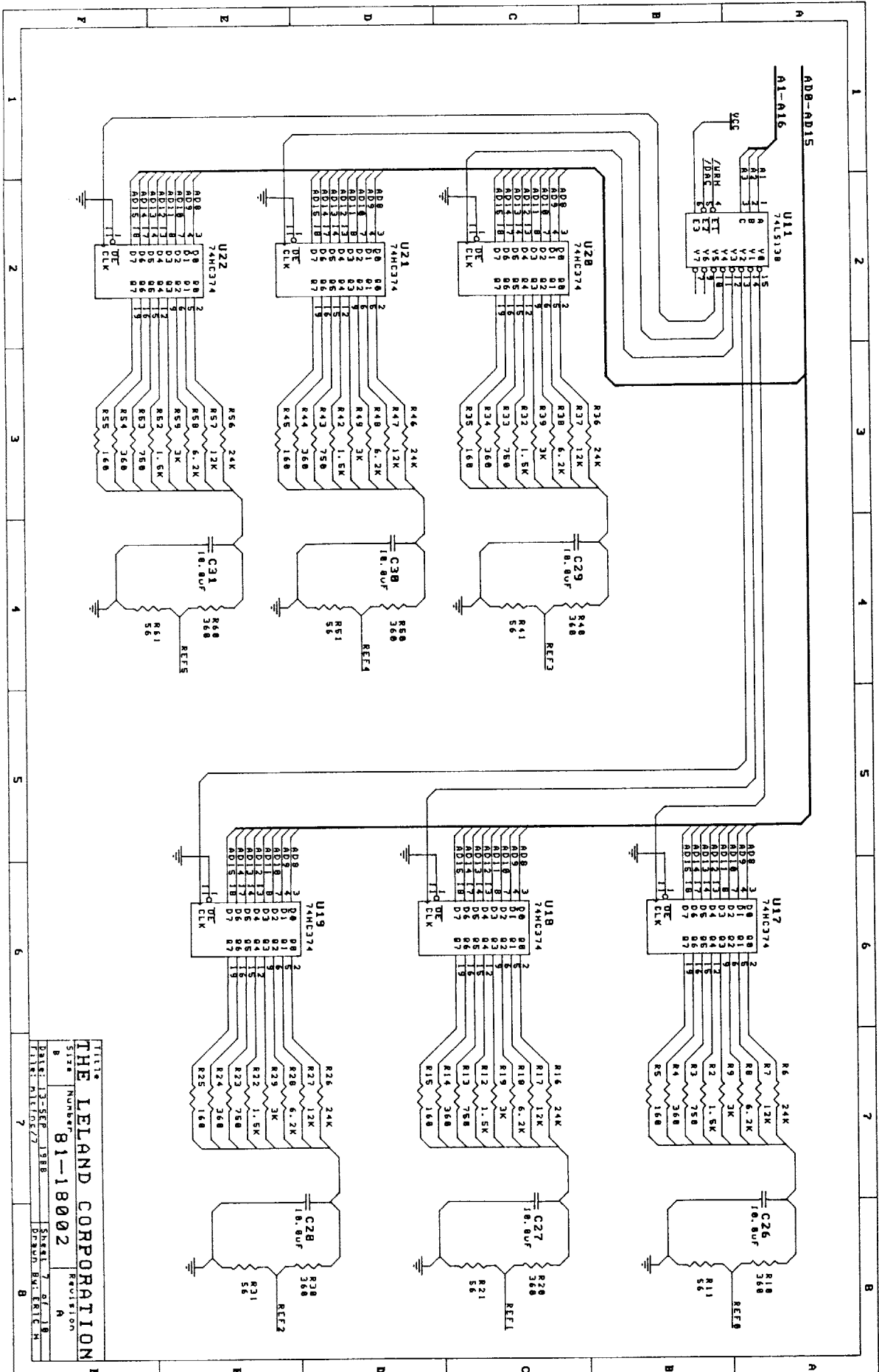

TITLE: THE TELAND CORPORATION  
 Size: 81-18002  
 DATE: 12-SEP-1988  
 FILE: M170277  
 REV: 7  
 SHEET NO. 1  
 OF 1

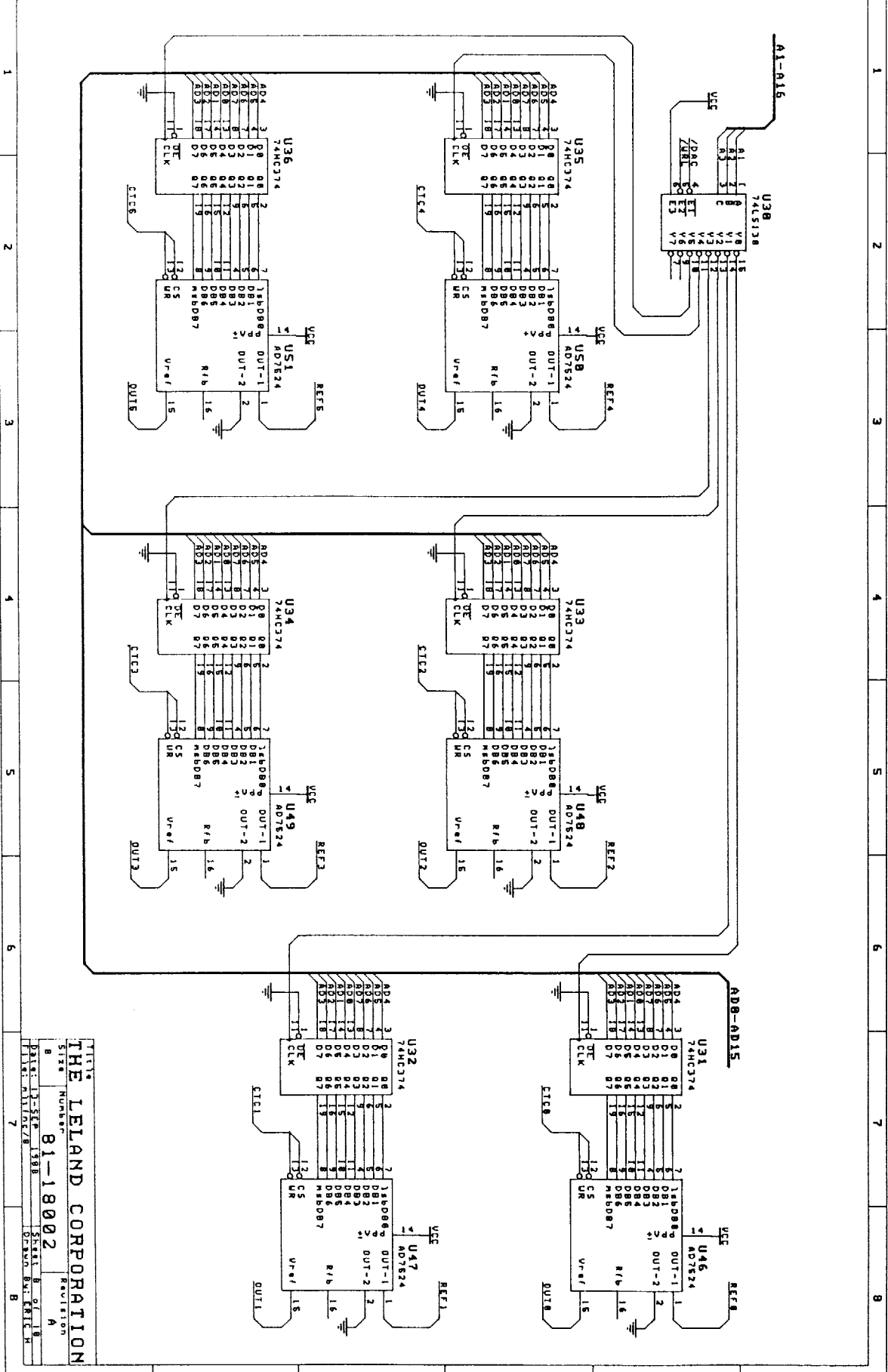

TITLE  
**THE ISLAND CORPORATION**  
 SIZE NUMBER  
**81-18002**  
 DATE: 13-SEP-1988  
 DRAWN BY: KEITH  
 CHECKED BY: KEITH  
 REVISION  
 A  
 B

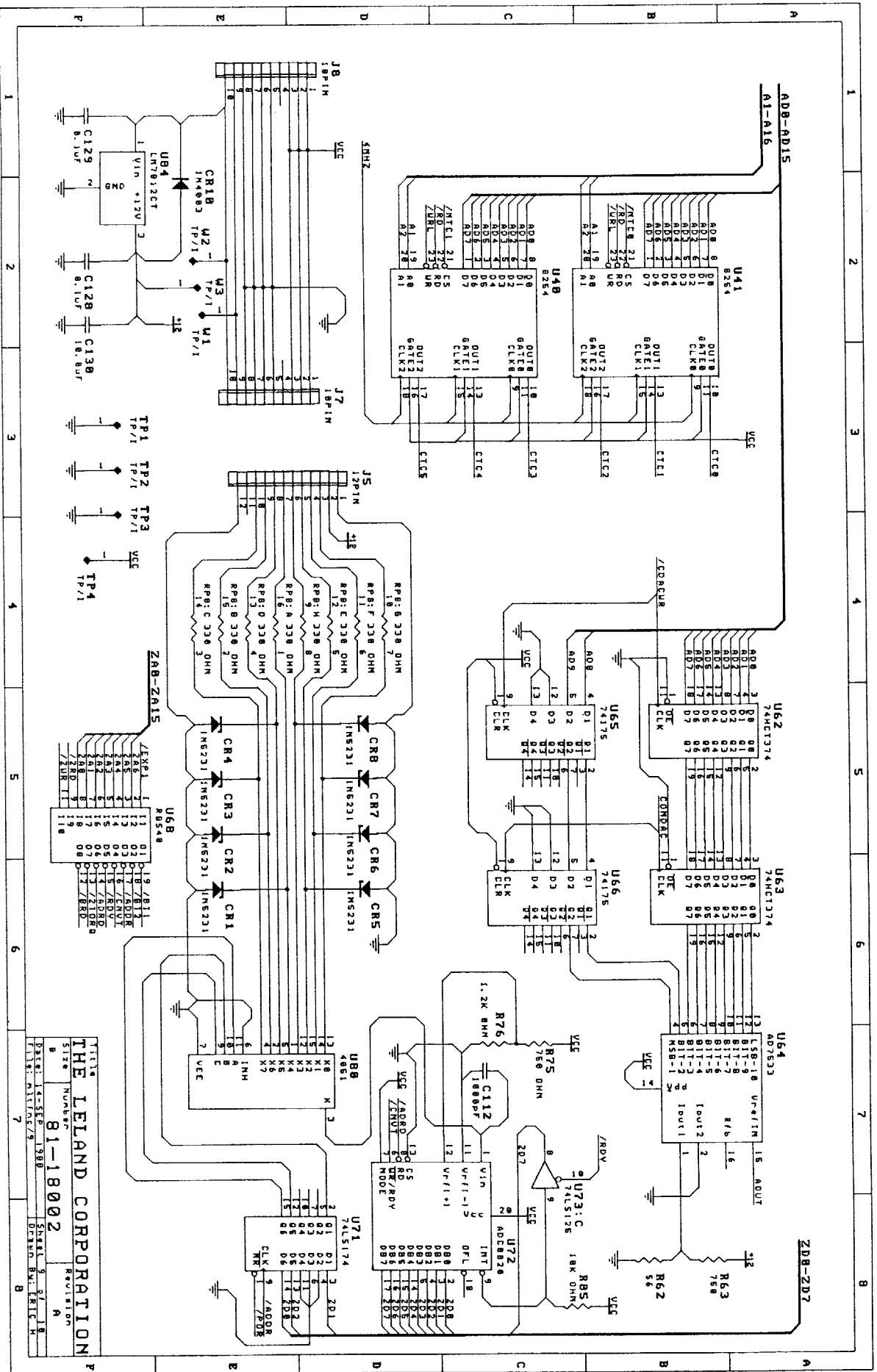

**TITLE**  
**THE IELAND CORPORATION**  
**81-18002**  
**REVISION**  
**REV. 5 OF 18**  
**DATE: 11-15-78**  
**DESIGNER: B. J. B. / S. H.**  
**CHECKER: B. J. B. / S. H.**  
**DATE: 11-15-78**  
**BY: B. J. B. / S. H.**

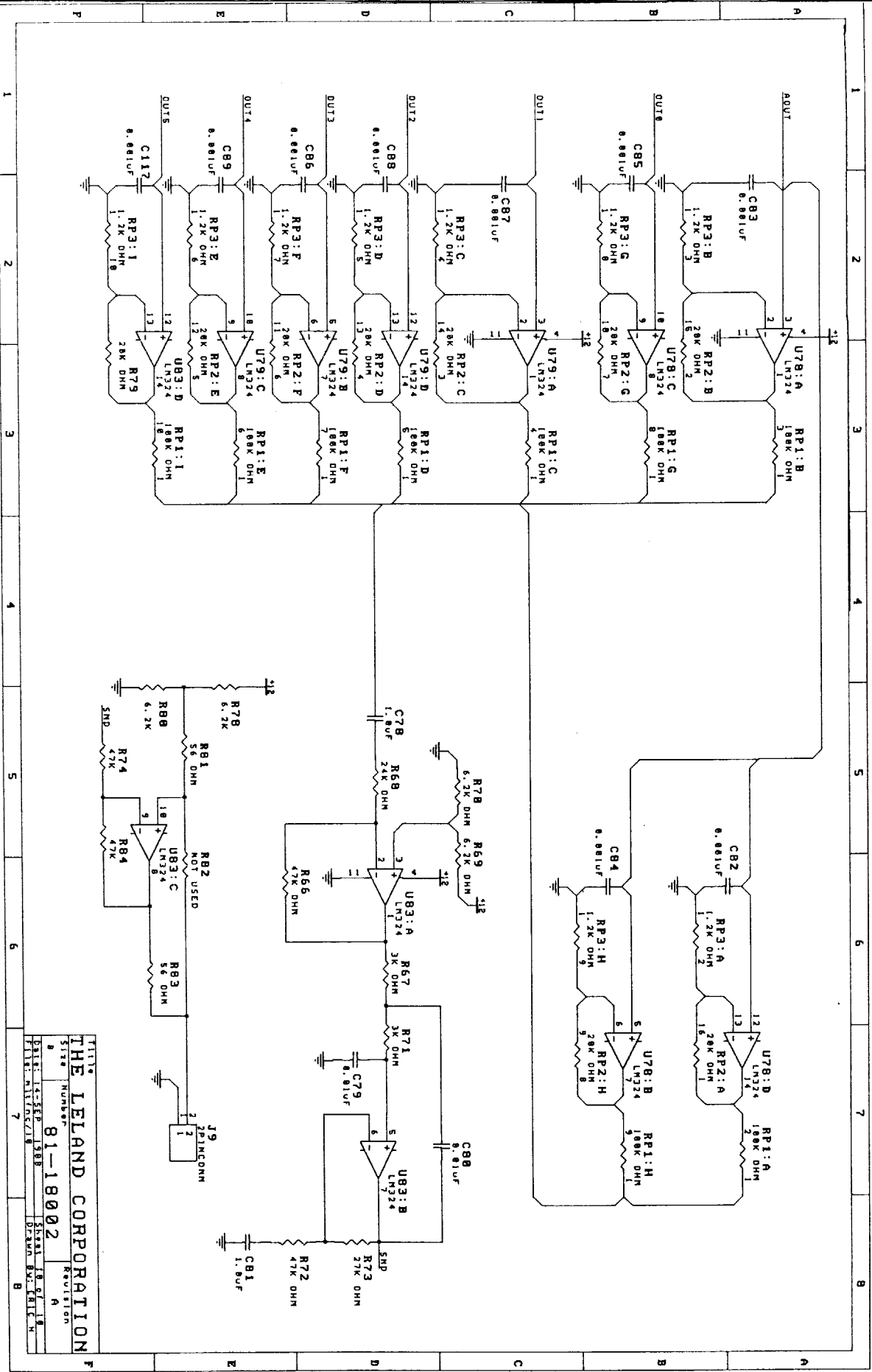

TITLE  
**THE LELAND CORPORATION**  
 DRAWING NUMBER  
**81-18002**  
 DATE: 14-SEP-58  
 SHEET 18 OF 18  
 FILE: M1700/18  
 DRAWN BY: ERIC M.



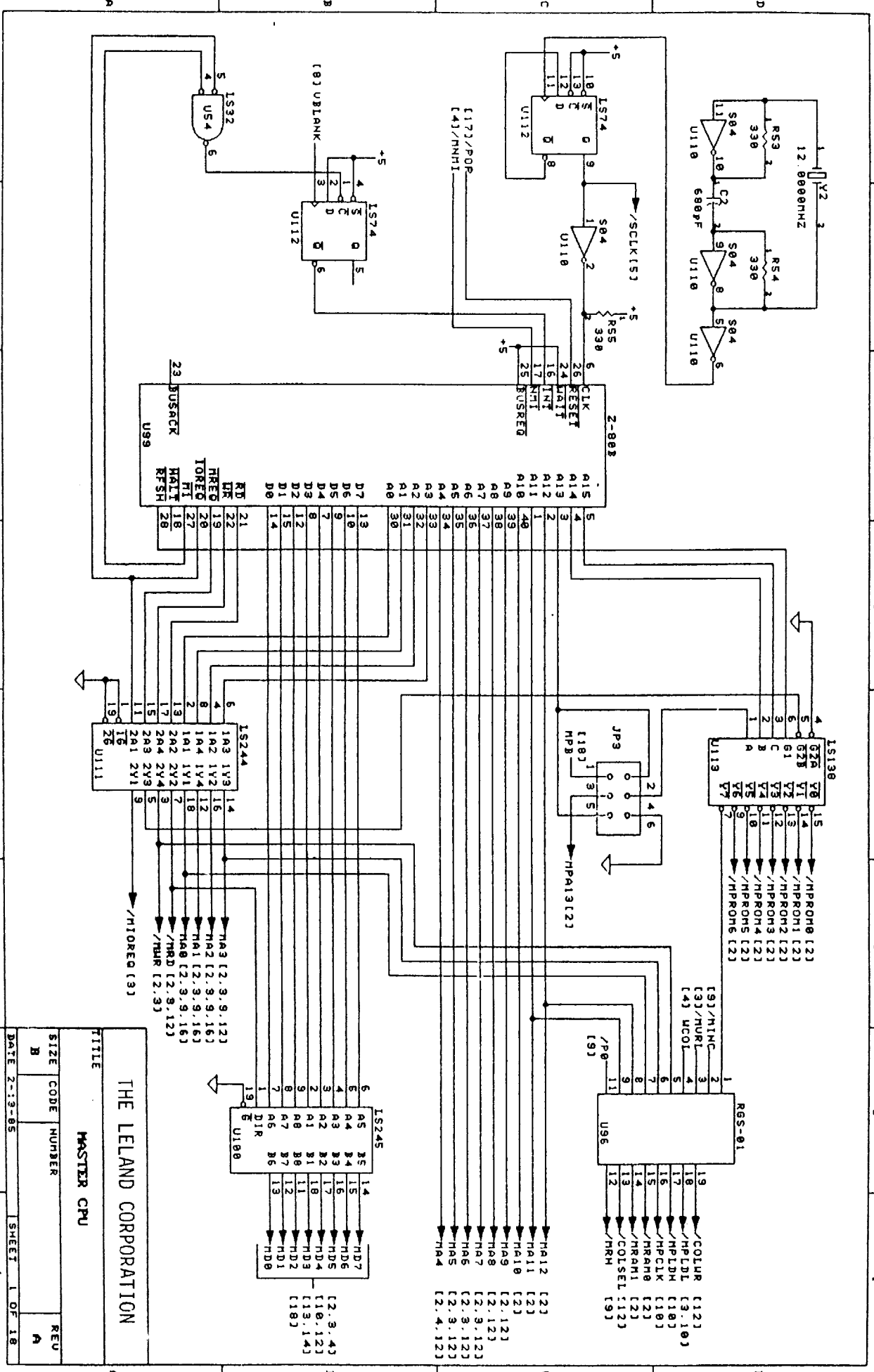

TITLE		THE LELAND CORPORATION	
MASTER CPU			
SIZE	CODE	NUMBER	REV
B			A
DATE 2-13-85		SHEET 1 OF 18	





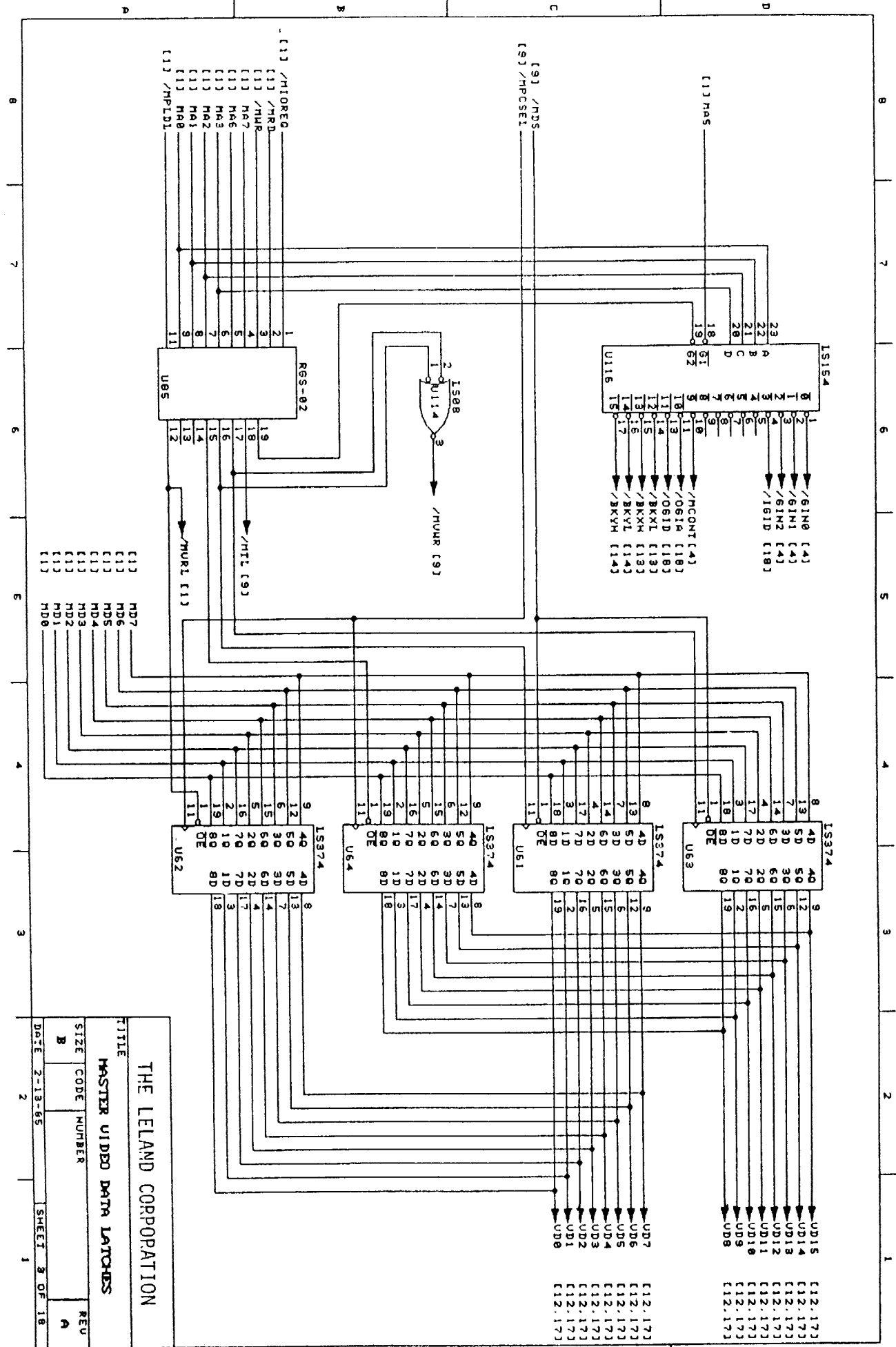

**THE LELAND CORPORATION**

**MASTER UIDED DATA LATCHES**

TITLE	REV
MASTER UIDED DATA LATCHES	A
SIZE CODE NUMBER	
B	
DATE 2-13-85	SHEET 3 OF 18

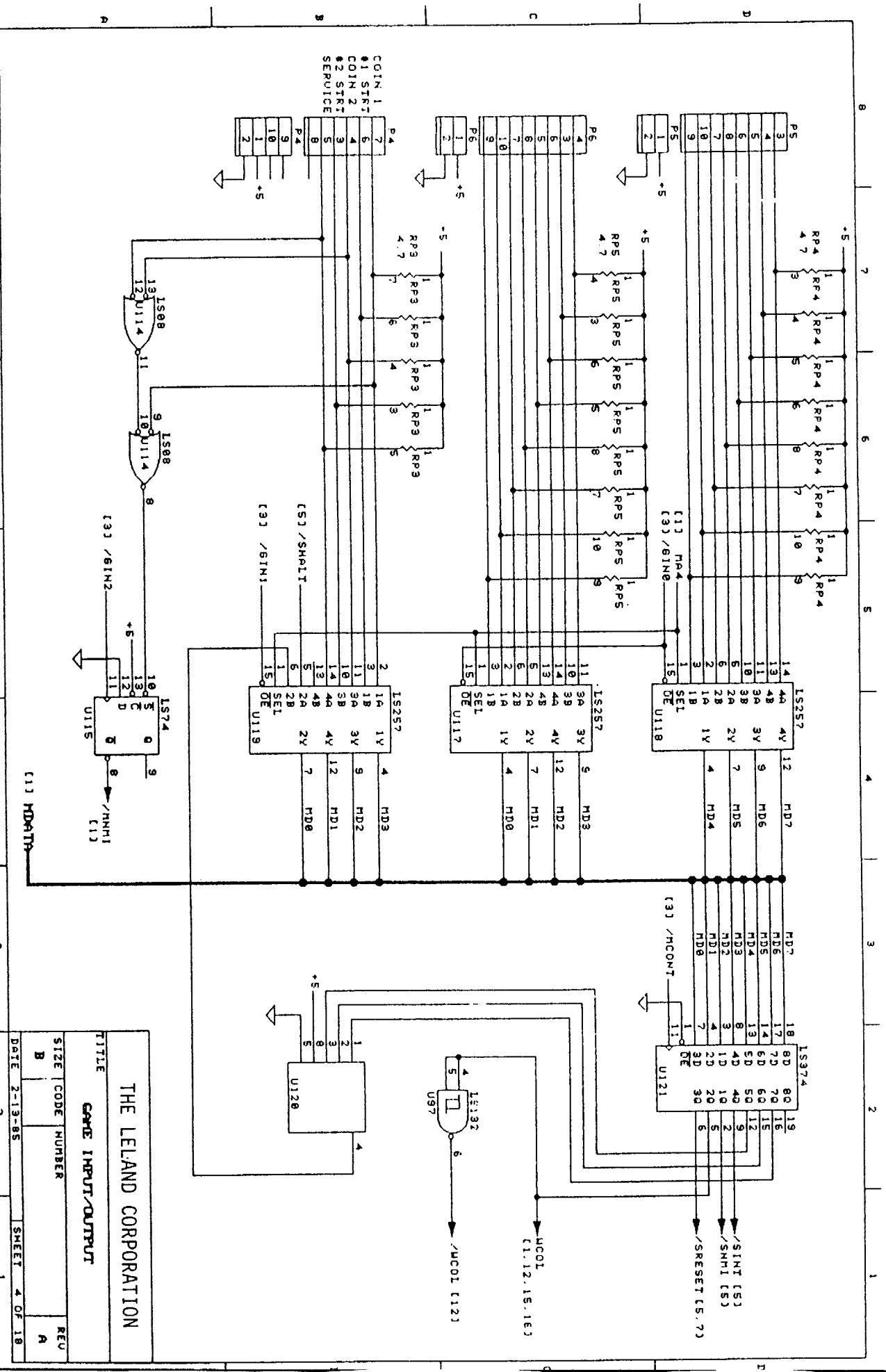

**THE LELAND CORPORATION**  
**GAME INPUT/OUTPUT**  
 TITLE  
 SIZE CODE NUMBER  
 B  
 REV A  
 DATE 2-13-85 SHEET 4 OF 18

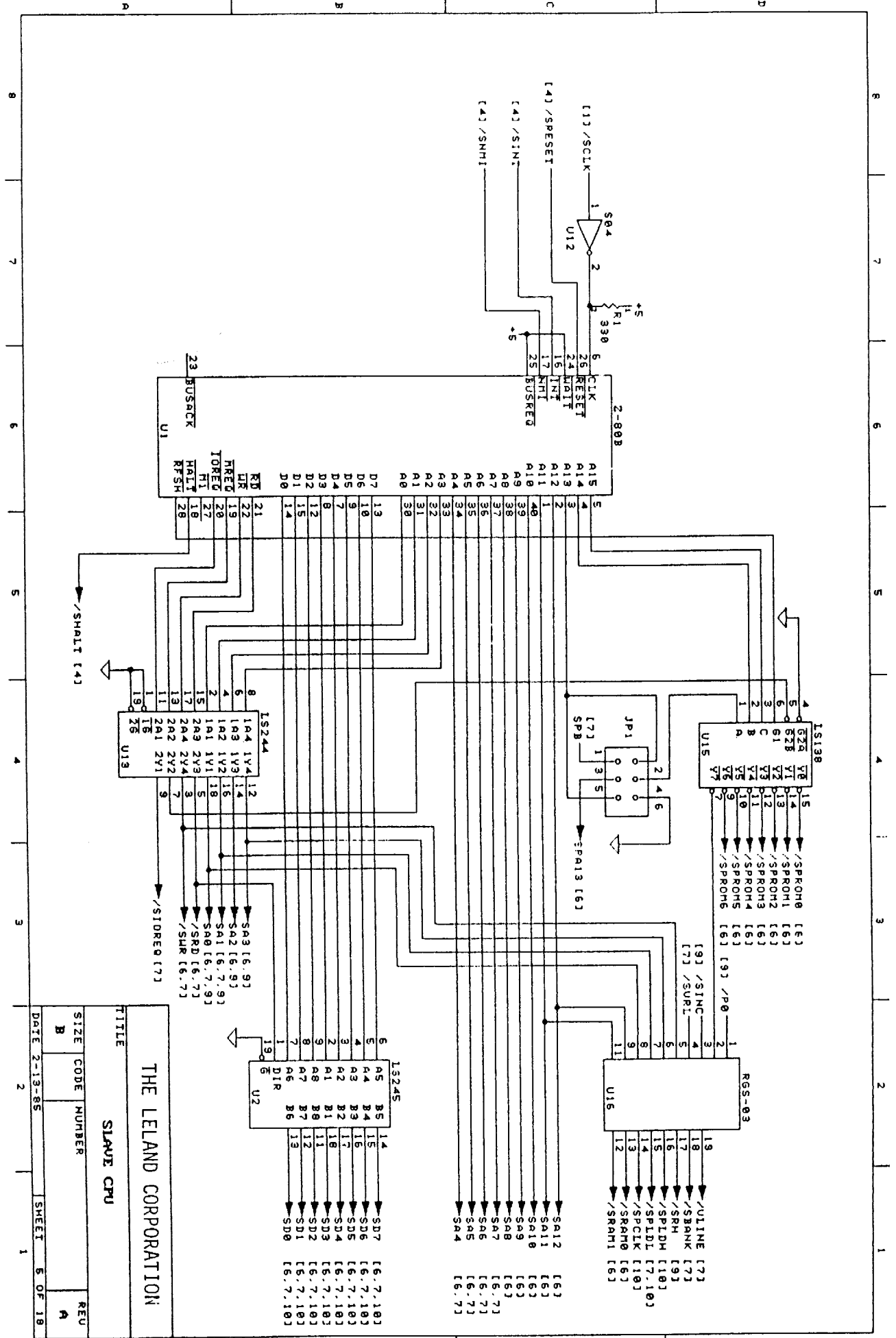

TITLE THE LELAND CORPORATION  
 SLAVE CPU  
 SIZE CODE NUMBER REU  
 B A  
 DATE 2-13-85 SHEET 6 OF 18

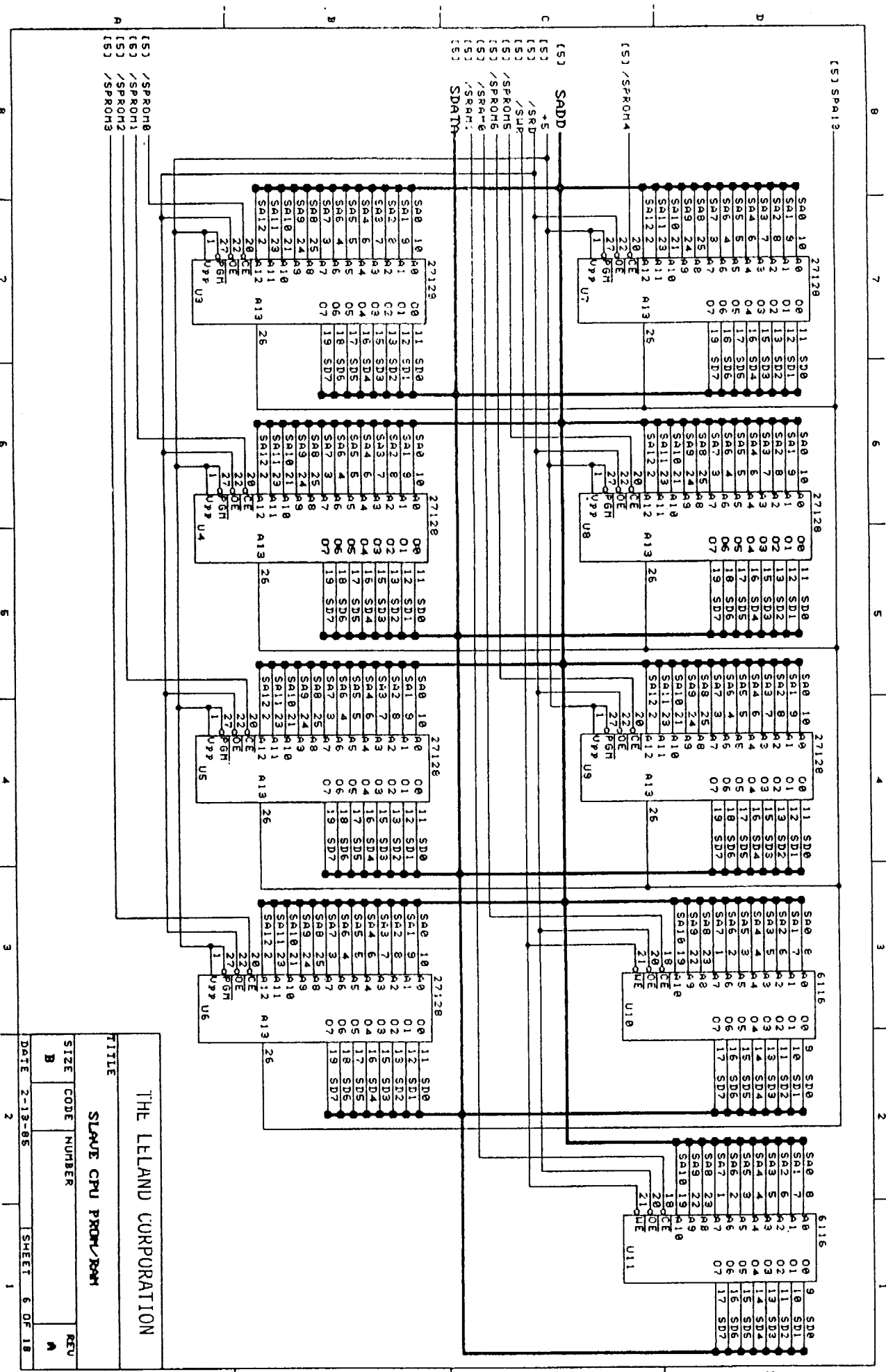

THE LELAND CORPORATION

SLAVE CPU PROM/ROM

TITLE

SIZE CODE NUMBER

REV A

DATE 2-13-85 SHEET 6 OF 18

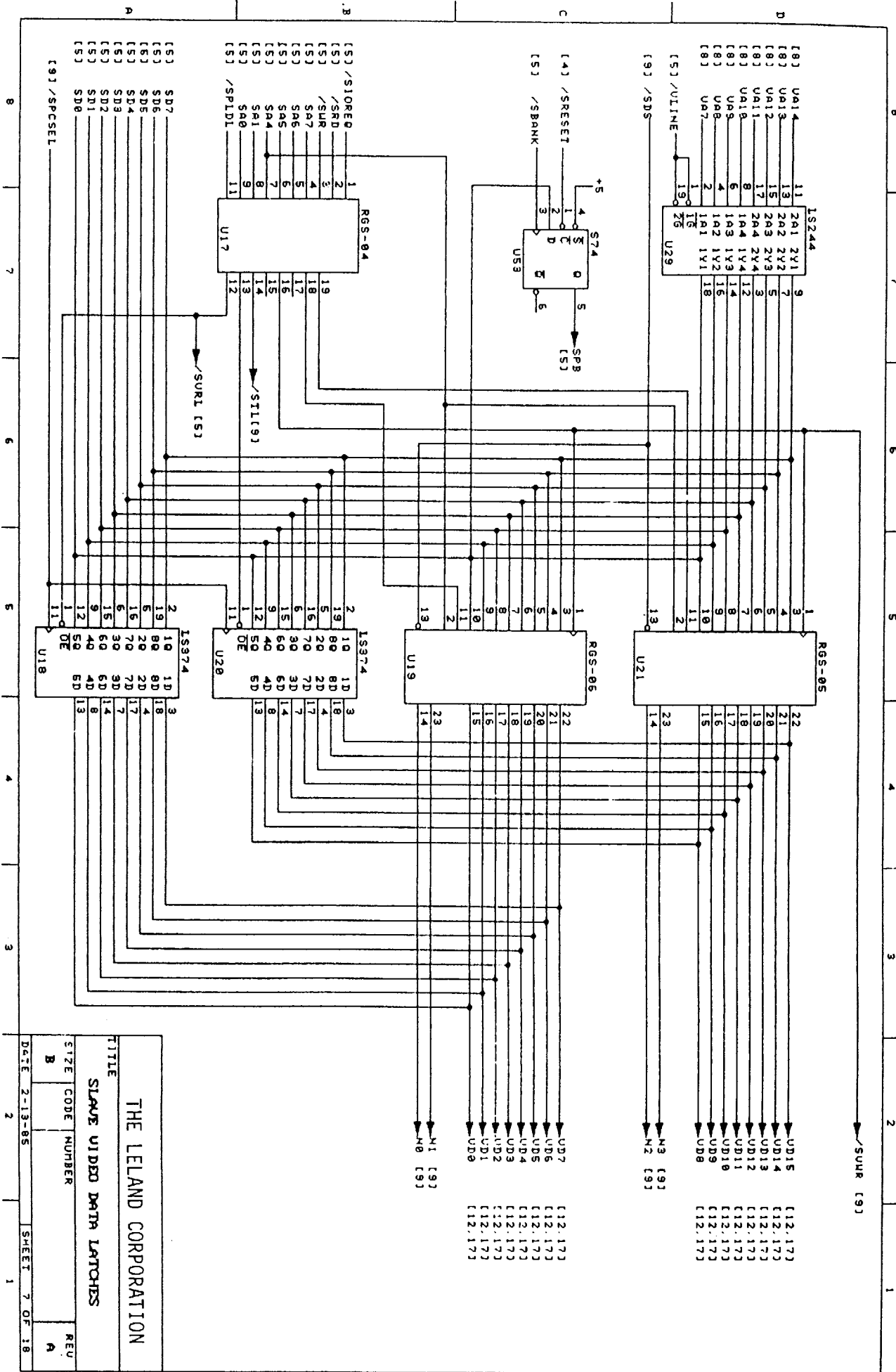

<b>THE LELAND CORPORATION</b>			
<b>SLAVE U100 DATA LATCHES</b>			
TITLE			
SIZE	CODE	NUMBER	REV
B			A
DATE	2-13-85	SHEET	7 OF 18

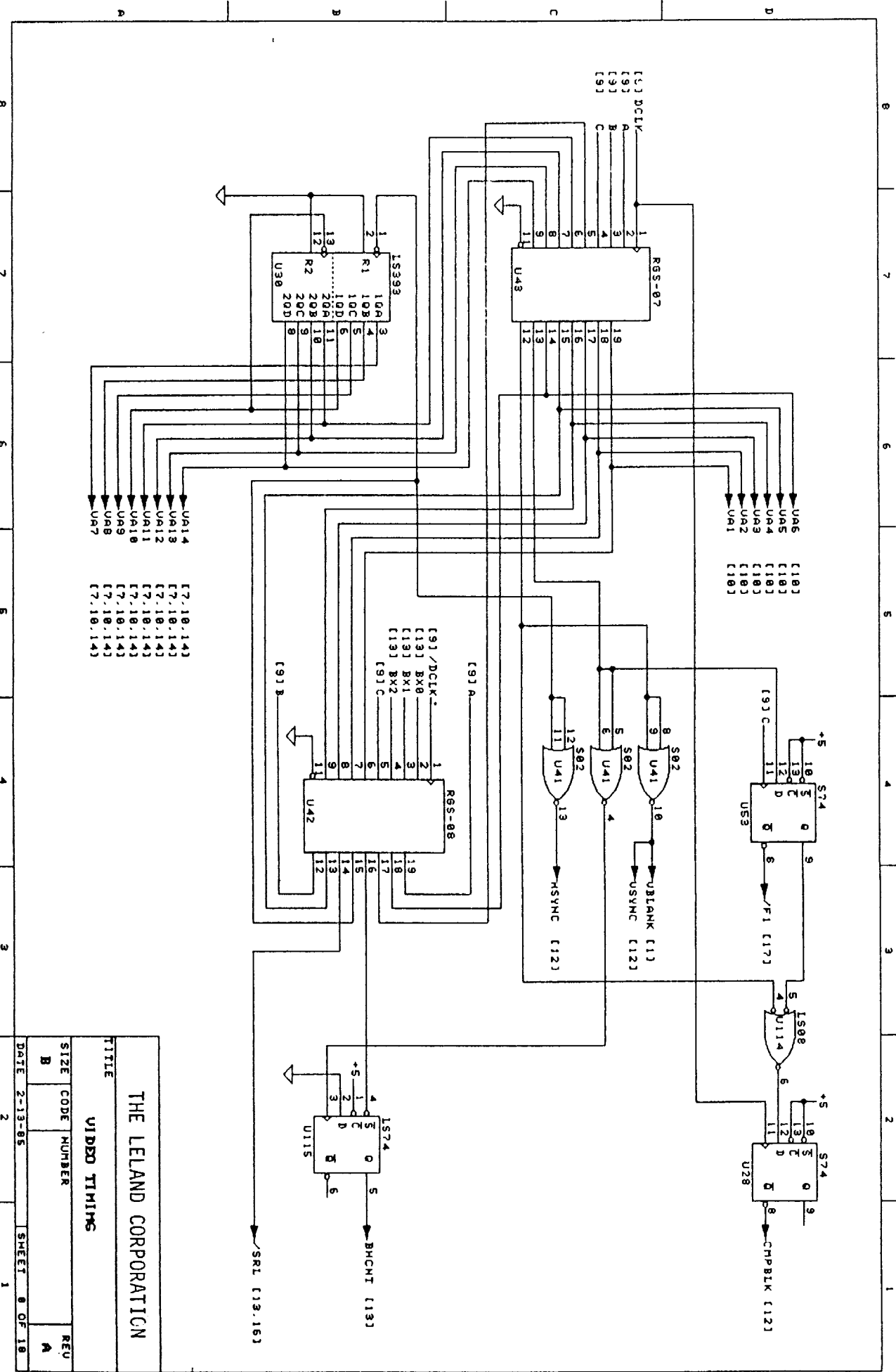

THE LELAND CORPORATION			
TITLE VIDDO TIMING			
SIZE	CODE	NUMBER	REV
B			A
DATE	2-13-85	SHEET	8 OF 18

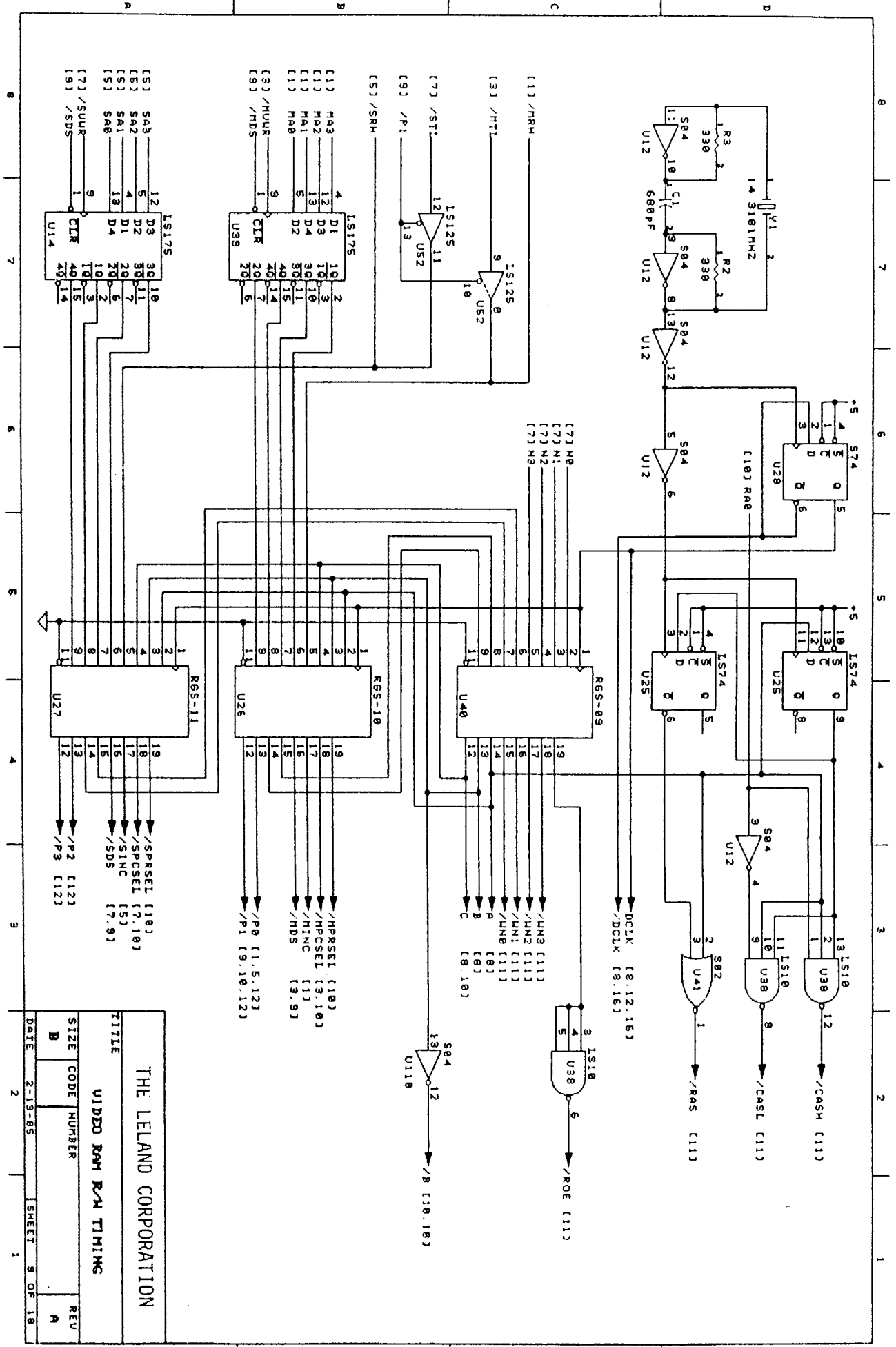

THE LELAND CORPORATION	
UIDDD RAM R/W TIMING	
SIZE CODE	NUMBER
B	
DATE	2-13-85
SHEET	9 OF 18
REV	A

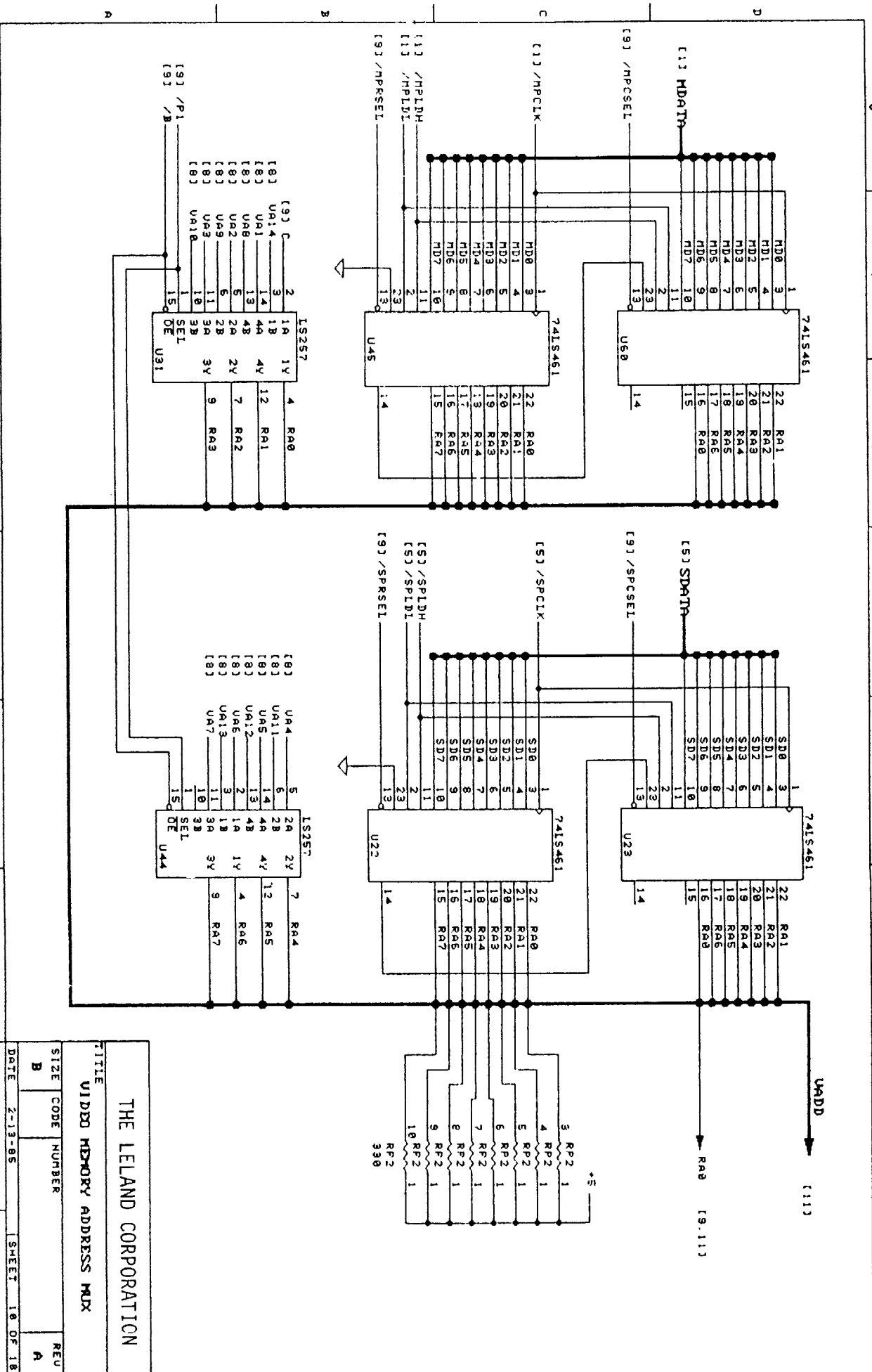

THE LELAND CORPORATION  
 VIDEO MEMORY ADDRESS MUX  
 TITLE  
 SIZE CODE NUMBER  
 B  
 DATE 2-13-85 SHEET 10 OF 18  
 REU A



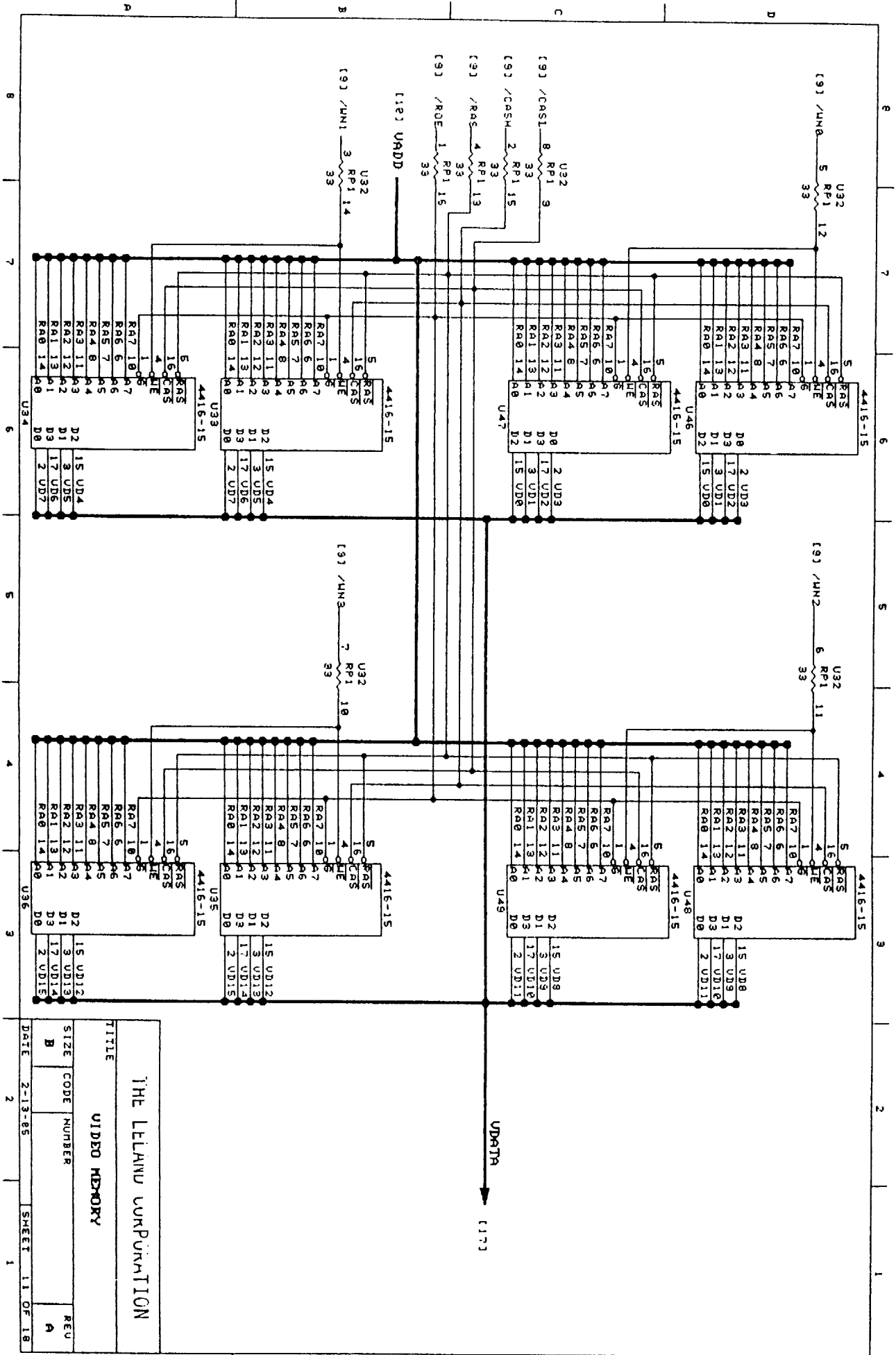

THE LELAND CORPORATION			
VIDEO MEMORY			
TITLE	CODE	NUMBER	REV
SIZE	B		A
DATE	2-13-85	SHEET	11 OF 18

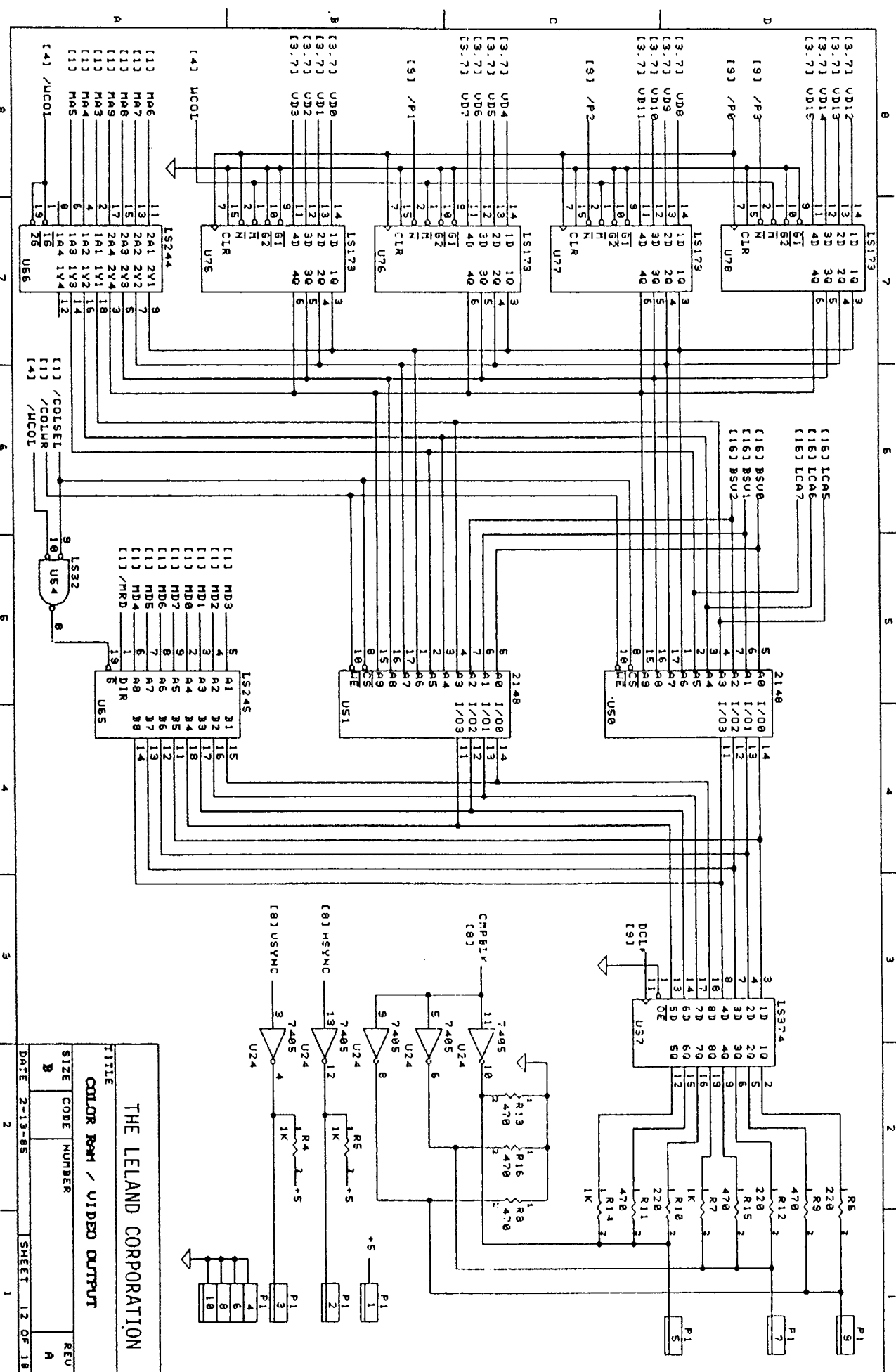

TITLE			THE LELAND CORPORATION		
COLOR B/W / VIDEO OUTPUT					
SIZE	CODE	NUMBER	REV		
B			A		
DATE 2-13-85			SHEET 12 OF 18		

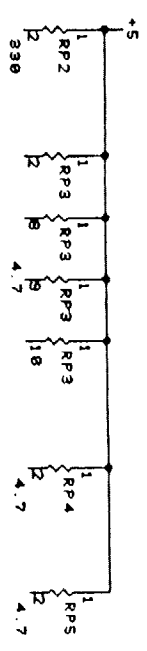
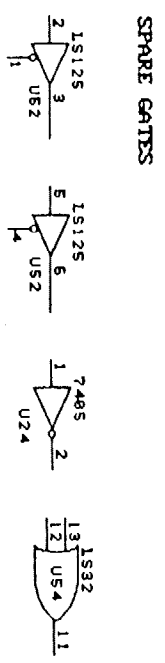
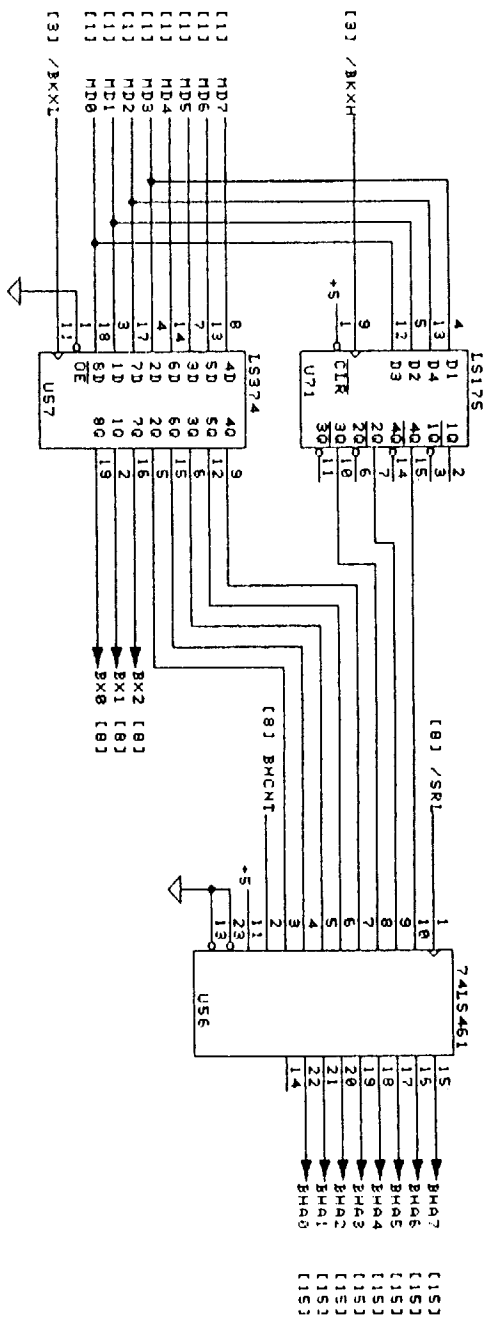

THE LELAND CORPORATION	
TITLE	
BACKGROUND HORIZONTAL ADDRESS	
SIZE	NUMBER
B	A
DATE	SHEET
2-13-85	13 OF 18

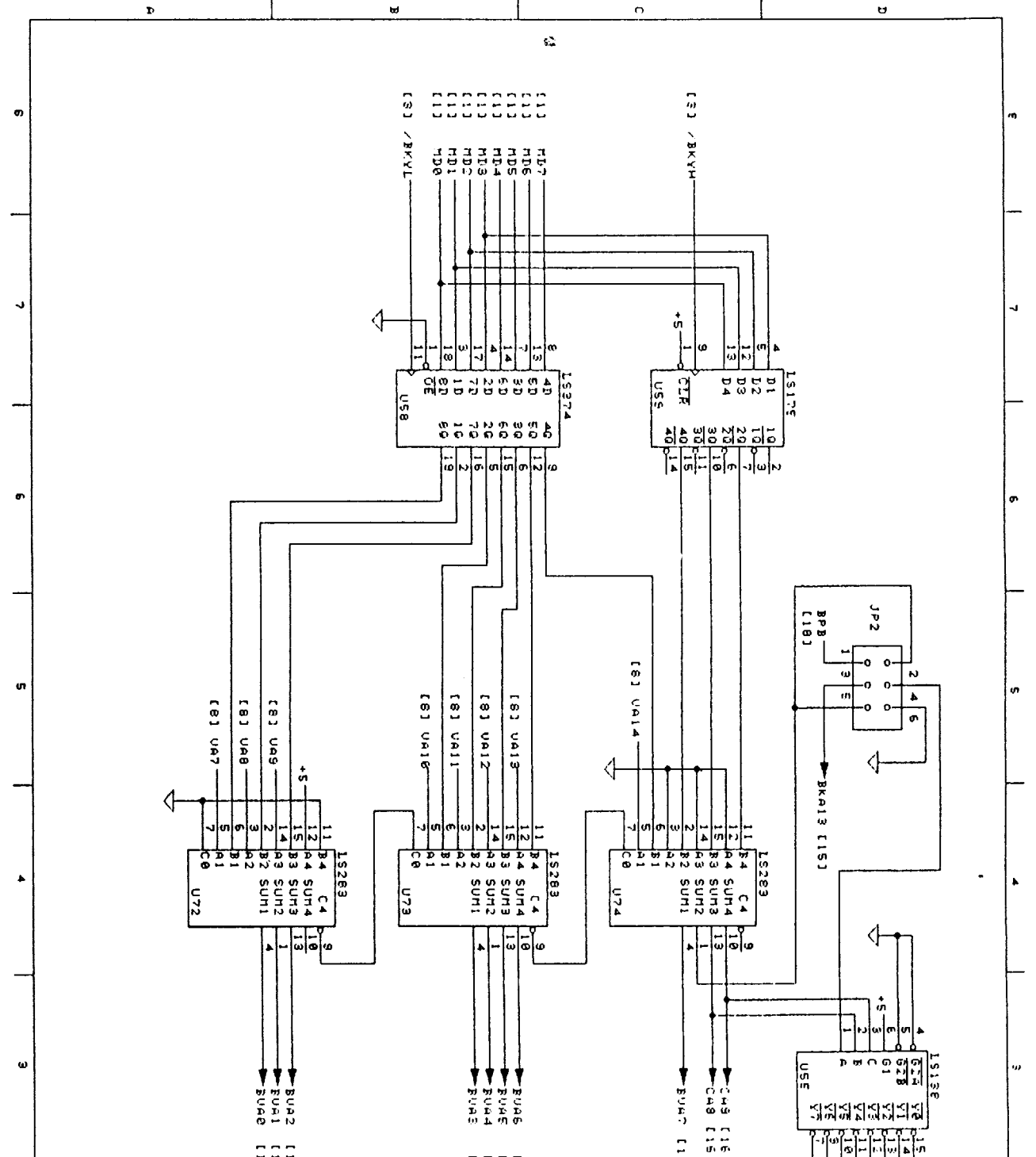

**THE LELAND CORPORATION**

**BACKGROUND VERTICAL ADDRESS**

TITLE		REV	
BACKGROUND VERTICAL ADDRESS		A	
SIZE	CODE	NUMBER	
B			
DATE 2-13-85		SHEET 14 OF 18	

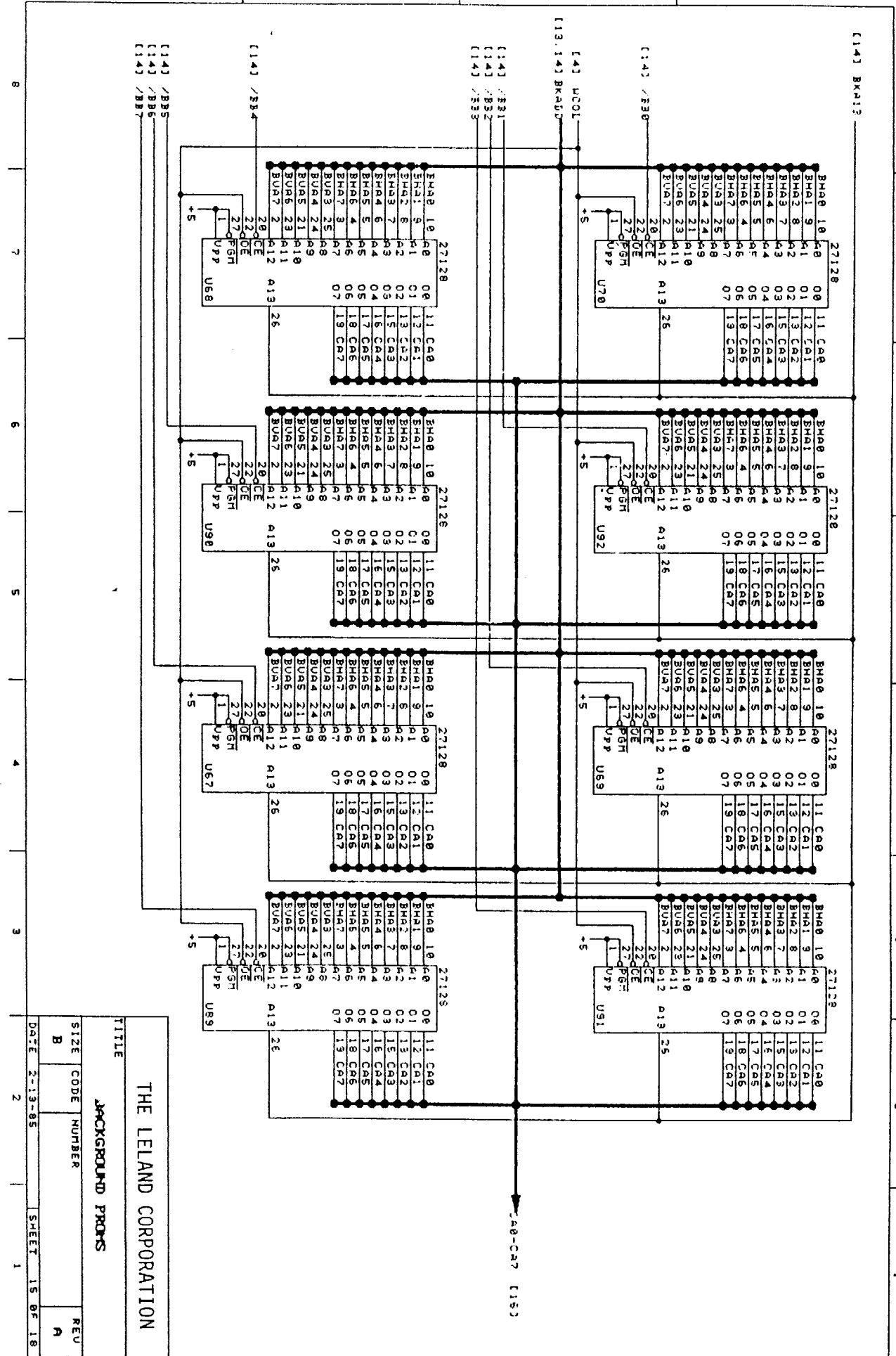

TITLE			
THE LELAND CORPORATION			
BACKGROUND PRODS			
SIZE	CODE	NUMBER	REV
B			A
DATE 2-13-85		SHEET 15 OF 18	

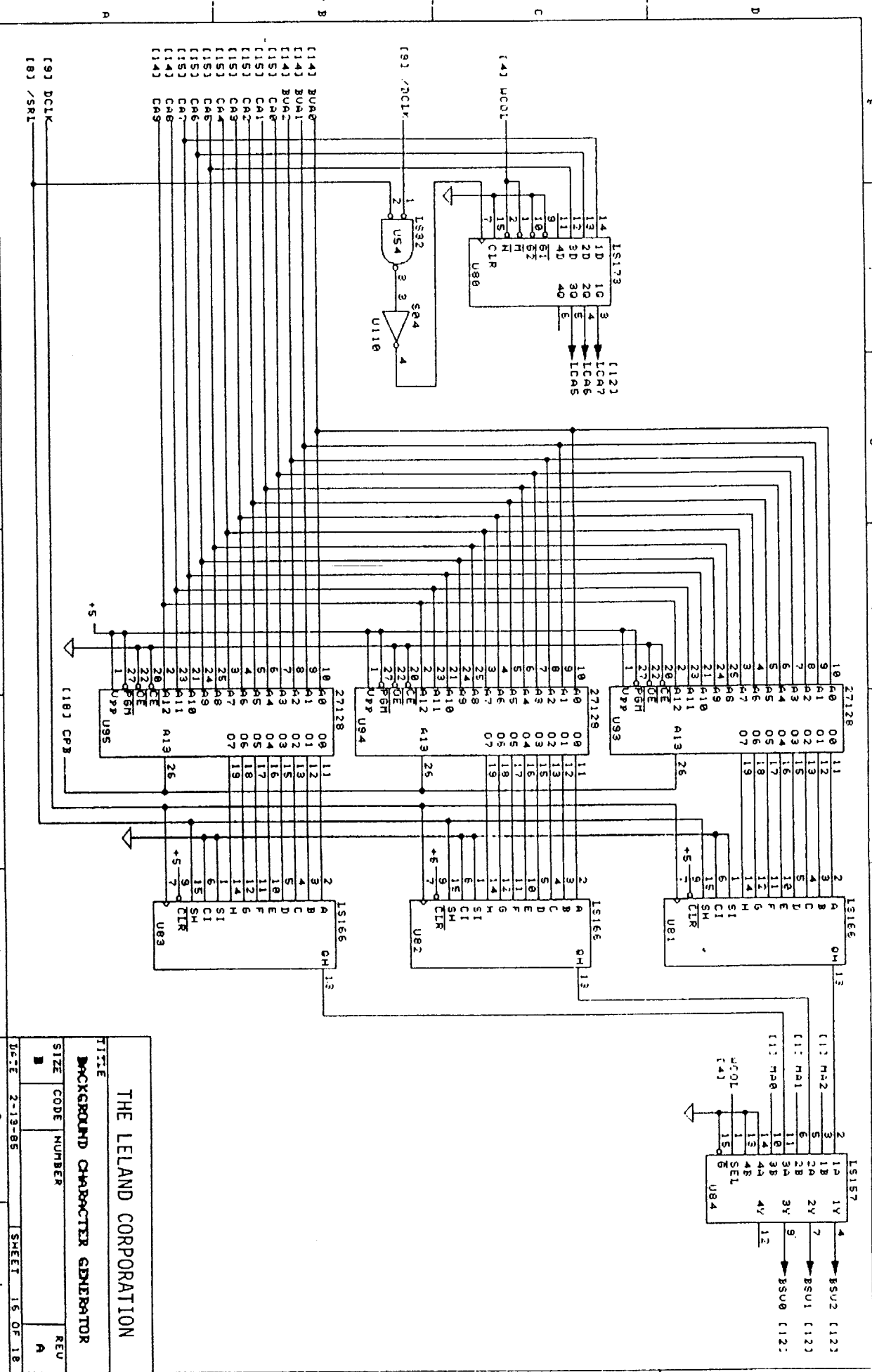

**THE LELAND CORPORATION**  
**BACKGROUND CHARACTER GENERATOR**  
 TITLE \_\_\_\_\_  
 SIZE CODE NUMBER \_\_\_\_\_  
 DATE 2-13-85 SHEET 15 OF 18

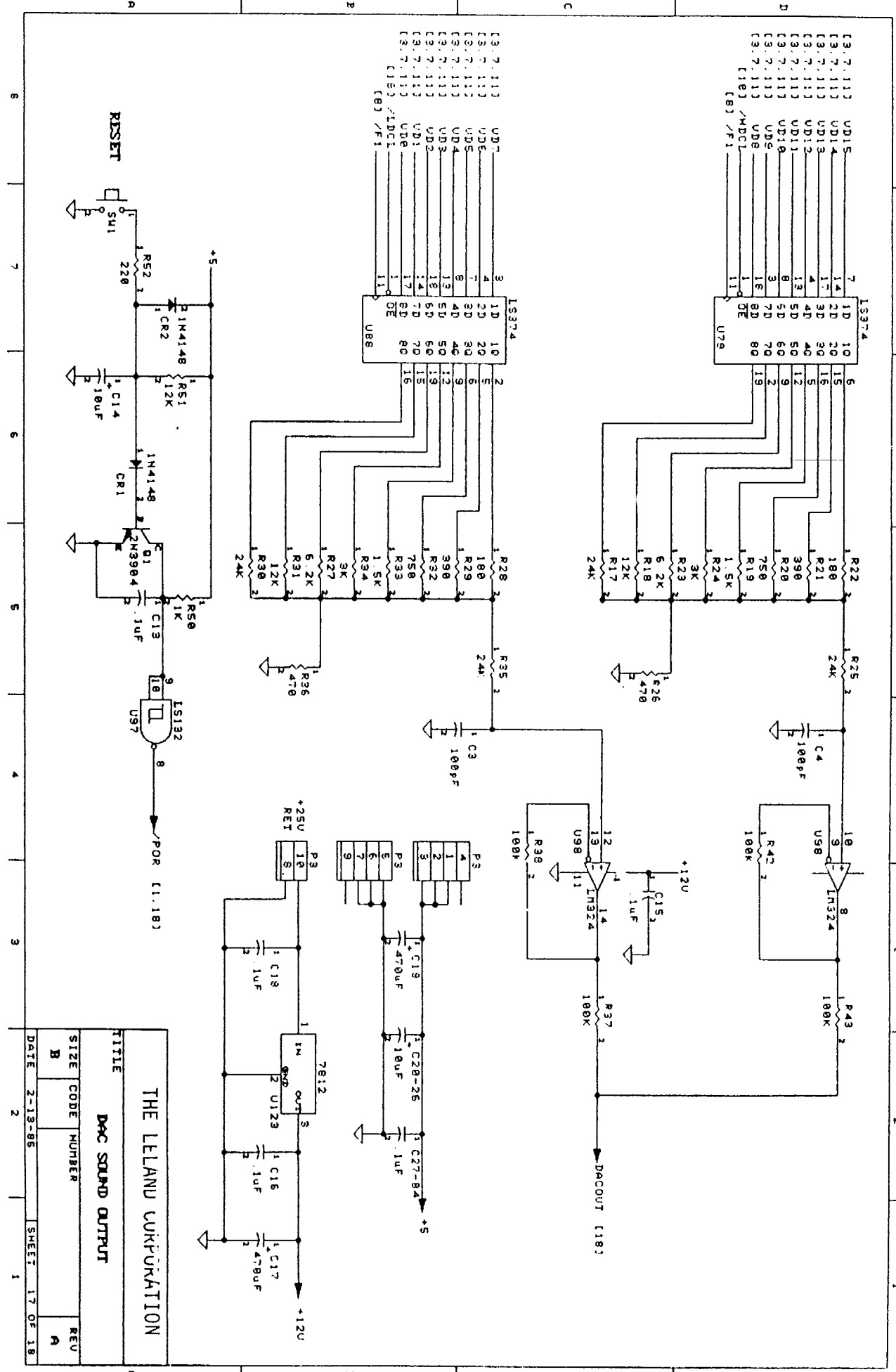

TITLE		THE LELAND CURPORKATION	
SIZE CODE		DAC SOUND OUTPUT	
DATE	2-13-95	SHEET	17 OF 18
REV	A		

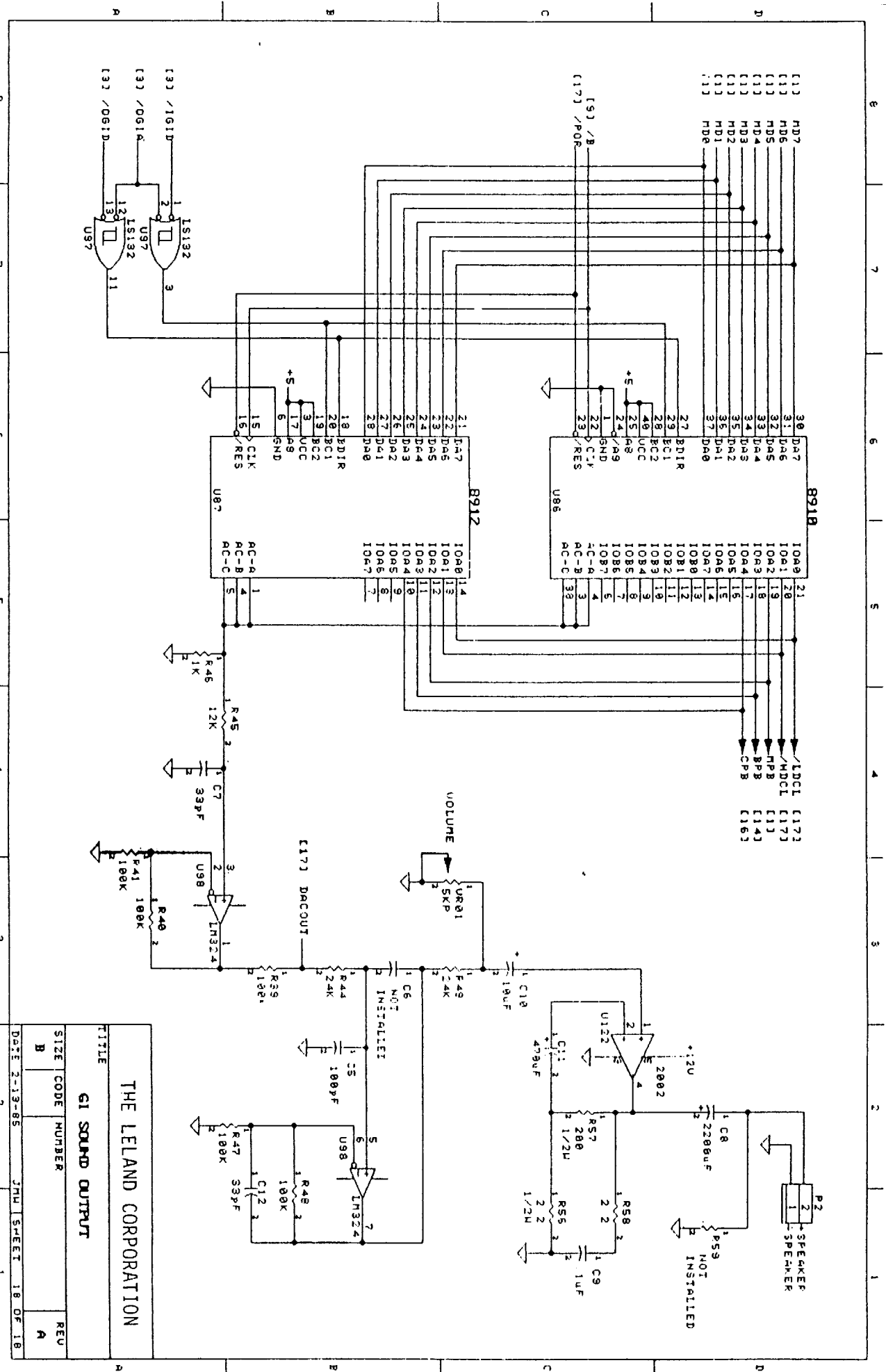

THE LELAND CORPORATION	
G1 SOUND OUTPUT	
TITLE	REV
SIZE	B
CODE	
NUMBER	A
DATE 2-13-85	JHW SHEET 18 OF 18



# K7000 COLOR MONITOR SCHEMATIC DIAGRAM

