

**HORIZONTAL CONVERSION KIT
INSTALLATION AND SERVICE MANUAL**

ARCADIA
Systems™

CONTENTS

Your Arcadia Game.....	3
Check List.....	4
Quick-Fit Instructions:	
1. Wiring Diagram.....	5
2. Playing Instructions.....	7
Installation.....	8
Wiring Harness.....	8
Control Panel.....	9
Graphics.....	9
Double Check.....	9
Configuration Options.....	10
Diagnostics.....	12
Difficulty Level.....	15
Statistics.....	16
Clear High Scores.....	16
Coinage.....	17
Attract Sequence Audio.....	17
Volume Adjustment; Stereo/Mono.....	18
Maximum Game Play Time.....	18
Free Play.....	19
Exit Configuration Menu.....	19
Diagrams.....	20
Warranty.....	24

LEADER BOARD GOLF
Installation and Service Manual

Developed by:

Arcadia Systems, Inc. tel (415) 949-5290
201 San Antonio Circle fax (415) 949-0157
Suite 263 tlx 9102409392 ARCADIA USA UQ
Mountain View, CA 94041

Manufactured by:

The Leland Corporation tel (619) 562-7000
1841 Friendship Drive fax (619) 562-9468
El Cajon, CA 92020 tlx 4974293 CINTRON

FCC WARNING

This equipment generates, uses, and can radiate radio frequency energy and if not installed and used in accordance with the instruction manual, may cause interference to radio communications.

It has been tested and found to comply with the limits for Class A computing device pursuant to Subpart J of Paragraph 15 of FCC Rules, which are designed to provide reasonable protection against such interference when operated in a commercial environment.

Operation of this equipment in a residential area is likely to cause interference in which case the user at his own expense will be required to take whatever measures may be required to correct the interference.

The FCC compliance label included in this kit must be clearly and legibly affixed to the outside of your game cabinet before you operate your machine.

YOUR ARCADIA GAME

Congratulations!

You have just bought your first video game conversion kit from Arcadia Systems. This exciting new game has been designed by Arcadia to provide you, the operator, with 1) easy installation, 2) many months of trouble-free operation, and 3) an excellent return on your investment.

A little extra time taken here can save you many headaches down the road, as faulty installation can harm your machine, and may void your warranty. Painting, filling, changing lights, control plexi, etc. on your game cabinet will increase the overall appeal of your game, and help you to maximize your collections over the long run.

Good luck!

QUICK-FIT INSTRUCTIONS

1. ADAPTER PRINTED CIRCUIT BOARD

CHECK LIST

Before you get started, check the Kit Contents list below, to insure that your kit is complete, and that there are no damaged or missing parts. You also need to verify that your Power Supply is adequate, and that your Monitor Configuration is correct. You will need some or all of the Tools and Supplies listed below to complete the installation.

KIT CONTENTS

- | | |
|-----------------------|-------------------------|
| 1 PCB Assembly | 1 Set Control labels |
| 1 Main Wiring Harness | 1 Set Side Decals |
| 1 Marquee Artwork | 1 Marquee Plexi |
| 2 4-Way Joysticks | 1 Control Panel Overlay |
| 6 Button Assemblies | 1 Control Plexi |
| 1 Set Connectors | 1 Installation Manual |
| 1 FCC Label | |

POWER REQUIREMENTS

You need a reliable power supply which meets the following minimum specifications:

- | | |
|--------------|----------|
| +5 Volts DC | @ 7 amp |
| -5 Volts DC | @ .1 amp |
| +12 Volts DC | @ 1 amp |

MONITOR REQUIREMENTS

Horizontal Mount Raster Scan with Negative Composite Sync.

TOOLS AND SUPPLIES

- | | |
|------------------------------------|-------------------------|
| LEADER BOARD Conversion Kit | Small file |
| Phillips and slot screwdrivers | Razor knife |
| Wire cutters and strippers | Straight edge |
| Pliers | Painting supplies |
| Electric Drill | Filler |
| Drill bits (3/32", 1/4" & 7/16") | Staple gun |
| 1/4" Plex hole saw | 60/40 Resin core solder |
| 1 1/4" Plex bit | Soldering iron |
| Shrink tubing (3/32", 1/8", 3/16") | Vacuum Cleaner |
| Wire ties (3 1/2" or 4") | Masking tape |
| Assorted fastening hardware | Window cleaner |

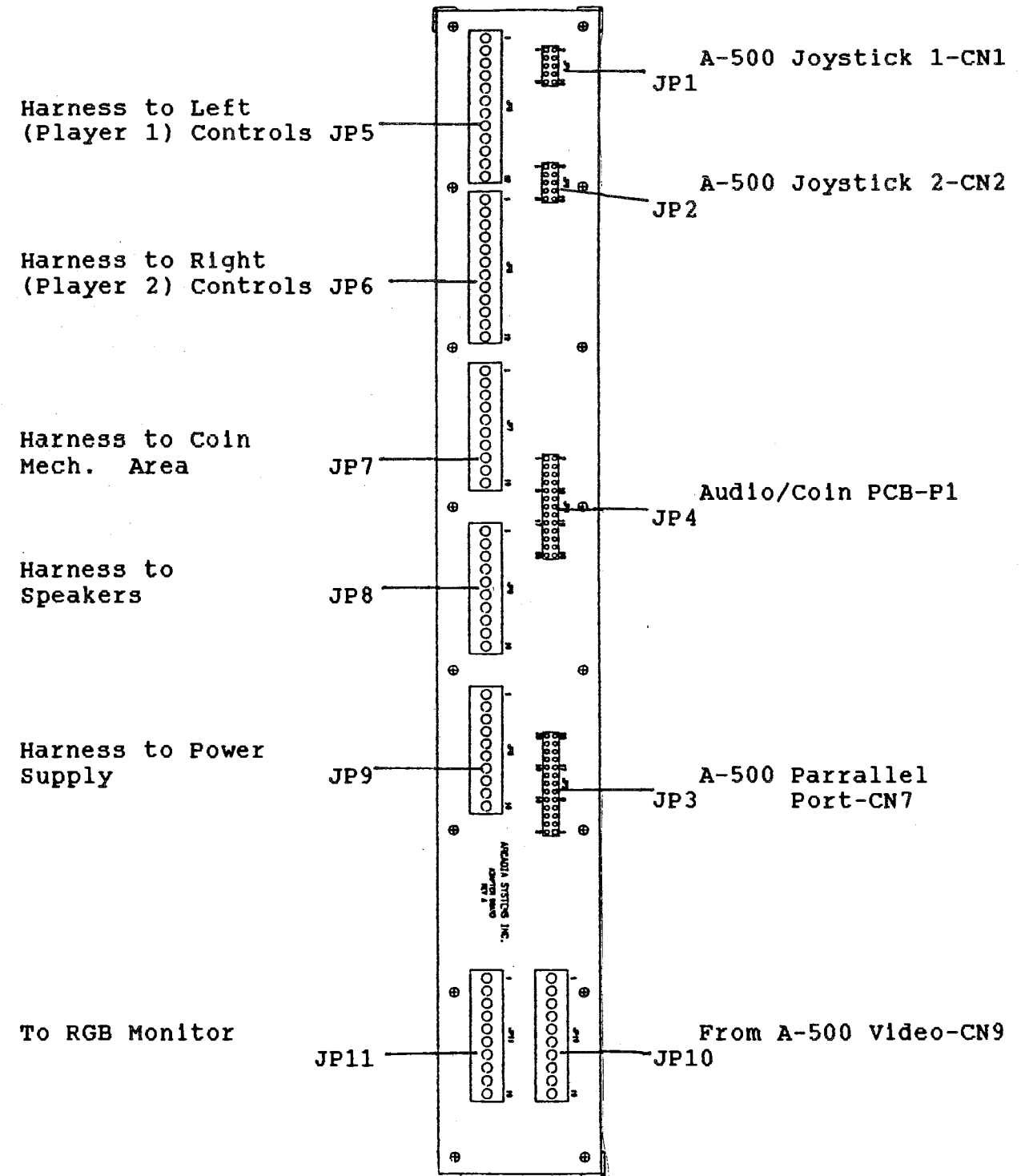

See following page for pin-out information.

PIN OUT/WIRING SPECIFICATIONS
FOR ADAPTER PRINTED CIRCUIT BOARD

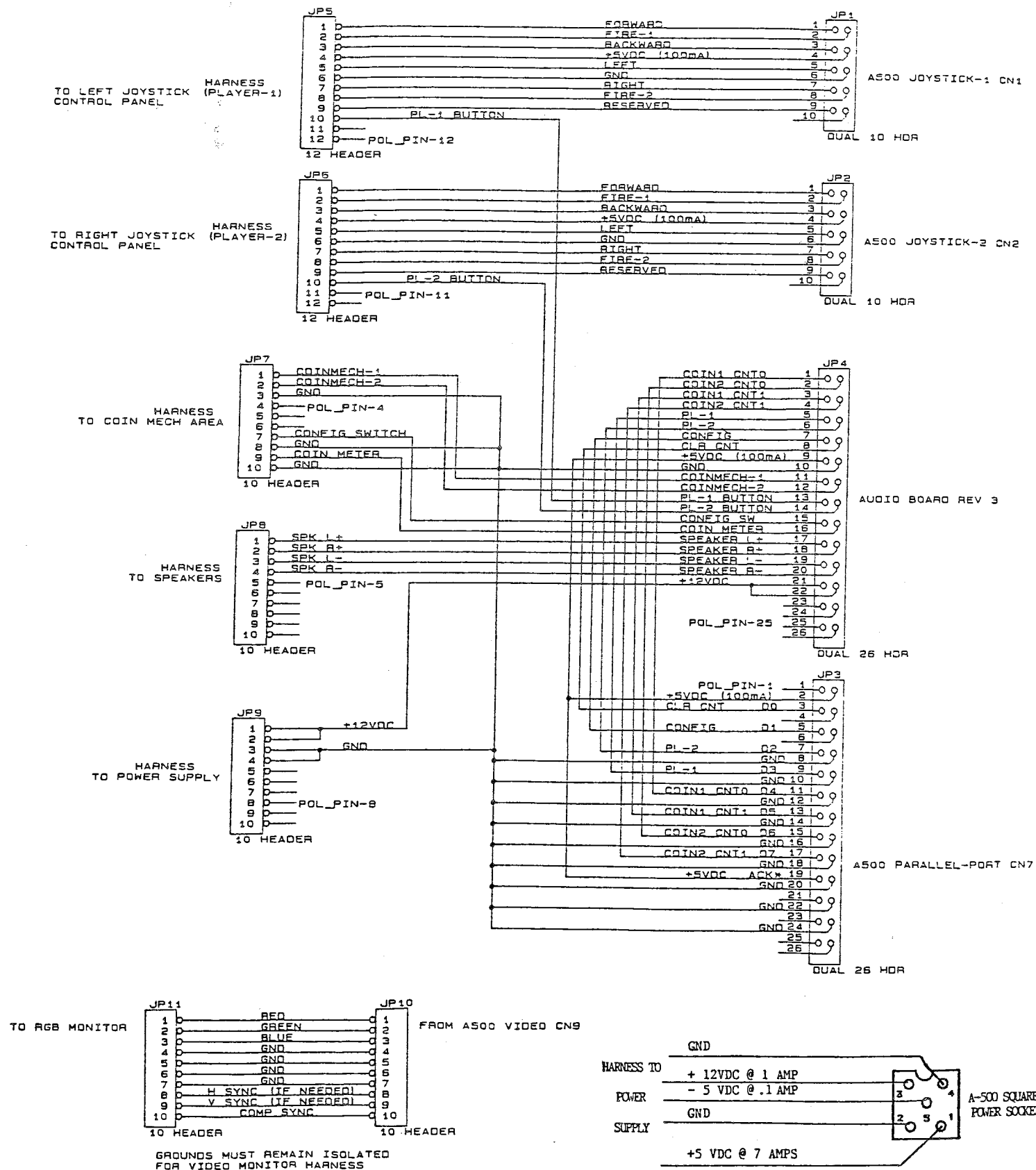

QUICK-FIT INSTRUCTIONS

2. PLAYING INSTRUCTIONS

The object of the game is to complete the course with the minimum number of shots. Leader Board is a 1 or 2 Player (alternating) horizontal game, incorporating many of the skills and challenges found in a real game of golf.

Fire 1 changes your club selection, if the suggested club is not to your liking. Fire 2 gives you an overhead view of the hole, and shows the minimum/maximum range of the currently-selected club.

To take your shot, move the cursor (right/left) with the joystick to aim, then move the joystick in a 1 - 2 - 3 sequence:

1. Pull the joystick back (down) to start your swing.
2. Release the self-centering joystick as the player reaches the top of his backswing. This sets the power of the shot at maximum. If you release too soon or too late, you get less than full power. Power is shown on the power meter at the lower right corner of the screen.
3. Push the joystick forward (up) just as the club hits the ball to get a straight shot. If you push forward before the club meets the ball, your shot will hook left; pushing up after the impact gives you a slice right. The Hook/Slice meter is located on-screen just under the Power Meter.

Hook and Slice can be used to counteract the effect of the wind, or to shoot around trees onto the green. If you are shooting out of a sand trap, you need as straight a shot as possible, as too much hook or slice will leave you in the trap.

On the green, you are shown the direction of downward slope, and the degree of steepness. You must aim up into the slope to counteract the break of the green. Hold the joystick down until the power is right, then release to shoot.

LEADER BOARD incorporates an EXTENDED PLAY feature, whereby the player is awarded extra time for skillful play. Completing a hole on par gives the player an extra 5 seconds; one under par gives you 20 extra seconds, two under gives 40 seconds, three under gives 80 seconds, and a hole-in-one awards an extra 120 seconds (See Maximum Game Play Time below).

INSTALLATION

To prepare your cabinet for installation of your LEADER BOARD kit, you must first remove the old game PC boards, Control Panel and Marquee. Remove any old side graphics, and insure that the cabinet sides are prepared to accept the new adhesive side graphics. Laquer thinner can be used to remove old adhesive residues.

Mark and drill pilot holes on the inner cabinet wall, and install the PC board in the cabinet by screwing through the pre-drilled holes in the mount plate.

WIRING HARNESS

Attach the six cabinet wiring harnesses to the Wiring Adapter board. Make sure that the number marked on each molex connector corresponds to the number on the adapter board, and that the polarizing pins are correctly aligned. The square 5-pin power connector must be fitted to the square socket on the A-500 Amiga board (see diagram), with the polarizing notch facing upwards. Both this harness and the molex power harness JP9 have to be connected directly to the power supply.

Connect the new harness wires to the existing cabinet wires, using the PIN-OUT WIRING SPECIFICATIONS chart on pages 5-6 of this manual. Cut and strip the old wires about three inches from the existing secondary connectors, cut and strip the new wire, solder them together, and melt shrink tubing around the splice. Tying bare wires and wrapping in electrical tape will not produce reliable connections, and can cause intermittent problems later on! Tie wraps and tie downs will help maintain easy access to your electronics by preventing accidental 'snags'.

NOTES:

1. The monitor harnesses provides a composite negative synch connection, which is used by most monitors. Separate horizontal and vertical synch wires are also provided, but would not normally be used.

2. The coin door wires can be fitted either to normally open or normally closed switches, but if you wish to connect a coin meter, then you must wire the coin mechs for normally closed.

3. If you are using only one speaker, make sure that neither speaker terminal is grounded through the speaker frame, then use pins 1 and 2 (R+ and L+) on the speaker harness JP8. You must also set the three jumpers on the Audio / Coin PC board for MONO (see diagram).

4. The joystick harness carries +5V DC, but this is not used for 4-way LEADER BOARD joysticks. Do not try to power the coin door lights using this lead; the coin door lights must be driven directly from the power supply.

CONTROL PANEL

After removing the control panel, remove the buttons, joysticks and wiring harness. Then mark and drill new holes on the panel for buttons, joysticks and retaining bolts (a sheet metal punch works best for button holes).

Cut your control panel plexi to size by scoring deeply with a razor knife, and snapping off the excess. Drill holes in the plexi to correspond with the holes in your control panel, and smooth the edges of the drill holes.

Remove the old graphics overlay from the control panel, clean the panel, and attach the new LEADER BOARD overlay, leaving enough excess to wrap around the top edge. Trim the excess overlay material, then attach the button and joystick labels. You can now place the plexi over the control panel, and mount your new joysticks and buttons.

Connect the wiring harness to the controls, and re-fit the control panel to the machine.

GRAPHICS

Remove the old marquee, and cut the new marquee plexi to the same size. Attach the new LEADER BOARD lexan artwork to the marquee plexi, trim the excess, and fit it to the machine.

Clean the sides of the cabinet and apply the new side decals.

Remove the monitor plexi and attach the Game Instruction Card to the monitor bezel.

DOUBLE CHECK

Inspect the game to make sure that there are no exposed wires, loose screws, obstructions to the PC board, etc.

Check the connections once again for the wiring harness, to make sure you have not misplaced any wires. This is worth doing carefully, while referring to your pin-out chart, since anyone can make a simple mistake here, but the effects can be devastating!

Turn on the power to the machine, and listen for clicks, pops, hums, arcing sounds, etc. Check to see if any burning smells suddenly appear. You should get a picture within a few seconds, which shows the game initialization routine. Tap the fire button twice, and you will see the first demo screen.

Volume and monitor adjustments are covered in the following section.

CONFIGURATION OPTIONS

Your LEADER BOARD GOLF kit has been designed to utilize a simple, easy-to-use Configuration program, whose features can be quickly mastered by experienced and inexperienced operators alike.

Several convenient Operator-adjustable functions are handled through the Configuration Menu. Operators can alter the game difficulty levels, coinage options, volume, etc., as well as view and clear the game play statistics and run the hardware diagnostics by using the joysticks and Fire button controls at the front of the machine. This feature is intended to improve accessibility over the usual dip switches and volume potentiometer on many other manufacturers' PC boards.

The basic procedure for altering the configuration of your system is simply to move the red highlighted bar to the line item you wish to examine or alter, and press the Fire button. Changes can be erased or saved when you exit from the Configuration Menu.

Your machine has been programmed with several standard factory 'default' settings. The following pages describe the Configuration features, and explain how you can alter their default settings in order to customize or 'fine-tune' your machine to your particular location.

Also, included are a number of hints (paragraphs marked **), which should be particularly useful for new operators.

To enter the Configuration Menu, press the Configuration (or 'test') switch, and you will see the Menu appear. You can move through the Configuration Menu by pushing the joystick up or down to highlight a particular line item (or, on the Coin Counter lines, right or left), and you can change the values on individual lines, either quickly or slowly, by pressing the Fire buttons as directed. The Configuration Menu screen is shown on the following page.

CONFIGURATION MENU

Enter Hardware Diagnostic Menu
Difficulty Level (1 - 5): [3]
Clear game play Statistics:(Yes, No) [No]
Clear All games high Scores:(Yes, No) [No]
Left Coin Counter: [1] Coins equals [1] Plays
Right Coin Counter: [1] Coins equals [1] Plays
Attract Sequence Audio:(On, Off) [On]
Game/Demo Volume (0 - 4) [3]
Max Game Play Time (0:00 - 15:00) [2:30]
Free Play Continuous: (Yes, No) [No]
Exit without Saving Changes
Exit and Save Changes

Total Game Play Time: 0:00:00
Total Credits: 0
Average Time/Credit: 0

****Use Either Joystick to move Cursor****
****Use Fire 2 Buttons to select/change option slowly****
****Use Fire 1 Buttons to select/change option fast****

THE HARDWARE DIAGNOSTICS MENU

Move the joystick up or down as necessary to highlight the "Enter Hardware Diagnostics Menu" line and press the Fire button. You will then see the following screen:

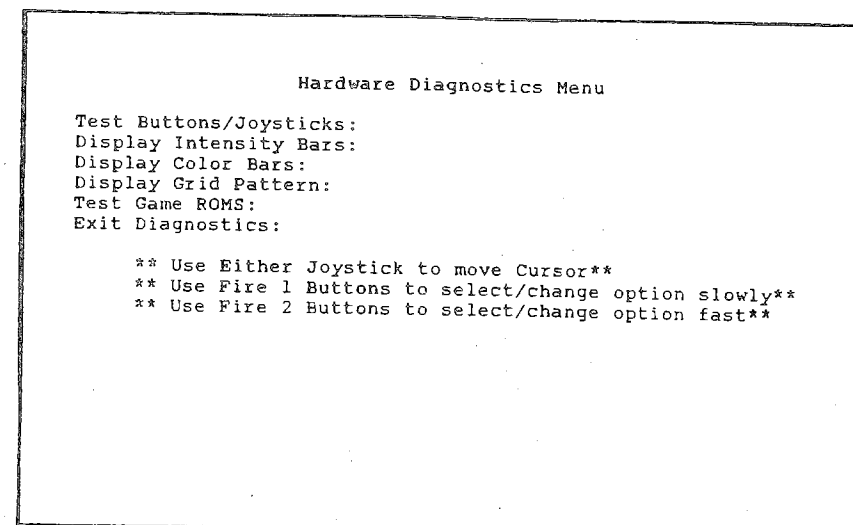

Move the joystick to the line desired, and press Fire.

A. Test Buttons/Joysticks

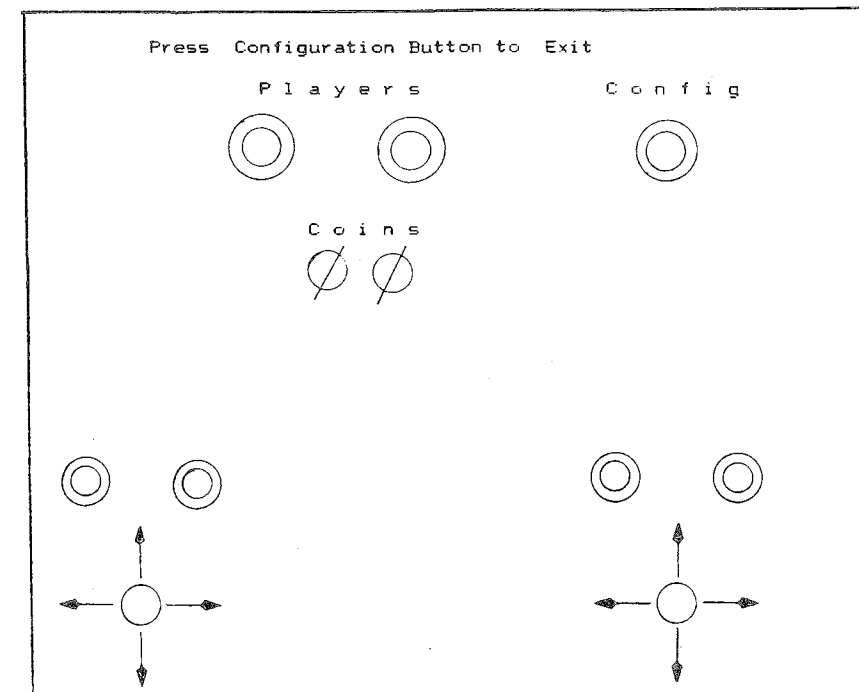

This screen enables you to see if your Fire buttons, Player buttons, coin mechanisms, joysticks and configuration button are all working correctly. Each control flashes green when activated (except the coin mechanisms, which register coin drops). Intermittent or "sticky" buttons can be identified, and joysticks can be fine-tuned for good response, and to alleviate joystick "bounce".

**The wiring lugs connected to the leaf switch terminals can sometimes work loose, preventing proper contact from being made. A loose ground wire on one switch can also disrupt other controls. Note that if you use leaf-spring joysticks instead of the microswitch joysticks supplied with your kit, these can sometimes become slightly stretched or bent, making them either too sensitive, or not sensitive enough to control movements. Bending the steel support tab next to the leaf spring is normally sufficient to adjust joystick responsiveness.

**Joystick "bounce" occurs when the joystick is released from, for example, the "Move Right" position, and jumps back to make contact briefly with the "Move Left" position before coming to rest at the central position. This can be very annoying to players who wish to precisely position their on-screen characters, and can be remedied, on leaf-switch joysticks, by bending the leaf support tabs slightly away from the joystick shaft.

Press the Configuration switch to return to the Hardware Diagnostics Menu.

B. Display Intensity Bars.

The next three menu selections are useful to adjust the settings of your monitor. For this you need to find the location of the adjustment knobs for brightness, contrast, focus, horizontal and vertical hold, etc. on your monitor.

The Intensity Bars give a good reference screen to adjust brightness and contrast. Select this item from the Hardware Diagnostics Menu by moving the joystick and press Fire. Adjust the settings as needed and press Fire again to return to the Hardware Diagnostics Menu.

C. Display Color Bars.

Proceed as with Intensity Bars, for adjustment of color saturation and hue. Press Fire to exit.

D. Display Grid Pattern.

The grid pattern is used to align the horizontal and vertical position of the display, and to adjust the overall size of the image. Optimally, the grid should be centered about 1/2 inch inside the picture tube borders. Press Fire to exit.

INTENSITY BARS

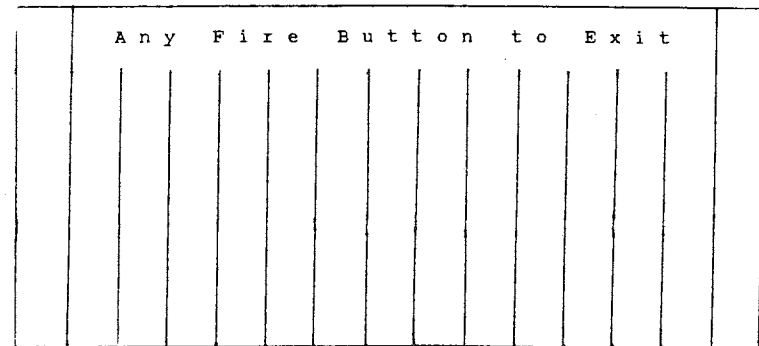

COLOR BARS

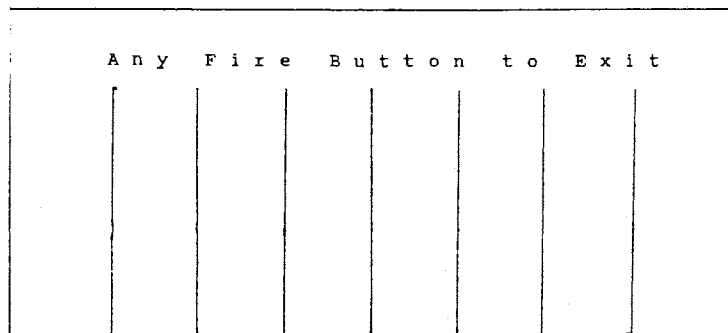

GRID PATTERN

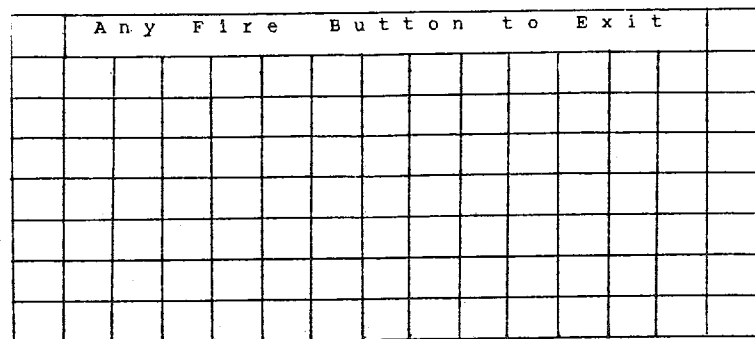

E. Test Game ROMS.

Select this item and press Fire to check the status of the PIGGYBACK ROM BOARD. The system software will verify the data contained in the game program chips, and report the status of the ROM board. Non-functioning ROM boards will be reported as "Failed: Check Sum Error". Working ROM boards will be reported as "OK".

In the event of an error message, switch off the power, wait a few seconds, and check to see if the Extender Board which joins the PIGGYBACK ROM BOARD to the MAIN PCB ASSEMBLY is securely seated. If necessary, pull off and re-seat the Extender Board, make sure it is clear of any obstructions, then switch the power back on. **DO NOT TOUCH THE PC BOARDS OR ANY OTHER ELECTRIC COMPONENT WITHOUT FIRST SWITCHING OFF THE POWER!** This test procedure will have taken you out of the Configuration Menu, into the normal start-up sequence. To continue the System Configuration, you will have to re-press the Configuration Menu switch, as described above.

Move the joystick to select Exit Diagnostics, and press Fire to return to the Main Configuration Menu.

DIFFICULTY LEVEL

The on-screen statistics give you detailed information on the game's performance, and help you to adjust the difficulty level of your game in order to achieve optimum performance in your particular location. The difficulty setting affects the wind velocity, the sensitivity of the Hook/slice meter, and the slope of the green.

To change the Difficulty Level, move the joystick down to highlight the Difficulty Level line, and press the Fire Button to change the value from 1 (easiest) to 5 (hardest).

Note that LEADER BOARD is played for a fixed amount of time, regardless of the difficulty level setting. The game can be set at varying difficulty levels to change the quality of game play, and this will affect the average playing time for the game, by making it easier for the player to win Extended Play. For each hole which the player completes with a par score, 5 seconds are added to his remaining time. 1 under par adds 20 seconds, 2 under par adds 40 seconds, 3 under par adds 80 seconds, and a hole-in-1 adds 120 seconds.

When you have finished altering the difficulty level, leave the value you have selected in place, and move the joystick down to select the next Menu item.

COINAGE OPTIONS

STATISTICS

At the bottom of the Configuration Menu screen, you are given the Total Game Play Time (hours, minutes, seconds), the Total Credits, and the Average Time per Credit. This information is retained, on a cumulative basis, until you clear the statistics. Powering down the machine does not affect the memory.

If you check your Game Play Statistics on a weekly basis, you can erase the current statistics by moving to the Clear Game Play Statistics line, and pressing the Fire button to change the value to Yes. Leave this new setting in place, and move to the next line with the joystick (see Exiting the Configuration Menu below). Leave this line set at No if you do not wish to clear the Game Play Statistics. Each time you re-enter the Configuration Menu, this value resets itself to the default value 'No'.

CLEAR HIGH SCORES

LEADER BOARD incorporates three High Score Tables, where top players can enter their initials opposite their best scores. The machine retains these scores in memory until they are surpassed by other players, and displays the High Score Tables periodically, during the Demonstration Mode, when the machine is not being played, at the end of the game, and when a player qualifies for the High Score Table.

The High Score tables are for the best scores on the Front Nine holes, the Back Nine holes, and for the best 18-hole games.

These scores can be cleared from the machine by pressing the Fire button to select Yes. Leave this value in place, and move to the next line. Leave the value set at No if you wish to retain the High Scores. Each time you re-enter the Configuration Menu, this value resets itself to the default value 'No'.

**Some players like to write offensive or obscene words in place of their names. These can be erased by using the Clear High Scores function. Also, periodically clearing the High Scores will give less experienced players an opportunity to appear in the High Score table.

LEADER BOARD can address two independent mechanical coin mechanisms, allowing the number of coins and the number of plays to be adjusted separately for each coin mechanism. Each value can be set between one and ten, to determine how many coins will be required for an individual game, and to award extra games for large-denomination coins.

For example, if one mechanism is set at one quarter or token per play, the other mechanism can allow 5 plays for a one-dollar coin, or three plays for two quarters.

To change the settings, move to the Left Coin Counter line of the Configuration Menu, and the 'Coin' box will be highlighted. Press the Fire button and you will see the value change to 2,3,4,...10, and then back to 1. Move the joystick to the right, in order to highlight the 'Plays' box, and press Fire to cycle through the numbers. You may select any number of coins, between 1 and 10, for any number of plays between 1 and 10 : 1 coin / 2 plays, 6 coins / 1 play, 8 coins / 7 plays, etc. The Right Coin mechanism can be separately adjusted in a similar fashion.

If you wish to use one coin slot for small denomination coins, and the other for large denomination coins, the illuminated coin slot should be marked with the appropriate label, and you will need to verify that the coin chute adjuster is set to accept coins of a particular diameter.

When you have finished selecting the coin options, leave the desired values in the 'Coins' and 'Plays' boxes, and move to the next menu item.

ATTRACTION SEQUENCE AUDIO

While the machine is not being played, it, repeatedly cycles through the "Attract" or Demonstration Mode. This shows the LEADER BOARD title screen, a brief self-playing demonstration of the game, and the High Score table. The repetitive sound effects and music can become tedious for anyone who spends many hours working in the vicinity of the machine, and thus an option has been included to silence the machine while it is not actually being played.

To switch off the Demonstration Audio, move the joystick to highlight the Attraction Sequence Audio line, and press Fire to select Off. Leave this value in place, and move the joystick to select another menu item. This value will not reset until you manually change it. If you wish to keep the Attract Sequence Audio, leave the value set at On.

VOLUME ADJUSTMENT / STEREO - MONO

You can adjust the volume of the machine by using the joystick to select the Game/Demo Volume line, and pressing the Fire button to change the value. Each game normally has five volume steps (including the 'off' position, which is step 0), and you will therefore need to increase or decrease the value by one point in order to move to the next volume step.

If the range of volume adjustments is still altogether too loud or altogether too soft, you will need to adjust the two (stereo) volume pots on the Audio/Coin PC Board, which is included in the main PC Board Assembly (see diagram).

The normal recommended setting procedure is as follows:

1. Set the Configuration Menu value to 4.
2. Rotate the volume pots on the Audio/Coin PC Board until the two sound channels are balanced, and the music is the loudest you would ever like to hear in your location.
3. Select normal operating volume (i.e. level 1,2, or 3), and proceed to the next menu item.

The Audio/Coin PC board in the Main PCB assembly can be set for MONO or STEREO operation. If you are installing LEADER BOARD in a cabinet which has only one speaker, or if you wish to wire your two speakers together, you will need to move the three jumper plugs to the MONO position (see diagram).

MAXIMUM GAME PLAY TIME

The fixed time limit for LEADER BOARD can be adjusted, in increments of 10 seconds, between 10 seconds and 15 minutes, by selecting Max Game Play Time from the menu, and pressing the Fire Buttons to set the desired time. Two minutes thirty seconds is the standard factory setting.

FREE PLAY CONTINUOUS

A Free Play option is provided, and can be activated by selecting the Free Play Continuous line, and pressing the Fire button to change the value to Yes. This value will not reset until you manually change it.

Free Play is not used for normal commercial game operation, but can be useful for demonstration purposes, or for private use.

EXITING THE CONFIGURATION MENU

Move the joystick to "Exit Without Saving Changes" or to "Exit and Save Changes", and press Fire to return to Game Play/Demonstration Mode.

You would normally select Exit and Save Changes, unless you have made many confusing changes, lost track of where you were, and decided to start over again. Exit Without Saving Changes undoes everything you have changed since entering the Configuration Menu.

Move the joystick to the line desired, and press Fire.

MAIN PRINTED CIRCUIT BOARD ASSEMBLY

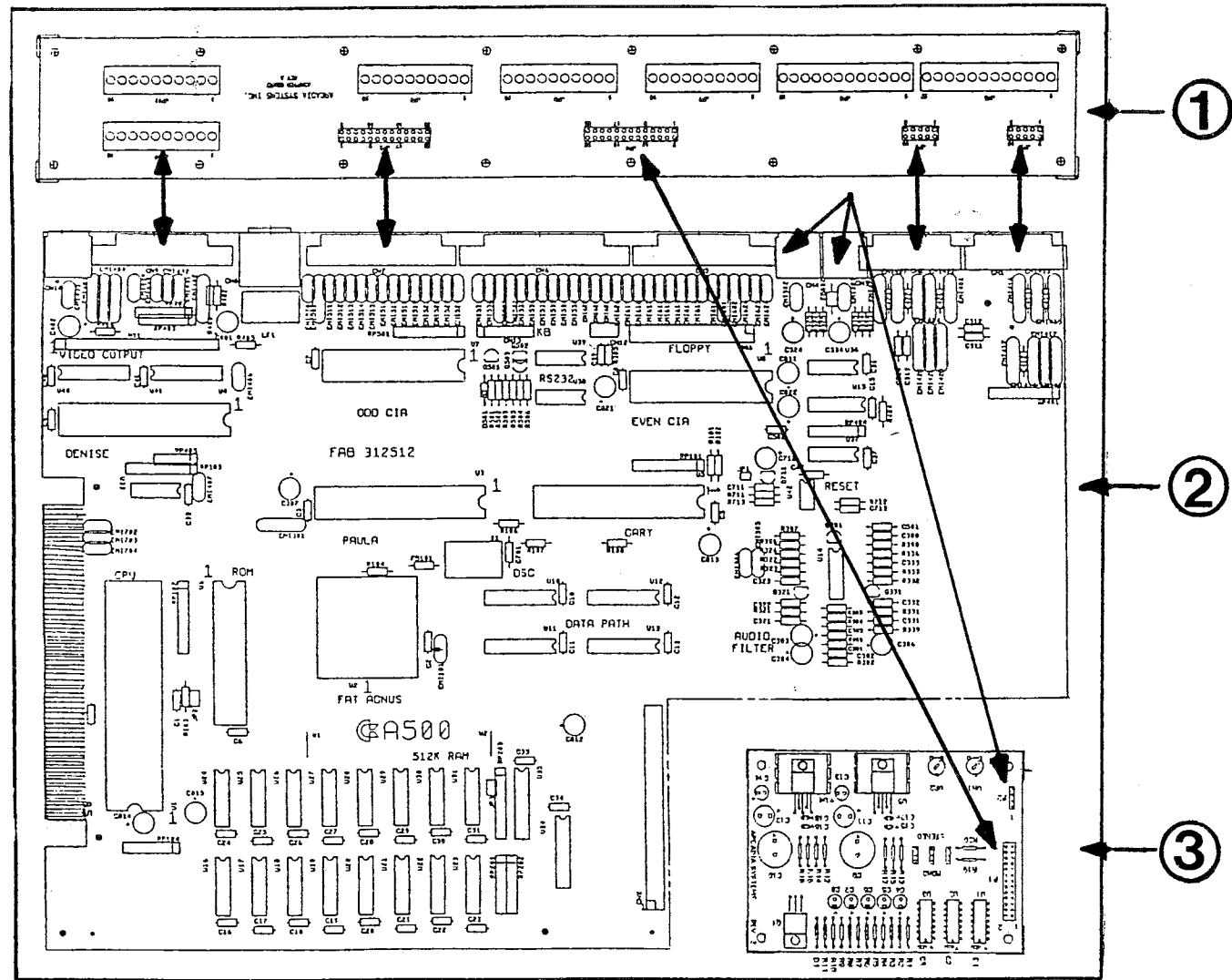

1. Adapter Printed Circuit Board
 2. A-500 Amiga Printed Circuit Board
 3. Audio/Coin Printed Circuit Board
- Arrows indicate wiring harness connections

A-500 AMIGA PRINTED CIRCUIT BOARD

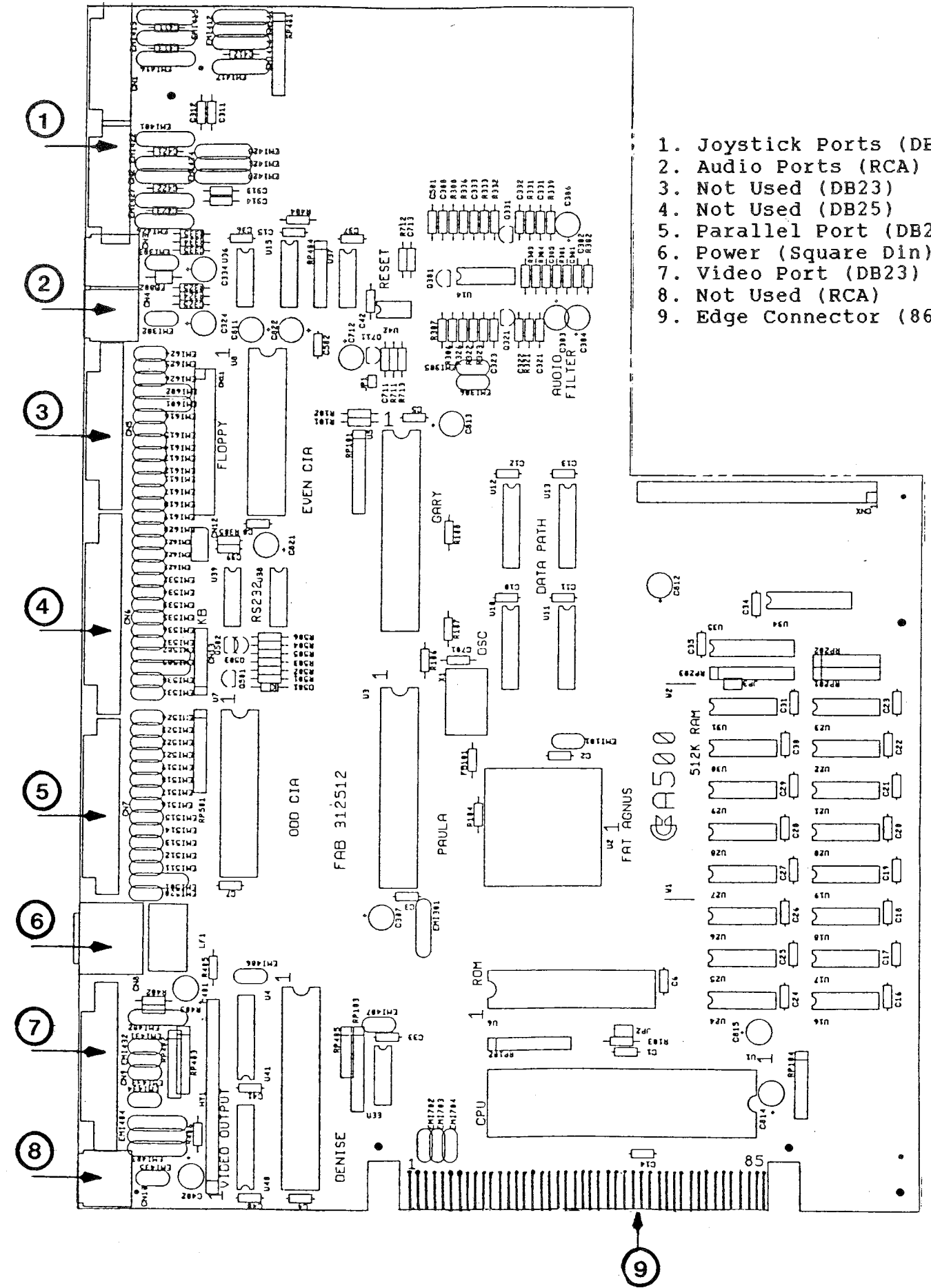

1. Joystick Ports (DB9)
2. Audio Ports (RCA)
3. Not Used (DB23)
4. Not Used (DB25)
5. Parallel Port (DB25)
6. Power (Square Din)
7. Video Port (DB23)
8. Not Used (RCA)
9. Edge Connector (86 Pin)

AUDIO/COIN PRINTED CIRCUIT BOARD

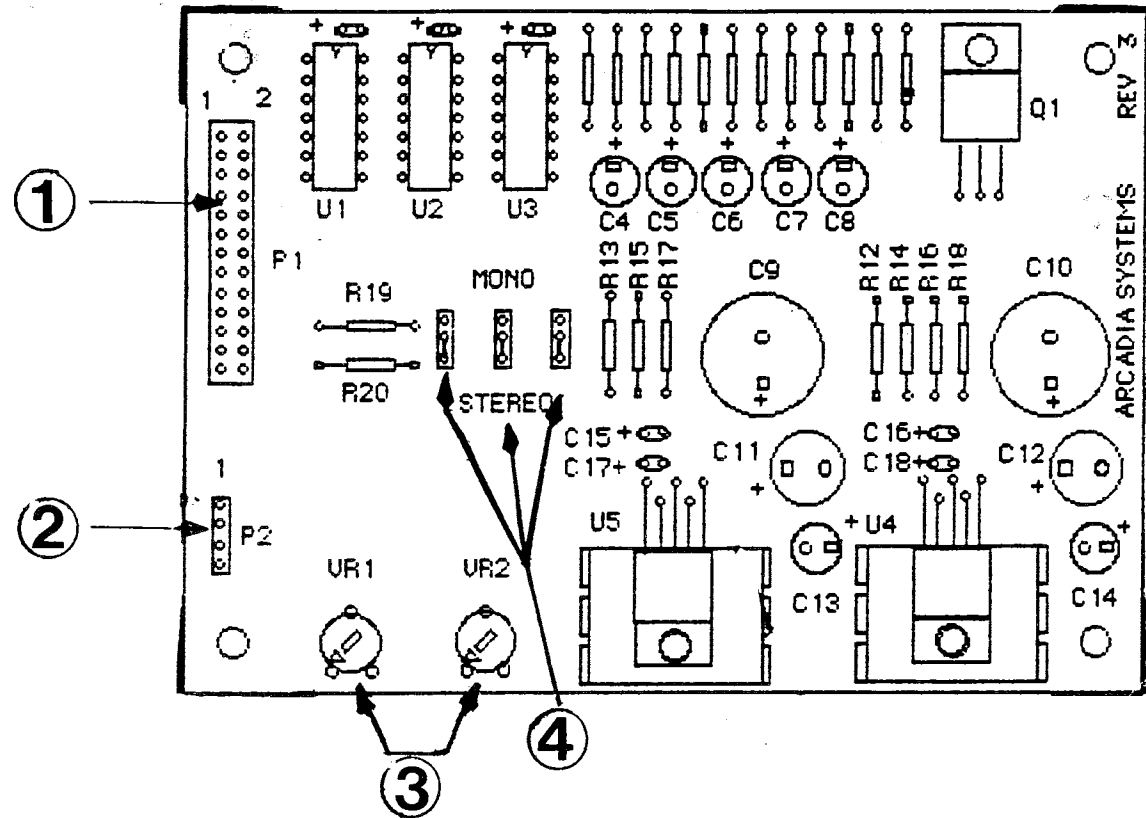

1. 26-position dual row header/connects to Adapter PCB at JP4.
2. 4-pin single row header/connects to A-500 audio jacks(RCA).

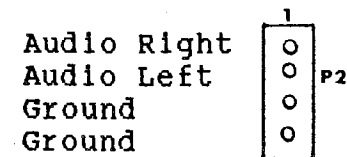

3. Volume potentiometer pots.
4. Stereo/Mono jumpers(x3). Normally set for stereo; move all three for mono.

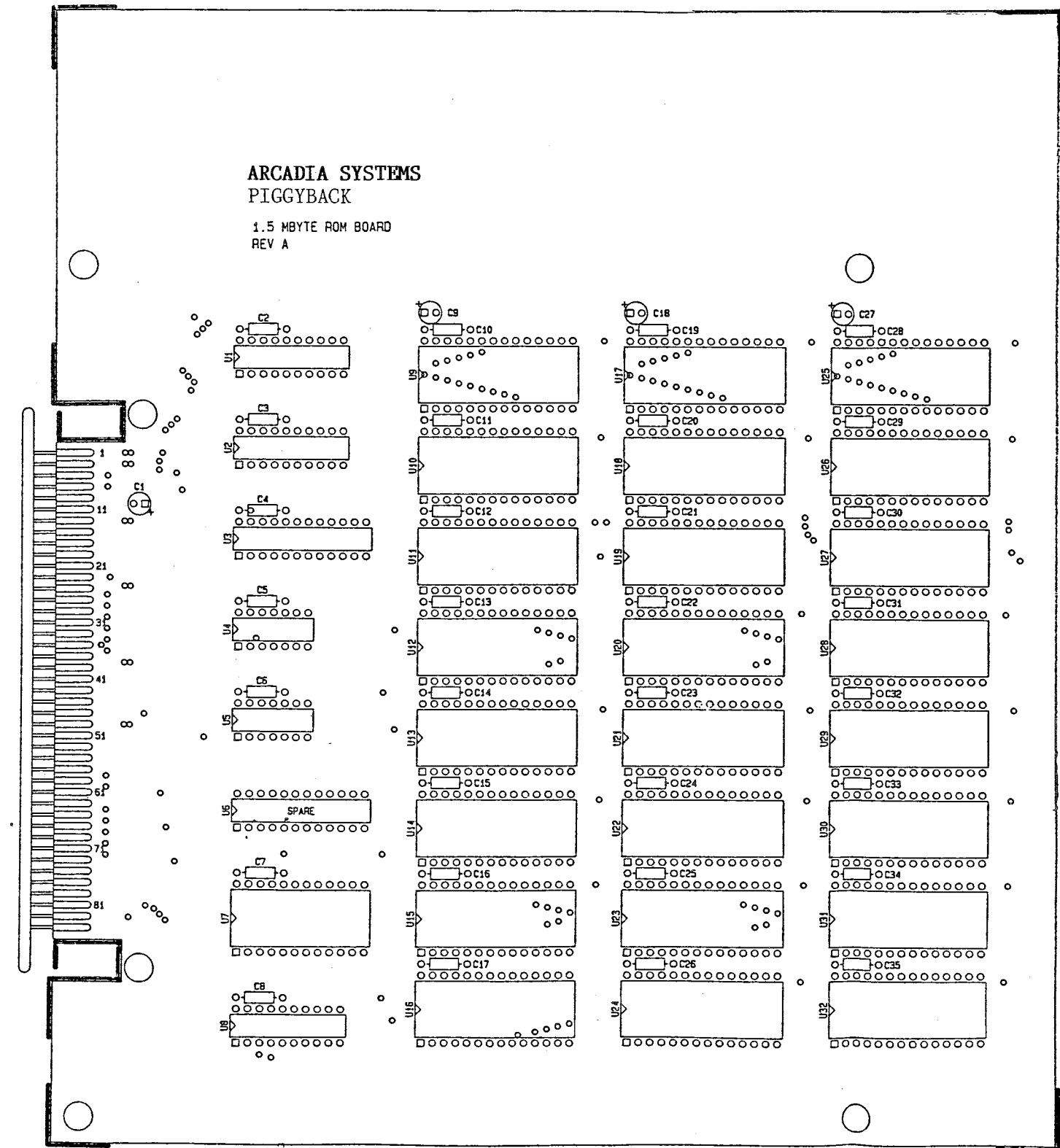

WARRANTY

Arcadia Systems warrants that the parts contained in its kits shall be free from defects in materials and workmanship for a period of sixty (60) days from date of shipment. Arcadia Systems' warranty of these parts is subject to the normal use and service of its product. No other products or parts thereof are warranted. If the products described in this manual fail to conform to this warranty, Arcadia Systems' sole liability shall be, as mutually agreed, to replace or repair such products which are returned to Arcadia Systems during the stated warranty period, provided:

1. Arcadia Systems is notified in writing upon discovery by the buyer that said products are defective.

2. The defective product or part is returned pre-paid to Arcadia's Customer Facility, with an Arcadia Returned Merchandise Authorization (RMA) number clearly visible on the outside of the package.

3. Arcadia's examination of returned products determines to our satisfaction that the alleged defects existed and were not caused by accident, misuse, neglect, alteration, improper repair, installation, or testing.

In no event shall Arcadia Systems be liable for loss of profits, loss of use, incidental or consequential damages.

Except for this warraanty, Arcadia Systems disclaims all other warranties, expressed or implied, including the implied warranties of merchantability and fitness for a particular purpose, and all other obligations or liabilities on Arcadia Systems' behalf, and it neither assumes nor authorizes any other person to assume for Arcadia Systems any other liabilities in connection with the sale of products furnished by Arcadia Systems.

ARCADIA *Systems*™

Old Mill Office Center
Suite D-263, 201 San Antonio Circle,
Mountain View, CA 94041
Telephone: (415) 949-5290
Telefax: (415) 949-0157
Telex: 910 240 9392 ARCADIA USA UQ