

centuri™ inc.



**SERVICE
MANUAL**

PART NO 370-10-0100

PLEIADES

CENTURI, INC

245 W. 74TH PLACE

HIALEAH, FL. 33014

TEL. #(305) 558-5200

CUSTOMER SERVICE:

TEL. #(305) 558-5200 (IN FLORIDA)

TEL. #(800) 327-7710 (OUTSIDE FLORIDA)

PLEIADES
TABLE OF CONTENTS

<u>I.</u>	<u>INTRODUCTION</u>	<u>PAGE NO.</u>
	USER INFORMATION - F.C.C.....	1
	GAME DESCRIPTION (DIAGRAM).....	2
	GAME SUMMARY.....	3,4
<u>II.</u>	<u>SPECIFICATIONS:</u>	
	INSTALLATION.....	4
	ELECTRICAL REQUIREMENTS.....	4
	110/220 VAC CONVERSION REQUIREMENTS.....	5
<u>III.</u>	<u>OPERATION:</u>	
	GAME INSTRUCTIONS.....	6
	*GAME SCORING.....	6
	OPERATOR OPTIONAL SWITCH SETTINGS.....	7
	OPTIONAL SWITCH SETTINGS.....	7
	ROUTINE MAINTENANCE AND SERVICE.....	8
	POWER SUPPLY.....	8
<u>IV.</u>	<u>GENERAL:</u>	
	C.P.U. PRINTED CIRCUIT BOARD PARTS LIST.....	9,10
	ROM A6 PRINTED CIRCUIT BOARD PARTS LIST.....	11
	POWER SUPPLY PARTS LIST.....	12,13
<u>V.</u>	<u>DRAWINGS AND SCHEMATICS:</u>	
	110/220 VAC POWER INTERCONNECT DIAGRAM..(370-10-0400).....	14
	C.P.U HARNES INTERCONNECT DIAGRAM.....(370-10-0600).....	15
	C.P.U PRINTED CIRCUIT BOARD MODIFICATION(370-10-0200).....	16
	SHINDENGEN POWER SUPPLY SCHEMATIC.....(363-17-0300).....	17
	C.P.U BOARD ASSEMBLY SCHEMATIC.....(370-17-0100).....	18
	ROM A6 BOARD ASSEMBLY SCHEMATIC.....(370-17-0200).....	19

USER INFORMATION - F.C.C.

WARNING:

THIS EQUIPMENT GENERATES, USES AND CAN RADIATE RADIO FREQUENCY ENERGY AND IF NOT INSTALLED AND USED IN ACCORDANCE WITH THE INSTRUCTIONS MANUAL, MAY CAUSE INTERFERENCE TO RADIO COMMUNICATIONS. AS TEMPORARILY PERMITTED BY REGULATION, IT HAS NOT BEEN TESTED FOR COMPLIANCE PURSUANT TO SUBPART J OF PART 15 OF F.C.C. RULES, WHICH ARE DESIGNED TO PROVIDE REASONABLE PROTECTION AGAINST SUCH INTERFERENCE. OPERATION OF THIS EQUIPMENT IN A RESIDENTIAL AREA IS LIKELY TO CAUSE INTERFERENCE IN WHICH CASE THE USER AT HIS OWN EXPENSE WILL BE REQUIRED TO TAKE WHATEVER MEASURES MAY BE REQUIRED TO CORRECT THE INTERFERENCE.

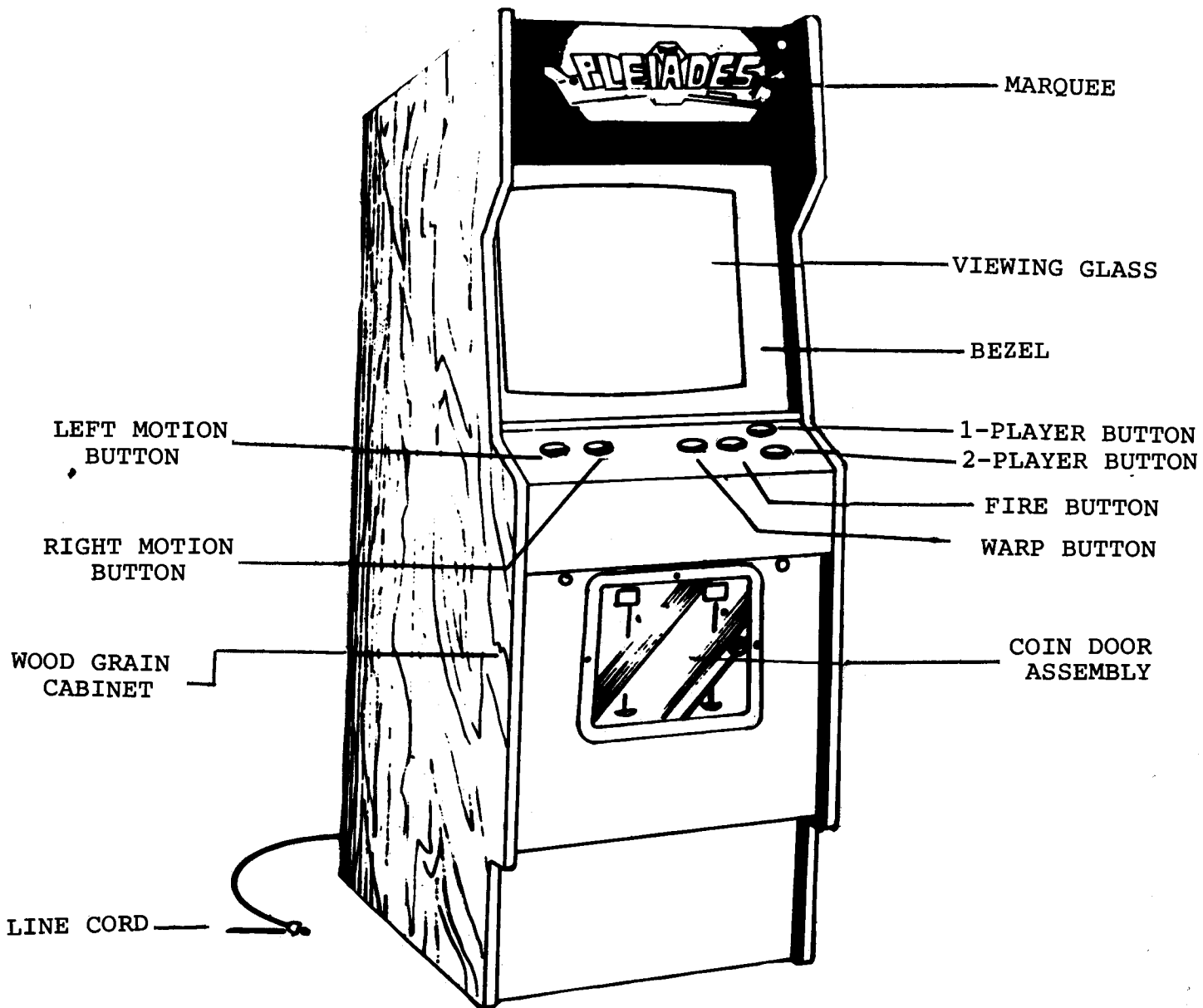

19" PLEIADES VIDEO UPRIGHT

PLEIADES

PLEIADES is the most recent of the Centuri video games. With its many interesting visual and audio effects, this game is sure to challenge the most avid player.

Each round of play includes four different stages. With the onset of the melodious background tune, the first stage of play begins.

Against a backdrop of planets and twinkling stars, the Earth City must be protected from sixteen attacking Martians. These Martian attackers have the ability to transform from flying Martians(30 points), to walking Martians(80 points), or to UFOs'(150 points). The walking Martians build barriers across the Earth City. These barriers must be destroyed.

The Earth Spaceship can be maneuvered right and left. With the use of the "warp" button, it can be randomly relocated when necessary. These, plus a backup of stationary defense weapons, aid in protecting the Earth City and Spaceship, as well as in destroying the Martian Attackers. When all but the two final Martians have been destroyed, a tone of dusk shades the Earth City. As these two attackers meet their end, the Earth Spaceship ascends into space to meet the challenge of Stage II.

In this second stage of play, the Earth Spaceship encounters eight Space Monsters(50-100 points). To destroy these Monsters, they must be hit in the direct center. When a Space Monster with burning wings is destroyed, up to 400 points can be added to your score. When all the Space Monsters have been destroyed, the Earth Spaceship prepares for Stage III.

In this third stage of play, the Earth Spaceship is confronted with the Martian Space Battleship and its unseen forces. This Martian Battleship contains five closed chambers, each protected by a rocket flame. Each chamber opens periodically at random, to release a defending reserve of Martian attackers. When a flame below an open chamber is extinguished, point value of the Martian Space Battleship increases. This enemy ship can be destroyed by either eliminating all sixteen Martian attackers, or by extinguishing all five rocket flames. When the Martian Space Battleship finally explodes, the Earth Spaceship moves on to Stage IV.

This last stage of play begins with an emergency signal, "SOS, SOS, SOS, AT ONCE RETURN TO EARTH". The Earth Spaceship is now ready to be guided on its journey, through a landing corridor, back to its home base. The Earth Spaceship must be carefully maneuvered around other spaceships in order to avoid destruction. Clearing flags will add bonus points to your score. When the Earth Spaceship has been safely maneuvered to its

arrival target, 500 to 4,000 points will be added to your score, while bursts of fireworks greet your arrival and signal the beginning of a new round of play.

When bonus levels are achieved, spaceships will be added to your score. The bonus levels may be adjusted to award spaceships at 3,000 and 30,000 points, or 4,000 and 40,000 points, or 5,000 and 50,000 points, or 6,000 and 60,000 points.

INSTALLATION

Your game was shipped from the factory in ready-to-play condition. A brief inspection is suggested before the machine is removed from the carton. If there is damage to the shipping carton contact the freight carrier for claim purposes. External damage could indicate possible damage to the cabinet and/or electronic components.

After the carton has been satisfactorily inspected, remove the machine from the shipping carton.

Examine the interior of the game for disconnected wires, cables, or harnesses, and make sure the electronic devices are securely mounted in their sockets, etc. Record the game serial number, since it will be required for reference and servicing.

ELECTRICAL REQUIREMENTS

Unless otherwise specified, this game is set to operate at 110 Volts A.C. See Figure -1- for 110/220 VAC conversion instructions.

Power Supply Chassis schematic information and parts list are included in this manual.

FIGURE -1-

110/220 VAC CONVERSION INSTRUCTIONS:

This video arcade game has a harnessing configuration that allows the machine to be operated from either a 110 VAC or 220 VAC @ 50 or 60Hz power source, with only minor changes. The only items requiring a change are the fuses and the jumper plug on the game power transformer.

- FIRST: Unplug the machine from the wall outlet to completely eliminate shock hazards.
- SECOND: Remove the two fuses in the A.C. distribution bracket.
- THIRD: Remove the jumper plug on the game power transformer located on the floor of the machine.
- FOURTH: Depending on what voltage you wish to run the game from, do the following:

110 VAC

Replace the two fuses that go in the bracket with the 3 AMP, SLOW-BLOW types. Next, plug in the orange jumper plug labeled 110 VAC. The machine can now be operated with an input voltage of 110 Volts A.C.

220 VAC

Replace the two fuses that go in the bracket with 1½-AMP, SLOW-BLOW types. Next, plug in the red jumper plug labeled 220 VAC. The machine can now be operated with an input voltage of 220 Volts A.C.

NOTE: All games shipped from CENTURI, INC. are in the 110 VAC configuration.

PLEIADES

GAME INSTRUCTIONS:

1. INSERT COIN(S).
2. SELECT 1-PLAYER OR 2-PLAYER BUTTON.
3. USE CONTROL BUTTONS TO MANEUVER SPACECRAFT LEFT AND RIGHT.
4. USE FIRE BUTTON TO DESTROY ATTACKING ALIENS.
5. WARP BUTTON WILL RANDOMLY RELOCATE SPACECRAFT DURING GAME PLAY.
6. PHASE I: DESTROY FROM GROUND BASE ALL ATTACKING ALIENS.
PHASE II. PROTECT SPACECRAFT BY DESTROYING ATTACKING SPACE MONSTERS WITH ROCKET FIRE. SPACE MONSTERS MUST BE HIT IN THE CENTER TO BE DESTROYED.
PHASE III. DESTROY SPACE BATTLE SHIP AND COSMIC ENEMIES WITH RAPID ROCKET FIRE.
PHASE IV. RETURN TO EARTH THROUGH LANDING CORRIDOR. MANEUVER AROUND OTHER SPACESHIPS TO AVOID DESTRUCTION. CLEARING BONUS FLAGS ADDS POINTS TO SCORE.
7. GAME IS OVER WHEN ALL SPACECRAFT ARE DESTROYED.

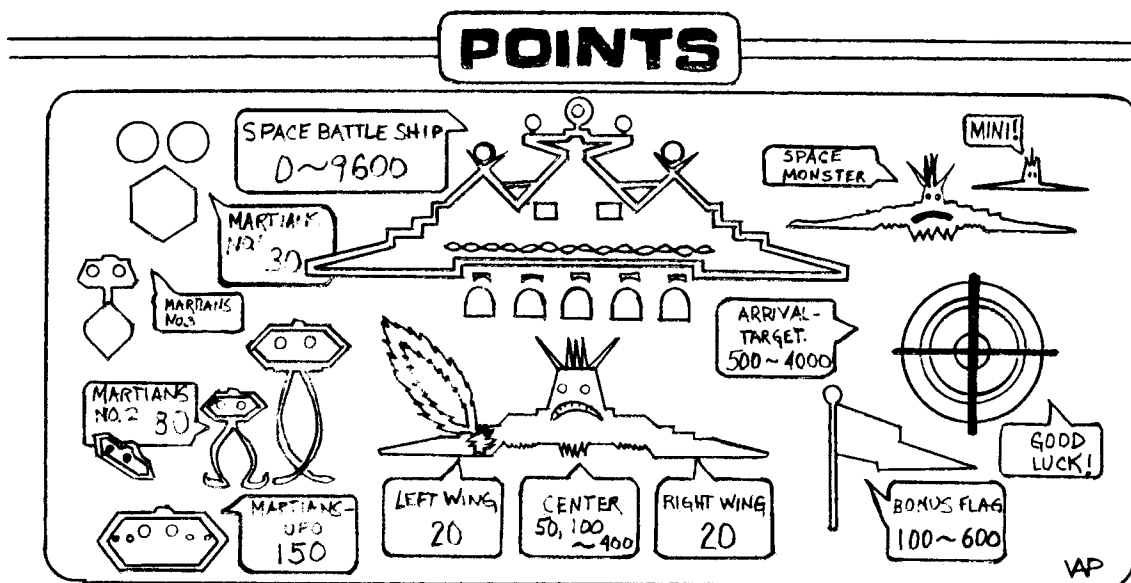

OPERATOR OPTIONAL SWITCH SETTINGS

The option switches are located on the CPU board. The option switches and audio control can be reached through the back of the machine.

The following settings will assist you with your selections:

OPTIONAL SWITCH SETTINGS

Switches 1 and 2 control the number of times the player may have his spaceship destroyed before the game is over. The following truth table lists these switch settings:

<u>SWITCH 1</u>	<u>SWITCH 2</u>	<u>NUMBER OF SPACESHIPS</u>
OFF	OFF	6
ON	OFF	5
OFF	ON	4
ON	ON	3

Switches 3 and 4 control the score at which one or two free spaceships are awarded according to the following truth table:

<u>SWITCH 3</u>	<u>SWITCH 4</u>	<u>FIRST FREE SHIP SCORE</u>	<u>SECOND FREE SHIP SCORE</u>
OFF	OFF	6,000	60,000
ON	OFF	5,000	50,000
OFF	ON	4,000	40,000
ON	ON	3,000	30,000

SWITCH 5: OFF- 25¢ PER GAME
ON- 50¢ PER GAME

SWITCH 6: FACTORY SETTING; REMAINS IN OFF POSITION

SWITCH 7: OFF- NO SOUND IN ATTRACT MODE
ON- SOUND IN ATTRACT MODE

SWITCH 8: OFF- UPRIGHT CABINET
ON- COCKTAIL TABLE

ROUTINE MAINTENANCE & SERVICE

Because of the solid state electronic circuitry, this machine should require very little maintenance and only occasional adjustments. However, it is necessary to take measures to insure this.

The volume control is located on the bottom side of the printed circuit board farthest from the side of the cabinet, and can be accessed through the rear door.

The video monitor has been properly adjusted before shipping. Occasionally minor adjustments are necessary. See monitor specifications and schematics for technical information. Adjustment controls for the monitor are located at the rear of the monitor.

This machine should be serviced only by a qualified technician.

Do not make any adjustments on this machine while the power is on.

For service information, contact:

CENTURI, INC.

Customer Service Department

#800-327-7710(Outside the state of Florida)

#305-556-5888(In Florida)

POWER SUPPLY

The computer Board in this game operates most efficiently and reliably when the power supply is set so that the voltage on the board is 5.0 Volts, ± 0.1 Volts. To check this, place a meter across 5 Volts and ground at the edge connector. If necessary, adjust the screwdriver control on the power supply so the meter reads between 4.9 and 5.1 Volts.

PARTS LIST

<u>NO.</u>	<u>PART NUMBER</u>	<u>DESCRIPTION:</u>	<u>USAGE:</u>
1.	50010249LS	74LS245 I.C.	1
2.	50010252LS	74LS374 I.C.	3
3.	50010273LS	74LS244 I.C.	2
4.	50010275LS	74LS136 I.C.	2
5.	50010248LS	74LS138 I.C.	2
6.	50010221LS	74LS163 I.C.	2
7.	50010002LS	74LS00 I.C.	3
8.	50010096LS	74LS08 I.C.	1
9.	50010141LS	74LS125 I.C.	1
10.	50010301LS	74LS32 I.C.	4
11.	50010170LS	74LS14 I.C.	1
12.	50010019LS	74LS74 I.C.	1
13.	50010030LS	74LS174 I.C.	1
14.	50010045	74157 I.C.	3
15.	50010197	7405 I.C.	1
16.	50010136	4066 I.C.	1
17.	50010142	7407 I.C.	1
18.	50010043	556 I.C.	4
19.	50010309	7910E I.C.	1
20.	50010231	BIPOLAR PROM: 7611-5 (HARRIS)	2
21.	50010277	8085 CPU	1
22.	50020003	LM380 I.C.	1
23.	50010254	LM324 I.C.	2
24.	50010281	MC14006B I.C.	1
25.	50010311	X-I.C.	1
26.	50010312	Y-I.C.	1
27.	50010313	Z-I.C.	1
28.	50040082	.047mfd, 25V., DISC CERAMIC CAPACITOR	6
29.	50040001	0.1mfd, 25V., DISC CERAMIC CAPACITOR	2
30.	50040049	.01mfd, 25V., DISC CERAMIC CAPACITOR	4
31.	50040066	470pf, 16V., DISC CERAMIC CAPACITOR	1
32.	50040011	0.001mfd, 16V., DISC CERAMIC CAPACITOR	7
33.	50040171	47pf, 16V., DISC CERAMIC CAPACITOR	1
34.	50060189	470mfd, 25V., ELECTROLYTIC AXIAL CAPACITOR	1
35.	50060190	47mfd, 25V., ELECTROLYTIC RADIAL CAPACITOR	5
36.	50060191	10mfd, 16V., DIPPED TANTALUM CAPACITOR	12
37.	50060192	6.8mfd, 16V., DIPPED TANTALUM CAPACITOR	4
38.	50060193	2.2mfd, 16V., DIPPED TANTALUM CAPACITOR	2
39.	50040172	.01mfd, 16V., MYLAR CAPACITOR	1
40.	50040173	.001mfd, 16V., MYLAR CAPACITOR	1
41.	50040174	0.1mfd, 25V., MYLAR CAPACITOR	14
42.	50120004	10K PCB TRIMMER POTENTIOMETER	1
43.	50360007	5 PIN RESISTOR PACK, 1K OHM	1
44.	50360006	9 PIN RESISTOR PACK, 1K OHM	3
45.	50030256	100 OHM, 1/4W., 5% RESISTOR	8
46.	50030051	1K OHM, 1/4W., 5% RESISTOR	18
47.	50030063	10K OHM, 1/4W., 5% RESISTOR	13
48.	50030014	270 OHM, 1/4W., 5% RESISTOR	7
49.	50030150	47K OHM, 1/4W., 5% RESISTOR	4
50.	50030095	330 OHM, 1/4W., 5% RESISTOR	4

PARTS LIST

<u>NO.</u>	<u>PART NUMBER</u>	<u>DESCRIPTION:</u>	<u>USAGE:</u>
51.	50030007	100K OHM, ¼W., 5% RESISTOR	7
52.	50030010	470 OHM, ¼W., 5% RESISTOR	1
53.	50030086	33K OHM, ¼W., 5% RESISTOR	3
54.	50030265	510K OHM, ¼W., 5% RESISTOR	6
55.	50030215	20K OHM, ¼W., 5% RESISTOR	16
56.	50030276	270K OHM, ¼W., 5% RESISTOR	1
57.	50030195	2K OHM, ¼W., 5% RESISTOR	3
58.	50030275	200K OHM, ¼W., 5% RESISTOR	3
59.	50030152	150 OHM, ¼W., 5% RESISTOR	3
60.	50150111	16-PIN SOLDER TRAIL SOCKET, LOW PROF.	5
61.	50150060	40-PIN SOLDER TRAIL SOCKET, LOW PROF.	1
62.	50150110	14-PIN SOLDER TRAIL SOCKET, LOW PROF.	1
63.	50130034	8 POSITION DIP SWITCH	1
64.	50150256	50-PIN PCB HEADER, AINSLEY #609-5007ES	2
65.	50210224	PRINTED CIRCUIT BOARD- CPU	1
66.	50100014	1N914 DIODE-D1-8	8
67.	50170050	INSULATED WIRE, 30AWG., (FOR MOD.)	30"
68.	50030148	39K OHM, ¼W., 5% RESISTOR	1

PARTS LIST

<u>NO.</u>	<u>PART NUMBER</u>	<u>DESCRIPTION:</u>	<u>USAGE:</u>
1.	50010221LS	74LS163 I.C.	4
2.	50010022LS	74LS86 I.C.	4
3.	50010262LS	74LS283 I.C.	3
4.	50010096LS	74LS08 I.C.	1
5.	50010248LS	74LS138 I.C.	2
6.	50010252LS	74LS374 I.C.	3
7.	50010002LS	74LS00 I.C.	1
8.	50010019LS	74LS74 I.C.	1
9.	50010093LS	74LS151 I.C.	4
10.	50010030LS	74LS174 I.C.	4
11.	50010249LS	74LS245 I.C.	2
12.	50010237LS	74LS244 I.C.	1
13.	50010005	7404 I.C.	1
14.	50010045	74157 I.C.	4
15.	50010310	2114 I.C. (200ns)	8
16.	50010171	2716 I.C. (EPROM SINGLE SUPPLY)	12
17.	50030004	1.2K OHM, $\frac{1}{4}$ W., 5% RESISTOR	2
18.	50030256	100 OHM, $\frac{1}{4}$ W., 5% RESISTOR	1
19.	50060190	47mfd, 25V., RADIAL LYTIC CAPACITOR	1
20.	50040174	0.1mfd, 25V., MYLAR CAPACITOR	14
21.	50040066	470pf, 16V., DISC CERAMIC CAPACITOR	2
22.	50040141	1000pf, 50V., DISC CERAMIC CAPACITOR	2
23.	50040142	150pf, 50V., DISC CERAMIC CAPACITOR	1
24.	50150061	24-PIN SOLDER TRAIL SOCKET, LOW PROF.	12
25.	50150256	50-PIN PCB HEADER, AINSLEY #609-5007ES	2
26.	50070014	11.000 MHZ CRYSTAL	1
27.	50210225	ROM PRINTED CIRCUIT BOARD	1

PARTS LIST - SHINDENGEN POWER SUPPLY

<u>SYMBOL:</u>	<u>DESCRIPTION:</u>	<u>USAGE:</u>
T1	TRANSFORMER, SINGLE PHASE, 2A VA	1
L1	CHOKING COIL, 1.6mH, 1.5A	1
L2, L4	CHOKING COIL, SF-T8-50S-03	2
L3	CHOKING COIL, SF-HP-2A-03	1
D1	DIODE, V19G	1
D2	DIODE, V06C	1
D3, D6	DIODE, 1S1588	2
D4	DIODE, S15S3	1
D5, D7	DIODE, 5CH1M	2
D12, D13	DIODE, F113B	2
D14	DIODE, F113B	1
RF1	DIODE, S4VB40 (BRIDGE TYPE)	1
Q1	TRANSISTOR, 2SC2504	1
Q2	TRANSISTOR, 2SD467(B)	1
Q3	TRANSISTOR, 2SC460(B)	1
Q4	TRANSISTOR, 2SA673(B)	1
IC1	INTEGRATED CIRCUIT, RM723DC or HA17723G-02	1
PC1	PHOTO COUPLER, PS2001	1
R1	RESISTOR, 2 WATT, 18 OHM	1
R8, R9	RESISTOR, 2 WATT, 47K OHM	2
R3, 1-4	RESISTOR, 2 WATT, 15 OHM	4
R4	RESISTOR, 1 WATT, 56 OHM	1
R12	RESISTOR, 1 WATT, 100 OHM	1
R28	RESISTOR, 1 WATT, 470 OHM	1
R7	RESISTOR, 1 WATT, 0.56 OHM	1
R26	RESISTOR, 1 WATT, 0.82 OHM	1
R23	RESISTOR, 1/4 WATT, 22 OHM	1
R10	RESISTOR, 1/4 WATT, 33 OHM	1
R27	RESISTOR, 1/4 WATT, 68 OHM	1
R2	RESISTOR, 1/4 WATT, 330-470 OHM	1
R22	RESISTOR, 1/4 WATT, 220 OHM	1
R21	RESISTOR, 1/4 WATT, 270 OHM	1
R6	RESISTOR, 1/4 WATT, 330 OHM	1
R11	RESISTOR, 1/4 WATT, 68 OHM	1
R20	RESISTOR, 1/4 WATT, 470 OHM	1
R17	RESISTOR, 1/4 WATT, 680 OHM	1
R19	RESISTOR, 1/4 WATT, 800 OHM	1
R18	RESISTOR, 1/4 WATT, 1.2K OHM	1
R5	RESISTOR, 1/4 WATT, 10K OHM	1
R16	RESISTOR, 1/4 WATT, 220K OHM	1
R29	RESISTOR, 3 WATT, 27 OHM	1
R39	RESISTOR, 1/4 WATT, 4.7K OHM	1
R38	RESISTOR, 1/4 WATT, 5.6K OHM	1
R24	RESISTOR, 1/4 WATT, 330 OHM	1
R25	RESISTOR, 1/4 WATT, 150 OHM	1
RV1	VARIABLE RESISTOR, RJ-6P501	1

PARTS LIST - SHINDENGEN POWER SUPPLY

<u>SYMBOL:</u>	<u>DESCRIPTION:</u>	<u>USAGE:</u>
C1, C2	CAPACITOR, ECK-DAL102E	2
C3-1,-2	CAPACITOR, 160VSN100	2
C9, C10	CAPACITOR, SM10VB-2200	2
C11, C23	CAPACITOR, SM10VB-2200	2
C12, C13, C15	CAPACITOR, SL25VB-10	3
C27	CAPACITOR, SL25VB-10	1
C18, C19, C20	CAPACITOR, SM35VB-1000	3
C26	CAPACITOR, SM35VB-1000	1
C21, C22, C25	CAPACITOR, SM16VB-1000	3
C5	CAPACITOR, DMY21H472K	1
C6	CAPACITOR, DMY21H104K	1
C14, C16	CAPACITOR, DMY21H222K	2
C4	CAPACITOR, CM20XC511K5	1
C8	CAPACITOR, MDD22G473K	1
C5-2	CAPACITOR, DMY21H222K	1
F1, F2	ENCLOSED TYPE FUSE, 3A	2

THE MATERIAL CONTAINED HEREIN IS CONFIDENTIAL AND NO PART OF IT CAN BE REPRODUCED WITHOUT THE EXPRESSED PERMISSION OF CENTURI, INC.

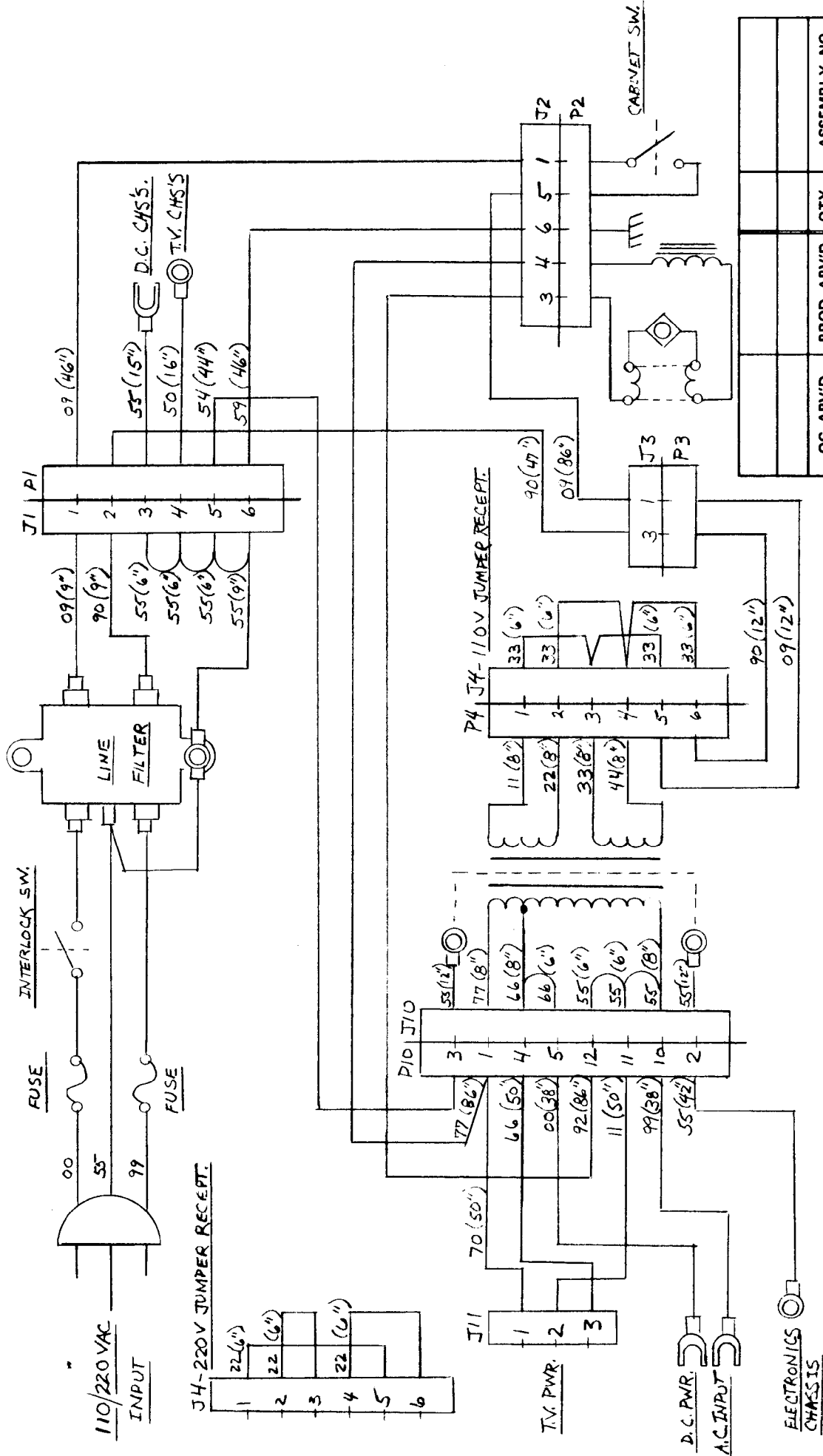

REV. LET.		ECN NO.	REVISION	BY	TOLERANCES		centuri inc.		HIALEAH, FLORIDA 33014	
					Unless Otherwise Specified					
					FRACTIONS	± 1/32				
					DECIMALS 2 PL	± .015			NAME PLEIADES-19" 110/220V POWER INTERCONNECT CHASSIS	
					DECIMALS 3 PL	± .005			MATERIALS HEAT TREAT. FINISH	
					HOLES	+ .003				
					ANGLES	- .001				
					SHT. MET BENDS	± 1/2"				
						± 2"				
REV. LET.		ECN NO.	REVISION	BY	DWN VAP	DATE 5-8-81	SCALE	PART NO. 370-10-0400	QTY.	ASSEMBLY NO.
					VAP					

27 17899A

THE MATERIAL CONTAINED HEREIN IS CONFIDENTIAL AND NO PART OF IT CAN BE REPRODUCED WITHOUT THE EXPRESSED PERMISSION OF CENTURI, INC. TO SPEAKER

1 2 3 3 PIN MOLEX RECEPTOR

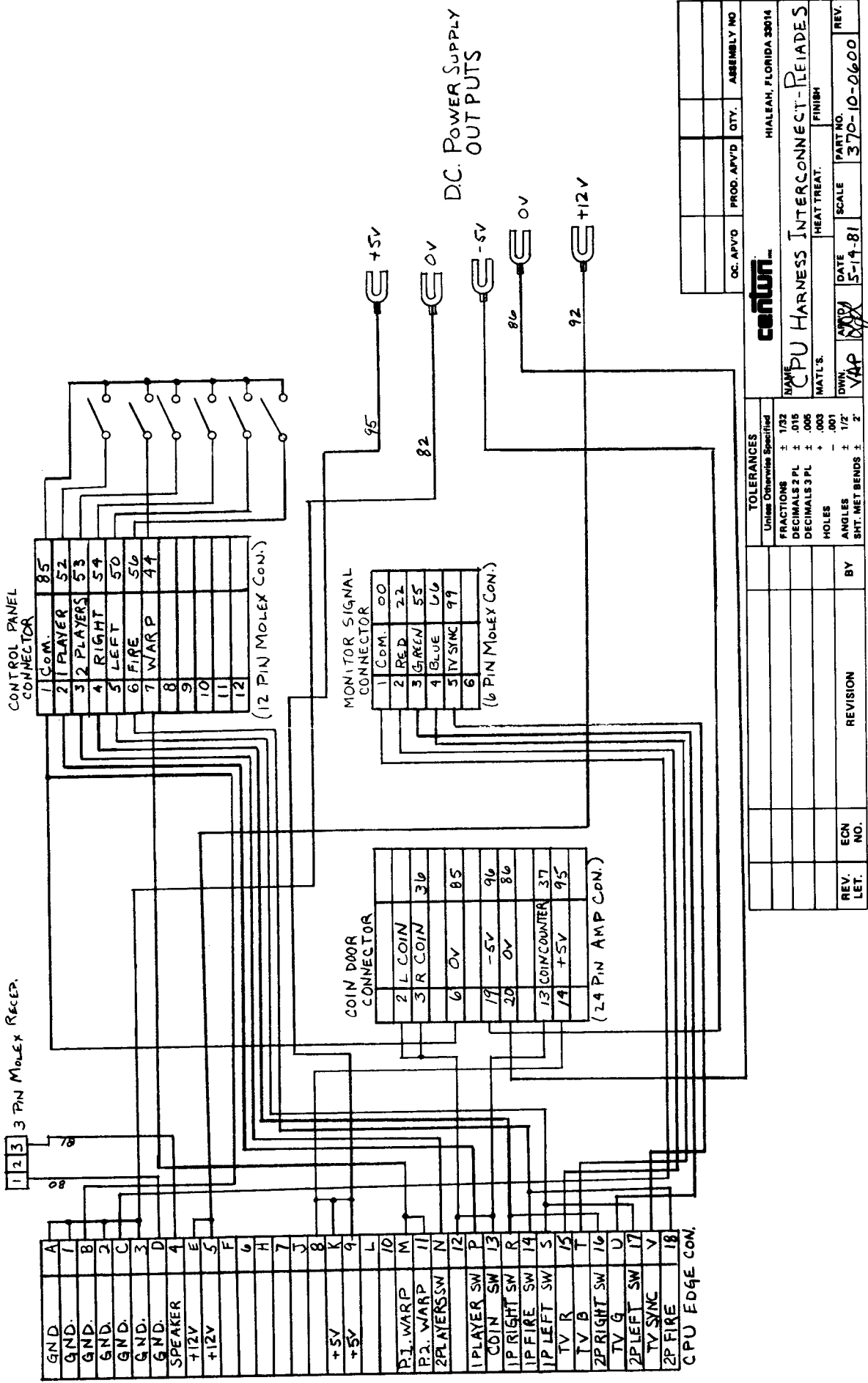

TOLERANCES Unless Otherwise Specified		OC. APVO	PROD. APV'D	QTY.	ASSEMBLY NO.
FRACTIONS	± 1/32				
DECIMALS 2 PL	± .015				
DECIMALS 3 PL	± .005				
HOLE S.	± .003				
ANGLES	± .001				
BHT. MET BENDS	± 1/2°				
centuri.					
HIALEAH, FLORIDA 33014					
NAME	CPU HARNESS INTERCONNECT-REIADAES	DATE	5-14-81	PART NO.	370-10-0600
MAT'L S.		HEAT TREAT.		FINISH	
DWN.	VAP	APV'D		REV.	

THE MATERIAL CONTAINED HEREIN IS CONFIDENTIAL AND NO PART OF IT CAN BE REPRODUCED WITHOUT THE EXPRESSED PERMISSION OF CENTURI, INC.

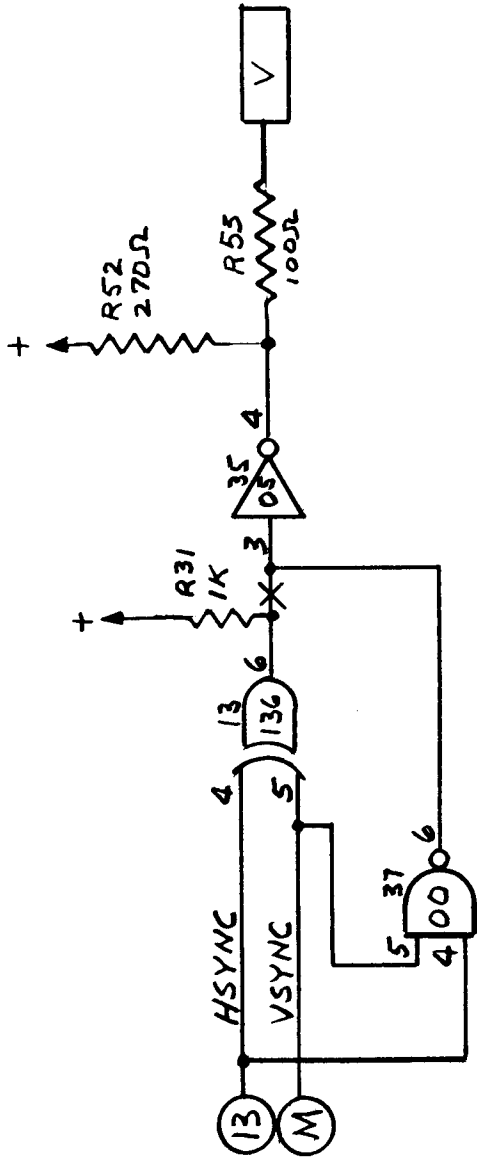

- 1. PIN 5 OF IC 13 TO PINS 5 OF IC 37
 - 2. PIN 4 OF IC 13 TO PIN 4 OF IC 37
 - 3. PIN 6 OF IC 37 TO PIN 3 OF IC 35
- CUT TRACE TO PIN 3 OF IC 35

REV. LET.	ECN NO.	REVISION	BY						
				centuri inc.					
				HIALEAH, FLORIDA 33014					
				NAME PLEIADES CPU BOARD MODIFICATION					
				MATERIALS HEAT TREAT. FINISH					
DWN. AAN	APPR. <i>[Signature]</i>	DATE 5-6-81	SCALE 1/2"	PART NO. 370-10-200	QTY.		PROD. APV'D	ASSEMBLY NO	REV.
				TOLERANCES Unless Otherwise Specified					
				FRACTIONS	±	1/32			
				DECIMALS 2 PL	±	.015			
				DECIMALS 3 PL	±	.005			
				HOLES	±	.003			
				ANGLES	±	1/2°			
				SHT. MET BENDS	±	2°			

REVISIONS		DISPOSITION OF EXISTING PARTS		ENGR'G	
ECN NO.	DESCRIPTION	RE-	SCRAP	RE-	SCRAP
ITEM NO.	LETTER	WORK		WORK	

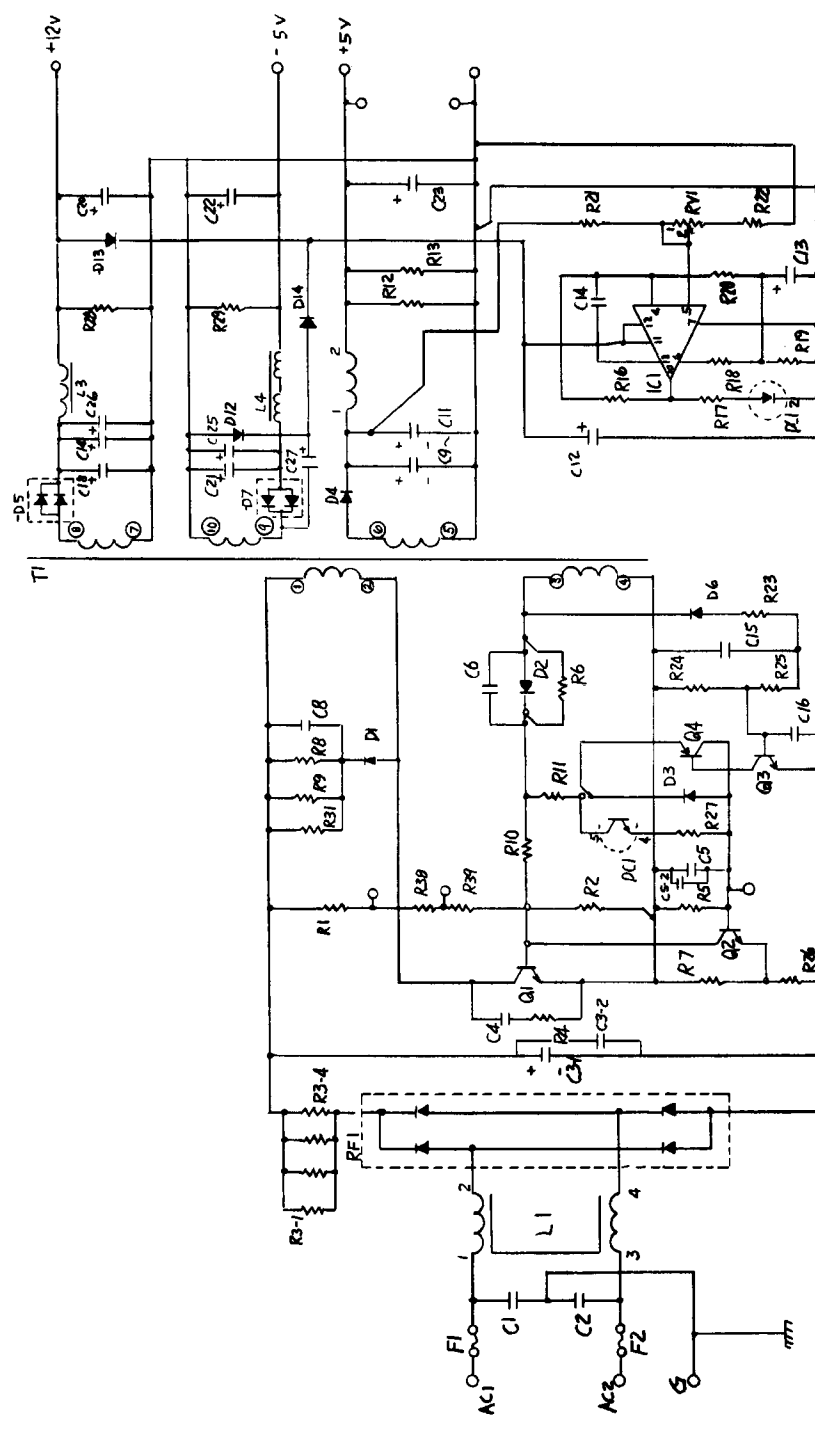

TOLERANCES - UNLESS OTHERWISE SPECIFIED	
FRACTIONS	± 1/32
DECIMALS	± .03
DECIMALS	± .010
HOLES	± .002
ANGLES	± 1/2

DATE	SCALE	DWG NO.	REV
1-12-81	1:1	363-17-0300	1

ALLIED LEISURE INDUSTRIES INC.	
1780 W. 41st AVENUE HIALEAH, FLORIDA 33010	
TITLE: SHINDENGEN POWER SUPPLY SCHEMATIC	
DWN	APP'D
AAN	SOB

NEXT ASSEMBLY

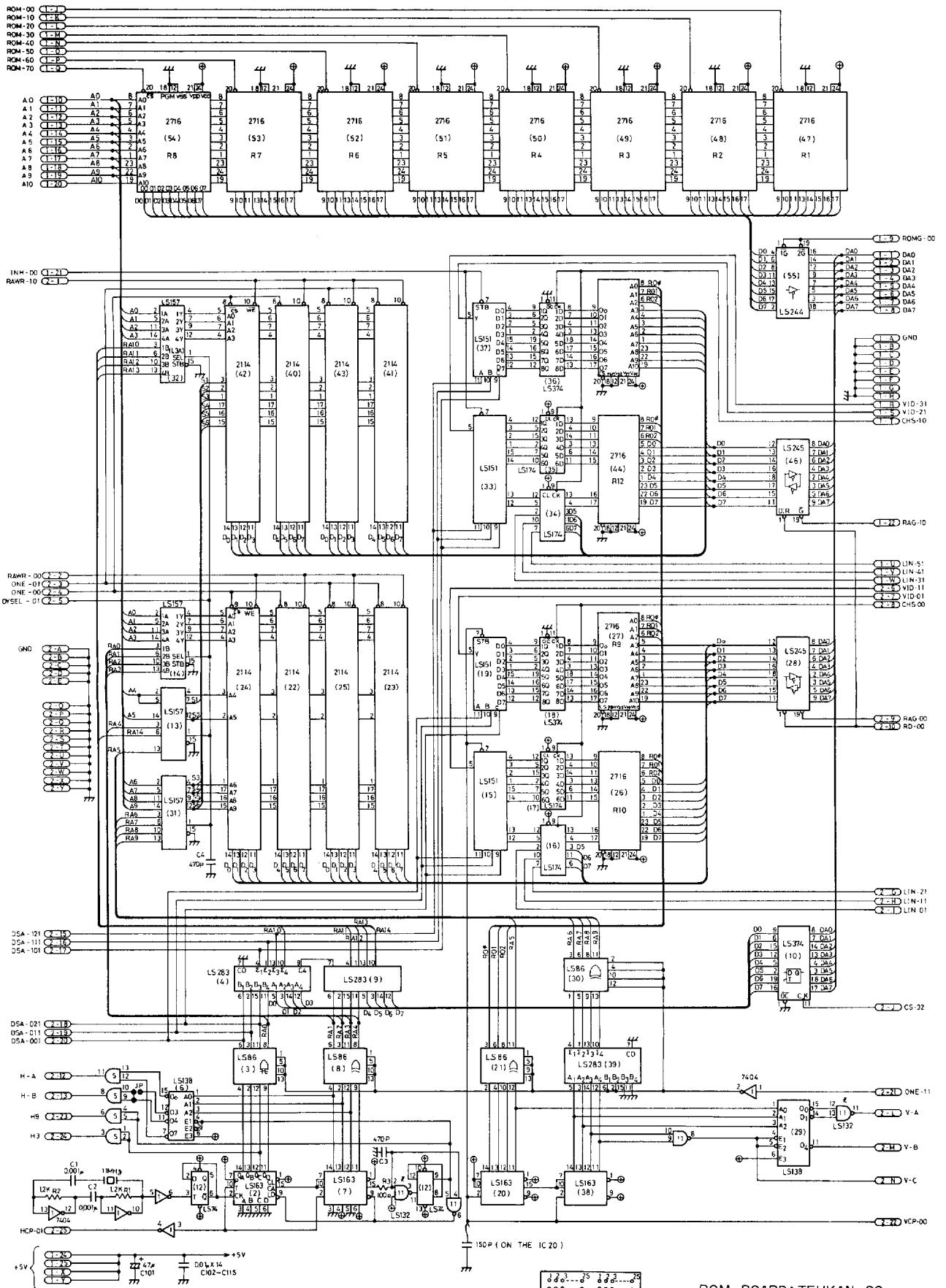

ROM BOARD; TEHKAN-02

REV.	EQN. NO.	REVISION	BY	AMOUNT	DATE	REMARKS

TOLERANCES		UNLESS OTHERWISE SPECIFIED	
FRACTIONS	1/32	DECIMALS	0.005
ORIGINALS P.L.	0.010	ORIGINALS P.L.	0.010
MOULDS	0.005	MOULDS	0.005

IC. APP'D	PROG. APP'D	OFF.	ASSEMBLY NO.

REV.	EQN. NO.	REVISION	BY	AMOUNT	DATE	REMARKS