

No Man's Land

OPERATION and MAINTENANCE Manual



Gottlieb
AMUSEMENT GAMES

165 W. Lake Street, Northlake, IL 60164
(312) 562-7400 Telex 72-8463
A Columbia Pictures Industries Company 

© 1980 D. Gottlieb & Co.
All Rights Reserved
Printed in U.S.A.

TABLE OF CONTENTS

	PAGE
GAME PLAY	1
GAME POWER UP AND OPERATION	
A. POWER SWITCHES	2
B. GAME POWER UP	2
C. GAME OPERATION	2-3
D. RESET SWITCH AND SLAM SWITCH	3
E. VOLUME CONTROL.....	3
OPTION DIP SWITCHES	4
POWER SUPPLY DIAGRAM	5
SYSTEM BLOCK DIAGRAM	5
MAIN CIRCUIT BOARD DIAGRAM	6-9
SOUND BOARD DIAGRAM	10
I.C. LOCATION AND PARTS LISTS	11-15

GAME PLAY

1. Destroy the assaulting enemy tanks by maneuvering your tank (with the control stick) and firing your tank cannon (with the fire button). Score is accumulated by destroying enemy tanks.
2. Your tank can move and fire in eight directions but the enemy tanks can move and fire in only four directions. Your tank can move and fire diagonally.
3. Each time an assaulting enemy tank is destroyed, a reserve tank located at the top of the screen is alerted (flickers) and joins the remaining assaulting tanks.
4. By dodging assaulting tank fire, you can penetrate the reserve tank positions and destroy them accumulating a higher score.
5. As the number of reserve tanks decreases either by joining the assaulting tanks or by being destroyed, the speed of the remaining assaulting tanks increases.
6. Your score progressively increases as the number of screens cleared increases. When you destroy a reserve tank, you are awarded a score twice as high as that awarded when you hit an assaulting tank.

Number of Screens Cleared	Assaulting Tank	Reserve Tank
1	100 Pts.	200 Pts.
2	150 Pts.	300 Pts.
3	200 Pts.	400 Pts.
4	250 Pts.	500 Pts.
5	300 Pts.	600 Pts.
6	350 Pts.	700 Pts.
7	400 Pts.	800 Pts.
8	450 Pts.	900 Pts.

7. Dependent on the option switch setting, an extra tank can be awarded after accumulating a set amount of points.

GAME POWER-UP AND OPERATION

A. POWER SWITCHES

The game On-Off Switch is located on the top of the cabinet in the right rear corner. Switching it on applies power to the game.

The Interlock Power Switch is mounted in the cabinet on the lower left side (facing the rear). With the rear panel in place, the interlock switch is on, allowing power to the game. With the rear panel removed, the interlock switch is off and no power is applied to the game no matter what the position of the On-Off Switch. The Interlock Switch can be overridden when the rear panel is off by pulling the switch plunger. Power is now applied to the game with the rear panel off.

B. GAME POWER-UP

- 1) Remove the rear panel and lift the line cord out of the cabinet insuring that the cord is placed in the slot at the bottom of the cabinet. Plug the AC power line cord into a properly grounded 3-wire receptacle of the correct voltage.
- 2) Set option switches on the main control board for desired game features. See option switch setting tables.
- 3) Adjust the volume control knob located on the sound circuit board. See Fig. 2. Turn the knob approximately 1/4 turn from the low volume position.
- 4) Replace the rear panel. Position the game and level. Turn the On-Off Switch on. The game is ready to be played.

C. GAME OPERATION

- 1) Insert coin(s) into coin chute(s). Credits will be displayed at lower right of screen. Option dip switches will determine coin/credit combination.
- 2) Push the one player or the two players button. Two players button uses two credits. Player buttons are located on the right side of the control panel.
- 3) Assaulting tank and reserve tank score will be displayed momentarily.
- 4) Number of player tanks remaining is displayed at lower left of the screen.
- 5) 1st player score is located at the upper left corner of the screen. 2nd player score is located at upper right of screen.
- 6) Hi score is positioned between 1st and 2nd players score.
- 7) Player-up score will flash. Flashing stops when player begins to score.

D. RESET SWITCH AND SLAM SWITCH

The reset and slam switches are both normally open switches located on the front door of the cabinet. Pressing the reset pushbutton switch by the operator or closing the slam switch through pounding on the front door will cause the game to go "Game Over" for all players. All credits will be lost and hi score will be erased and reset to zero. NOTE: Turning the game off then on will give the same result as the reset and slam switch.

E. VOLUME CONTROL

Volume is adjusted by the volume control knob on the sound circuit board.

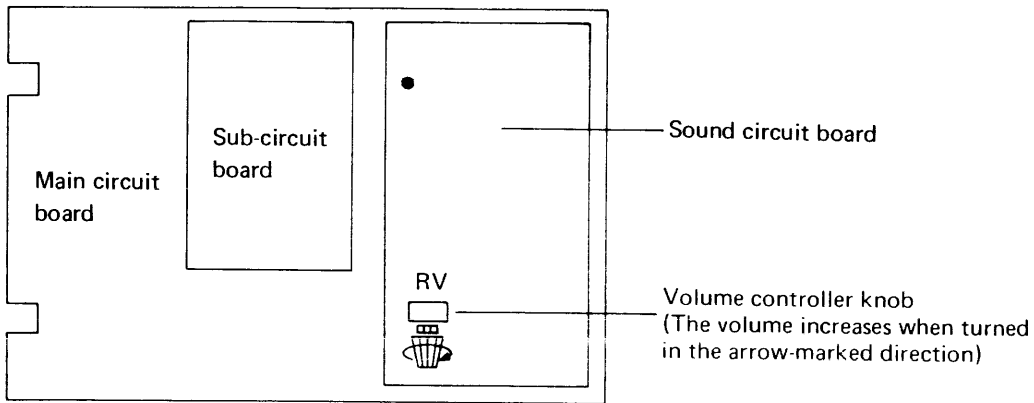

Fig. 2 Position of Volume Controller Knob

WARNING: Do not plug the Video Monitor directly into an AC line power receptacle.

A. POSITIONS OF DIP SWITCHES

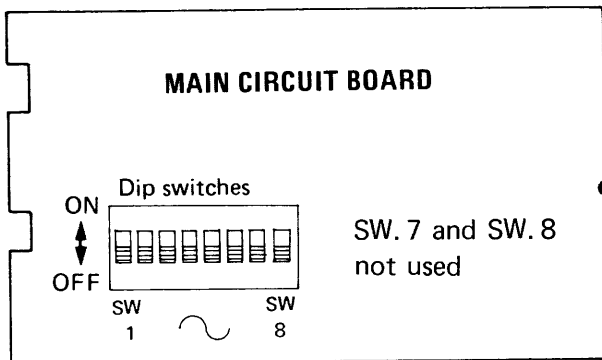

Fig. 1 Positions of Dip Switches

B. SETTING THE OPTION (DIP SWITCHES)

1. Change-over setting of the mode of game (SW1)

Style	SW1
Table	OFF
Stand up table	OFF
Upright	ON

3. Setting the game charge (Coin & Credit) (SW 3, 4)

Coin, Credit	SW3	SW4
1 coin 1 credit	ON	ON
1 coin 2 credits	OFF	ON
2 coins 1 credit	ON	OFF
4 coins 4 credits	OFF	OFF

2. Setting the number of tanks for game (SW2)

Number of tanks	SW2
2 tanks	ON
3 tanks	OFF

(Set at 3 tanks when shipped)

4. Setting the required score for an additional tank (SW 5, 6)

Score for Extra	SW5	SW6
3000	ON	OFF
5000	OFF	ON
8000	OFF	OFF
No extra	ON	ON

POWER SUPPLY DIAGRAM

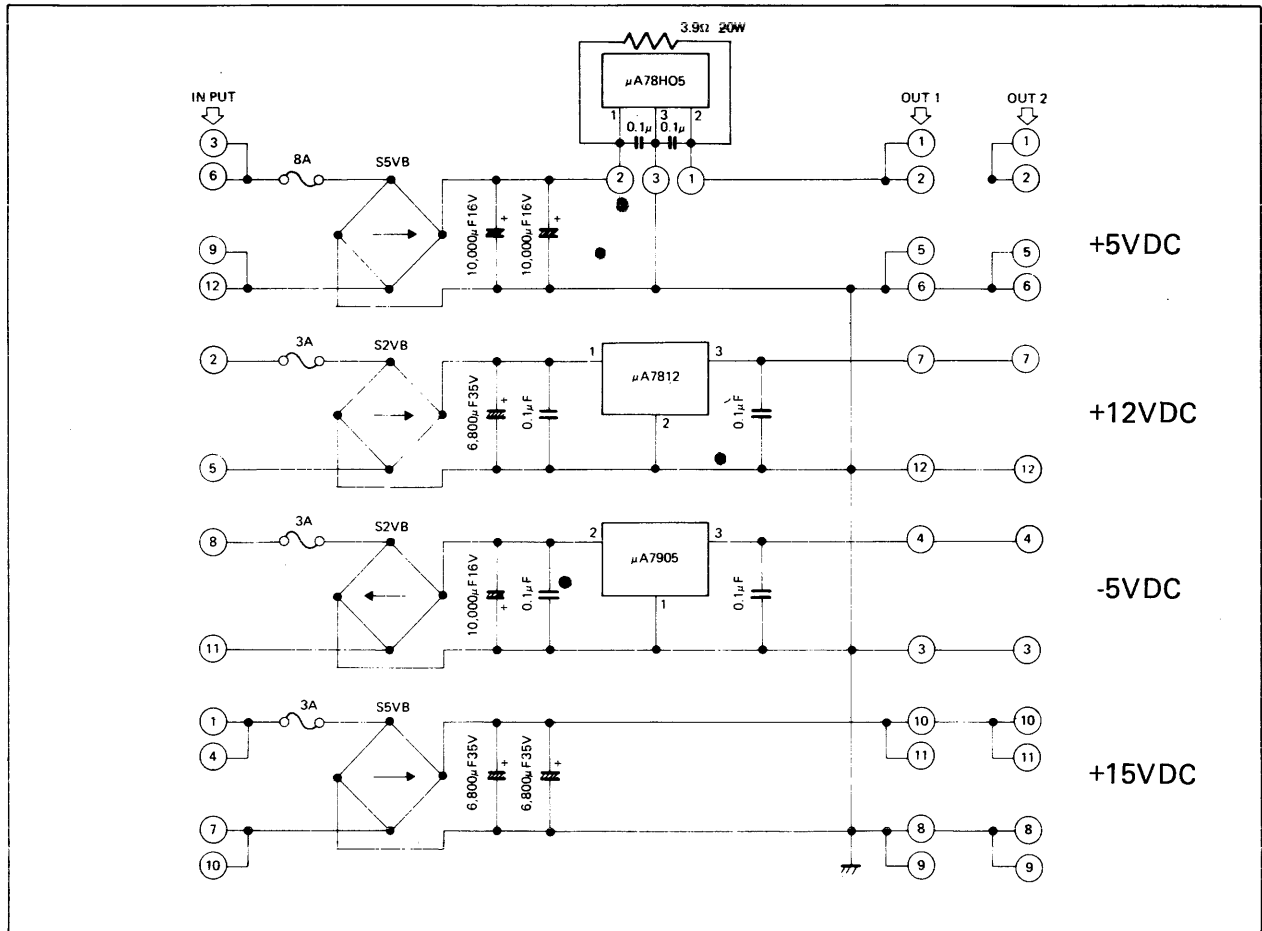

BLOCK DIAGRAM

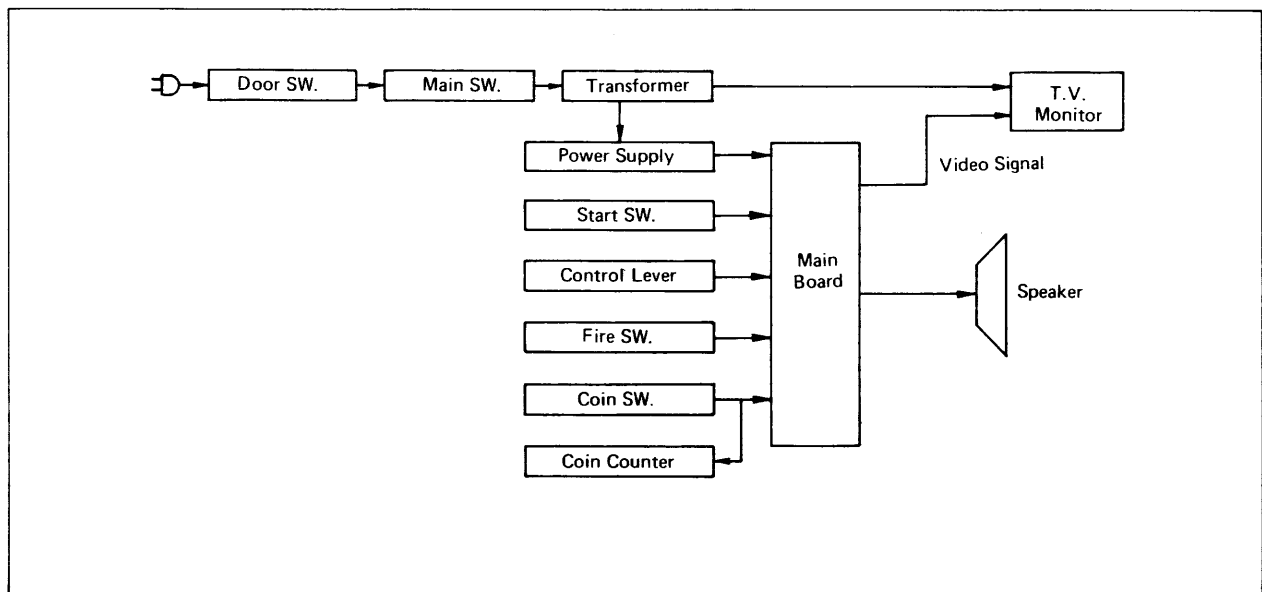

NO MAN'S LAND
8003

MAIN BLOCK DIAGRAM

No. 1

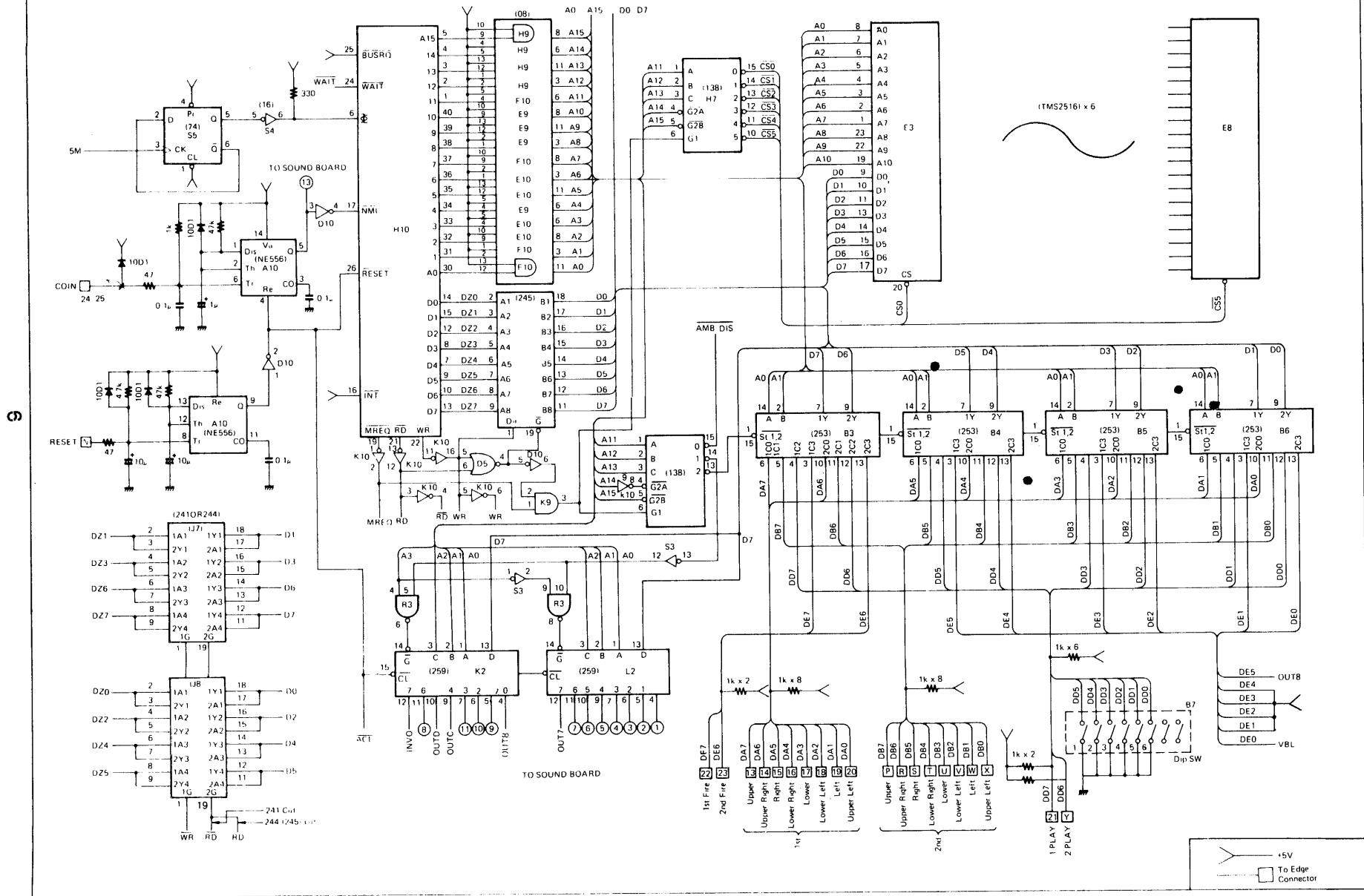

CONTROL BOARD DIAGRAM

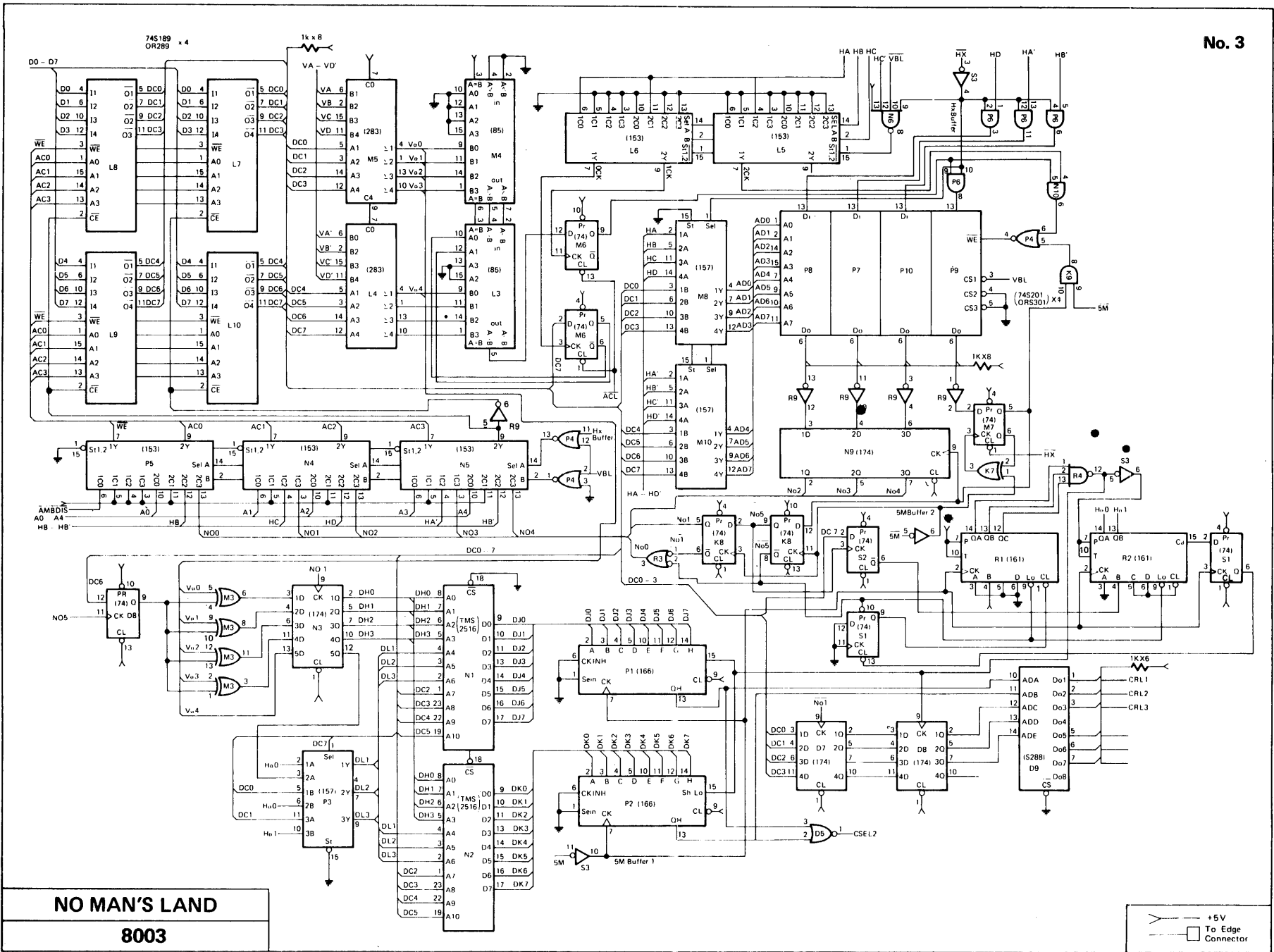

NO MAN'S LAND

8003

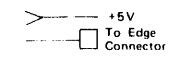

NO MAN'S LAND

8003

No. 4

CONTROL BOARD DIAGRAM

6

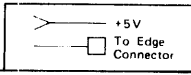
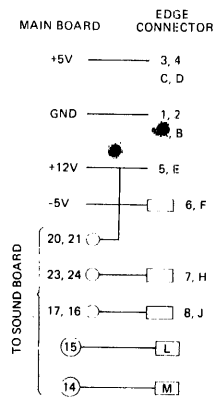
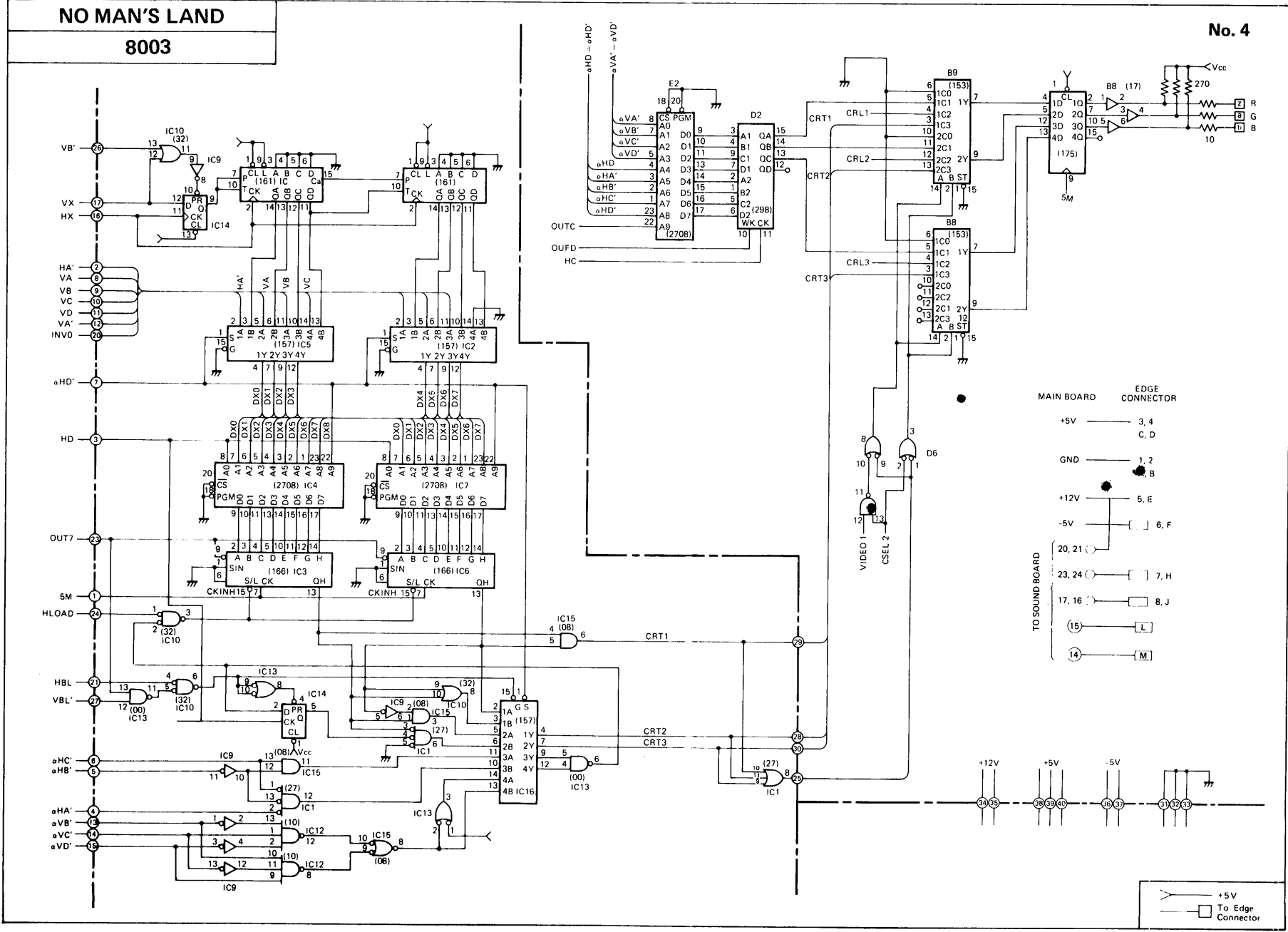

SOUND BLOCK DIAGRAM

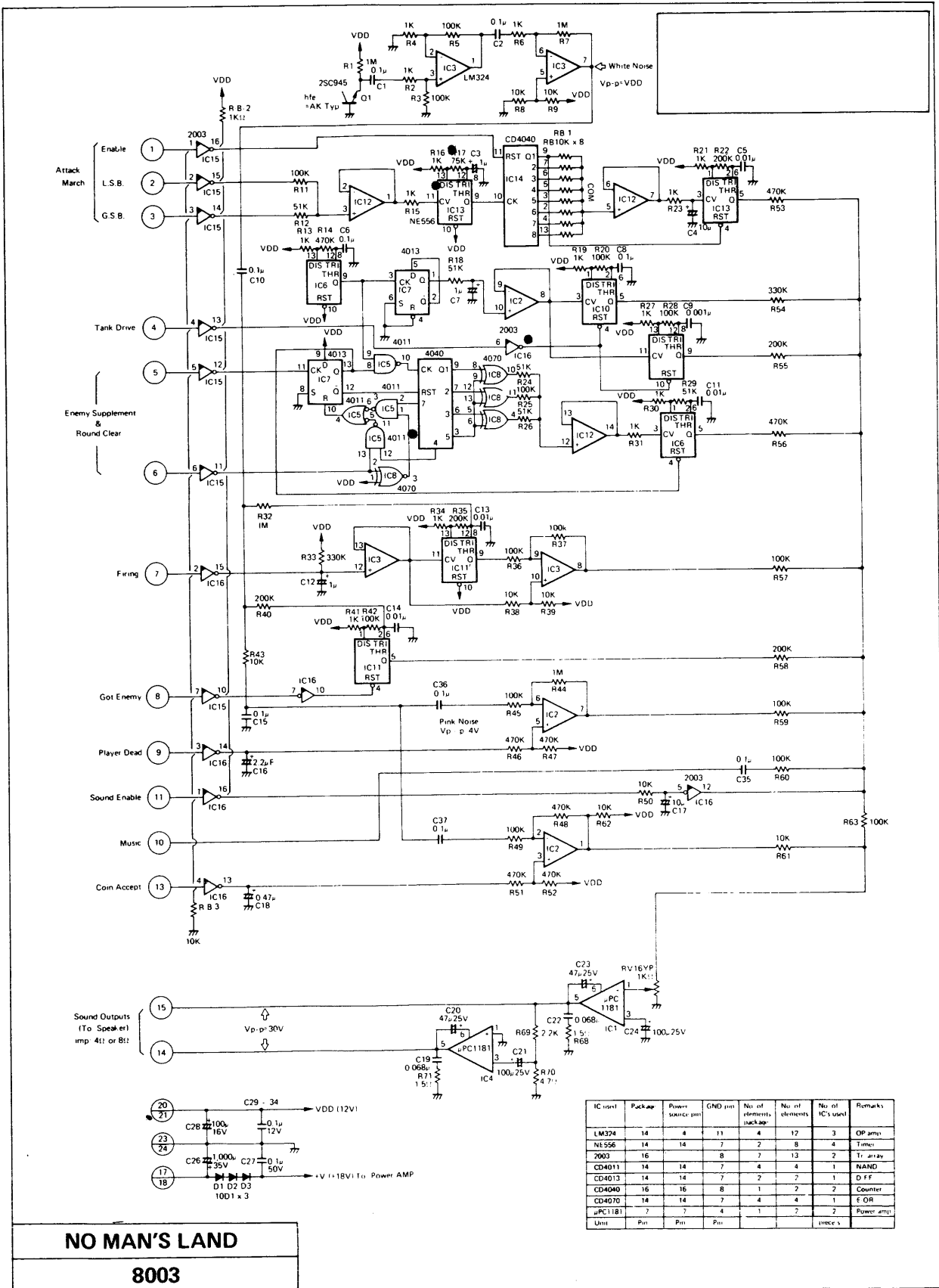

MAIN CIRCUIT BOARD PARTS LIST

[1] Integrated Circuit

Item No.	Q'ty	Description
7400N	4	Transistor Logic
7402N	2	"
7404N	7	"
7408N	7	"
7410N	2	"
7416N	1	"
7417N	1	"
7420N	2	"
7425N	1	"
7474N	9	"
7485N	2	"
7486N	5	"
74107N	2	"
74S138N	2	"
74S153N	11	"
74S157N	4	"
74S161N	6	"
74S166N	4	"
74S174N	4	"
74S175N	1	"
74S189N	4	64 bits Bipolar RAM
74S201N	4	256 bits Bipolar RAM
74LS245N	1	Transistor Logic
74LS253N	4	"
74259N	2	"
74283N	1	"
74S288N	1	256 bits Bipolar ROM
74S288	1	Transistor Logic
74LS373N	2	"
2116	8	Nch MOS 16K bits Dynamic RAM
2708	1	Nch MOS 8K bits EPROM

Item No.	Q'ty	Description
2716	8	Nch MOS 16K bits EPROM
Z80	1	Nch MOS CPU
NE556	1	Transistor Logic

[2] Other Semiconductor Devices

Item No.	Q'ty	Description
10D1	4	Diode

[3] Capacitors

Rating	Q'ty	Description
100PF/12V	1	Ceramic Capacitor
150PF/12V	1	"
0.1μF/12V	55	"
1μF/50V	1	Chemical Capacitor
10μF/16V	2	"
100μF/25V	4	"

[4] Resistors

Rating	Q'ty	Description
MS1028AM	3	1KΩ Resistor Array
10Ω 1/4W	3	Carbon Solid Resistor
47Ω "	3	"
270Ω "	3	"
330Ω "	1	"
510Ω "	2	"
1KΩ "	8	"
4.7KΩ "	1	"
47KΩ "	2	"

[5] Misc

Name	Q'ty	Description
Dip SW	1	8 Elements Switch Array
X'-tal	1	10.816MHz

b) Sub-circuit board IC location and parts list

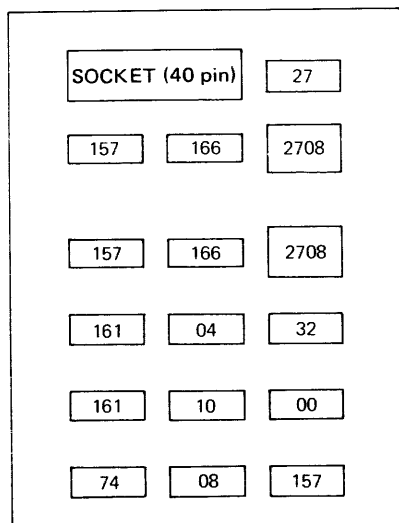

Fig. 16 Sub-circuit Board

[1] Integrated Circuit

Item No.	Q'ty	Description
7400N	1	Transistor Logic
7404N	1	"
7408N	1	"
7410N	1	"
7427N	1	"
7432N	1	"
7474N	1	"
74157N	3	"
74161N	2	"
74166N	2	"
2708	2	Nch MOS 8k bits EPROM

[2] Capacitors

Rating	Q'ty	Description
0.1m/12V	13	Chemical Capacitor

c) Sound circuit board IC location and parts list

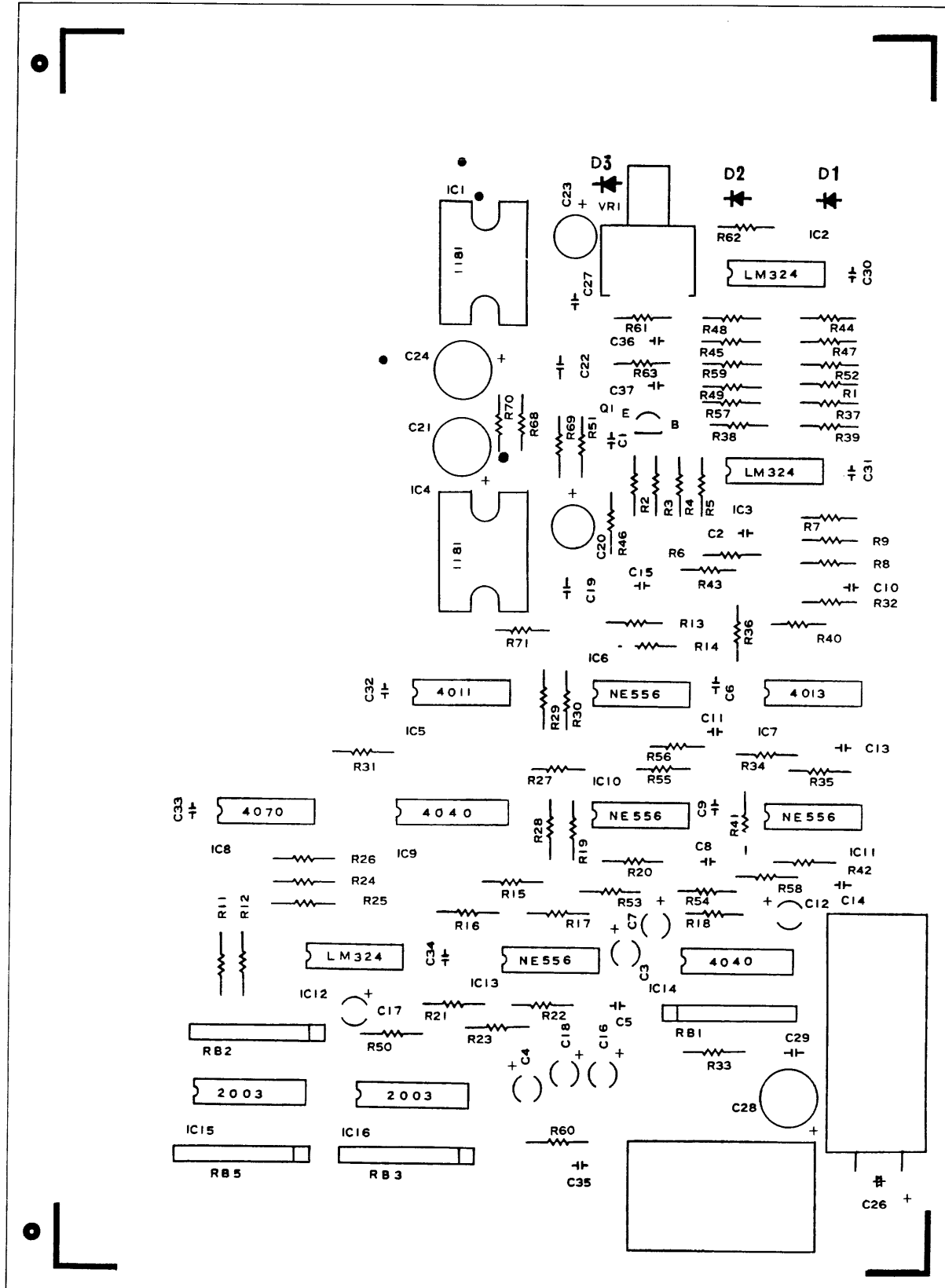

Fig. 17 Sound Circuit Board

SOUND BOARD PARTS LIST

Location	Rating	Description
R1	1M	Carbon solid resistor
2	1K	"
3	100K	"
4	1K	"
5	100K	"
6	1K	"
7	1M	"
8	10K	"
9	10K	"
11	100K	"
12	51K	"
13	1K	"
14	470K	"
15	1K	"
16	1k	"
17	75K	"
18	51K	"
19	1K	"
20	100K	"
21	1K	"
22	200K	"
23	1K	"
24	51K	"
25	100K	"
26	51K	"
27	1K	"
28	100K	"
29	1K	"
30	75K	"
31	1K	"
32	1M	"
33	330K	"
34	1K	"
35	200K	"
36	100K	"
37	100K	"
38	10K	"
39	10K	"
40	200K	"
41	1K	"
42	100K	"
43	10K	"
44	470K	"
45	100K	"
46	470K	"
47	470K	"
48	1M	"
49	100K	"
50	10K	"
51	470K	"
52	470K	"
53	470K	"
54	200K	"
55	200K	"
56	470K	"
57	100K	"
58	200K	"
59	100K	"
60	100K	"
61	100K	"
63	10K	"
68	1.5Ω	"
69	2.2K	"
70	4.7Ω	"
71	1.5Ω	"

Location	Rating	Description
VR1	RV16YP	1KΩ(B) Variable Resistor
RB1	MS1038AM	10KM Resistor Arroy
2	MS1028AM	1KΩ "
3	MS1038AM	10KΩ "
5	MS1038AM	10KΩ "

Location	Rating	Description
C1	0.1μ	Ceramic
2	0.1μ	"
3	1μ	Electrolytic
4	10μ	"
5	0.01μ	Ceramic
6	0.1μ	"
7	1μ	Electrolytic
8	0.1μ	Ceramic
9	0.001μ	"
10	0.1μ	"
11	0.01μ	"
12	1μ	Electrolytic
13	0.01μ	Ceramic
14	0.01μ	"
15	0.1μ	"
16	2.2μ	Electrolytic
17	10μ	"
18	0.47μ	Tantalum
19	0.068μ	Mila
20	47μ	Electrolytic
21	100μ	"
22	0.068μ	Mila
23	47μ	Electrolytic
24	100μ	"
26	1000μ	"
27	0.1μ	Ceramic
28	100μ	Electrolytic
29	0.1μ	Ceramic
30	0.1μ	"
31	0.1μ	"
32	0.1μ	"
33	0.1μ	"
34	0.1μ	"

Location	Item No.	Description
IC1	μPC1181H	Power Amplifier
2	LM324N	Quadruple Operational Amplifiers
3	LM324N	"
4	μPC1151H	Power Amplifier
5	CD4011CN	Quad 2-input NAND Gate
6	NE556N	Dual Timer
7	CD4013CN	Dual D Frip Flop
8	CD4070CN	Quad 2-input E-OR Gate
9	CD4040CN	14-Stage Binary Counter
10	NE556N	Dual Timer
11	NE556N	"
12	LM324N	Quadruple Operational Amplifiers
13	NE556N	Dual Timer
14	CD4040N	14-Stage Binary Counter
15	ULN2003AN	Darlington Transistor Array
16	ULN2003AN	"
Q1	2SC945	N-P-N Transistor
D1	10D1	Diode
2	"	"
3	"	"

CONTROL STICK PARTS LIST

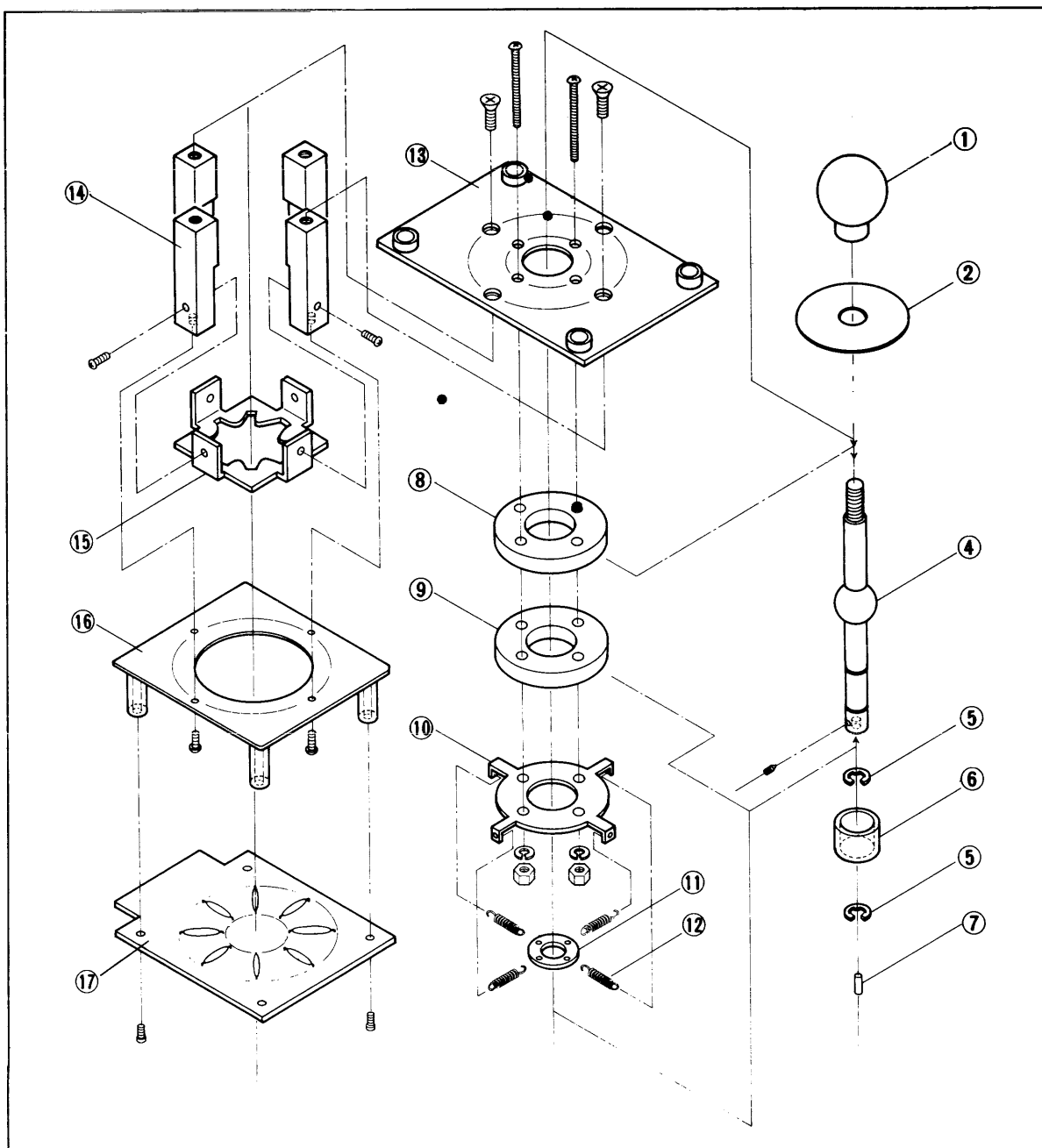

Ref. No.	Name	Ref. No.	Name
1	Knob. 24 or 32 Dim.	10	Spring hook
2	Resin board	11	Spring fixture
3		12	Spring
4	Lever shaft	13	Mounting base
5	E-ring	14	Support
6	Collar	15	Stopper
7	Magnet	16	Base
8	Bearing	17	Reed SW circuit board
9	Bearing		

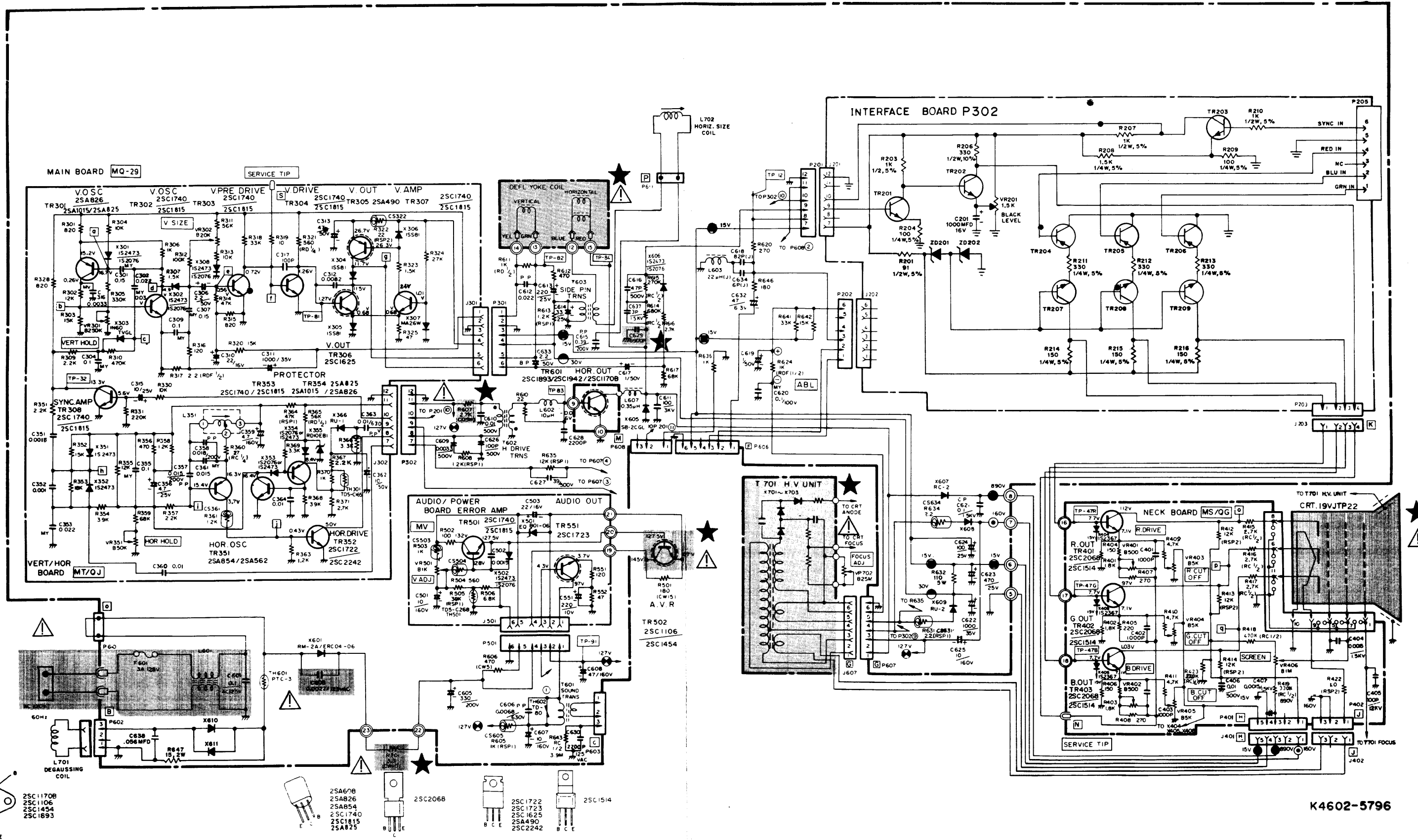

K4602-5796

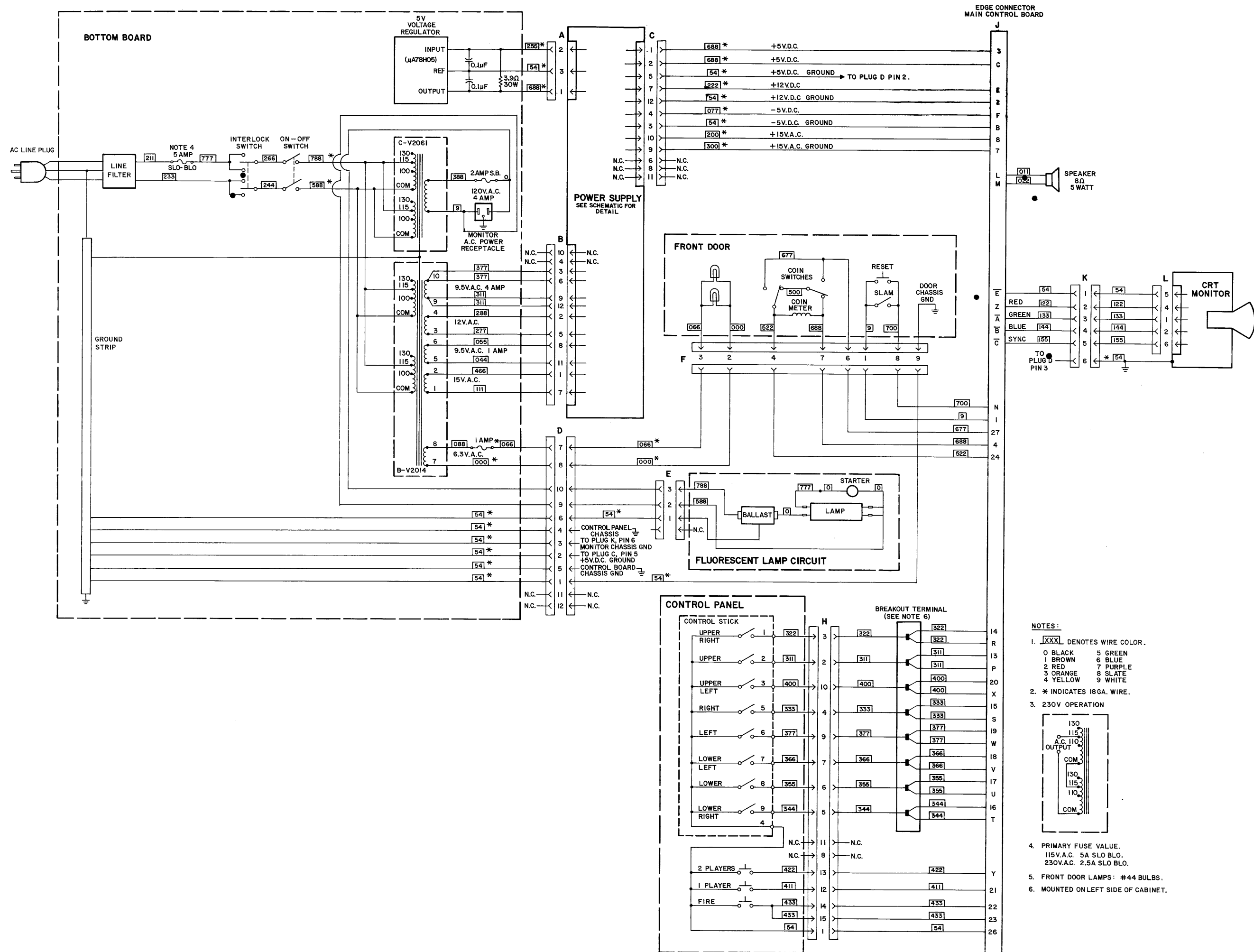

ENGINEERED BY UNIVERSAL CO., LTD.