

SLITHER

OWNER-OPERATOR SERVICE MANUAL

5945 North Rogers Ave.
Chicago, Illinois 60646
(312) 286-6722

16A-20968

CONTENTS

	Page
Component location	1
Game set-up and adjustments	2
Color monitor setup instructions	6
Self test mode	7
Theory of operation	11
Troubleshooting	18
Additional troubleshooting information	22
Power requirements	25
Video board component layout	26
Video board parts list	27
DSR board component layout	32
DSR board parts list	33
Schematics	39
Cabinet Wiring	40
Video CPU Board	41
Data/Sound/ROM Board (DSR Board)	43
Power Supply	45
Monitor (Wells-Gardner 19K 4951)	46

COMPONENT LOCATION

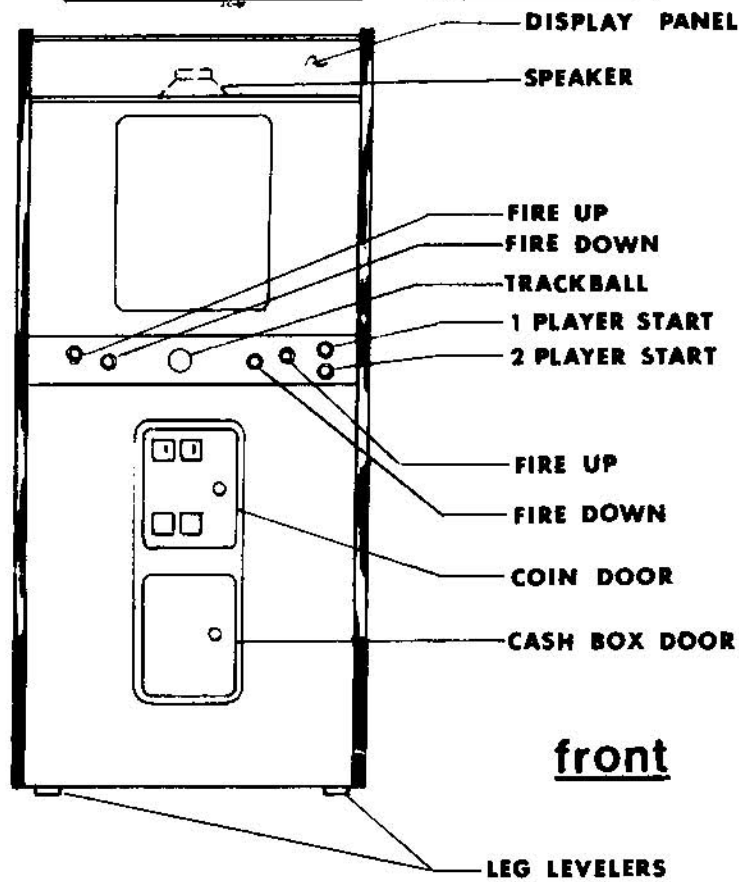

lower rear

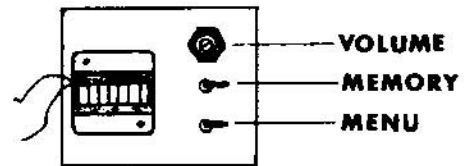
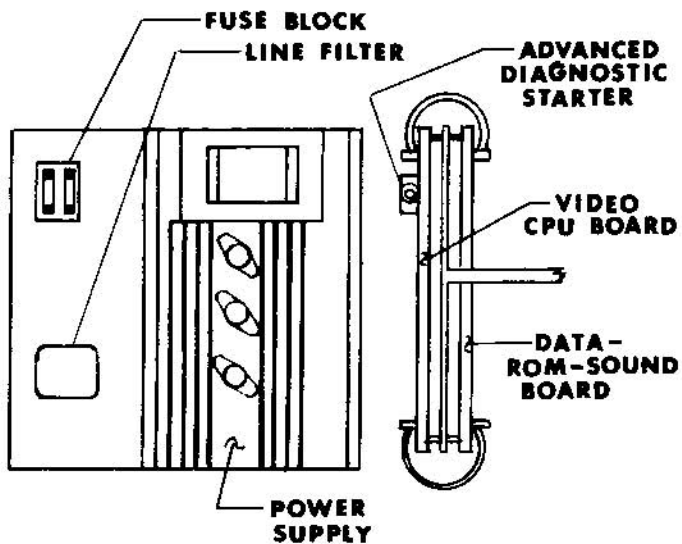

inside coin door

GAME SET-UP & ADJUSTMENTS

MEMORY PROTECT SWITCH

The Memory Protect Switch is used to prevent erroneous writes to locations in the CMOS RAM which store the location program variables selected from the LOCATION PROGRAMMING MENU. After any changes are made to this menu on the screen, it is necessary to hold the MEMORY PROTECT BUTTON while at the same time depressing the 2 PLAYER SELECT BUTTON in order to save screen changes and load them into CMOS RAM. (See Location Programming below.)

MENU BUTTON

To gain access to the various location and self test programming menus, the game is supplied with a Menu Button located inside the coin door. Activation of this button while the game is in the attract mode will place the operator in the AUDIT DISPLAY. From there, the player controls are used to advance to the next menu and to make any changes. Instructions on the screen show how this is done.

VOLUME CONTROL SETTING

A Volume Control for the game is located inside the coin door for quick volume adjustment within a limited range. The master volume control is located on the DSR logic board.

COIN METER

A 12 volt DC coin meter is located inside the coin door and is used to keep a count of all coins in the cash box. This meter is pulsed once for each coin in regardless of the coin chute used.

AUDIT DISPLAY

Push the menu button located inside the coin door one time with the game in the attract mode to display the audit menu. The audit display should look like this:

AUDIT DISPLAY

TOTAL GAMES PLAYED	XXX	(cannot be reset, default 0)
GAMES PLAYED	0	(resetable to 0, default 0)
MINUTES PLAYED	0	(resetable to 0, default 0)
BONUSES AWARDED	0	(resetable to 0, default 0)
CENTER COIN SLOT	0	(resetable to 0, default 0)
RIGHT COIN SLOT	0	(resetable to 0, default 0)
LEFT COIN SLOT	0	(resetable to 0, default 0)
USE FIRE UP FOR NEXT MENU		(To Location Programming)
USE PLAYER 1 TO CLEAR AUDITS		(reset above to zero)
USE PLAYER 2 TO CLEAR SCORES		(reset HIGH SCORES)
USER FIRE DOWN TO EXIT		(return to attract mode)

The default values given are entered when the CMOS RAM has failed to retain data. This may happen if the logic boards are removed from the machine, or the NI-CAD battery has been discharged. Charging of the NI-CAD battery is automatic if the game is left on, but the battery may become discharged if the game is left off for more than about 6 days. If this is the case the game will come up with the message "CMOS Invalid Requires Service" when first turned on. If the game comes up in the normal attract mode, CMOS RAM data is okay. See location programming below. IT IS NOT NECESSARY TO HOLD THE MEMORY PROTECT SWITCH WHEN RESETTNG THE HIGH SCORES OR THE AUDIT TOTALS. Actuate the memory protect switch to go from the service message to the location programming menu.

LOCATION PROGRAMMING MENU

From the AUDIT DISPLAY hit the FIRE UP BUTTON to access the LOCATION PROGRAMMING MENU. If the game displays the CMOS invalid message after it is first turned on, the data held in the CMOS RAM has been lost. (See above.) If this is the case, the game must be reprogrammed either with operator selected values or with the default values. If the game comes up in the normal attract mode when first turned on the previously saved values are valid. The player controls are used to change the values on the screen and to recall the factory default settings if desired. IMPORTANT ---- CHANGES MADE TO THE SCREEN VALUES ARE NOT LOADED INTO CMOS MEMORY UNLESS THE MEMORY PROTECT SWITCH IS HELD WHILE AT THE SAME TIME THE PLAYER 2 BUTTON IS PRESSED. HOLD THE MEMORY PROTECT SWITCH LONG ENOUGH FOR THE GAME TO RETURN TO ATTRACT MODE. Failure to exit the location programming menu in this manner will cause no changes in values even though changes have been made to the values on the screen.

The location programming menu should look like this:

LOCATION PROGRAMMING MENU

USE FIRE DOWN TO ADVANCE ITEM		(move cursor)
USE FIRE UP TO EXIT		(return to attract with NO changes)
USE TRACKBALL TO SELECT VALUE		(move ball up or down)
USE PLAYER 1 TO RECALL DEFAULTS		(load default values onto screen only)
USE PLAYER 2 TO SAVE UPDATES		(don't forget the MEMORY PROTECT SWITCH!)
BONUS LEVEL	000XX0000	(10 to 25,000 in 5000 increments, default is 15000)
PLAYS PER GAME	03	(shooters to start 1 to 9, default 3)
DIFFICULTY	03	(1 to 3, default 1)
FREE PLAY	N	(N or Y, default N (No))
CENTER COIN MULTIPLIER	04	(0 to 99 coin units per coin, default 4)
RIGHT COIN MULTIPLIER	01	(0 to 99 coin units per coin, default 1)
LEFT COIN MULTIPLIER	01	(0 to 99 coin units per coin, default 1)
COIN UNITS CREDITS	01	(0 to 99 coin units for credit, default 1)
COIN UNITS BONUS	00	(0 to 99 bonus credit level, default 0)
CREDITS COIN LOCK	10	(0 to 99 credits to de-engerize coin lockout coils (optional), default 10)
COCKTAIL OPTION	N	(N for upright or Y for cocktail, default N)

In order to leave the LOCATION PROGRAMMING MENU without making any changes hit the FIRE UP BUTTON. This will return the game to the attract mode. In order to leave the LOCATION PROGRAMMING MENU and load the factory default values first hit the PLAYER 1 BUTTON to load the defaults to the screen and then hold the MEMORY PROTECT SWITCH and press the PLAYER 2 BUTTON. Be sure to hold the memory protect switch long enough for the game to return to the attract mode.

++++ THE DEFAULT PRICING IS 1 PLAY PER COIN +++++

BONUS LEVEL - This is the score level at which extra shooters are awarded. The default level is 15,000 points. This level may be adjusted from 10 to 25 thousand in 5 thousand point increments. Extra shooters are awarded at all even multiples of this value. For example, if this value is set to 15,000 then bonus shooters are awarded at 15,000, 30,000, 45,000, 60,000 etc., etc. points.

PLAYS PER GAME - This is the number of shooters given at the start of the game. The default value is 3 shooters. This value may be adjusted from 1 to 9

DIFFICULTY - The difficulty setting changes the game in a subtle manner to make the game easier or more difficult to play. The default setting is 1. This adjustment can be in the range of 1 to 3, with 1 the easiest and 3 the hardest.

FREE PLAY - The free play mode is primarily intended for use in showrooms and at conventions or for home use. The default is N for no or normal pricing. Set to Y for yes and free play if desired. Setting the game to free play does not affect the attract mode.

CENTER COIN MULTIPLIER, RIGHT COIN MULTIPLIER AND LEFT COIN MULTIPLIER - Each of the coin multipliers are set up to multiply the number of coins dropped into the appropriate coin slot by a fixed value to award COIN UNITS. One coin in would equal some number of coin units. Credits needed to play the game are awarded when some number of coin units has been reached as defined in the following two adjustments. The default values are center 4, left 1, right 1. The center coin chute is not available on the coin door supplied and is not wired. Any of the three multipliers may be set anywhere from 0 to 99 coin units per coin in.

COIN UNITS PER PLAY - This value is the number of coin units necessary to award one credit. The coin unit total is not displayed at any time and is reset to zero at the start of play. The credit total is displayed and is decremented by one for each player at the start of a game. The default value is 1 and this may be set from 0 to 99.

COIN UNITS PER BONUS - This is the level of coin units at which a bonus or extra credit is awarded. It is used when incentive pricing is desired such as 1 play for 25¢ and 3 plays for 2x 25¢. Reaching the bonus level

resets the coin unit total to zero so that working toward the next bonus starts over. The default level is 0 (no bonus) and this may be adjusted to any value from 0 to 99. If this all is a bit confusing, the following tables for various pricing schemes will be of value. The tables show settings for three coin chutes, even though the center chute is not provided on the coin door.

	PRICING DESIRED	LEFT COIN MULTIPLIER	CENTER COIN MULTIPLIER	RIGHT COIN MULTIPLIER	COIN UNITS FOR CREDIT	COIN UNITS FOR BONUS
DEFAULT USA	1/25¢, 4/\$1	01	04	01	01	00
USA	1/50¢, 3/\$1, 6/\$2	01	04	01	02	04
	1/50¢	01	04	01	02	00
FORIEGN						
1DM, 5DM door	1/1DM, 6/5DM	06	00	01	01	00
1 FRANC, 5 FRANC door	1/2F, 3/5F only	01	16	06	02	00
25 cents, 1 Guilder door	1/25, 4/1G	01	00	04	01	00
5 FRANCS, 10 FRANCS	1/5F, 2/10F	01	00	02	01	00
5 FRANCS, 10 FRANCS	1/10F	01	00	02	02	00
1 UNIT, 5 UNITS	1/2, 3/5	01	00	06	02	00
TWIN COIN	1/1 coin	01	00	01	01	00
TWIN COIN	1/2 coins	01	00	01	02	00

CREDITS COIN LOCK- Sets the level of credits at which time the optional coin lockout coils are de-energized and further insertion of coins is prohibited. The setting of CREDITS COIN LOCK does not affect the operation of the coin switches or other pricing. The default value is 10 and may be set in the range of 0 to 99. Coin lockout coils are not standard equipment on the coin door and the wiring in the cable harness is not provided. Coin lockout coils and the necessary wiring may be added in the field if necessary.

COCKTAIL OPTION- The default value is N for the upright game, and may be changed to Y for the cocktail version. The cocktail version flips the picture for player 2 and expects a second set of player controls.

COLOR MONITOR SETUP INSTRUCTIONS

69X1179-100

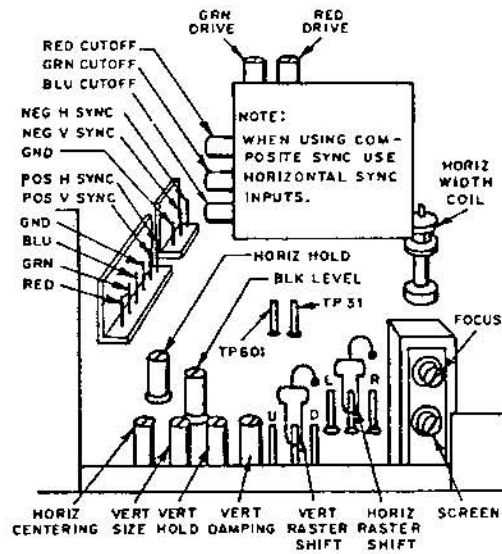

K4901	K4952
K4902	K4956
K4906	K4956R
K4911	K4961
K4951	

1. HORIZONTAL FREQUENCY

With the monitor being driven from the game signal, connect a jumper between TP601 and TP31. Adjust the horizontal hold control until picture stops sliding horizontally, remove jumper. Do not use the horizontal hold control for horizontal centering. (See #3) NOTE: When game sync is composite, use horizontal sync input.

2. PICTURE SIZE

Adjust the vertical size control, and the horizontal width coil for desired picture size.

3. PICTURE CENTERING

If the video is off center vertically, move the vert raster position adjustment to the up or down position. If the video is off center horizontally, adjust the horizontal video position control to center the picture. If any additional horizontal positioning is required, move horizontal raster position adjustment to the left or right position.

4. VERTICAL DAMPING

Adjustment of this control is required only if the monitor is being used with a game in which the top several raster lines are visible on the screen. Adjust the vertical damping control for uniform spacing of the top raster lines.

5. BLACK LEVEL

Adjust the black level control to obtain the proper black level (the black portion of the picture just extinguished). Do not use the screen control to set the black level.

6. FOCUS

Adjust the focus control for best overall definition and fine picture detail.

SELF TEST MODE

To enter the Self Test Mode, press the Self Test Button located on the Video PCB near the LED display. All the LED's should blink on and the Hardware Tests should start. If at anytime during the hardware tests the machine halts for more than ten seconds, there has been a detected failure. A brief description of a few tests and probable chip failures are contained in the following section (Hardware Tests), but for more extensive repair, refer to the Troubleshooting Guide found elsewhere in this manual.

HARDWARE TESTS

1. Video Board ROM Checksum

The ROM Checksum calculates the checksum of each Video ROM and compares it to the checksum stored for that ROM. If it differs from the stored value, the machine will halt and the value of the LED s can be referenced to the faulty ROM by the following table.

VIDEO BOARD ROM CHECKSUM			
LED	VIDEO		
VALUE	ADDRESS	2716	2732
01 0000	A000-A7FF	N/A	U41
01 0001	A800-AFFF	N/A	U41
01 0010	B000 B7FF	N/A	U40
01 0011	B800-BFFF	N/A	U40
01 0100	C000-C7FF	U43	U39
01 0101	C800-CFFF	U42	U39
01 0110	D000-D7FF	U41	U38
01 0111	D800-DFFF	U40	U38
01 1000	E000-E7FF	U39	U37
01 1001	E800-EFFF	U38	U37
01 1010	F000-F7FF	U37	U36
01 1011	F800-FFFF	U36	U36

The EPROM Memory in a given game may be implemented as banks of either 2716 or 2732 EPROMS. The EPROM type for the video bank is selected by the decoding jumper (JUMP PLUG 1).

2. Communications RAM from Video Board

The Communications RAM test determines the stability of memory shared by the two processors by storing a predefined series of numbers throughout the RAM, then reading it back to insure that it was stored correctly.

Failure Code 00 0010

3. Video Board CMOS RAM

After saving values in another portion of memory, the CMOS RAM is tested in the same manner as the Communications RAM. If the CMOS RAM passes the test, all of the locations are restored to their previous values.

Failure Code 00 0011

4. Video Board Color RAM

This tests the system Color RAM by storing predefined sequences of numbers in the Color RAM, then reading them back while testing for accuracy.

Failure Code 00 0100

5. Video Board Screen RAM

The Screen RAM is tested by writing a pattern to each page on the screen. The results of these writes is then compared to the original pattern. Any discrepancy causes the machine to halt with the LED displaying the faulty RAM. Refer to the following table for decoding the LED patterns.

VIDEO BOARD SCREEN RAM			
LED	RAM	LED	RAM
VALUE		VALUE	
10 0000	U33	11 0000	U66
10 0001	U32	11 0001	U65
10 0010	U31	11 0010	U64
10 0011	U30	11 0011	U63
10 0100	U29	11 0100	U62
10 0101	U28	11 0101	U61
10 0110	U27	11 0110	U60
10 0111	U26	11 0111	U59
10 1000	U17	11 1000	U48
10 1001	U16	11 1001	U47
10 1010	U15	11 1010	U46
10 1011	U14	11 1011	U45
10 1100	U13	11 1100	U44
10 1101	U12	11 1101	U43
10 1110	U11	11 1110	U42
10 1111	U10	11 1111	U41

6. DSR Board ROM Checksum

The ROM Checksum calculates the checksum of each Data ROM and compares it to the checksum stored for that ROM. If it differs from the stored value, the machine will halt and the value of the LED's can be referenced to the faulty ROM by the following table.

DATA BOARD ROM CHECKSUM			
LED	DATA		
VALUE	ADDRESS	2716	2732
01 0000	A000-A7FF	N/A	U32
01 0001	A800-AFFF	N/A	U32
01 0010	B000-B7FF	N/A	U31
01 0011	B800-BFFF	N/A	U31
01 0100	C000-C7FF	U34	U30
01 0101	C800-CFFF	U33	U30
01 0110	D000-D7FF	U32	U29
01 0111	D800-DFFF	U31	U29
01 1000	E000-E7FF	U30	U28
01 1001	E800-EFFF	U29	U28
01 1010	F000-F7FF	U28	U27
01 1011	F800-FFFF	U27	U27

The EPROM Memory in a given game may be implemented as banks of either 2716 or 2732 EPROMS. The EPROM type for the Data bank is selected by the decoding jumper (JUMP PLUG 2).

7. DSR Board Local Memory

The Data Processor uses a known sequence of numbers to test the bits in Local Memory. If a bad bit is found the machine will halt with the following display.

Failure Code 00 0111

8. Communications RAM Addressing

The function of this test is to insure that both the Data and the Video Processors address the Communications RAM in the same manner. The Data Processor requests the Video Processor compare the results to the expected pattern. If it does not match, one of the processors is probably decoding the address incorrectly as the RAM itself was previously tested for stability by the Video Processor. The machine will halt with the following display if a failure is detected.

Failure Code 00 1000

9. Data/Video Handshake

This test insures that the Data Processor can send priority commands via interrupts to the Video Processor. The Video Processor is halted, then restarted by the Data Processor after the proper command acknowledgements are received. If a failure occurs, the machine will halt with the following display.

Failure Code 00 1001

During the later portion of the tests the video screen should show some nice pretty colors and finally end up with vertical color bars on the screen. At this time several other tests and displays can be accessed using the FIRE UP BUTTON and the FIRE DOWN BUTTON at the appropriate places. From the color bars press FIRE UP to get to the monitor display subtests.

MONITOR DISPLAY SUBTESTS

GRID- From the color bar display press FIRE UP to get to the first of the monitor subtests, the grid. The grid is drawn in red and then changed to white. From this point press FIRE UP to skip to the I/O TEST or press FIRE DOWN to go to the next monitor subtest. Proceed from one monitor subtest to the next by pressing FIRE DOWN. The monitor display subtests are as follows: WHITE GRID, WHITE DOTS, BLUE DOTS, GREEN DOTS, RED DOTS, ALL WHITE, ALL BLACK.

FULL COLOR DISPLAY

From the monitor display subtests press FIRE UP to display all possible colors on the screen.

I/O TEST

From the full color display press FIRE UP to proceed to the I/O test. Switch, trackball, and sounds can be tested from this menu. The screen should look something like this:

PIA REG TRACKBALL SOUND TEST					
PRESS FIRE UP FOR NEXT MENU				(proceed to the audit display)	
PRESS FIRE DOWN NEXT SOUND				(advance sounds from 0 (silent) to A)	
CURRENT SOUND TEST 0				(current sound being excited 0 to A)	
9000	FF	4	F	37	(PIA at \$9000 - player switches)
9400	FF	4	FF	4	(PIA at \$9400 - player and coin switches)
9800	aa	4	BF	26	(aa is trackball vert pos. BF sound command)
9C00	bb	4	9F	26	(bb is trackball horiz pos. 9F for sounds)

Please note that all of the switches and the trackball should make some change in the above display. Trackball coordinates of 0,0 should put the shooter in the lower left corner of the screen. Make sure that slight movements of the trackball cause the vertical and horizontal position numbers to change one at a time from 00 to FF hex.

Pressing the FIRE UP BUTTON will exit the self tests and place the game in the AUDIT DISPLAY as described in the SET UP & ADJUSTMENTS section of the manual.

THEORY OF OPERATION

1.1 GENERAL

The Century II video game system is a dual multi-processor based system utilizing the Motorola 6809E.

The system consists of two PC Boards. The Video Board and Data/Sound/Rom (DSR) Board.

- A. The Video Board performs all screen display functions, such as play field, line drawing, etc.
- B. The DSR Board performs the following functions.
 - 1. Contains all necessary ROMs for both video and data processors.
 - 2. Generates sounds
 - 3. Contains the data processor which supervises overall operation of the game system.

In order to facilitate inter-processor communication, the data and video micro-processor are running synchronously using clock and timing signals developed on the video board. For this reason, discussion will begin by examining the video board.

2.1 SYSTEM CLOCK

The fundamental system clock is generated by the 21.5 MHz crystal and inverters U24 and U39. This 21.5 MHz signal is divided by high speed flip flop U38 to obtain a 10.75 MHz main clock with a precise 50 percent duty cycle.

This 10.75 MHz signal generates all other fundamental timing signals for the system, including the data processor. IC U23 divides the 10.75 MHz signal down to 5.375 MHz, 2.6875 MHz, 1.34375 MHz, and CCLK. IC's U9, U37, and U38 combine these signals, presenting them to U25, which synchronizes the output signal to the system 10.75 MHz clock.

The performance characteristics of the clock circuits may be noted by referring to timing diagram 1. All signals conform to the limits stated in these diagrams.

2.2 SCREEN RAM

The video processor controls a screen ram of 256 x 256 pixels, with 8 bits per pixel. In order to enable access to this information, the screen is divided into two pages, top and bottom, chosen under software control. These pages are both addressed at 7FFF_H with address 0 corresponding to the upper left corner of the screen when horizontally oriented. All CRT accesses to this RAM are transparent to the processor and may be read or written at any time.

THEORY OF OPERATION

SCREEN RAM (continued)

The timing of the screen RAM and the eventual scan is controlled by a Motorola 6845 CRT controller chip. Its address outputs are gated by U19, U20, U50, and U51 for inversion, when in cocktail table mode. The scan addresses are multiplexed by U35, U52, U53, and U54 with the addresses present on the microprocessor data bus for standard RAS-CAS accessing. The desired bank memory is addressed by U89, one of four decoder.

Data written into the screen RAM comes directly from the system bus, buffered by 33 ohm resistors. If a processor read is taking place, the data is placed on the data bus by U77, U78, U79, and U80. The first screen read is latched by the 74LS374's, U96, U95, U93, and U94. A second screen read is then performed, and this data, together with the data from the first read and latched by the 374's, is presented to the 8 74LS299 shift registers. These registers may be shifted in either direction for cocktail table implementation. The byte stream then proceeds to the color RAM.

2.3 MEMORY MAP

Eight address blocks of 1K bytes are provided for accessing other devices. These blocks are organized as follows:

- | | | |
|----|-------------------|---------------------------------------|
| A. | 8000 _H | Dual port RAM |
| B. | 8400 _H | CMOS battery backup memory |
| C. | 8800 _H | LED output and color RAM page select |
| D. | 8C00 _H | Data FIRQ activation address |
| | 8C01 _H | Video FIRQ de-activation address |
| E. | 9000 _H | Color RAM |
| F. | 9400 _H | Address latch indexed screen location |
| | 9401 _H | Write mask for CAS |
| | 9402 _H | Address latch Hi-byte |
| | 9403 _H | Address latch low byte |
| G. | 9800 _H | Scan line readback location |
| H. | 9C00 _H | CRT controller base address |

2.4 DUAL PORT RAM

The inter-processor communication memory is the heart of the multi-processor system. This RAM may be accessed in its entirety by either processor. Access is arbitrated as follows:

1. The data processor runs in quadrature with (one quarter clock cycle ahead of) the video processor. In other words, E is inverted for use as DQ, and Q becomes DE. Refer to timing diagram 2.

THEORY OF OPERATION

2.4 DUAL PORT RAM (continued)

2. The data processor, by nature of this timing, accesses the dual port RAM $\frac{1}{4}$ cycle before the video processor. At this point the video processor access is flagged by U36, which causes a cycle to be skipped from the video processor's main clocks, VQ and VE.
3. The video processor is unable to access the dual port RAM unless the data processor is not accessing it, as it will not be receiving clocks during that time.

The cycle steal is accomplished through the generation of signal DPMUX by U36. This signal directly steals the cycle, and also folds over muxes U5, U6, and U21, switching the address lines, R/W and gating signals. U1 and U2 gate the data to or from the desired processor. U22 insures that no spurious writes are generated during foldover.

2.5 CMOS RAM

The CMOS RAM is implemented for use as both a battery backed-up storage area and a work area for the video processor. The gating of U100, U101, U102, and U103 insure that writes to the block of RAM from 9700 - 87FF_H cannot be performed unless the memory protect switch is held (J19-2 grounded). When turned off supply current for U85, U86, and U100 is provided by this battery. U100 gates the MRST signal and prevents invalid operations during power up and down.

2.6 LED OUTPUT AND COLOR RAM PAGE SELECT

Address 8880_H is simply a latch, U72. The upper six bits drive LEDs on the circuit board for diagnostic or other communication which, for some reason, cannot be done through the screen. The LEDs have been scrambled during PC layout, and their bit configuration is:

7 5 6 4 2 3

with bit 7 being closest to the edge of the circuit board. Bits 0 and 1 go to the color RAM and will be discussed later.

2.7 BIDIRECTIONAL FIRQ CAPABILITY

To provide for immediate interprocessor communication on demand, a bi-directional FIRQ capability has been provided. Any access of 8000_H will generate a FIRQ to the data processor. Any access of 8001_H will clear a FIRQ

THEORY OF OPERATION

2.7 BI-DIRECTIONAL FIRQ CAPABILITY (continued)

generated by the data processor to the video processor. This is accomplished by U7, U8, and U9.

2.8 COLOR RAM

The color RAM is used as a translation matrix so that a number of different pixel values may access a given color, or to change the color of a given area of the screen without re-writing the screen RAM. The serial bit stream, eight bits wide, comes from the shift registers of the screen RAM to be presented to muxes U55, U73, and U74. These select between the video processor bus and the serial bit stream. As processor access times are considerably greater than the basic time (200 ns), it is necessary to access this register only during retrace times. Bus read/write occurs through U75, and serial output is latched U76. This data stream is converted to a color pallet of 64 colors and four intensities.

When the serial stream is selected for access, the two high order bits are provided by the LED output latch. This allows the program to select between four pages of color RAM rapidly.

2.9 ADDRESS LATCH CIRCUITRY

Two methods of addressing the screen memory have been provided to ease accessing of the dual page screen map.

METHOD 1: Write the desired address (16 bits) into 9402_H and 9403_H. This location may now be read or written at location 9460_H.

METHOD 2: Write the desired high order address bit into bit 7 of 9402_H. This might even be done by storing the address (16 bits) as though using Method 1. Then strip the high order bit from the address, and use it as an index. As long as you stay within this page, the latch need not be re-written.

U36, U70, and U71 latch the address. U36 is used in conjunction with U70 as U70 and U71 are tri-stated when inactive. The screen address is driven on the DA bus by U84 and U98 for processor bus accesses, and by U70 and U71 for latched address accesses. Decoding is performed by U87 and U88.

2.10 SCAN LINE READBACK

When read, this location is the number of the scan line currently being drawn by the beam. U34 latches the last row address drawn, and U101 prevents erratic updating at the end of a horizontal line. There are 256 valid scan lines 00-FF.

THEORY OF OPERATION

2.11 CRT CONTROLLER BASE LOCATION

The 6845/6545 is a software programmable sync and scan generator. It has two ports based at 9000. The user may consult Motorola, Hitachi, Rockwell, or Synertek documentation.

3.1 DATA/SOUND/ROM (DSR) BOARD

The DSR Board contains all necessary ROMs for both video and data processors. All clocks originate on the Video Processor Board as discussed before.

3.2 MEMORY MAP

The following devices are accessible to the data processor:

- A. 8000_H Dual port memory
- B. 8400_H Local Memory
- C. 8800_H Expansion Ram memory
- D. 8C00_H Video FIRQ activation address
- 8C01_H Data FIRQ deactivation address
- E. 9000_H Game play PIA U2
- F. 9400_H Game play PIA U1
- G. 9800_H Sound PIA 1 U10 and Track Ball
- H. 9C00_H Sound PIA 2 U9 and Track Ball

3.3 DUAL PORT MEMORY

See discussion of dual port memory under video processor heading (2.4).

3.4 LOCAL MEMORY

This is a 1K block of memory, U21 and U23 provided for scratch and work area for the Data Processor. If more memory is required, there is another 1K block available, U20 and U22.

3.5 BI-DIRECTIONAL FIRQ CAPABILITY

Any access of 8C00_H will generate a FIRQ to the Video Processor. Any access of 8C01_H will clear _H FIRQ generated by the Video Processor to the Data Processor. This is accomplished by U7, U8, and U9 on the Video Board.

THEORY OF OPERATION

3.6 GAME PIA's

Two 68A21's are provided for interfacing with Play Controls and Coin Door Switches. These are located on the DSR Board and are U1 and U2 which are accessed through connector J15, J16, and J17.

U1 and U2 interface through filter circuits for those lines dedicated to inputs. Three high current drivers are provided for coin door outputs.

3.7 SOUND AND TRACKBALL PIA's

U9 and U10 serve a dual purpose. The A side of each PIA serves as an input for trackball movement. U9 gives left/right movement information, while U10 gives vertical/horizontal information coming from trackball movement.

When the trackball is moved in any direction, a signal is produced by the trackball circuitry creating a quadrature signal which is sent to U3 (U4 is used for cocktail table use for player 2). Outputs of U3 are sent to U6-74LS157 then to U5. Half of U5 is used for up and down, the other for right and left movement signals. The signal then goes to U7 and U8 (both 74LS191) which are binary counters. The outputs are buffered through a PIA to the microprocessor. The data processor compares previous position with new movements to get final position of player.

The B side of each PIA serves as an output. All outputs of one PIA are sent to one SN76489AN which is a Digital Sound Generator. For more information on the SN76489AN see specifications supplied by Texas Instruments. To load the Sound Generator, CB 2 (Pin 19) must go low to inform the Sound Generator that information is ready. Once received, the sound generator loads data bits to appropriate control registers. The SN76489AN uses a 1.25 MHz clock. This chip requires approximately 32 clock cycles to load the data into the control registers. Once done, Pin 4 (ready) goes low to inform the microprocessor that all data was received and that it is ready for the next data byte. The final output signal (Pin 7) is then sent to the audio amplifier.

3.8 ROMS

Eight ROM locations are provided for the Data Processor, U27-U34. All sound instructions are contained within these ROM locations. These ROMs are selected by U24. There are eight ROM locations provided for the Video Processor, selected by U19.

ROM banks may consist of either 2716 or 2732 type EPROMS and are determined by a jumper plug. Jumper Plug 1 for Video, and Jumper Plug 2 for Data. The highest address EPROM is U34 and U27 respectively in each bank, with addresses progressing downward in 0800_H byte blocks for 2716's or 1000_H byte blocks for 2732's.

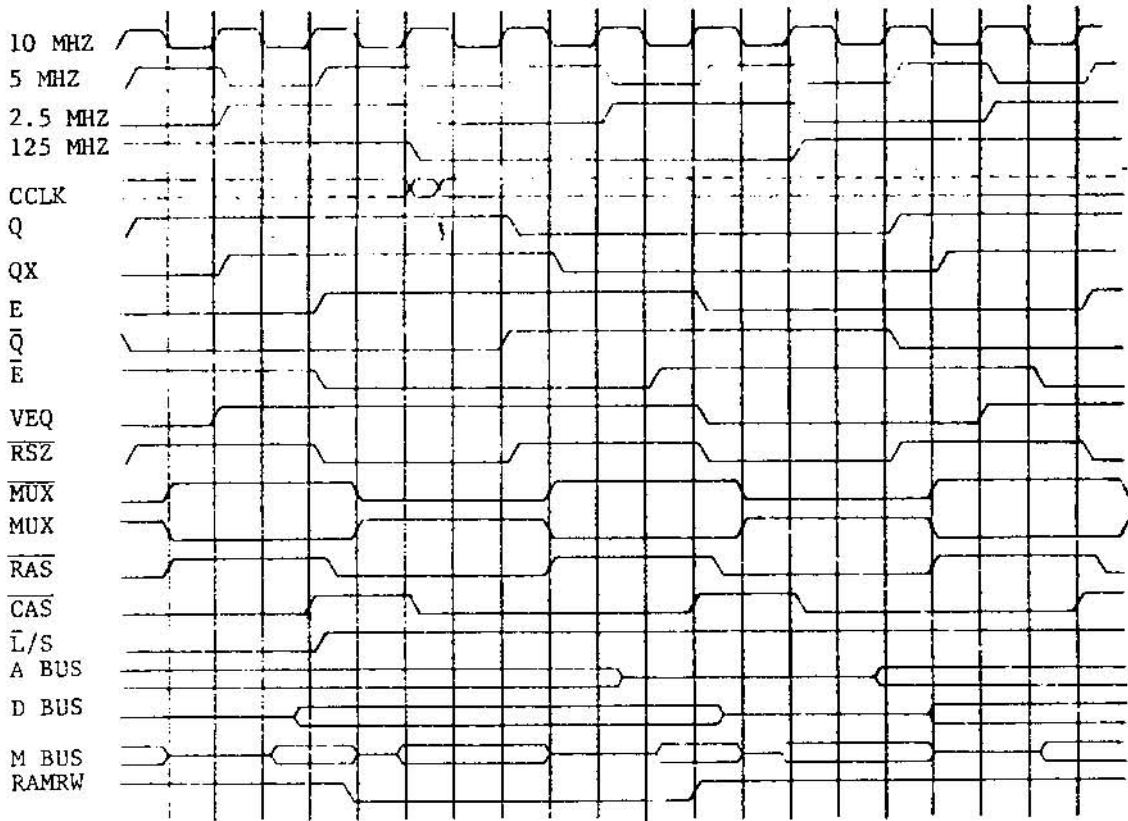

TIMING DIAGRAM 1 SYSTEM CLOCK

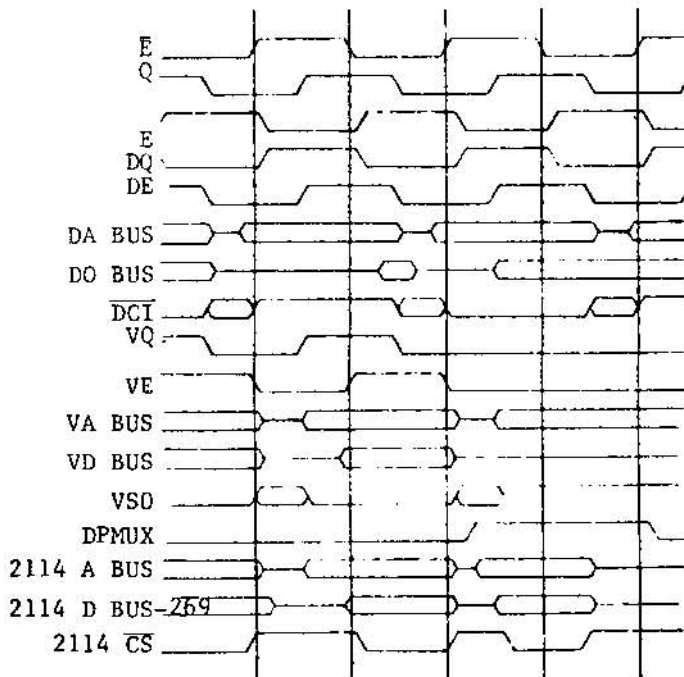

TIMING DIAGRAM 2 DUAL PORT RAM

**TROUBLESHOOTING
GUIDE**

TROUBLESHOOTING GUIDE

PROBLEM	PROBABLE SOLUTIONS
LED CODE 01 XXXX	<p>Refer to table labeled Video Board ROM Checksum and Data Board ROM Checksum. If problem is not solved, then replace U27 or U36 (these ROMs store all checksums).</p> <p>If problem is not solved, then check chip select times to locate faulty EPROM.</p>
LED CODE 00 0010	<p>Replace U3 and U4. If code still appears during system test, check U1, U2, U5, U6, U21, and U22 for proper signals.</p>
LED CODE 00 0011	<p>Replace U87, and U88. If code still appears during system test, check U102, U103, U104, U105, and associated circuitry for proper signals.</p>
LED CODE 10 XXXX	<p>Refer to Table labeled Video Board Screen RAM and replace RAM. If same code appears during system test, check output circuitry of that RAM.</p> <p>EXAMPLE: Code 11 1100 appears (U44), check U79, U95, and U98 for proper inputs.</p>
LED CODE 00 0111	<p>Replace U21 and U23. If code still appears during system test, check U14, U15, and U24 for proper signals.</p>
LED CODE 00 1000	<p>Replace U3 and U4. If code still appears during system test, check U1, U2 and U101 for proper signals.</p>
LED CODE 00 1001	<p>Check U7, U8, U9, U39 and check selects for proper signals.</p>
NO PICTURE	<p>Insure all connections are seated properly.</p> <p>Check J1 on both boards for proper voltages. If one or more voltages are missing disconnect J1 from each board and re-check voltages. If they are still missing, replace power supply. If they return, reconnect one board at a time to determine which board is bad and return it to the factory for repair (damage is probably extensive).</p> <p>Check J2 for signals if there are signals on all the lines (Pin 1, 9, 10, 11, 14), the monitor is probably bad.</p>

TROUBLESHOOTING GUIDE

PROBLEM	PROBABLE SOLUTIONS
NO PICTURE	<p>Push SW1 for system test, watch LEDs if 4 and 6 are lighted, system test is running. If LEDs 4 and 6 go off, the system test is completed. Check Q1 first, if okay, then check U76 and U91 for proper signals.</p> <p>If system tests fail there is probably a problem on the bus of one of the microprocessors. Troubleshooting now becomes quite complicated. Troubleshooting from this point should be performed by a competent computer technician or return to the factory for service. Refer to Troubleshooting procedure for troubleshooting bus problems.</p>
NO GAME MODE	Check U34, U1
DOTTED DISPLAY	Push SW1 for system test, if test passes go to either Gray Scale or Color Bar display and use troubleshooting procedure listed for each.
FOUR DISPLAYS	U18 is bad or input clocks are wrong frequency.
DISTORTED DISPLAY	Check Latch circuitry when RAM test fails.
DISPLAY JITTERS	Check clock circuitry for proper timing signals.
NO AUDIO	Check U9, U10, U17, U18 and volume control circuitry.
NO TRACKBALL MOVEMENTS	Insure trackball has power and outputs work.
NO UP OR DOWN TRACKBALL MOVEMENTS	Check U3, U4, U5, U6, U10, U11 and U12 for proper signals.
NO RIGHT OR LEFT TRACKBALL MOVEMENT	Check U3, U4, U5, U6, U7, U8 and U9 for proper signals.

TROUBLESHOOTING GUIDE

PROBLEM	PROBABLE SOLUTIONS
COIN COUNTER INOPERATIVE	Check U1 and associated coin door inputs for correct signals.
NO PLAYER CONTROL	Check U1 and associated Player One circuits for correct signals.

ADDITIONAL TROUBLESHOOTING INFORMATION

Troubleshooting Color Bars

This is how the bars are generated:

The CPU divides the screen RAM into 16 areas corresponding to 16 bars on the screen. Each area is written with a data value from the table below. Each data value exercises one bit in the screen RAM. The color RAM is written with a pattern which outputs each data value with a recognizable color from the table. All other data values are coded black. This results in a normal screen of 16 bars per the table.

BAR #	COLOR	SCREEN RAM CONTENT		BIT TESTED
		HEX	BINARY	
1	Red	01	0000 0001	CR0]
2	Orange	02	0000 0010	CR1]
3	Yellow	04	0000 0100	CR2] LEFT
4	Green	08	0000 1000	CR3] TOP
5	Blue Green	10	0001 0000	CR4] PAGE 0
6	Blue	20	0010 0000	CR5]
7	Violet	40	0100 0000	CR6]
8	White	80	1000 0000	CR7]
9	Red	FE	1111 1110	0]
10	Orange	FD	1111 1101	1]
11	Yellow	FB	1111 1011	2]
12	Green	F7	1111 0111	3] RIGHT
13	Blue Green	EF	1110 1111	4] BOTTOM
14	Blue	DF	1101 1111	5] PAGE 1
15	Violet	B7	1011 1111	6]
16	White	F7	0111 1111	7]
None	Black	XX	XXXX XXXX	

If the self test pass, errors in those circuits which affect CPU access are ruled out. This leaves latches U93, U96, shift registers U97, U98, and U107-111, direction select U113 and U106 and the CR side of the color RAM MUX U55, U73, and U74.

Stuck bits may be identified by observing abnormal bars. A bit stuck high will result in black bars (two big high) on the left or top half of the screen except for the bar associated with the stuck bit. On the right or bottom half the bar associated with the stuck bit will be black. The converse is true of a bit stuck low.

An error across the entire bar indicates an error in the shift registers, direction select, or color RAM MUX which affects every pixel. Lines of error running crosswise to the bars indicate an error in one bank of RAM if every fourth pixel, or in one of the output latches (U93-96) if every eighth pixel.

Additional Troubleshooting Information
Troubleshooting Color Bars

The following 299's control the following Color Bars:

<u>IC</u>	<u>COLOR BARS AFFECTED</u>
U97	6, 9, 10, 11, 12, 12, 15, 16
U98	5, 9, 10, 11, 12, 14, 15, 16
U107	4, 9, 10, 11, 13, 14, 15, 16
U108	3, 9, 10, 12, 13, 14, 15, 16
U109	2, 9, 11, 12, 13, 14, 15, 16
U110	1, 10, 11, 12, 13, 14, 15, 16
U111	8, 9, 10, 11, 12, 13, 14, 15
U112	7, 9, 10, 11, 12, 13, 14, 16,

These bars will have either Black dots,
or lines, or are missing entirely.

Additional Troubleshooting Information

GRAY SCALE

The gray scale is another way of checking out all of the 299's and associated circuitry. Each 299 produces a certain pattern when bits are missing or if a 299 is bad. The table below will help you locate which 299 produces a problem.

<u>299</u>	<u>COLOR</u>	<u>COLOR SQUARES</u>	<u>BARS</u>
U97	Purple	NONE	4, 6, 7, 8
U98	Purple	Green	1, 2, 3, 5, 6, 8
U107	Yellow	NONE	4, 6, 7, 8
U108	Yellow	Blue	1, 2, 3, 5, 6, 8
U109	Gray	NONE	3, 5, 6, 7, 8
U110	Gray	NONE	2, 4, 5, 7, 8
U111	Bluish	NONE	4, 6, 7, 8
U112	Bluish	Red	1, 2, 3, 5, 6, 8

TROUBLESHOOTING BUS PROBLEMS

The 6809 has a condition code called a NOP (No Operation) when kept in this state, the processor will increment through each address to find its next instruction, so if you keep a NOP on the data side, it will keep on searching for an instruction. What you would see on the address lines is a frequency which is related to the clock frequency. At A0 you will have 1.6 micro-second pulse, A1-3.2 micro-second, A2 will be 6.4 micro-second and so forth up the address lines. Each succeeding address line will be half the frequency of the previous address.

To get this NOP condition, power down the unit and ground TP7 for the Video Board and TP1 for the DSR Board.

CENTURY II

DUAL 6809 SYSTEM - POWER REQUIREMENTS

+5V DC	@	4A for Logic
+12V DC	@	1A for Logic
+12V DC	@	1A (1.5A peak) for Sound
-5V DC	@	5mA

VIDEO BOARD

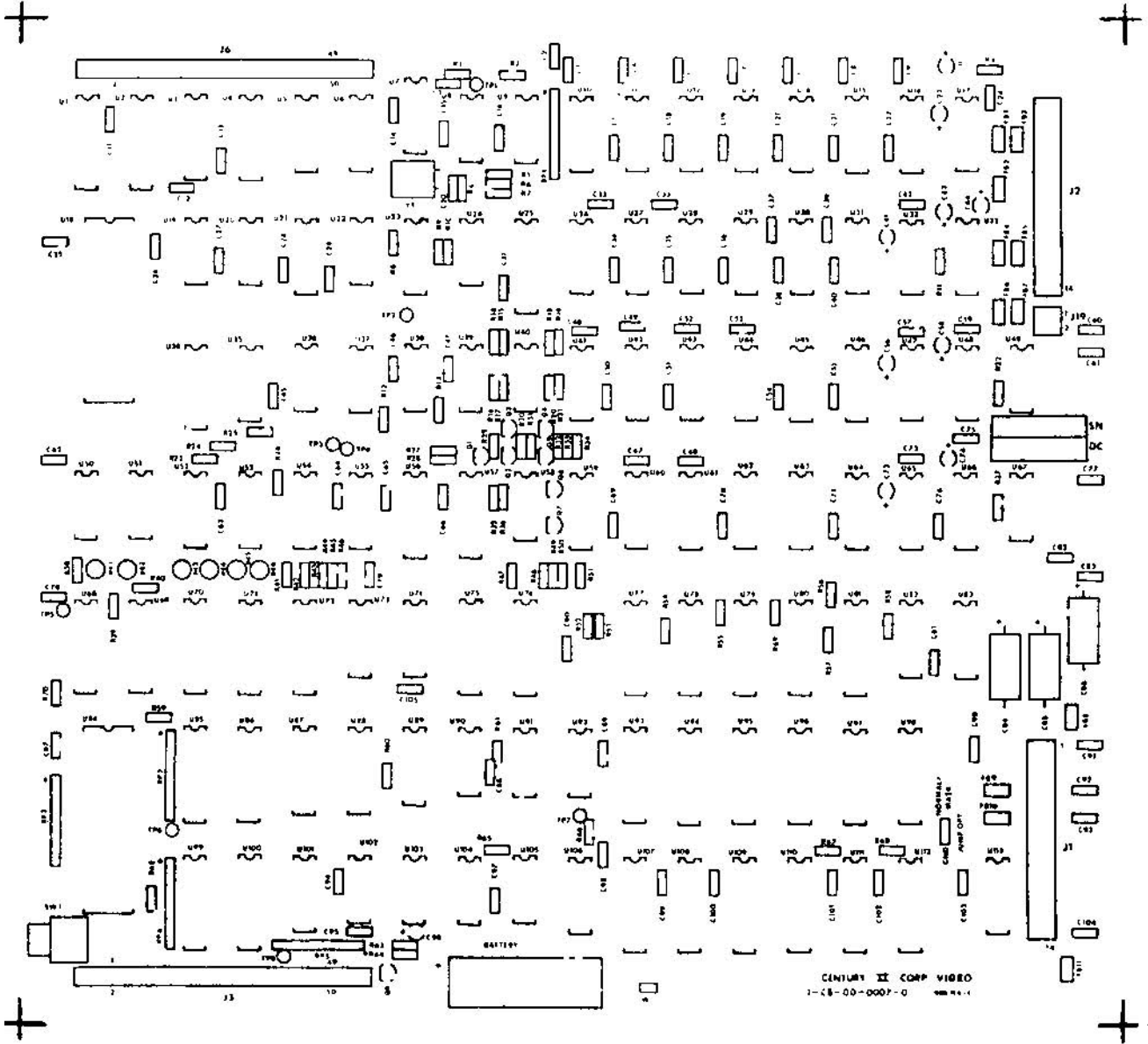

VIDEO BOARD

REF	CTC PART NO.	DESCRIPTION
R1	C-R1-00101-0	Res 100 ohm $\frac{1}{4}$ W 5%
R2	C-R1-00472-0	Res 4.7K ohm $\frac{1}{4}$ W 5%
R3	C-R1-00330-0	Res 33 ohm $\frac{1}{4}$ W 5%
R4	C-R1-00332-0	Res 3.3K ohm $\frac{1}{4}$ W 5%
R5	C-R1-00271-0	Res 270 ohm $\frac{1}{4}$ W 5%
R6	C-R1-00271-0	Res 270 ohm $\frac{1}{4}$ W 5%
R7	C-R1-00271-0	Res 270 ohm $\frac{1}{4}$ W 5%
R8	C-R1-00332-0	Res 3.3 K ohm $\frac{1}{4}$ W 5%
R9	C-R1-00221-0	Res 220 ohm $\frac{1}{4}$ W 5%
R10	C-R1-00222-0	Res 2.2K ohm $\frac{1}{4}$ W 5%
R11	C-R1-00330-0	Res 33 ohm $\frac{1}{4}$ W 5%
R12	C-R1-00330-0	Res 33 ohm $\frac{1}{4}$ W 5%
R13	C-R1-00330-0	Res 33 ohm $\frac{1}{4}$ W 5%
R14	C-R1-00272-0	Res 270 ohm $\frac{1}{4}$ W 5%
R15	C-R1-00151-0	Res 150 ohm $\frac{1}{4}$ W 5%
R16	C-R1-00470-0	Res 47 Ohm $\frac{1}{4}$ W 5%
R17	C-R1-00181-0	Res 180 ohm $\frac{1}{4}$ W 5%
R18	C-R1-00151-0	Res 150 ohm $\frac{1}{4}$ W 5%
R19	C-R1-00271-0	Res 270 ohm $\frac{1}{4}$ W 5%
R20	C-R1-00181-0	Res 180 ohm $\frac{1}{4}$ W 5%
R21	C-R1-00470-0	Res 47 ohm $\frac{1}{4}$ W 5%
R22	C-R1-00330-0	Res 33 ohm $\frac{1}{4}$ W 5%
R23	C-R1-00330-0	Res 33 ohm $\frac{1}{4}$ W 5%
R24	C-R1-00330-0	Res 33 ohm $\frac{1}{4}$ W 5%
R25	C-R1-00330-0	Res 33 ohm $\frac{1}{4}$ W 5%
R26	C-R1-00330-0	Res 33 ohm $\frac{1}{4}$ W 5%
R27	C-R1-00330-0	Res 33 ohm $\frac{1}{4}$ W 5%
R28	C-R1-00330-0	Res 33 ohm $\frac{1}{4}$ W 5%
R29	C-R1-00181-0	Res 180 ohm $\frac{1}{4}$ W 5%
R30	C-R1-00471-0	Res 470 ohm $\frac{1}{4}$ W 5%
R31	C-R1-00471-0	Res 470 ohm $\frac{1}{4}$ W 5%
R32	C-R1-00471-0	Res 470 ohm $\frac{1}{4}$ W 5%
R33	C-R1-00471-0	Res 470 ohm $\frac{1}{4}$ W 5%
R34	C-R1-00471-0	Res 470 ohm $\frac{1}{4}$ W 5%
R35	C-R1-00681-0	Res 680 ohm $\frac{1}{4}$ W 5%
R36	C-R1-00391-0	Res 390 ohm $\frac{1}{4}$ W 5%
R37	C-R1-00330-0	Res 33 ohm $\frac{1}{4}$ W 5%

REF	CTC PART NO.	DESCRIPTION
R38	C-R1-00471-0	Res 47K ohm $\frac{1}{4}$ W 5%
R39	C-R1-00471-0	Res 47K ohm $\frac{1}{4}$ W 5%
R40	C-R1-00332-0	Res 3.3 K ohm $\frac{1}{4}$ W 5%
R41	C-R1-00331-0	Res 330 ohm $\frac{1}{4}$ W 5%
R42	C-R1-00331-0	Res 330 ohm $\frac{1}{4}$ W 5%
R43	C-R1-00331-0	Res 330 ohm $\frac{1}{4}$ W 5%
R44	C-R1-00331-0	Res 330 ohm $\frac{1}{4}$ W 5%
R45	C-R1-00331-0	Res 330 ohm $\frac{1}{4}$ W 5%
R46	C-R1-00331-0	Res 330 ohm $\frac{1}{4}$ W 5%
R47	C-R1-00151-0	Res 150 ohm $\frac{1}{4}$ W 5%
R48	C-R1-00470-0	Res 47 ohm $\frac{1}{4}$ W 5%
R49	C-R1-00471-0	Res 470 ohm $\frac{1}{4}$ W 5%
R50	C-R1-00181-0	Res 180 ohm $\frac{1}{4}$ W 5%
R51	C-R1-00271-0	Res 270 ohm $\frac{1}{4}$ W 5%
R52	C-R1-00330-0	Res 33 ohm $\frac{1}{4}$ W 5%
R53	C-R1-00330-0	Res 33 ohm $\frac{1}{4}$ W 5%
R54	C-R1-00330-0	Res 33 ohm $\frac{1}{4}$ W 5%
R55	C-R1-00330-0	Res 33 ohm $\frac{1}{4}$ W 5%
R56	C-R1-00330-0	Res 33 ohm $\frac{1}{4}$ W 5%
R57	C-R1-00330-0	Res 33 ohm $\frac{1}{4}$ W 5%
R58	C-R1-00330-0	Res 33 ohm $\frac{1}{4}$ W 5%
R59	C-R1-00332-0	Res 3.3K ohm $\frac{1}{4}$ W 5%
R60	C-R1-00391-0	Res 390 ohm $\frac{1}{4}$ W 5%
R61	C-R1-00332-0	Res 3.3 K ohm $\frac{1}{4}$ W 5%
R62	C-R1-00102-0	Res 1K ohm $\frac{1}{4}$ W 5%
R63	C-R1-00121-0	Res 120 ohm $\frac{1}{4}$ W 5%
R64	C-R1-00151-0	Res 150 ohm $\frac{1}{4}$ W 5%
R65	C-R1-00332-0	Res 3.3 K ohm $\frac{1}{4}$ W 5%
R66	C-R1-00332-0	Res 3.3 K ohm $\frac{1}{4}$ W 5%
R67	C-R1-00332-0	Res 3.3 K ohm $\frac{1}{4}$ W 5%
R68	C-R1-00332-0	Res 3.3 K ohm $\frac{1}{4}$ W 5%
R69	C-R1-00330-0	Res 33 ohm $\frac{1}{4}$ W 5%
R70	C-R1-00471-0	Res 47K ohm $\frac{1}{4}$ W 5%
RP1	C-R4-00102-0	Res SIP 1K ohm
RP2	C-R4-00473-0	Res SIP 47K ohm
RP3	C-R4-00332-0	Res SIP 3.3K ohm
RP4	C-R4-00332-0	Res SIP 3.3K ohm

VIDEO BOARD

REF	CTC PART NO.	DESCRIPTION
RP5	C-R4-00332-0	Res SIP 3.3K ohm
C1	C-C1-30103-0	Cap CER AX .01 MFD
C2	C-C1-30104-0	Cap CER AX 0.1 MFD 50V
C3	C-C1-30104-0	Cap CER AX 0.1 MFD 50V
C4	C-C1-30104-0	Cap CER AX 0.1 MFD 50V
C5	C-C1-30104-0	Cap CER AX 0.1 MFD 50V
C6	C-C1-30104-0	Cap CER AX 0.1 MFD 50V
C7	C-C1-30104-0	Cap CER AX 0.1 MFD 50V
C8	C-C1-30104-0	Cap CER AX 0.1 MFD 50V
C9	C-C1-30104-0	Cap CER AX 0.1 MFD 50V
C10	C-C1-10106-0	Cap TANT 10 MFD 16V
C11	C-C1-30104-0	Cap CER AX 0.1 MFD 50V
C12	C-C1-30104-0	Cap CER AX 0.1 MFD 50V
C13	C-C1-30104-0	Cap CER AX 0.1 MFD 50V
C14	C-C1-30104-0	Cap CER AX 0.1 MFD 50V
C15	C-C1-30470-0	Cap CER NPO AX 47 PF
C16	C-C1-30104-0	Cap CER AX 0.1 MFD 50V
C17	C-C1-30104-0	Cap CER AX 0.1 MFD 50V
C18	C-C1-30104-0	Cap CER AX 0.1 MFD 50V
C19	C-C1-30104-0	Cap CER AX 0.1 MFD 50V
C20	C-C1-30104-0	Cap CER AX 0.1 MFD 50V
C21	C-C1-30104-0	Cap CER AX 0.1 MFD 50V
C22	C-C1-30104-0	Cap CER AX 0.1 MFD 50V
C23	C-C1-10106-0	Cap TANT 10 MFD 16V
C24	C-C1-30104-0	Cap CER AX 0.1 MFD 50V
C25	C-C1-30104-0	Cap CER AX 0.1 MFD 50V
C26	C-C1-30104-0	Cap CER AX 0.1 MFD 50V
C27	C-C1-30104-0	Cap CER AX 0.1 MFD 50V
C28	C-C1-30104-0	Cap CER AX 0.1 MFD 50V
C29	C-C1-30104-0	Cap CER AX 0.1 MFD 50V
C30	C-C1-30470-0	Cap CER NPO AX 47 PF
C31	C-C1-30104-0	Cap CER AX 0.1 MFD 50V
C32	C-C1-30104-0	Cap CER AX 0.1 MFD 50V
C33	C-C1-30104-0	Cap CER AX 0.1 MFD 50V
C34	C-C1-30104-0	Cap CER AX 0.1 MFD 50V
C35	C-C1-30104-0	Cap CER AX 0.1 MFD 50V
C36	C-C1-30104-0	Cap CER AX 0.1 MFD 50V

REF	CTC PART NO.	DESCRIPTION
C37	C-C1-30104-0	Cap CER AX 0.1 MFD 50V
C38	C-C1-30104-0	Cap CER AX 0.1 MFD 50V
C39	C-C1-30104-0	Cap CER AX 0.1 MFD 50V
C40	C-C1-30104-0	Cap CER AX 0.1 MFD 50V
C41	C-C1-10106-0	Cap TANT 10 MFD 16V
C42	C-C1-30104-0	Cap CER AX 0.1 MFD 50V
C43	C-C1-10106-0	Cap TANT 10 MFD 16V
C44	C-C1-10106-0	Cap TANT 10 MFD 16V
C45	C-C1-30104-0	Cap CER AX 0.1 MFD 50V
C46	C-C1-30104-0	Cap CER AX 0.1 MFD 50V
C47	C-C1-30104-0	Cap CER AX 0.1 MFD 50V
C48	C-C1-30104-0	Cap CER AX 0.1 MFD 50V
C49	C-C1-30104-0	Cap CER AX 0.1 MFD 50V
C50	C-C1-30104-0	Cap CER AX 0.1 MFD 50V
C51	C-C1-30104-0	Cap CER AX 0.1 MFD 50V
C52	C-C1-30104-0	Cap CER AX 0.1 MFD 50V
C53	C-C1-30104-0	Cap CER AX 0.1 MFD 50V
C54	C-C1-30104-0	Cap CER AX 0.1 MFD 50V
C55	C-C1-30104-0	Cap CER AX 0.1 MFD 50V
C56	C-C1-10106-0	Cap TANT 10 MFD 16V
C57	C-C1-30104-0	Cap CER AX 0.1 MFD 50V
C58	C-C1-10106-0	Cap TANT 10 MFD 16V
C59	C-C1-30104-0	Cap CER AX 0.1 MFD 50V
C60	C-C1-30471-0	Cap CER AX 470 PFD/50V
C61	C-C1-30104-0	Cap CER AX 0.1 MFD 50V
C62	C-C1-30104-0	Cap CER AX 0.1 MFD 50V
C63	C-C1-30104-0	Cap CER AX 0.1 MFD 50V
C64	C-C1-30104-0	Cap CER AX 0.1 MFD 50V
C65	C-C1-30104-0	Cap CER AX 0.1 MFD 50V
C66	C-C1-30104-0	Cap CER AX 0.1 MFD 50V
C67	C-C1-30104-0	Cap CER AX 0.1 MFD 50V
C68	C-C1-30104-0	Cap CER AX 0.1 MFD 50V
C69	C-C1-30104-0	Cap CER AX 0.1 MFD 50V
C70	C-C1-30104-0	Cap CER AX 0.1 MFD 50V
C71	C-C1-30104-0	Cap CER AX 0.1 MFD 50V
C72	C-C1-10106-0	Cap TANT 10 MFD 16V
C73	C-C1-30104-0	Cap CER AX 0.1 MFD 50V

VIDEO BOARD

REF	CTC PART NO.	DESCRIPTION
C74	C-C1-10106-0	Cap TANT 10 MFD
C75	C-C1-30104-0	Cap CER AX 0.1 MFD 50V
C76	C-C1-30104-0	Cap CER AX 0.1 MFD 50V
C77	C-C1-30104-0	Cap CER AX 0.1 MFD 50V
C78	C-C1-30104-0	Cap CER AX 0.1 MFD 50V
C79	C-C1-30104-0	Cap CER AX 0.1 MFD 50V
C80	C-C1-30104-0	Cap CER AX 0.1 MFD 50V
C81	C-C1-30104-0	Cap CER AX 0.1 MFD 50V
C82	C-C1-30104-0	Cap CER AX 0.1 MFD 50V
C83	C-C1-30104-0	Cap CER AX 0.1 MFD 50V
C84	C-C1-00107-0	Cap ELECT 100 MFD 25V
C85	C-C1-00107-0	Cap ELECT 100 MFD 25V
C86	C-C1-00107-0	Cap ELECT 100 MFD 25V
C87	C-C1-30104-0	Cap CER AX 0.1 MFD 50V
C88	C-C1-30104-0	Cap CER AX 0.1 MFD 50V
C89	C-C1-30104-0	Cap CER AX 0.1 MFD 50V
C90	C-C1-30104-0	Cap CER AX 0.1 MFD 50V
C91	C-C1-30471-0	Cap CER AX 470 PFD 50V
C92	C-C1-30471-0	Cap CER AX 470 PFD 50V
C93	C-C1-30471-0	Cap CER AX 470 PFD 50V
C94	C-C1-30104-0	Cap CER AX 0.1 MFD 50V
C95	C-C1-30104-0	Cap CER AX 0.1 MFD 50V
C96	C-C1-10106-0	Cap TANT 10 MFD 16V
C97	C-C1-30104-0	Cap CER AX 0.1 MFD 50V
C98	C-C1-30104-0	Cap CER AX 0.1 MFD 50V
C99	C-C1-30104-0	Cap CER AX 0.1 MFD 50V
C100	C-C1-30104-0	Cap CER AX 0.1 MFD 50V
C101	C-C1-30104-0	Cap CER AX 0.1 MFD 50V
C102	C-C1-30104-0	Cap CER AX 0.1 MFD 50V
C103	C-C1-30104-0	Cap CER AX 0.1 MFD 50V
C104	C-C1-30471-0	Cap CER AX 470 PFD/50V
C105	C-C1-30104-0	Cap CER AX 0.1 MFD 50V
LED1	C-D1-00001-0	LED RED T-1-3/4
LED2	C-D1-00001-0	LED RED T-1-3/4
LED3	C-D1-00001-0	LED RED T-1-3/4
LED4	C-D1-00001-0	LED RED T-1-3/4
LED5	C-D1-00001-0	LED RED T-1-3/4

REF	CTC PART NO.	DESCRIPTION
LED6	C-D1-00001-0	LED RED T-1-3/4
Q1	C-T1-03904-0	TRAN NPN 2N3904
Q2	C-T1-03904-0	TRAN NPN 2N3904
Q3	C-T1-03904-0	TRAN NPN 2N3904
Q4	C-T1-03904-0	TRAN NPN 2N3904
Q5	C-T1-03904-0	TRAN NPN 2N3904
Q6	C-T1-03904-0	TRAN NPN 2N3904
Q7	C-T1-03904-0	TRAN NPN 2N3904
Q8	C-T1-03905-0	TRAN PNP 2N3905
U1	C-A3-10245-2	74LS245 BUS TRANSCEIVER
U2	C-A3-10245-2	74LS245 BUS TRANSCEIVER
U3	C-A2-10113-0	RAM 1KX4NMOS STATIC 2114
U4	C-A2-10113-0	RAM 1KX4NMOS STATIC 2114
U5	C-A3-10157-2	74LS157 MPX DUAL INP
U6	C-A3-10157-2	74LS157 MPX DUAL INP
U7	C-A3-10074-2	74LS74 DUAL D FLIP FLOP
U8	C-A3-10032-2	74LS32 QUAD 2 INP OR
U9	C-A3-10032-2	74LS32 QUAD 2 INP OR
U10	C-A2-10111-0	RAM 16KX1 DYNAMIC 4116
U11	C-A2-10111-0	RAM 16KX1 DYNAMIC 4116
U12	C-A2-10111-0	RAM 16KX1 DYNAMIC 4116
U13	C-A2-10111-0	RAM 16KX1 DYNAMIC 4116
U14	C-A2-10111-0	RAM 16KX1 DYNAMIC 4116
U15	C-A2-10111-0	RAM 16KX1 DYNAMIC 4116
U16	C-A2-10111-0	RAM 16KX1 DYNAMIC 4116
U17	C-A2-10111-0	RAM 16KX1 DYNAMIC 4116
U18	C-A6-06845-0	CRT CONTROLLER 68A45
U19	C-A3-10086-2	74LS86 QUAD 2 INP EXOR
U20	C-A3-10086-2	74LS86 QUAD 2 INP EXOR
U21	C-A3-10157-2	74LS157 MPX DUAL INP
U22	C-A3-10032-2	74LS32 QUAD 2 INP OR
U23	C-A3-10161-2	74LS161 COUNTER 4 BIT
U24	C-A3-10004-2	74LS04 HEX INVERTER
U25	C-A3-20374-2	74S374 SCHOTTKY OCTAL LATCH
U26	C-A2-10111-0	RAM 16KX1 DYNAMIC 4116
U27	C-A2-10111-0	RAM 16KX1 DYNAMIC 4116
U28	C-A2-10111-0	RAM 16KX1 DYNAMIC 4116

VIDEO BOARD

REF	CTC PART NO.	DESCRIPTION
U29	C-A2-10111-0	RAM 16KX1 DYNAMIC 4116
U30	C-A2-10111-0	RAM 16KX1 DYNAMIC 4116
U31	C-A2-10111-0	RAM 16KX1 DYNAMIC 4116
U32	C-A2-10111-0	RAM 16KX1 DYNAMIC 4116
U33	C-A2-10111-0	RAM 16KX1 DYNAMIC 4116
U34	C-A3-10374-2	74LS374 OCTAL LATCH
U35	C-A3-10153-2	74LS153 MPX DUAL INP
U36	C-A3-10074-2	74LS74 DUAL D FLIP FLOP
U37	C-A3-10008-2	74LS08 QUAD INP AND
U38	C-A3-20113-2	74S113 SCHOTTKY JK FLIP
U39	C-A3-10004-2	74LS04 HEX INVERTER
U40	C-A3-00017-2	7417 HEX BUFFER DRIVER
U41	C-A2-10111-0	RAM 16KX1 DYNAMIC 4116
U42	C-A2-10111-0	RAM 16KX1 DYNAMIC 4116
U43	C-A2-10111-0	RAM 16KX1 DYNAMIC 4116
U44	C-A2-10111-0	RAM 16KX1 DYNAMIC 4116
U45	C-A2-10111-0	RAM 16KX1 DYNAMIC 4116
U46	C-A2-10111-0	RAM 16KX1 DYNAMIC 4116
U47	C-A2-10111-0	RAM 16KX1 DYNAMIC 4116
U48	C-A2-10111-0	RAM 16KX1 DYNAMIC 4116
U49	C-A3-10032-2	74LS32 QUAD 2 INP OR
U50	C-A3-10086-2	74LS86 QUAD 2 INP EXOR
U51	C-A3-10086-2	74LS86 QUAD 2 INP EXOR
U52	C-A3-10153-2	74LS153 MPX DUAL INP
U53	C-A3-10153-2	74LS153 MPX DUAL INP
U54	C-A3-10153-2	74LS153 MPX DUAL INP
U55	C-A3-10157-2	74LS157 MPX DUAL INP
U56	C-A2-10114-0	RAM 1KX4HMOS 2148 STATIC
U57	C-A2-10114-0	RAM 1KX4HMOS 2148 STATIC
U58	C-A3-00017-2	7417 HEX BUFFER DRIVER
U59	C-A2-10111-0	RAM 16KX1 DYNAMIC 4116
U60	C-A2-10111-0	RAM 16KX1 DYNAMIC 4116
U61	C-A2-10111-0	RAM 16KX1 DYNAMIC 4116
U62	C-A2-10111-0	RAM 16KX1 DYNAMIC 4116
U63	C-A2-10111-0	RAM 16KX1 DYNAMIC 4116
U64	C-A2-10111-0	RAM 16KX1 DYNAMIC 4116
U65	C-A2-10111-0	RAM 16KX1 DYNAMIC 4116

REF	CTC PART NO.	DESCRIPTION
U66	C-A2-10111-0	RAM 16KX1 DYNAMIC 4116
U67	C-A3-10032-2	74LS32 QUAD 2 INP OR
U68	C-A3-10244-2	74LS244 OCTAL BUFFER
U69	C-A3-10245-2	74LS245 BUS TRANSCEIVER
U70	C-A3-10374-2	74LS374 OCTAL LATCH
U71	C-A3-10374-2	74LS374 OCTAL LATCH
U72	C-A3-10374-2	74LS374 OCTAL LATCH
U73	C-A3-10157-2	74LS157 MPX DUAL INP
U74	C-A3-10157-2	74LS157 MPX DUAL INP
U75	C-A3-10245-2	74LS245 BUS TRANSCEIVER
U76	C-A3-10273-2	74LS273 REGISTER 8 BIT
U77	C-A3-10373-2	74LS373 OCTAL LATCH
U78	C-A3-10373-2	74LS373 OCTAL LATCH
U79	C-A3-10373-2	74LS373 OCTAL LATCH
U80	C-A3-10373-2	74LS373 OCTAL LATCH
U81	C-A3-10374-2	74LS374 OCTAL LATCH
U82	C-A3-10158-2	74LS158 QUAD MULTIPLEX
U83	C-A3-10158-2	74LS158 QUAD MULTIPLEX
U84	C-A1-06891-0	MICROPROCESSOR 68A09E
U85	C-A3-10244-2	74LS244 OCTAL BUFFER
U86	C-A3-10244-2	74LS244 OCTAL BUFFER
U87	C-A2-10112-0	RAM 1KX4CMOS STATIC 6514
U88	C-A2-10112-0	RAM 1KX4CMOS STATIC 6514
U89	C-A3-10139-2	74LS139 DECODER DUAL
U90	C-A3-10032-2	74LS32 QUAD 2 INP OR
U91	C-A3-10074-2	74LS74 DUAL D FLIP FLOP
U92	C-A3-10004-2	74LS04 HEX INVERTER
U93	C-A3-10374-2	74LS374 OCTAL LATCH
U94	C-A3-10374-2	74LS374 OCTAL LATCH
U95	C-A3-10374-2	74LS374 OCTAL LATCH
U96	C-A3-10374-2	74LS374 OCTAL LATCH
U97	C-A3-10299-2	74LS299 SHIFT REGISTER 8 BIT
U98	C-A3-10299-2	74LS299 SHIFT REGISTER 8 BIT
U99	C-A3-10244-2	74LS244 OCTAL BUFFER
U100	C-A3-10244-2	74LS244 OCTAL BUFFER
U101	C-A3-10138-2	74LS138 DECODER 1 of 8
U102	C-A3-6000-2	74C00 QUAD 2 INP NAND

-31-
VIDEO BOARD

REF	CTC PART NO.	DESCRIPTION
U103	C-A3-10008-2	74LS08 QUAD INP AND
U104	C-A3-10010-2	74LS10 TRIPLE 3 INP NAND
U105	C-A3-10000-2	74LS00 QUAD 2 INP NAND
U106	C-A3-10157-2	74LS157 MPX DUAL INP
U107	C-A3-10299-2	74LS299 SHIFT REGISTER 8 BIT
U108	C-A3-10299-2	74LS299 SHIFT REGISTER 8 BIT
U109	C-A3-10299-2	74LS299 SHIFT REGISTER 8 BIT
U110	C-A3-10299-2	74LS299 SHIFT REGISTER 8 BIT
U111	C-A3-10299-2	74LS299 SHIFT REGISTER 8 BIT
U112	C-A3-10299-2	74LS299 SHIFT REGISTER 8 BIT
U113	C-A3-10157-2	74LS157 MPX DUAL INP
XU3	C-S1-00018-0	SOCKET 18 PIN DIP
XU4	C-S1-00018-0	SOCKET 18 PIN DIP
XU10	C-S1-00016-0	SOCKET 16 PIN DIP
XU11	C-S1-00016-0	SOCKET 16 PIN DIP
XU12	C-S1-00016-0	SOCKET 16 PIN DIP
XU13	C-S1-00016-0	SOCKET 16 PIN DIP
XU14	C-S1-00016-0	SOCKET 16 PIN DIP
XU15	C-S1-00016-0	SOCKET 16 PIN DIP
XU16	C-S1-00016-0	SOCKET 16 PIN DIP
XU17	C-S1-00016-0	SOCKET 16 PIN DIP
XU18	C-S1-00040-0	SOCKET 40 PIN DIP
XU26	C-S1-00016-0	SOCKET 16 PIN DIP
XU27	C-S1-00016-0	SOCKET 16 PIN DIP
XU28	C-S1-00016-0	SOCKET 16 PIN DIP
XU29	C-S1-00016-0	SOCKET 16 PIN DIP
XU30	C-S1-00016-0	SOCKET 16 PIN DIP
XU31	C-S1-00016-0	SOCKET 16 PIN DIP
XU32	C-S1-00016-0	SOCKET 16 PIN DIP
XU33	C-S1-00016-0	SOCKET 16 PIN DIP
XU41	C-S1-00016-0	SOCKET 16 PIN DIP
XU42	C-S1-00016-0	SOCKET 16 PIN DIP
XU43	C-S1-00016-0	SOCKET 16 PIN DIP
XU44	C-S1-00016-0	SOCKET 16 PIN DIP
XU45	C-S1-00016-0	SOCKET 16 PIN DIP
XU46	C-S1-00016-0	SOCKET 16 PIN DIP
XU47	C-S1-00016-0	SOCKET 16 PIN DIP

REF	CTC PART NO.	DESCRIPTION
XU48	C-S1-00016-0	SOCKET 16 PIN DIP
XU56	C-S1-00018-0	SOCKET 18 PIN DIP
XU57	C-S1-00018-0	SOCKET 18 PIN DIP
XU59	C-S1-00016-0	SOCKET 16 PIN DIP
XU60	C-S1-00016-0	SOCKET 16 PIN DIP
XU61	C-S1-00016-0	SOCKET 16 PIN DIP
XU62	C-S1-00016-0	SOCKET 16 PIN DIP
XU63	C-S1-00016-0	SOCKET 16 PIN DIP
XU64	C-S1-00016-0	SOCKET 16 PIN DIP
XU65	C-S1-00016-0	SOCKET 16 PIN DIP
XU66	C-S1-00016-0	SOCKET 16 PIN DIP
XU84	C-S1-00040-0	SOCKET 40 PIN DIP
XU87	C-S1-00018-0	SOCKET 18 PIN DIP
XU88	C-S1-00018-0	SOCKET 18 PIN DIP
FB1	C-K1-00100-0	FERRITE BEAD
FB2	C-K1-00100-0	FERRITE BEAD
FB3	C-K1-00100-0	FERRITE BEAD
FB4	C-K1-00100-0	FERRITE BEAD
FB5	C-K1-00100-0	FERRITE BEAD
FB6	C-K1-00100-0	FERRITE BEAD
FB7	C-K1-00100-0	FERRITE BEAD
FB8	C-K1-00100-0	FERRITE BEAD
FB9	C-K1-00100-0	FERRITE BEAD
FB10	C-K1-00100-0	FERRITE BEAD
FB11	C-K1-00100-0	FERRITE BEAD
Y1	C-X1-00100-0	CRYSTAL 20,000 MHz
BATT	C-Y1-00100-0	NICAD BATT. 3.6V 1/3AA
J1	C-V1-00014-0	CONN 14 PIN 0.156 CTR.
J2	C-V1-00014-0	CONN 14 PIN 0.156 CTR.
J3	C-V1-10050-0	CONN HDR VERT. 50 PIN
J6	C-V1-10050-0	CONN HDR VERT. 50 PIN
J19	C-V1-00002-0	CONN 2 PIN 0.156 CTR
W1	C-V1-01000-0	CONN 0.1 CTR
W1	C-V4-01000-0	PLUG SHORTNING
SW1	C-W1-00001-0	SWITCH MOMENTARY
PCB 0007	1-CB-00-0007-0	PCB - VIDEO

-32-
DSR BOARD

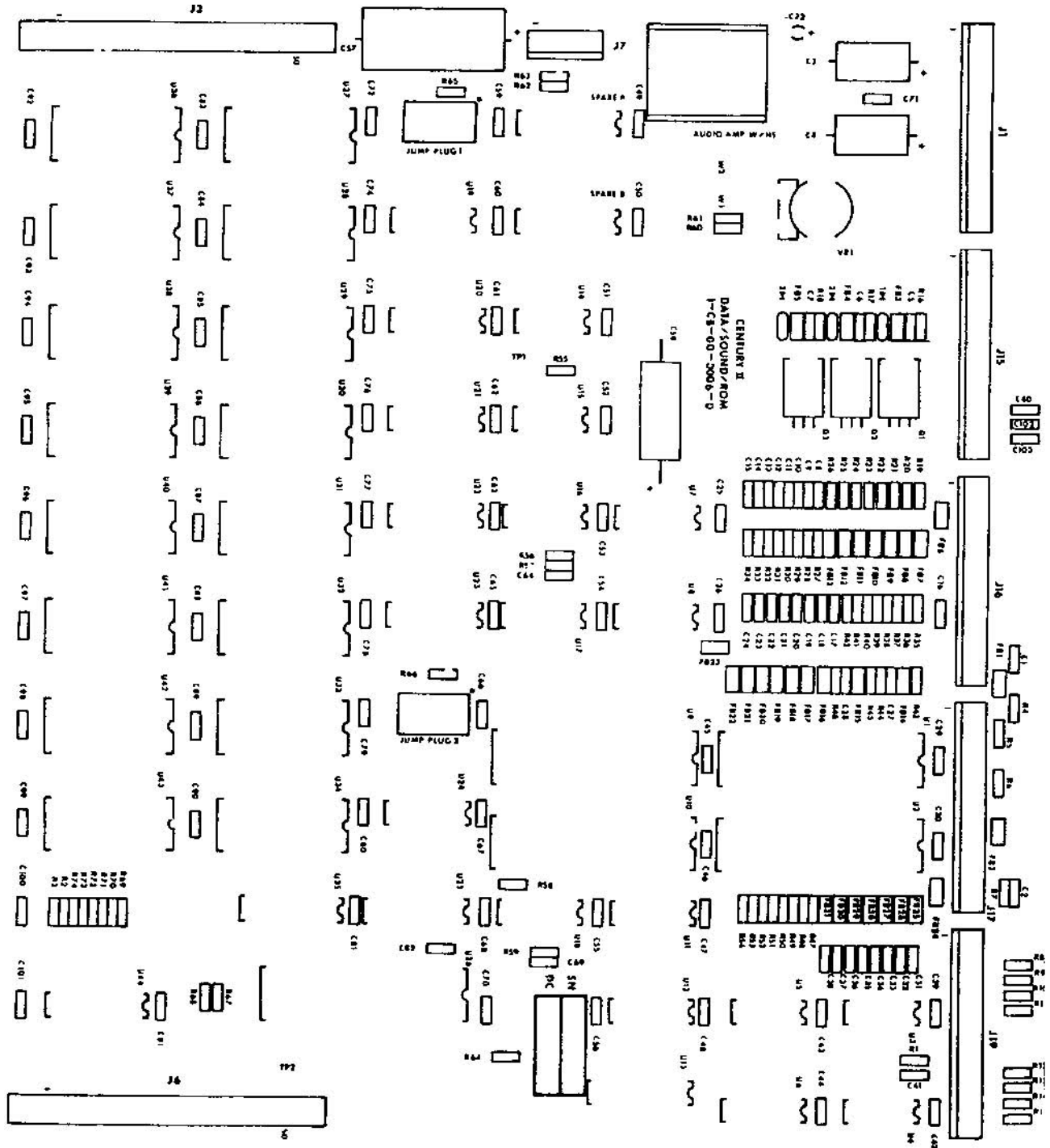

DSR BOARD

REF	CTC PART NO.	DESCRIPTION
R1	C-R1-00100-0	Res 100 ohm $\frac{1}{2}$ W 5%
R2	C-R1-00473-0	Res 47K ohm $\frac{1}{2}$ W 5%
R3	C-R1-00473-0	Res 47K ohm $\frac{1}{2}$ W 5%
R4	C-R1-00471-0	Res 470 ohm $\frac{1}{2}$ W 5%
R5	C-R1-00562-0	Res 5.6K ohm $\frac{1}{2}$ W 5%
R6	C-R1-00562-0	Res 5.6K ohm $\frac{1}{2}$ W 5%
R7	C-R1-00471-0	Res 470 ohm $\frac{1}{2}$ W 5%
R8	C-R1-00332-0	Res 3.3K ohm $\frac{1}{2}$ W 5%
R9	C-R1-00332-0	Res 3.3K ohm $\frac{1}{2}$ W 5%
R10	C-R1-00332-0	Res 3.3K ohm $\frac{1}{2}$ W 5%
R11	C-R1-00332-0	Res 3.3K ohm $\frac{1}{2}$ W 5%
R12	C-R1-00332-0	Res 3.3K ohm $\frac{1}{2}$ W 5%
R13	C-R1-00332-0	Res 3.3K ohm $\frac{1}{2}$ W 5%
R14	C-R1-00332-0	Res 3.3K ohm $\frac{1}{2}$ W 5%
R15	C-R1-00332-0	Res 3.3K ohm $\frac{1}{2}$ W 5%
R16	C-R1-00471-0	Res 470 ohm $\frac{1}{2}$ W 5%
R17	C-R1-00471-0	Res 470 ohm $\frac{1}{2}$ W 5%
R18	C-R1-00471-0	Res 470 ohm $\frac{1}{2}$ W 5%
R19	C-R1-00471-0	Res 470 ohm $\frac{1}{2}$ W 5%
R20	C-R1-00471-0	Res 470 ohm $\frac{1}{2}$ W 5%
R21	C-R1-00471-0	Res 470 ohm $\frac{1}{2}$ W 5%
R22	C-R1-00471-0	Res 470 ohm $\frac{1}{2}$ W 5%
R23	C-R1-00471-0	Res 470 ohm $\frac{1}{2}$ W 5%
R24	C-R1-00471-0	Res 470 ohm $\frac{1}{2}$ W 5%
R25	C-R1-00471-0	Res 470 ohm $\frac{1}{2}$ W 5%
R26	C-R1-00471-0	Res 470 ohm $\frac{1}{2}$ W 5%
R27	C-R1-00562-0	Res 5.6K ohm $\frac{1}{2}$ W 5%
R28	C-R1-00562-0	Res 5.6K ohm $\frac{1}{2}$ W 5%
R29	C-R1-00562-0	Res 5.6K ohm $\frac{1}{2}$ W 5%
R30	C-R1-00562-0	Res 5.6K ohm $\frac{1}{2}$ W 5%
R31	C-R1-00562-0	Res 5.6K ohm $\frac{1}{2}$ W 5%
R32	C-R1-00562-0	Res 5.6K ohm $\frac{1}{2}$ W 5%
R33	C-R1-00562-0	Res 5.6K ohm $\frac{1}{2}$ W 5%
R34	C-R1-00562-0	Res 5.6K ohm $\frac{1}{2}$ W 5%
R35	C-R1-00471-0	Res 470 ohm $\frac{1}{2}$ W 5%
R36	C-R1-00471-0	Res 470 ohm $\frac{1}{2}$ W 5%
R37	C-R1-00471-0	Res 470 ohm $\frac{1}{2}$ W 5%

REF	CTC PART NO.	DESCRIPTION
R38	C-R1-00471-0	Res 470 ohm $\frac{1}{2}$ W 5%
R39	C-R1-00471-0	Res 470 ohm $\frac{1}{2}$ W 5%
R40	C-R1-00471-0	Res 470 ohm $\frac{1}{2}$ W 5%
R41	C-R1-00471-0	Res 470 ohm $\frac{1}{2}$ W 5%
R42	C-R1-00471-0	Res 470 ohm $\frac{1}{2}$ W 5%
R43	C-R1-00562-0	Res 5.6K ohm $\frac{1}{2}$ W 5%
R44	C-R1-00471-0	Res 470 ohm $\frac{1}{2}$ W 5%
R45	C-R1-00562-0	Res 5.6K ohm $\frac{1}{2}$ W 5%
R46	C-R1-00471-0	Res 470 ohm $\frac{1}{2}$ W 5%
R47	C-R1-00471-0	Res 470 ohm $\frac{1}{2}$ W 5%
R48	C-R1-00471-0	Res 470 ohm $\frac{1}{2}$ W 5%
R49	C-R1-00471-0	Res 470 ohm $\frac{1}{2}$ W 5%
R50	C-R1-00471-0	Res 470 ohm $\frac{1}{2}$ W 5%
R51	C-R1-00471-0	Res 470 ohm $\frac{1}{2}$ W 5%
R52	C-R1-00471-0	Res 470 ohm $\frac{1}{2}$ W 5%
R53	C-R1-00471-0	Res 470 ohm $\frac{1}{2}$ W 5%
R54	C-R1-00471-0	Res 470 ohm $\frac{1}{2}$ W 5%
R55	C-R1-00332-0	Res 3.3K ohm $\frac{1}{2}$ W 5%
R56	C-R1-00222-0	Res 2.2K ohm $\frac{1}{2}$ W 5%
R57	C-R1-00182-0	Res 1.8K ohm $\frac{1}{2}$ W 5%
R58	C-R1-00222-0	Res 2.2K ohm $\frac{1}{2}$ W 5%
R59	C-R1-00182-0	Res 1.8K ohm $\frac{1}{2}$ W 5%
R60	C-R1-00332-0	Res 3.3K ohm $\frac{1}{2}$ W 5%
R61	C-R1-00332-0	Res 3.3K ohm $\frac{1}{2}$ W 5%
R62	C-R1-01022-0	Res 2.2 ohm $\frac{1}{2}$ W 5%
R63	C-R1-00221-0	Res 220 ohm $\frac{1}{2}$ W 5%
R64	C-R1-00332-0	Res 3.3K ohm $\frac{1}{2}$ W 5%
R65	C-R1-00562-0	Res 5.6K ohm $\frac{1}{2}$ W 5%
R66	C-R1-00562-0	Res 5.6K ohm $\frac{1}{2}$ W 5%
R67	C-R1-00332-0	Res 3.3K ohm $\frac{1}{2}$ W 5%
R68	C-R1-00332-0	Res 3.3K ohm $\frac{1}{2}$ W 5%
R69	C-R1-00473-0	Res 47K ohm $\frac{1}{2}$ W 5%
R70	C-R1-00473-0	Res 47K ohm $\frac{1}{2}$ W 5%
R71	C-R1-00473-0	Res 47K ohm $\frac{1}{2}$ W 5%
R72	C-R1-00473-0	Res 47K ohm $\frac{1}{2}$ W 5%
R73	C-R1-00473-0	Res 47K ohm $\frac{1}{2}$ W 5%
R74	C-R1-00473-0	Res 47K ohm $\frac{1}{2}$ W 5%

DSR BOARD

REF	CTC PART NO.	DESCRIPTION
VR1	C-R2-00502-0	Res POT PC Mount 5K ohm
C1	C-C1-30471-0	CAP 470 Pfd CER. 50V
C2	C-C1-30471-0	CAP 470 Pfd CER. 50V
C3	C-C1-00107-0	CAP 100 Mfd ELECTRO 25V
C4	C-C1-00107-0	CAP 100 Mfd ELECTRO 25V
C5	C-C1-30471-0	CAP 470 Pfd CER. 50V
C6	C-C1-30471-0	CAP 470 Pfd CER. 50V
C7	C-C1-30471-0	CAP 470 Pfd CER. 50V
C8	C-C1-30471-0	CAP 470 Pfd CER. 50V
C9	C-C1-30471-0	CAP 470 Pfd CER. 50V
C10	C-C1-30471-0	CAP 470 Pfd CER. 50V
C11	C-C1-30471-0	CAP 470 Pfd CER. 50V
C12	C-C1-30471-0	CAP 470 Pfd CER. 50V
C13	C-C1-30471-0	CAP 470 Pfd CER. 50V
C14	C-C1-30471-0	CAP 470 Pfd CER. 50V
C15	C-C1-30471-0	CAP 470 Pfd CER. 50V
C16	C-C1-30104-0	CAP, .1 Mfd CER. 50V
C17	C-C1-30471-0	CAP 470 Pfd CER. 50V
C18	C-C1-30471-0	CAP 470 Pfd CER. 50V
C19	C-C1-30471-0	CAP 470 Pfd CER. 50V
C20	C-C1-30471-0	CAP 470 Pfd CER. 50V
C21	C-C1-30471-0	CAP 470 Pfd CER. 50V
C22	C-C1-30471-0	CAP 470 Pfd CER. 50V
C23	C-C1-30471-0	CAP 470 Pfd CER. 50V
C24	C-C1-30471-0	CAP 470 Pfd CER. 50V
C25	C-C1-30104-0	CAP, .1 Mfd CER. 50V
C26	C-C1-30104-0	CAP, .1 Mfd CER. 50V
C27	C-C1-30471-0	CAP 470 Pfd CER. 50V
C28	C-C1-30471-0	CAP 470 Pfd CER. 50V
C29	C-C1-30104-0	CAP, .1 Mfd CER. 50V
C30	C-C1-30104-0	CAP, .1 Mfd CER. 50V
C31	C-C1-30471-0	CAP 470 Pfd CER. 50V
C32	C-C1-30471-0	CAP 470 Pfd CER. 50V
C33	C-C1-30471-0	CAP 470 Pfd CER. 50V
C34	C-C1-30471-0	CAP 470 Pfd CER. 50V
C35	C-C1-30471-0	CAP 470 Pfd CER. 50V
C36	C-C1-30471-0	CAP 470 Pfd CER. 50V

REF	CTC PART NO.	DESCRIPTION
C37	C-C1-30471-0	CAP 470 Pfd CER. 50V
C38	C-C1-30471-0	CAP 470 Pfd CER. 50V
C39	C-C1-30104-0	CAP, .1 Mfd CER. 50V
C40	C-C1-30471-0	CAP 470 Pfd CER. 50V
C41	C-C1-30104-0	CAP, .1 Mfd CER. 50V
C42	C-C1-30104-0	CAP, .1 Mfd CER. 50V
C43	C-C1-30104-0	CAP, .1 Mfd CER. 50V
C44	C-C1-30104-0	CAP, .1 Mfd CER. 50V
C45	C-C1-30104-0	CAP, .1 Mfd CER. 50V
C46	C-C1-30104-0	CAP, .1 Mfd CER. 50V
C47	C-C1-30104-0	CAP, .1 Mfd CER. 50V
C48	C-C1-30104-0	CAP, .1 Mfd CER. 50V
C49	C-C1-30104-0	CAP, .1 Mfd CER. 50V
C50	C-C1-30104-0	CAP, .1 Mfd CER. 50V
C51	C-C1-30104-0	CAP, .1 Mfd CER. 50V
C52	C-C1-30104-0	CAP, .1 Mfd CER. 50V
C53	C-C1-30104-0	CAP, .1 Mfd CER. 50V
C54	C-C1-30104-0	CAP, .1 Mfd CER. 50V
C55	C-C1-30104-0	CAP, .1 Mfd CER. 50V
C56	C-C1-30104-0	CAP, .1 Mfd CER. 50V
C57	C-C1-00108-0	CAP 1000 Mfd ELECTRO 25V
C58	C-C1-00471-0	CAP 470 Mfd ELECTRO 16V
C59	C-C1-30104-0	CAP, .1 Mfd CER. 50V
C60	C-C1-30104-0	CAP, .1 Mfd CER. 50V
C61	C-C1-30104-0	CAP, .1 Mfd CER. 50V
C62	C-C1-30104-0	CAP, .1 Mfd CER. 50V
C63	C-C1-30104-0	CAP, .1 Mfd CER. 50V
C64	C-C1-30123-0	CAP .012 Mfd CER. 50V
C65	C-C1-30104-0	CAP, .1 Mfd CER. 50V
C66	C-C1-30104-0	CAP, .1 Mfd CER. 50V
C67	C-C1-30104-0	CAP, .1 Mfd CER. 50V
C68	C-C1-30104-0	CAP, .1 Mfd CER. 50V
C69	C-C1-30123-0	CAP .012 Mfd CER. 50V
C70	C-C1-30104-0	CAP, .1 Mfd CER. 50V
C71	C-C1-30104-0	CAP, .1 Mfd CER. 50V
C72	C-C1-10106-0	CAP TANT 10 Mfd 20V
C73	C-C1-30104-0	CAP, .1 Mfd CER. 50V

-36-
DSR BOARD

	CTC PART NO.	DESCRIPTION
	C-C1-30104-0	CAP, .1 Mfd CER. 50V
C74	C-C1-30104-0	CAP, .1 Mfd CER. 50V
C75	C-C1-30104-0	CAP, .1 Mfd CER. 50V
C76	C-C1-30104-0	CAP, .1 Mfd CER. 50V
C77	C-C1-30104-0	CAP, .1 Mfd CER. 50V
C78	C-C1-30104-0	CAP, .1 Mfd CER. 50V
C79	C-C1-30104-0	CAP, .1 Mfd CER. 50V
C80	C-C1-30104-0	CAP, .1 Mfd CER. 50V
C81	C-C1-30104-0	CAP, .1 Mfd CER. 50V
C82	C-C1-30104-0	CAP, .1 Mfd CER. 50V
C83	C-C1-30104-0	CAP, .1 Mfd CER. 50V
C84	C-C1-30104-0	CAP, .1 Mfd CER. 50V
C85	C-C1-30104-0	CAP, .1 Mfd CER. 50V
C86	C-C1-30104-0	CAP, .1 Mfd CER. 50V
C87	C-C1-30104-0	CAP, .1 Mfd CER. 50V
C88	C-C1-30104-0	CAP, .1 Mfd CER. 50V
C89	C-C1-30104-0	CAP, .1 Mfd CER. 50V
C90	C-C1-30104-0	CAP, .1 Mfd CER. 50V
C91	C-C1-30104-0	CAP, .1 Mfd CER. 50V
C92	C-C1-30104-0	CAP, .1 Mfd CER. 50V
C93	C-C1-30104-0	CAP, .1 Mfd CER. 50V
C94	C-C1-30104-0	CAP, .1 Mfd CER. 50V
C95	C-C1-30104-0	CAP, .1 Mfd CER. 50V
C96	C-C1-30104-0	CAP, .1 Mfd CER. 50V
C97	C-C1-30104-0	CAP, .1 Mfd CER. 50V
C98	C-C1-30104-0	CAP, .1 Mfd CER. 50V
C99	C-C1-30104-0	CAP, .1 Mfd CER. 50V
C100	C-C1-30104-0	CAP, .1 Mfd CER. 50V
C101	C-C1-30104-0	CAP, .1 Mfd CER. 50V
D1	C-D5-04001-0	DIODE IN4001
D2	C-D5-04001-0	DIODE IN4001
D3	C-D5-04001-0	DIODE IN4001
Q1	C-T1-00120-0	TRAN TIP 120
Q2	C-T1-00123-0	TRAN TIP 120
Q3	C-T1-00123-0	TRAN TIP 120
FB1	C-K1-00100-0	FERRITE BEAD
FB2	C-K1-00100-0	FERRITE BEAD
FB3	C-K1-00100-0	FERRITE BEAD

REF	CTC PART NO.	DESCRIPTION
FB4	C-K1-00100-0	FERRITE BEAD
FB5	C-K1-00100-0	FERRITE BEAD
FB6	C-K1-00100-0	FERRITE BEAD
FB7	C-K1-00100-0	FERRITE BEAD
FB8	C-K1-00100-0	FERRITE BEAD
FB9	C-K1-00100-0	FERRITE BEAD
FB10	C-K1-00100-0	FERRITE BEAD
FB11	C-K1-00100-0	FERRITE BEAD
FB12	C-K1-00100-0	FERRITE BEAD
FB13	C-K1-00100-0	FERRITE BEAD
FB14	C-K1-00100-0	FERRITE BEAD
FB15	C-K1-00100-0	FERRITE BEAD
FB16	C-K1-00100-0	FERRITE BEAD
FB17	C-K1-00100-0	FERRITE BEAD
FB18	C-K1-00100-0	FERRITE BEAD
FB19	C-K1-00100-0	FERRITE BEAD
FB20	C-K1-00100-0	FERRITE BEAD
FB21	C-K1-00100-0	FERRITE BEAD
FB22	C-K1-00100-0	FERRITE BEAD
FB23	C-K1-00100-0	FERRITE BEAD
FB24	C-K1-00100-0	FERRITE BEAD
FB25	C-K1-00100-0	FERRITE BEAD
FB26	C-K1-00100-0	FERRITE BEAD
FB27	C-K1-00100-0	FERRITE BEAD
FB28	C-K1-00100-0	FERRITE BEAD
FB29	C-K1-00100-0	FERRITE BEAD
FB30	C-K1-00100-0	FERRITE BEAD
FB31	C-K1-00100-0	FERRITE BEAD
U1	C-A6-06811-0	PARALLEL I/O 68A21
U2	C-A6-06811-0	PARALLEL I/O 68A21
U3	C-A3-74093-2	MC14093 QUAD 2 INP NAND
U4	C-A3-74093-2	MC14093 QUAD 2 INP NAND
U5	C-A3-10074-2	74LS74 DUAL D FLIP/FLOP
U6	C-A3-10157-2	74LS157 MPX QUAD 2 INP
U7	C-A3-10191-2	74LS191 UP/DOWN COUNTER
U8	C-A3-10191-2	74LS191 UP/DOWN COUNTER
U9	C-A6-06811-0	PARALLEL I/O 68A21

USR BOARD

REF	CTC PART NO.	DESCRIPTION
U10	C-A6-06811-0	PARALLEL I/O 68A21
U11	C-A3-10191-2	74LS191 UP/DOWN COUNTER
U12	C-A3-10191-2	74LS191 UP/DOWN COUNTER
U13	C-A3-10244-2	74LS244 OCTAL BUFFER
U14	C-A3-10002-2	74LS02 QUAD 2 INP NOR
U15	C-A3-10004-2	74LS04 HEX INVERTER
U16	C-A3-10138-2	74LS138 DECODER 1 of 8
U17	C-A4-76489-0	76489AN SOUND GENERATOR
U18	C-A4-76489-0	76489AN SOUND GENERATOR
U19	C-A3-10138-2	74LS138 DECODER 1 of 8
U20	C-A2-10113-0	OPTIONAL 2114
U21	C-A2-10113-0	RAM 1KX4 NMOS 2114 STATIC
U22	C-A2-10113-0	OPTIONAL 2114
U23	C-A2-10113-0	RAM 1KX4 NMOS 2114 STATIC
U24	C-A3-10138-2	74LS138 DECODER 1 of 8
U25	C-A3-10244-2	74LS244 OCTAL BUFFER
U26	C-A1-06891-0	MICROPROCESSOR 6809E
U27	C-A2-02716-0	EPROM 2716
U28	C-A2-02716-0	EPROM 2716
U29	C-A2-02716-0	EPROM 2716
U30	C-A2-02716-0	EPROM 2716
U31	C-A2-02716-0	EPROM 2716
U32	C-A2-02716-0	EPROM 2716
U33	C-A2-02716-0	EPROM 2716
U34	C-A2-02716-0	EPROM 2716
U35	C-A3-10244-2	74LS244 OCTAL BUFFER
U36	C-A2-02716-0	EPROM 2716
U37	C-A2-02716-0	EPROM 2716
U38	C-A2-02716-0	EPROM 2716
U39	C-A2-02716-0	EPROM 2716
U40	C-A2-02716-0	EPROM 2716
U41	C-A2-02716-0	EPROM 2716
U42	C-A2-02716-0	EPROM 2716
U43	C-A2-02716-0	EPROM 2716
U44	C-A3-10245-2	74LS245 BUS TRANSCEIVER
U45	C-A4-02002-0	2002 AUDIO AMP
XU16	C-S1-00016-0	SOCKET 16 PIN DIP

REF	CTC PART NO.	DESCRIPTION
XU19	C-S1-00016-0	SOCKET 16 PIN DIP
XU21	C-S1-00018-0	SOCKET 18 PIN DIP
XU23	C-S1-00018-0	SOCKET 18 PIN DIP
XU26	C-S1-00040-0	SOCKET 40 PIN DIP
XU27	C-S1-00024-0	SOCKET 24 PIN DIP
XU28	C-S1-00024-0	SOCKET 24 PIN DIP
XU29	C-S1-00024-0	SOCKET 24 PIN DIP
XU30	C-S1-00024-0	SOCKET 24 PIN DIP
XU31	C-S1-00024-0	SOCKET 24 PIN DIP
XU32	C-S1-00024-0	SOCKET 24 PIN DIP
XU33	C-S1-00024-0	SOCKET 24 PIN DIP
XU34	C-S1-00024-0	SOCKET 24 PIN DIP
XU36	C-S1-00024-0	SOCKET 24 PIN DIP
XU37	C-S1-00024-0	SOCKET 24 PIN DIP
XU38	C-S1-00024-0	SOCKET 24 PIN DIP
XU39	C-S1-00024-0	SOCKET 24 PIN DIP
XU40	C-S1-00024-0	SOCKET 24 PIN DIP
XU41	C-S1-00024-0	SOCKET 24 PIN DIP
XU42	C-S1-00024-0	SOCKET 24 PIN DIP
XU43	C-S1-00024-0	SOCKET 24 PIN DIP
J1	C-V1-00014-0	CONN 14 PIN 0.156 CTR.
J3	C-V1-10050-0	CONN HDR VERT. 50 PIN
J6	C-V1-10050-0	CONN HDR VERT. 50 PIN
J7	C-V1-00005-0	CONN 5 PIN LOCK 0.156 CTR.
J15	C-V1-00014-0	CONN 14 PIN 0.156 CTR.
J16	C-V1-00014-0	CONN 14 PIN 0.156 CTR.
J17	C-V1-00014-0	CONN 14 PIN 0.156 CTR.
J19	C-V1-00014-0	CONN 14 PIN 0.156 CTR.
XJP1	C-S1-00014-0	SOCKET 14 PIN DIP
XJP2	C-S1-00014-0	SOCKET 14 PIN DIP
JP1	C-V5-00014-0	JUMPER 14 PIN
JP2	C-V5-00014-0	JUMPER 14 PIN
PCB 0006	1-CB-00-0006-0	PCB-DSR
AR	C-V8-00001-0	HEAT SINK COMPOUND
	C-S6-00220-0	HEAT SINK TO 220

SERVICE BULLETIN
VERTICAL DEFLECTION CIRCUIT REVISION

NOTE: When requesting service parts or information be sure to mention the monitors model number and serial number.

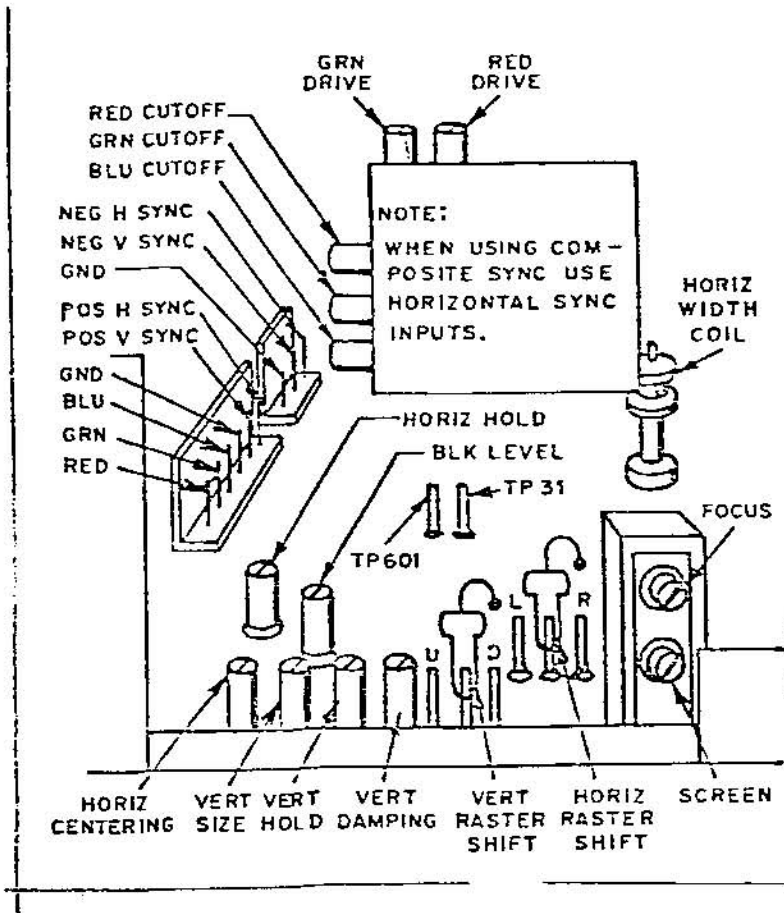

All K4900 Series Monitors including, but not limited to, the following model numbers:

- | | |
|-------|--------|
| K4901 | K4952 |
| K4902 | K4956 |
| K4906 | K4956R |
| K4911 | K4961 |
| K4951 | |

1. IDENTIFICATION

This bulletin applies to those monitors with serial numbers of 400001 and above.

They can be identified by the following:

- A) The model number on the shipping carton and on the monitor is printed in red.
- B) The part number on the deflection yoke is either 2021111258 or 2021111264.
- C) The flyback transformer stabilizing bracket is labeled 611X0005-008.
- D) There is an additional control, the VERTICAL DAMPING CONTROL shown above immediately to the right of the Vertical Hold Control.

2. REASON

The applicable monitors have an improved deflection yoke which provides for faster vertical retrace. This permits more lines of video to be displayed. The VERTICAL DAMPING CONTROL permits the user to adjust the uniformity of spacing of the additional lines.

3. ADJUSTMENT OF THE VERTICAL DAMPING CONTROL

The adjustment of the VERTICAL DAMPING CONTROL is important only if the vertical size is adjusted such that the additional lines appear on the screen. Turn up the Black Level Control such that the raster lines can be seen. Adjust the Vertical Damping Control such that the top raster lines are spaced uniformly and not folded over. Return the Black Level Control to the desired setting.

4. YOKE REPLACEMENT

It is IMPERATIVE that deflection yokes with part numbers 2021111258 and 2021111264 be used only with the chassis identified above. They may not be substituted for deflection yokes with part numbers 202111194 or 2021111201. Conversely, deflection yokes numbered 202111194 and 2021111201 may not be substituted for deflection yokes numbered 2021111258 and 2021111264. Improper matching of chassis and yokes will result in insufficient vertical deflection or improper blanking operation.

SCHEMATICS

VIDEO CPU BOARD
DATA/SOUND/ROM BOARD (DSR BOARD)
POWER SUPPLY
CABINET WIRING
MONITOR (Wells-Gardner 19K4951)

GDI Inc.
207 S. MADISON ST. CHICAGO, IL 60604/312/467-1111

SLITHER CABINET WIRING

6-14-82
REV 6-17-82

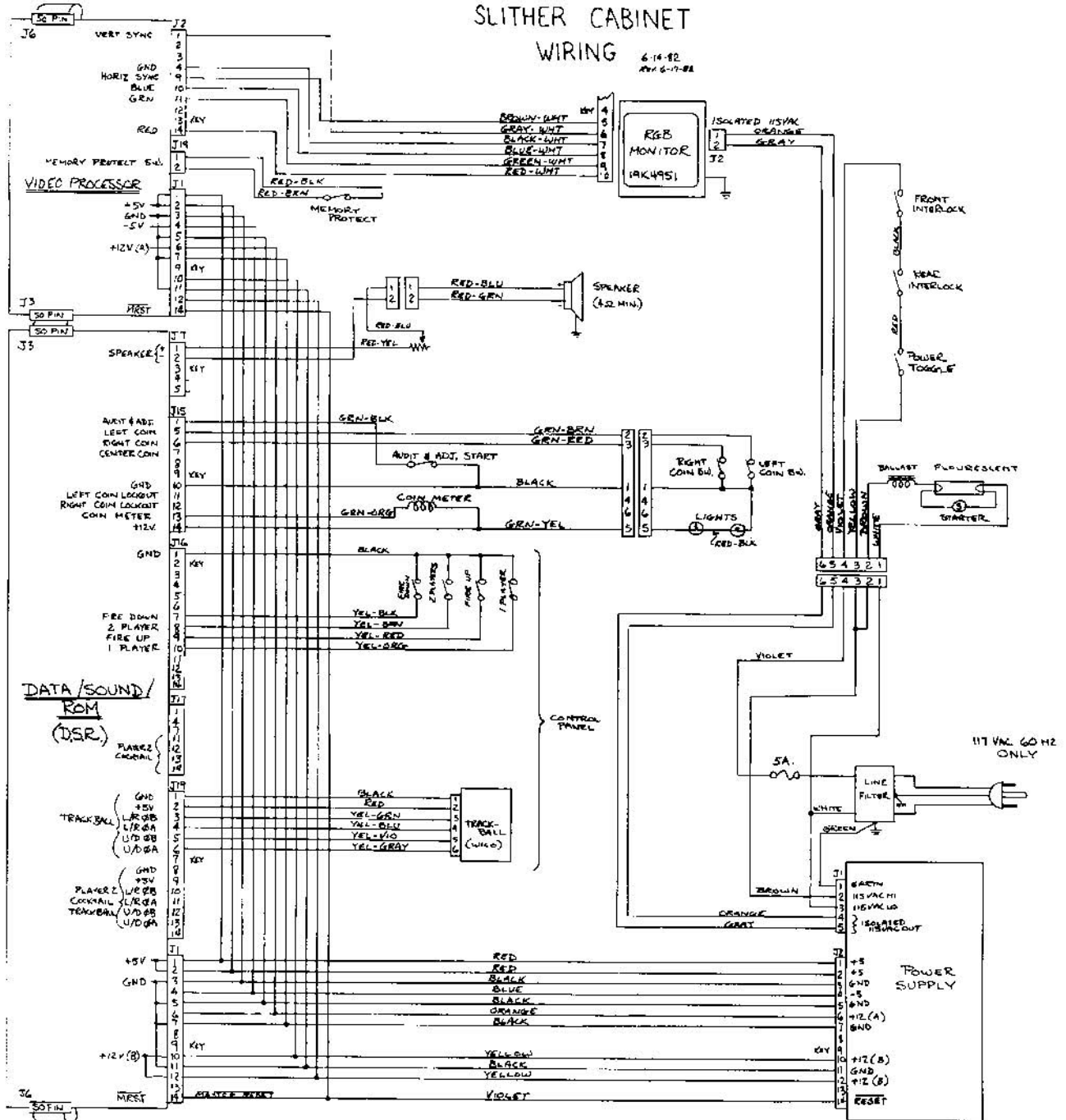

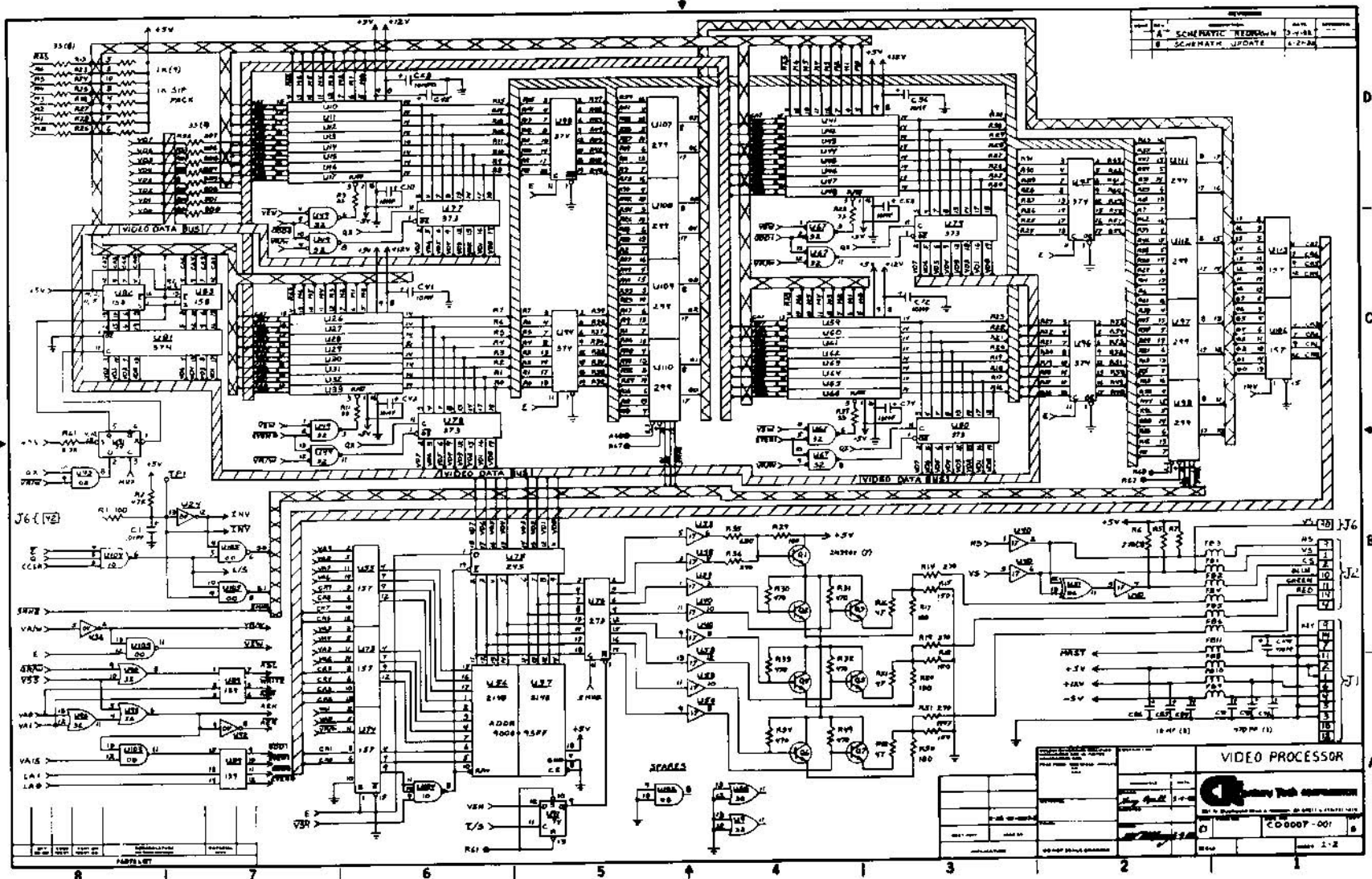

Video Processor 1/2

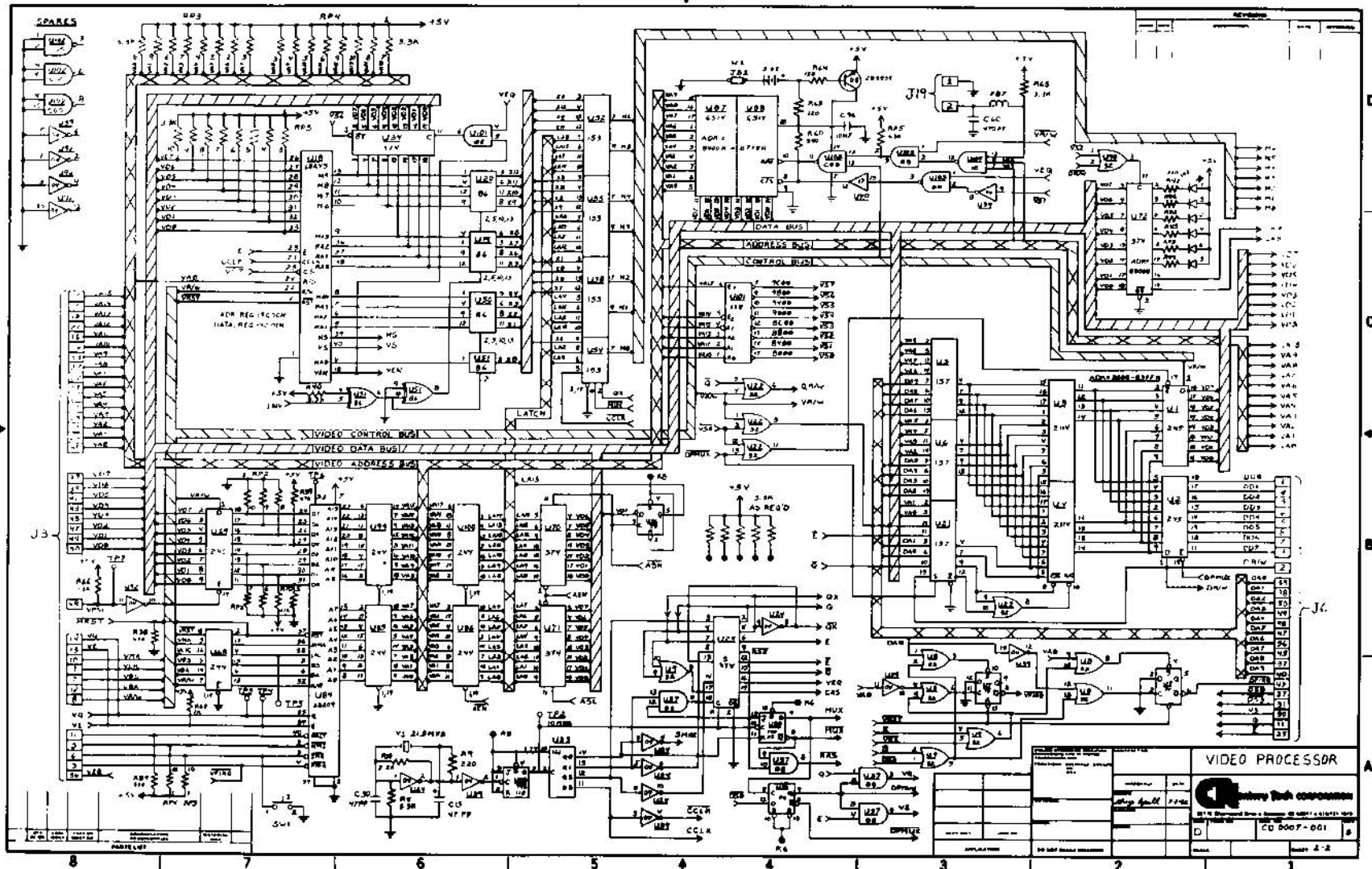

Video Processor 2/2

VIDEO PROCESSOR	
DATE	1978-01-10
DESIGNED BY	J. J. ...
CHECKED BY	...
APPROVED BY	...
PROJECT NO.	CD 0007-001
REV.	1
ISSUE	...
DATE	...
BY	...
APP. BY	...
DATE	...

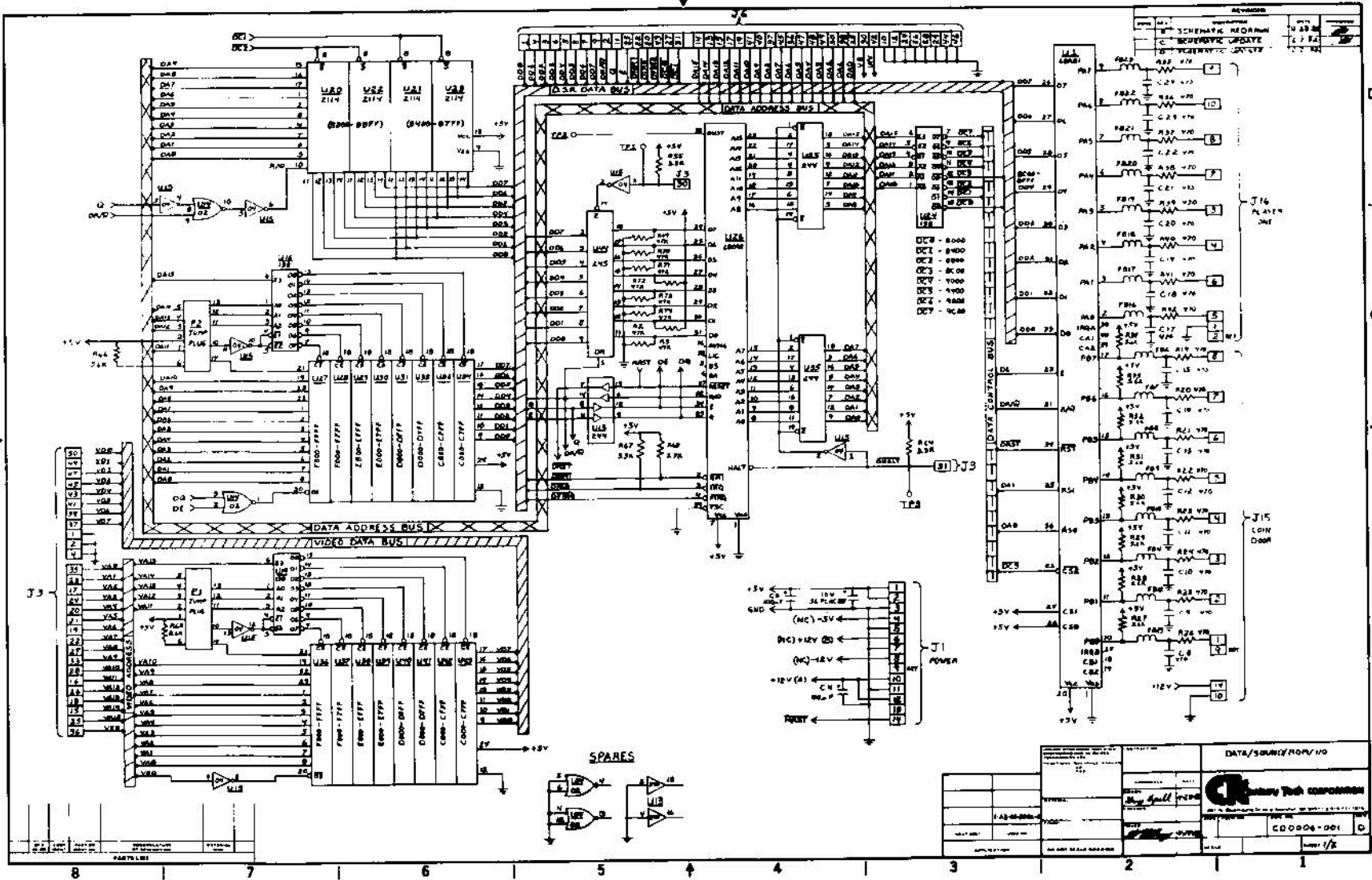

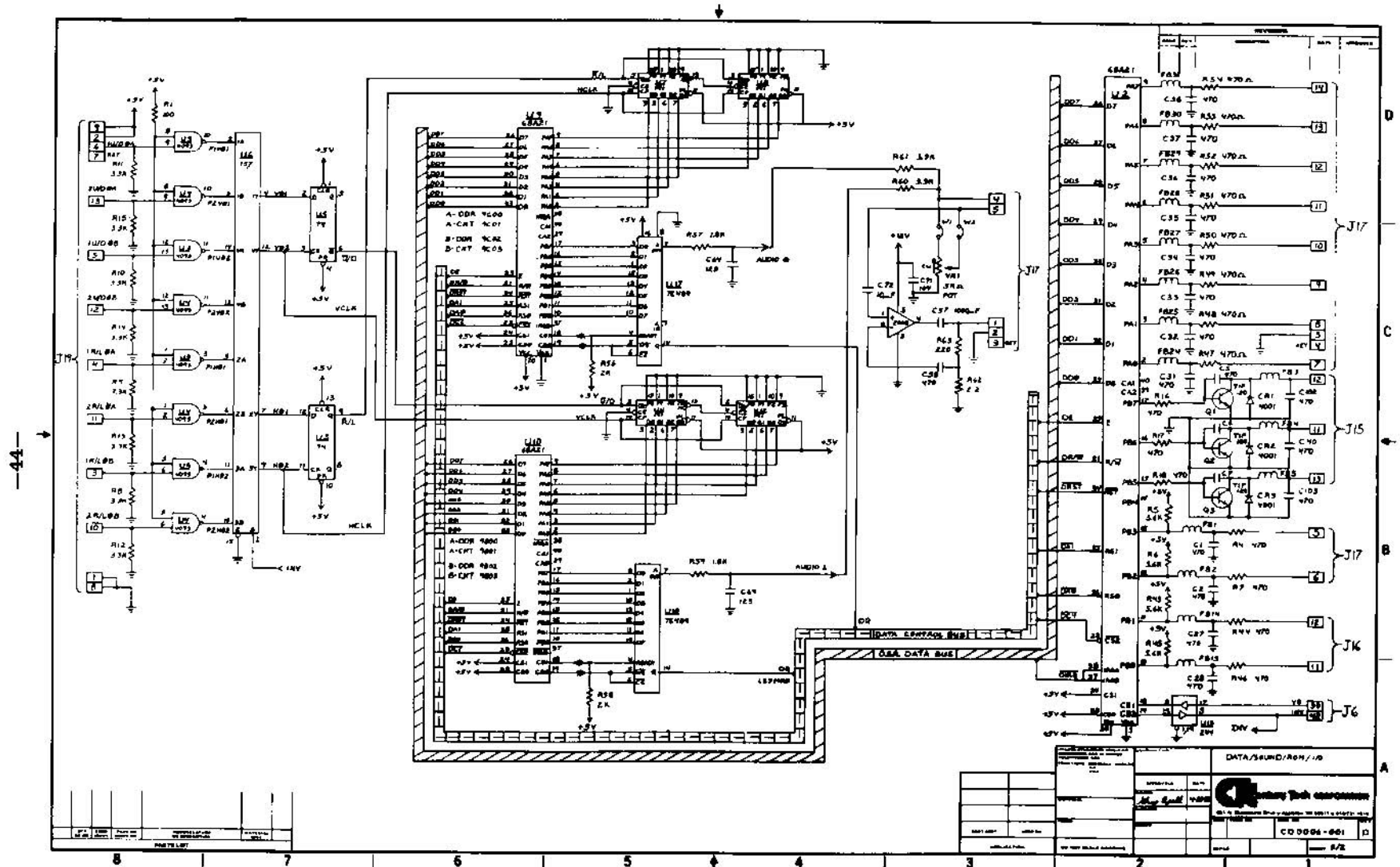

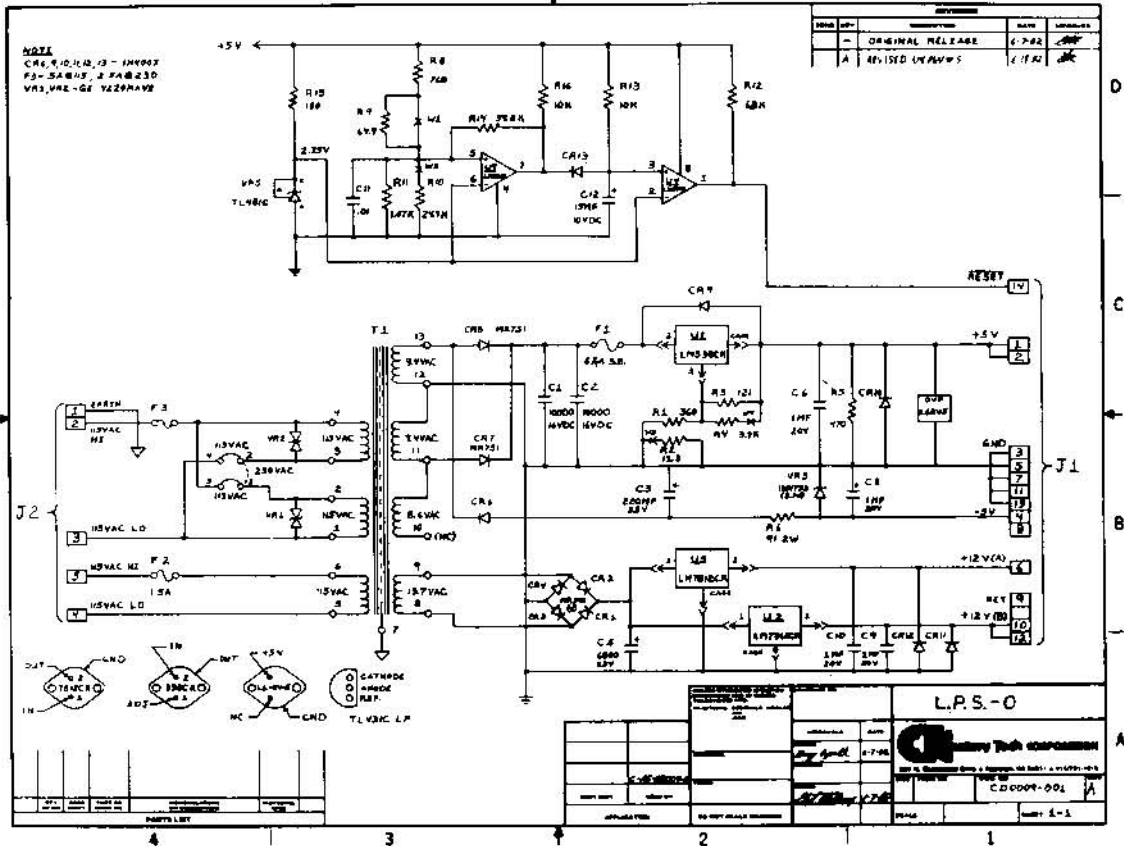

Power Supply Schematic

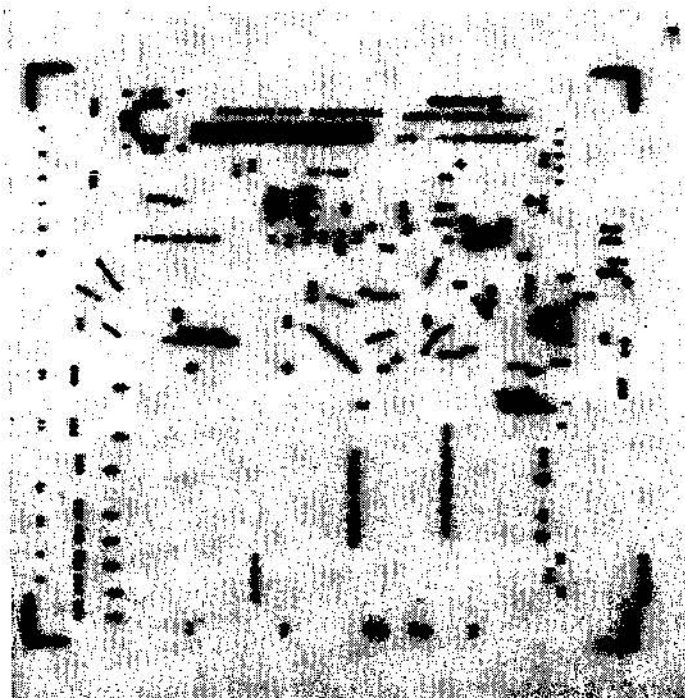

Power Supply Layout

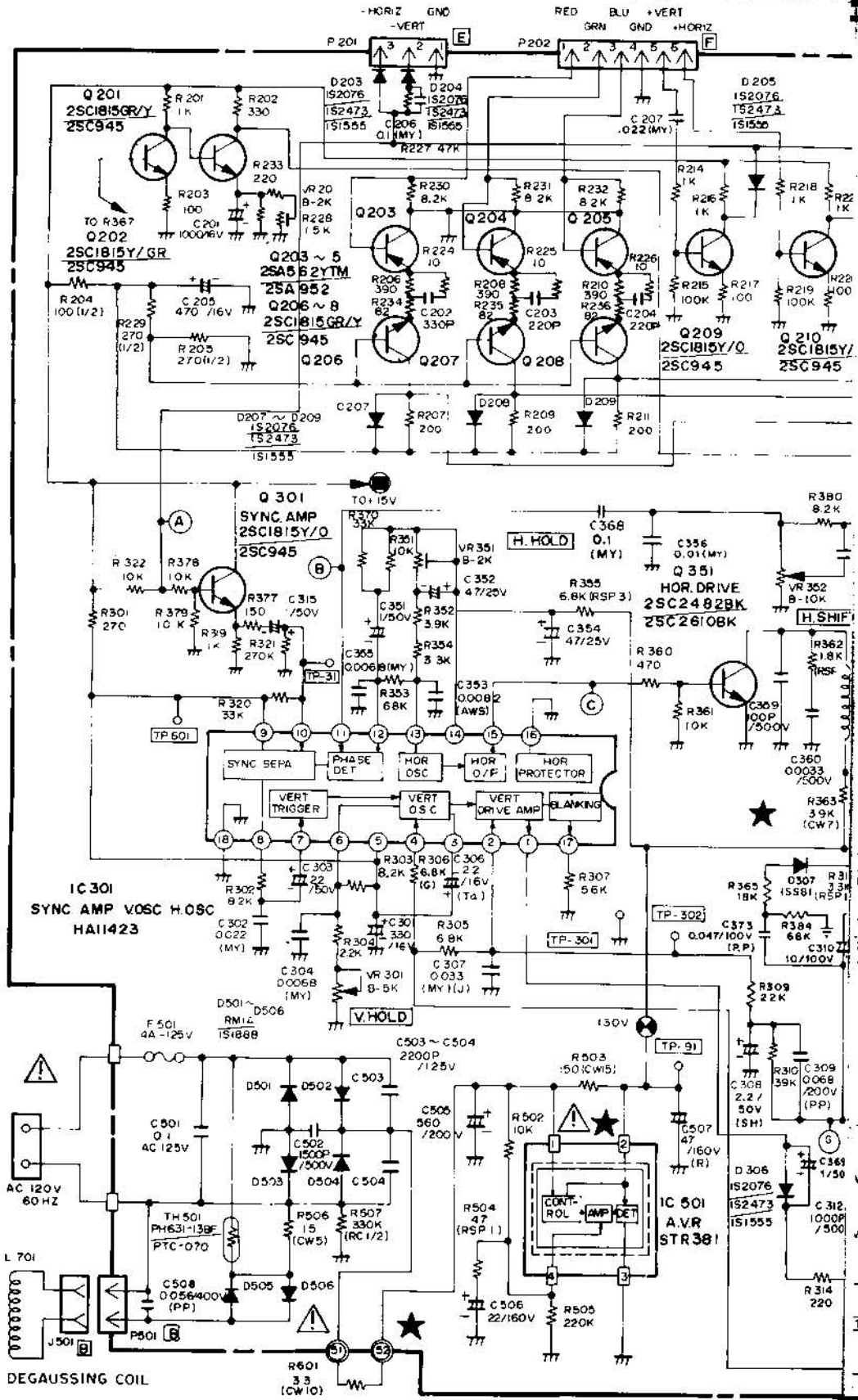

GAME MONITOR SCHEMATIC DIAGRAM

