

Turkey SHOOT™

SERVICE MANUAL

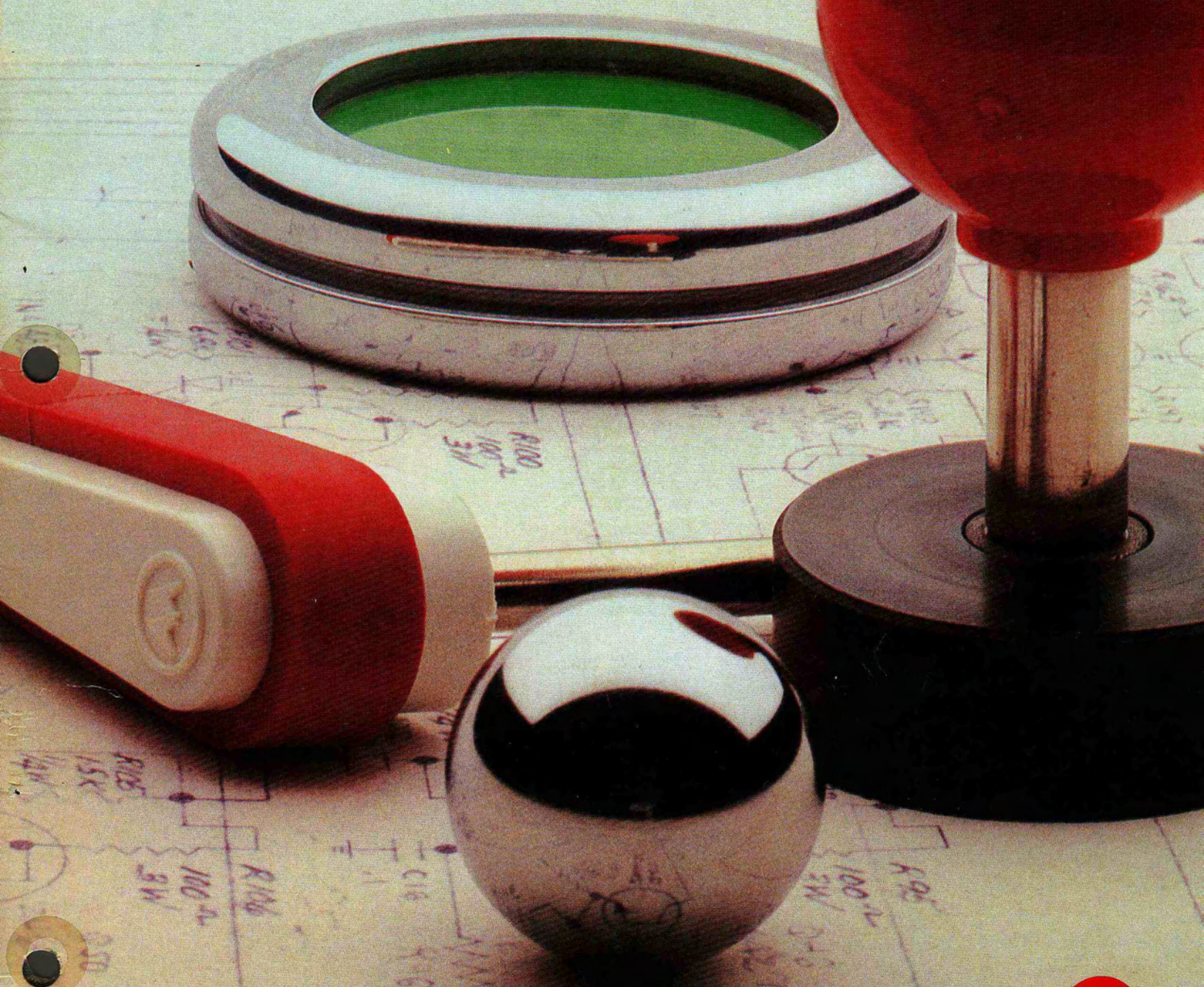

Williams®



ROM SUMMARY

ROM	PART NO.	DESCRIPTION	IC NO.	BOARD	ERROR CODE OR INDICATION
Sound ROM	A-5343-10706	2764 PROM, 8Kx8	IC8	CPU	no sound
TURKEY SHOOT 2	A-5343-10707	2732 PROM, 4Kx8	IC9	CPU	feathers
TURKEY SHOOT 3	A-5343-10708	2732 PROM, 4Kx8	IC10	CPU	spkr clicks
TURKEY SHOOT 4	A-5343-10709	2764 PROM, 8Kx8	IC11	CPU	213
TURKEY SHOOT 5	A-5343-10710	2764 PROM, 8Kx8	IC12	CPU	209
TURKEY SHOOT 6	A-5343-10711	2764 PROM, 8Kx8	IC13	CPU	205
TURKEY SHOOT 7	A-5343-10712	2764 PROM, 8Kx8	IC14	CPU	201
TURKEY SHOOT 8	A-5343-10713	2764 PROM, 8Kx8	IC15	CPU	214
TURKEY SHOOT 9	A-5343-10714	2764 PROM, 8Kx8	IC16	CPU	210
TURKEY SHOOT 10	A-5343-10715	2764 PROM, 8Kx8	IC17	CPU	206
TURKEY SHOOT 11	A-5343-10716	2764 PROM, 8Kx8	IC18	CPU	202
TURKEY SHOOT 12	A-5343-10717	2764 PROM, 8Kx8	IC19	CPU	215
TURKEY SHOOT 13	A-5343-10718	2764 PROM, 8Kx8	IC21	CPU	207
TURKEY SHOOT 14	A-5343-10719	2764 PROM, 8Kx8	IC23	CPU	216
TURKEY SHOOT 15	A-5343-10720	2764 PROM, 8Kx8	IC24	CPU	none
TURKEY SHOOT 16	A-5343-10721	2764 PROM, 8Kx8	IC25	CPU	208
TURKEY SHOOT 17	A-5343-10722	2764 PROM, 8Kx8	IC26	CPU	204
Special Chip 2	A-5410-10083	Special Chip	IC29	CPU	—
Special Chip 2	A-5410-10083	Special Chip	IC30	CPU	—
Clock-ROM 1	A-5282-10295	82S123 ROM, 32x8	IC14	VIDEO	no video
TURKEY SHOOT 21	A-5343-10726	2764 PROM, 8Kx8	IC41	VIDEO	vert lines
Horiz-sync ROM 1	A-5282-10294	82S129 ROM, 256x4	IC47	VIDEO	—
TURKEY SHOOT 18	A-5343-10723	2732 ROM, 4Kx8	IC55	VIDEO	gobbles
TURKEY SHOOT 19	A-5343-10724	2764 PROM, 8Kx8	IC57	VIDEO	vert lines
TURKEY SHOOT 20	A-5343-10725	2764 ROM, 8Kx8	IC58	VIDEO	vert lines
Decoder-ROM 5A (Horizontal)	A-5282-10292	6349 ROM, 512x8	IC60	VIDEO	—

CPU-BOARD JUMPERS: W1, W3, W6, W8, W10, W11, W14 and W16. Remove jumper W11 for cocktail games.

TURKEY SHOOT is a trademark of **WILLIAMS ELECTRONICS, INC.**
© 1984 **WILLIAMS ELECTRONICS, INC.**

NOTICE

TO ORDER REPLACEMENT ROMS from your authorized **WILLIAMS** distributor, specify (1) part number shown above, (2) ROM-label color, (3) REV level (number) on the label, and (4) which game the ROM is used in.



SERVICE MANUAL

- **schematic and logic diagrams**
- **operation**
- **bookkeeping**
- **adjustment**
- **diagnostics**
- **parts**

Contents

ROM Summary	2
Warnings & Notices	5
Examine Your Game	5
Control Locations	5
Power Turn-On	5
Game Operation	6
Bookkeeping Totals	6
Exclusive Game-Adjustments	7
Game Pricing	8
Diagnostic-Mode Tests	8
Built-In Test Procedures	9
Sound Self-Test	10
A Word About Troubleshooting	10
Interboard Wiring	11
CPU-Board Bill of Materials	12
CPU-Board Assembly Drawing	13
CPU-Board Logic Diagram (Sheet 1 of 2)	14
CPU-Board Logic Diagram (Sheet 2 of 2)	15
Video-Board Bill of Materials	16
Video-Board Assembly Drawing	17
Video-Board Logic Diagram (Sheet 1 of 2)	18
Video-Board Logic Diagram (Sheet 2 of 2)	19
D-8784 Power-Supply Assembly Drawing	20
D-8784 Power-Supply Schematic Diagram	21
Interface-Board Assembly Drawing	22
Interface-Board Schematic Diagram	23
Power-Wiring Diagram	24
Cabinet and Control-Panel Wiring Diagram	26
Opto-Board Assembly Drawing and Schematic Diagram	28
Gun Parts	29
Feather-Chamber Parts	30
Turret-Assembly Parts	31
Male Connectors and Female Receptacles	33

Warnings & Notices

WARNING

FOR SAFETY AND RELIABILITY, WILLIAMS does not recommend or authorize any substitute parts or modifications of **WILLIAMS** equipment.

USE OF NON-WILLIAMS PARTS and modifications of game circuitry may adversely affect game play, or may cause injuries.

SUBSTITUTE PARTS OR EQUIPMENT MODIFICATIONS may void FCC type-acceptance.

SINCE THIS GAME IS PROTECTED by Federal copyright, trademark and patent laws, unauthorized game-conversions may be illegal under Federal law.

THIS "CONVERSION" PRINCIPLE ALSO APPLIES to unauthorized facsimiles of **WILLIAMS** equipment, logos, designs, publications, assemblies and games (or game features not deemed to be in the public domain), whether manufactured with **WILLIAMS** components or not.

RF-INTERFERENCE NOTICE

CABLE PLACEMENT and ground-strap routing on this game have been designed to keep RF radiation and conduction within levels accepted by FCC regulations.

TO MAINTAIN THESE LEVELS, reposition harnesses and reconnect ground straps to their original placements if they should be disconnected during maintenance.

Examine Your Game

INSPECT THE OUTSIDE of the carton or game cabinet for shipping damage.

UNLOCK AND OPEN the bottom-rear door. Now check circuitry.

ARE CONNECTORS SECURELY ATTACHED? Reconnect any found loose. DON'T FORCE CONNECTORS. They're keyed and only fit one way.

ARE PLUG-IN CHIPS FIRMLY SEATED in their sockets?

UNWRAP THE POWER CORD coiled inside the cabinet. DON'T PLUG IT IN YET!

SCRUTINIZE MAJOR SUBASSEMBLIES, such as the monitor, control panel, transformer chassis and power supply. Make sure they're securely-mounted.

UNDO THE CONTROL-PANEL LATCHES. You can reach these two from the coin door by extending your arm upward and to either side. Now check connectors and circuitry as above.

Control Locations

THE ON-OFF SWITCH is below the back door.

THE POWER-INTERLOCK SWITCH is behind the bottom-right corner of the back door. The interlock switch is a spring-loaded DPDT type that will turn off the game when you remove the panel. For servicing purposes, pull the switch out and the game will power up.

THE VOLUME-CONTROL is inside the coin-door and to your right.

THREE DIAGNOSTIC SWITCHES are mounted together on a bracket behind the coin door. *These switches are used to access the Diagnostic-Mode Tests, the BOOKKEEPING TOTALS screen and the GAME ADJUSTMENTS screen.*

THE MEMORY-PROTECT INTERLOCK SWITCH is behind the coin door. This switch must be open when you clear BOOKKEEPING TOTALS or make GAME ADJUSTMENTS. It automatically opens when the coin door is open.

THE CPU-BOARD RESET SWITCH is on the CPU board near the batteries.

THE CASHBOX ADVANCE-SWITCH found inside the cashbox door allows bookkeeping information to be audited without permitting it to be zeroed.

THE SOUND DIAGNOSTIC-SWITCH is on the CPU board near the small heatsink. Refer to **Sound Self-Test** for information on its use.

Power Turn-On

WARNING

THREE-WIRE PLUG. This game must be plugged into a properly-grounded outlet to prevent shock hazard and to assure proper game operation. DO NOT use a "cheater" plug to defeat the ground pin on the power cord, and DO NOT cut off the ground pin.

WARNING

FCC STICKER. Check the back of your game to see that an FCC sticker was attached to your game at the factory. All games that leave **WILLIAMS'** plants have been tested and found to comply with FCC Rules. As the sticker is proof of this fact, *legal repercussions to the owner and distributor of the game* may result if the sticker is missing. If you receive any **WILLIAMS** game (manufactured after December 1982) that has no FCC sticker, call **WILLIAMS** for advice or write us a note on your game-registration card. *Be sure the card bears your game's serial number.*

WHEN THE GAME IS FIRST TURNED ON general illumination should light. A moment later the scanning "rug pattern" indicating RAM/ROM test should appear on the screen.

IN A CORRECTLY-RUNNING GAME tests will be followed by the message "INITIAL CHECKS INDICATE ALL SYSTEMS GO." If failure messages come up on the screen instead, refer to **Built-In Test Procedures.**

DEMAGNETIZE THE GAME with a television degaussing-coil. Besides the monitor, remember to degauss large steel parts (for example, the back-door hinge). Do this as a daily procedure. *Otherwise residual magnetism may cause color impurities that adversely affect your collections.*

WARNING

This equipment generates, uses, and can radiate radio frequency energy and if not installed and used in accordance with the instructions manual, may cause interference to radio communications. It has been tested and found to comply with the limits for a Class A computing device pursuant to Subpart J of Part 15 of FCC Rules, which are designed to provide reasonable protection against such interference when operated in a commercial environment. Operation of this equipment in a residential area is likely to cause interference in which case the user at his own expense will be required to correct the interference.

Game Operation

GAME START

INSERT COINS. The game allocates an adjustable number of credits per coin and displays this number on the CRT. Factory settings are one credit for two quarters. At factory settings, when two credits are displayed, pressing 2-PLAYER START initiates a two-player game.

PLAYER CONTROLS

- SHOOT** mischievous turkeys with the laser gun.
- PRESS GOBBLE!** Freeze the turkeys and pick them off with the gun!

- PRESS GRENADE!** Eliminate several turkeys in one blast!

GAME PLAY

WITH A HAND ON HIS GUN, his GOBBLE and GRENADE buttons at the ready, the player defends his territory from marauding TURKEYS! He's given 100 missions to eliminate all the turkeys.

HE CAN TAKE AIM with his laser gun using the cursor on the screen to home in on his enemies. Or he can launch a GRENADE to blast all turkeys within range. Once each mission he can activate his GOBBLE button to momentarily freeze all the turkeys.

ASTUTE PLAYERS learn that most turkeys can be eliminated by a shot to the body. However the cyborg mechano-turkey persists until they hit him in the head. No turkey will succumb to a shot in the leg!

MISSIONS REQUIRE QUICK REACTIONS to clever plays such as turkey air-raids, turkeys disguising themselves as businessmen and turkey helicopter-getaways. Every 8th wave earns a rapid-fire bonus where the player has 15 seconds to eliminate as many turkeys as possible. The player can score bonus points by shooting fire hydrants and trashcans as well as by freeing hostages.

THREE FOWLUPS are allowed. These occur whenever a turkey escapes or when an innocent bystander is injured.

Bookkeeping Totals

BOOKKEEPING TOTALS SHOW YOU AT A GLANCE if game settings are bringing you a satisfactory return on your investment! *Only games by WILLIAMS ELECTRONICS have this feature.* Think of it as a unique way to keep your **TURKEY SHOOT** game the leader of the pack when it comes to earnings...location after location, week in and week out!

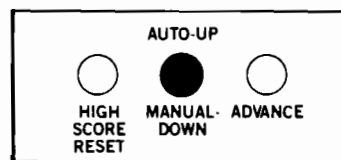

Diagnostic Button-Switches

ENTERING BOOKKEEPING MODE. Inside the coin door is a bracket with three button-switches. Set the AUTO-UP/MANUAL-DOWN (center) switch to AUTO-UP. Press the ADVANCE switch to display BOOKKEEPING TOTALS on the screen. Now check those totals. Here's what to look for...

BOOKKEEPING TOTALS

LEFT SLOT COINS	432
CENTER SLOT COINS	0
RIGHT SLOT COINS	398
PAID CREDITS	830
EXTRA MISSIONS EARNED	226
TOTAL PLAY TIME (HOUR: MIN)	34:28
TOTAL MEN PLAYED	689
TOTAL SINGLE PLAYER	548
TOTAL TWO PLAYER	141
TOTAL CREDITS PLAYED	830
AVERAGE TIME/GAME (MIN:SEC)	2:00

Bookkeeping screen

AVERAGE TIME PER CREDIT: TWO MINUTES. Your most important figure on the BOOKEEPPING TOTALS screen is AVERAGE TIME/GAME. You'll want to pay special attention to this figure every day for this reason: Thorough field and factory research has shown that *two-minute games both satisfy players and also keep the quarters flowing.*

If games aren't running about two minutes long, then collections probably aren't at their peak. You'll want to tailor your game to your game-playing public. It's easy. But **only WILLIAMS games let you do it!**

Exclusive Game Adjustments

1. Inside the coin door is a bracket with three button switches. Set the AUTO-UP/MANUAL-DOWN (center) switch to AUTO-UP.
2. Press the ADVANCE switch twice. The GAME ADJUSTMENTS screen will come up.
3. Use PLAYER 2 START to move down to the desired adjustment.
4. Use PLAYER 1 START to move up.
5. Use GOBBLE (*raise value or yes*) or GRENADE (*reduce value or no*) to alter the value of an adjustment.

GAME ADJUSTMENTS

EXTRA FOWL EVERY	5000	RECOMMENDED
MISSIONS FOR 1 CREDIT GAME	3	RECOMMENDED
ATTRACT MODE SOUNDS	YES	
PRICING SELECTION	5	1/FIFTY 2/DOLLAR
LEFT SLOT UNITS	1	
CENTER SLOT UNITS	4	
RIGHT SLOT UNITS	1	
UNITS REQUIRED FOR CREDIT	2	
UNITS REQUIRED FOR BONUS CREDIT	0	
MINIMUM UNITS FOR ANY CREDIT	0	
DIFFICULTY OF PLAY	5	RECOMMENDED
GUN RECOIL	YES	
RESTORE FACTORY SETTINGS	NO	
CLEAR BOOKKEEPING TOTALS	NO	
HIGH SCORE TABLE RESET	NO	
AUTO CYCLE	NO	

(PLAYER 1 START) TO MOVE UP - (PLAYER 2 START) TO MOVE DOWN
 (GOBBLE) TO INCREASE VALUE - (GRENADE) TO DECREASE VALUE
 PRESS ADVANCE TO EXIT

Adjustments Screen Showing Factory Settings

Pricing Table

COIN-DOOR MECHANISM	GAMES/PRICE	PRICING SELECTION	LEFT SLOT UNITS	CENTER SLOT UNITS	RIGHT SLOT UNITS	UNITS REQ'D FOR CREDIT	UNITS REQ'D FOR BONUS CREDIT	MIN. UNITS FOR ANY CREDIT
Twin-Quarter or Quarter, Dollar, Quarter	•1/25¢, 4/\$1	3	1	4	1	1	0	0
	1/25¢, 5/\$1	0	1	4	1	1	4	0
	2/50¢, 4/\$1	0	1	4	1	1	0	2
	2/50¢, 5/\$1	0	1	4	1	1	4	2
	•1/50¢, 2/\$1	5	1	4	1	2	0	0
	1/50¢, 3/\$1, 4/\$1.25	0	3	12	3	4	15	0
	1/\$1	0	1	4	1	4	0	0
	1/50¢, 3/\$1, 7/\$2	0	12	48	12	14	96	24
1DM, 5DM	2/1DM, 12/5DM	0	12	0	2	2	0	0
	•1/1DM, 6/5DM	2	6	0	1	1	0	0
1Franc, 5 Franc	•1/2F, 3/5F only	4	1	16	6	2	0	0
25-Cent, 1 Guilder,	•1/25¢, 4/1G	6	1	0	4	1	0	0
	1/25¢, 5/1G	0	1	0	4	1	4	0
5-Franc, 10 Franc	•1/5F, 2/10F	7	1	0	2	1	0	0
	•1/10F	8	1	0	2	2	0	0
1 Franc, 2 Franc	•2/1F, 5/2F	2	6	0	1	1	0	0
100 Lire, 200 Lire	•1/200 Lire	8	1	0	2	2	0	0
Twin Coin	•1/1 Coin	3	1	4	1	1	0	0
	•1/2 Coins	5	1	4	1	2	0	0
	1/4 Coins	0	1	4	1	4	0	0
	1/2 Coins, 3/4 Coins	1	1	4	1	2	4	0
	1/3 Coins, 2/5 Coins	0	2	0	2	5	0	0
1-Unit, 5-Unit	•1/2, 3/5	4	1	16	6	2	0	0
	1/1, 5/5	0	1	0	5	1	0	0
	1/3, 2/5	0	2	0	10	5	0	0
Any	Free Play	9	1	4	1	1	0	0

Now for the multiple-choice section! Choose one or more:

Use **GOBBLE** or **GRENADE** to choose the appropriate difficulty level (0 = easiest or extra liberal, 5 = average, 9 = hardest or extra conservative).

SELECT GAME PRICING with standard or custom settings. See the *Pricing Table*.

Game Pricing

PRICING SELECTION allows a *shorthand* method of setting the pricing functions. If a number from one to nine is entered into the PRICING SELECTION function, a corresponding standard setting (shown in the pricing table above) will be entered into the game. *The rest of the pricing functions are automatically set for that standard.*

FOR CUSTOM SETTINGS first set PRICING SELECTION to zero. Then set the remaining values according to the *Pricing Table*.

THE GAMES : PRICE RATIO is equivalent to the ratio X : VC, where:

X = SLOT UNITS
V = COIN VALUE
C = UNITS REQUIRED FOR CREDIT

For example at factory settings with quarter chutes the variables produce 1 : 25x2 or one game for two quarters.

Diagnostic-Mode Tests

SET THE AUTO-UP MANUAL-DOWN SWITCH to the MANUAL-DOWN position and press ADVANCE. The game is now in its **Diagnostic Mode** and a ROM test is performed. With ROM test results present on the CRT display, set the AUTO-UP/MANUAL-DOWN switch to the AUTO-UP position. Enter subsequent tests by pressing ADVANCE once more for each test. After the last test, **Game-Over Mode** commences.

AUTO-CYCLE MODE permits continuous ROM, RAM and CMOS RAM tests to detect failures that only appear after numerous checksum comparisons. If an error is detected **Auto-Cycle Mode** is aborted and a failure message is displayed on the CRT.

1. Open the coin door. It must remain open for AUTO CYCLE.
2. Display GAME ADJUSTMENTS.
3. Move down to AUTO CYCLE.
4. Display YES.
5. Press ADVANCE.
6. To enter **Game-Over Mode** turn the game off and on.

Built-In Test Procedures

POWER-UP TESTS

RAM TEST. A *rug pattern* scans across the screen. Only screen RAMS (dynamic type) are tested. A bad RAM is indicated on the CPU-board LED-indicator by an error code between 100 and 199 (eg., 1-3-1; see the table of **Screen-RAM Error Codes** below).

If a RAM error is indicated, check all three DC power-voltages on the RAM indicated: -5/pin 1, +12/pin 8, +5/pin 9. None of these should have more than a few millivolts of AC on it. *Never replace a RAM chip until you prove that these voltages are normal!*

Screen-RAM Error Codes

CHIP	98	99	100	101	102	103	104	105
CODE	115	116	117	118	111	112	113	114
CHIP	106	107	108	109	110	111	112	113
CODE	125	126	127	128	121	122	123	124
CHIP	114	115	116	117	118	119	120	121
CODE	135	136	137	138	131	132	133	134

ROM TEST. A bad ROM is indicated on the CPU-board LED-indicator by an error code between 200 and 299 (eg., 2-1-1; see the **ROM Summary** for codes). An error message may also appear on the CRT. Power down and replace bad chips.

CMOS-DATA TEST. Checksums are compared. If the CMOS RAM fails the test, **FACTORY SETTINGS RESTORED** appears on the CRT.

DIAGNOSTIC-MODE TESTS

RAM AND ROM TESTS... These tests are repeated, only the ROM test is performed first. Refer to **RAM Test** and **ROM Test** above.

CMOS-RAM TEST. A chip error is displayed on the CRT and the LED readout on the CPU board. If the CMOS RAM is bad, the error code 3 will appear on the LED readout.

SOUND, COIL AND LAMP TEST. Sound-lines 1 through 6 are tested. In addition, the grenade and gun lamps, feather and gun coils are checked.

One by one, sound lines, lamps or coils are pulsed. *When a sound line is pulsed*, its number is shown on the CRT. You should hear a separate sound for each sound line. If a sound is missing, its corresponding line is probably *stuck high* or *stuck low*. If two lines produce the same sound, they're shorted together.

Use AUTO-UP to cycle through all the sounds, coils and lamps. With MANUAL-DOWN, you'll continuously test one sound-line, lamp or coil.

SWITCH TEST. The name of the switch is highlighted when that switch is closed. Opto switches (used to determine gun position) are tested in a special way: Watch the graph on the left side and bottom of the switch-test screen as you move the gun. The graph should change color ("move") smoothly.

If the graph appears to "jump," adjust the optos for smooth movement. *To exit the Switch Test you must hold ADVANCE down until the next screen appears.*

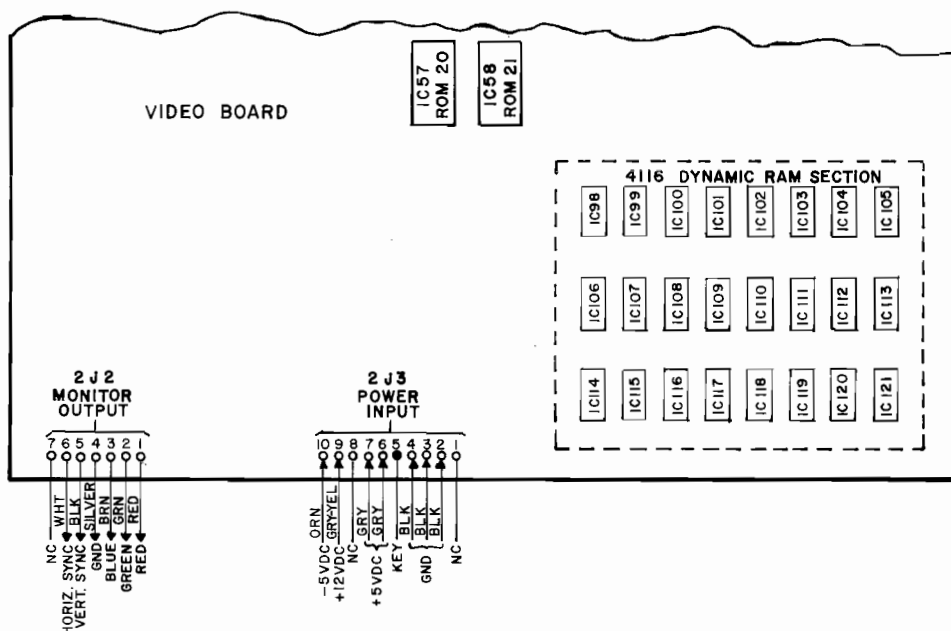

□ **THE CROSSHATCH PATTERN** aids the technician in converging the monitor.

□ **THE PURITY SCREENS** (solid red, green and blue screens) are intended for monitor adjustments and for checking the color RAMs (*ICs 75 through 78 on the video board*). If these screens show contaminated colors, degauss the monitor and adjust the purity magnets. If colors are missing, one of your color RAMs may be bad.

A purity screen with vertical lines through it also signals a color-RAM error. (*Please don't confuse the purity screens with the crosshatch pattern or color-bars pattern. These last two patterns are supposed to have vertical lines!*)

□ **THE COLOR BARS** are intended for monitor adjustments and for checking the color RAMS. The bars serve as a color and brightness reference when you adjust the color drives and cutoffs, screen and black-level controls.

If colors are missing or the wrong colors are displayed, you may have a bad color RAM. From the left side of the CRT, here are the colors you should see: *red, green, blue, black, white, yellow, cyan and magenta.*

Sound Self-Test

1. **NO SOUND IN DIAGNOSTIC-MODE TEST:** Check the sound-select inputs (pins 2 through 9 of IC 4) on the CPU board for pulsing during the test. Also check for shorts between sound lines.
2. **STILL NO SOUND:** Turn the volume control all the way up. With the game turned on, momentarily place a powered-up AC soldering-pencil on the center tap of the volume control. DO NOT use a soldering iron of over 40 watts. Cordless models will NOT work here.
 - A. **If you hear a low hum,** the power-amplifier chip (TDA2002A), volume control and speaker are okay.

B. **If you don't hear a hum,** try the test again with the volume control turned halfway up.

3. **GARBLED SOUNDS:** One at a time, replace microprocessor IC 27 and sound ROM IC 8 on the CPU board.
4. **THE SOUND DIAGNOSTIC BUTTON** on the CPU board isn't used in this game. If you accidentally press this button, game sounds will be disabled until you turn the game off and on again.

A Word About Troubleshooting

WILLIAMS PROVIDES EXTENSIVE DIAGNOSTICS in the games it manufactures. These can be a dramatic timesaver in your servicing work. Familiarity with the drawing set and instruction manual can also enhance troubleshooting. In the few instances when you can't find the problem using built-in diagnostics, these rules of thumb should help...

1. **GIVE YOUR GAME A VISUAL INSPECTION** in the suspected area. Bad connections are common in older games.
2. **THINK OVER THE SYMPTOMS** and then jot them down. Keeping notes pins down the details of your problem and prevents wasted time going over the same tests.
3. **YOUR ANALYSIS SHOULD REVEAL** which tools you need: Multimeter (analog or digital), logic probe, oscilloscope or other diagnostic equipment. Gather your tools.
4. **CHECK YOUR VOLTAGES.** Check regulated and unregulated DC voltages first at the output of the power supply. If any DC voltage is missing check your AC voltage at the fuse (with reference to its return line to the transformer). Use your **Power-Wiring Diagram** and **Interboard-Wiring Diagram** to find the fuse's location.
5. **SWAP INTERCHANGEABLE BOARDS** and chips that relate to your problem.
6. **ONCE YOU'VE ISOLATED THE SUSPECTED CIRCUIT** use your logic probe or oscilloscope to test for normal operation.

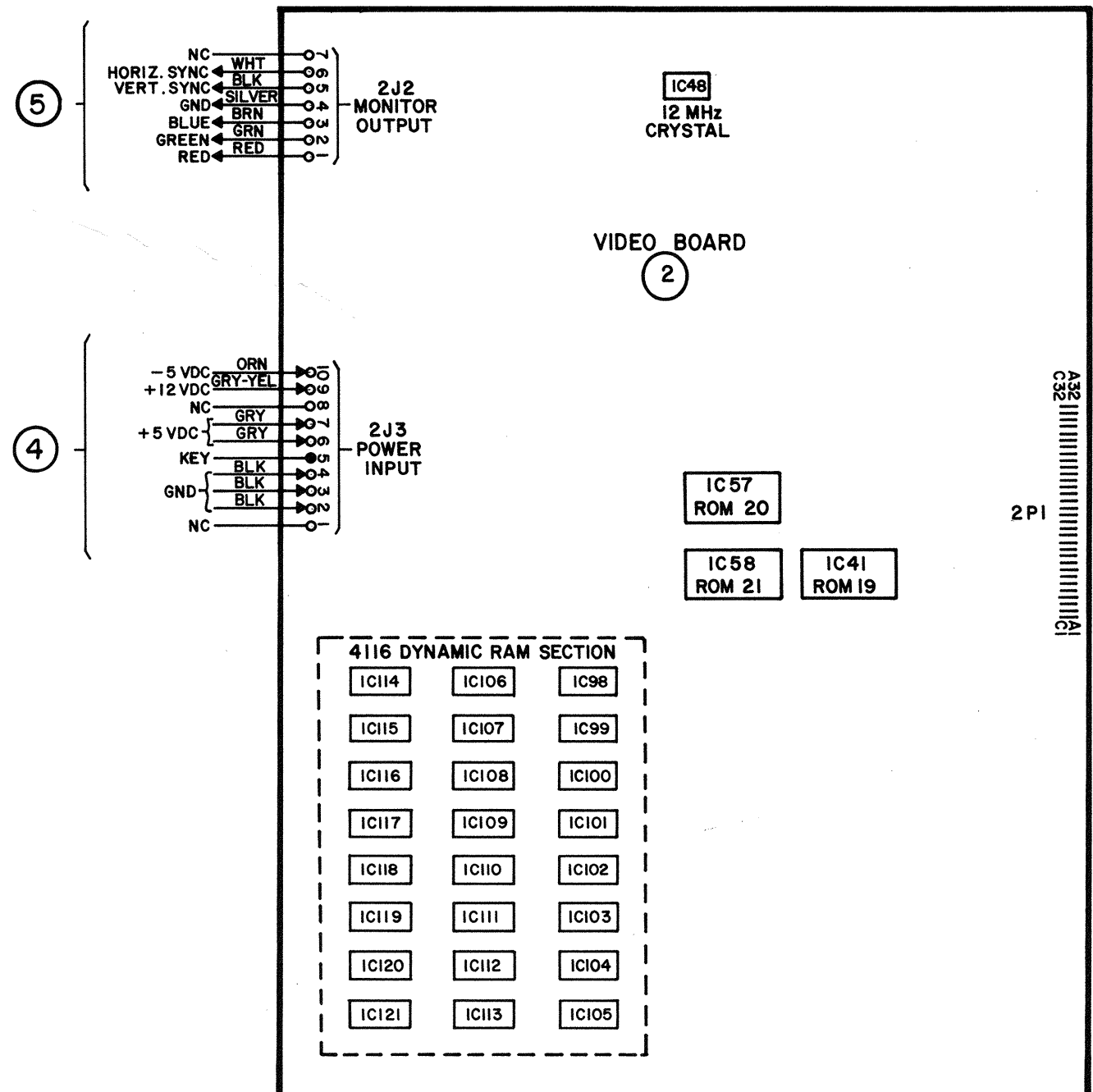
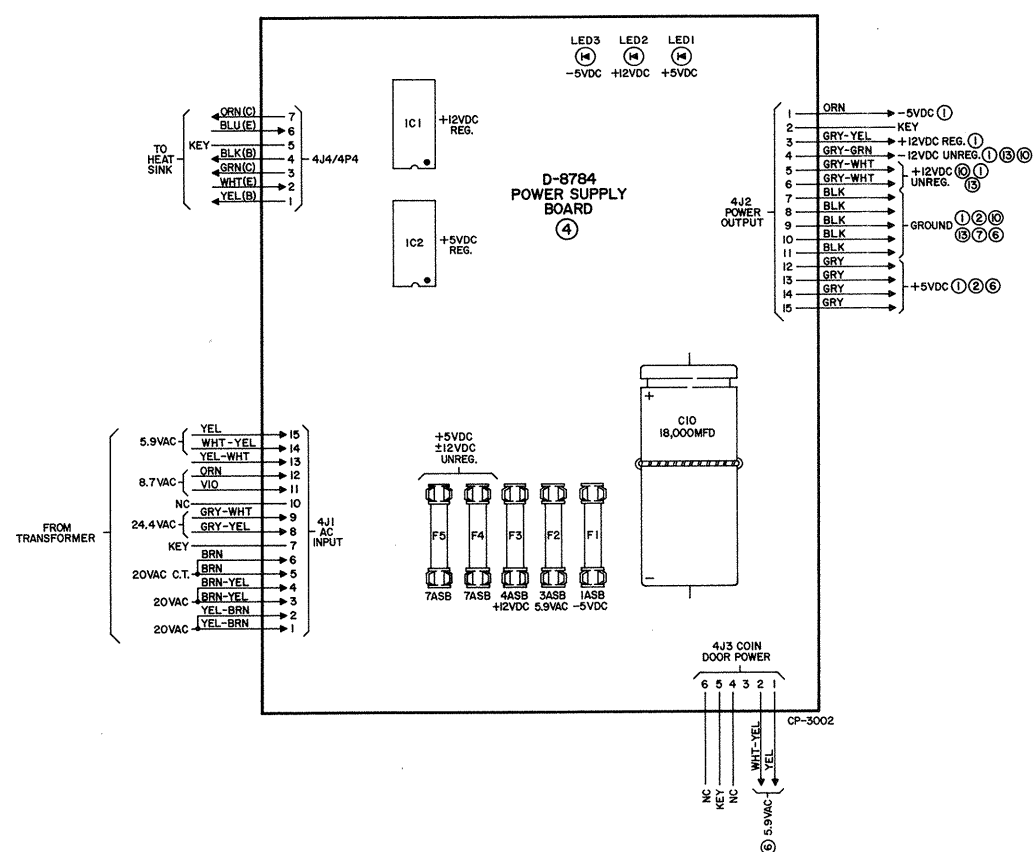
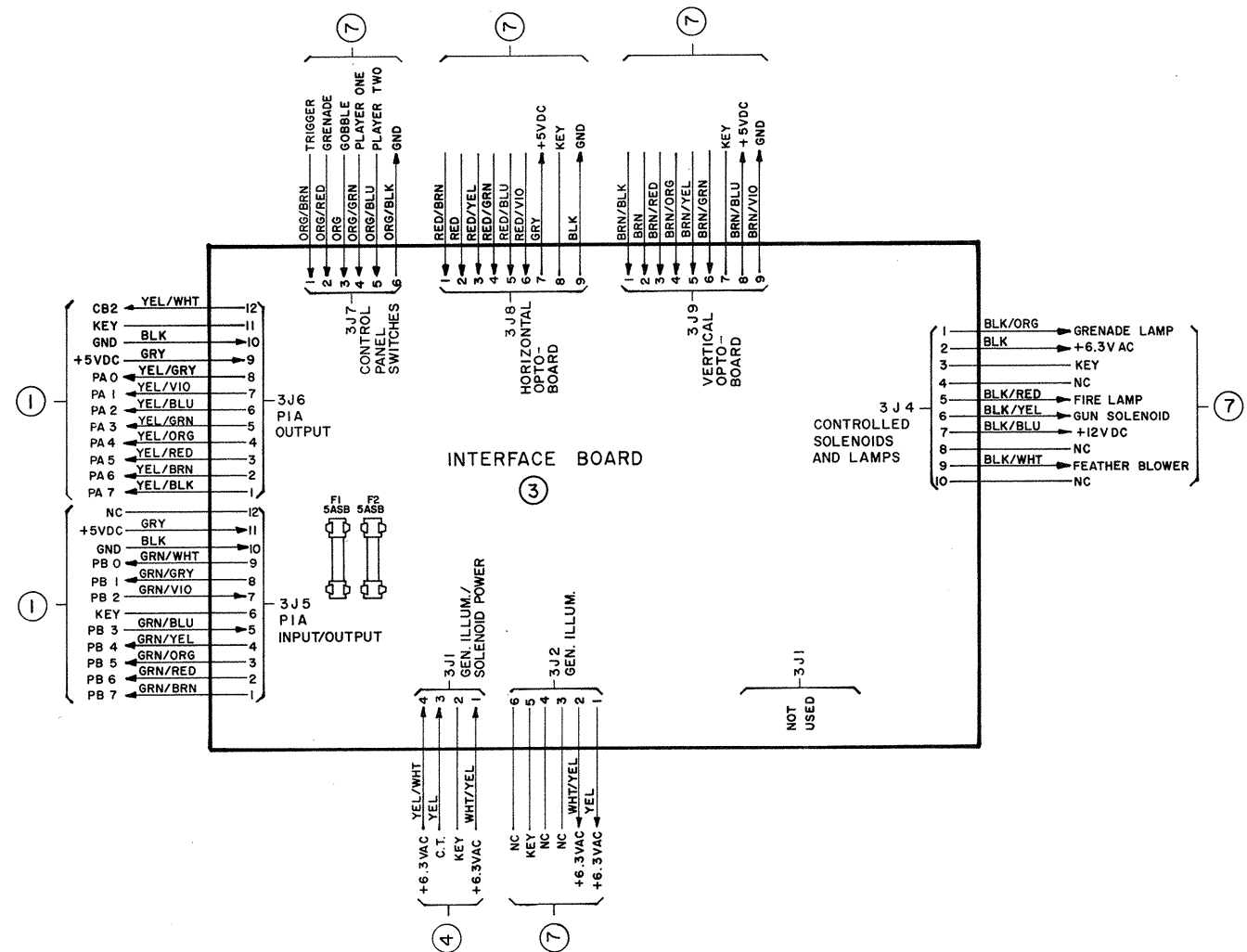

- CONNECTOR KEY**
- 1 CPU BOARD
 - 2 VIDEO BOARD
 - 3 INTERFACE BOARD
 - 4 POWER SUPPLY
 - 5 MONITOR
 - 6 CABINET
 - 7 CONTROL PANEL
 - 8 COIN DOOR
 - 9 CASH BOX
 - 10 VERTICAL OPTO-BOARD
 - 11 HORIZONTAL OPTO-BOARD
 - 12 GUN

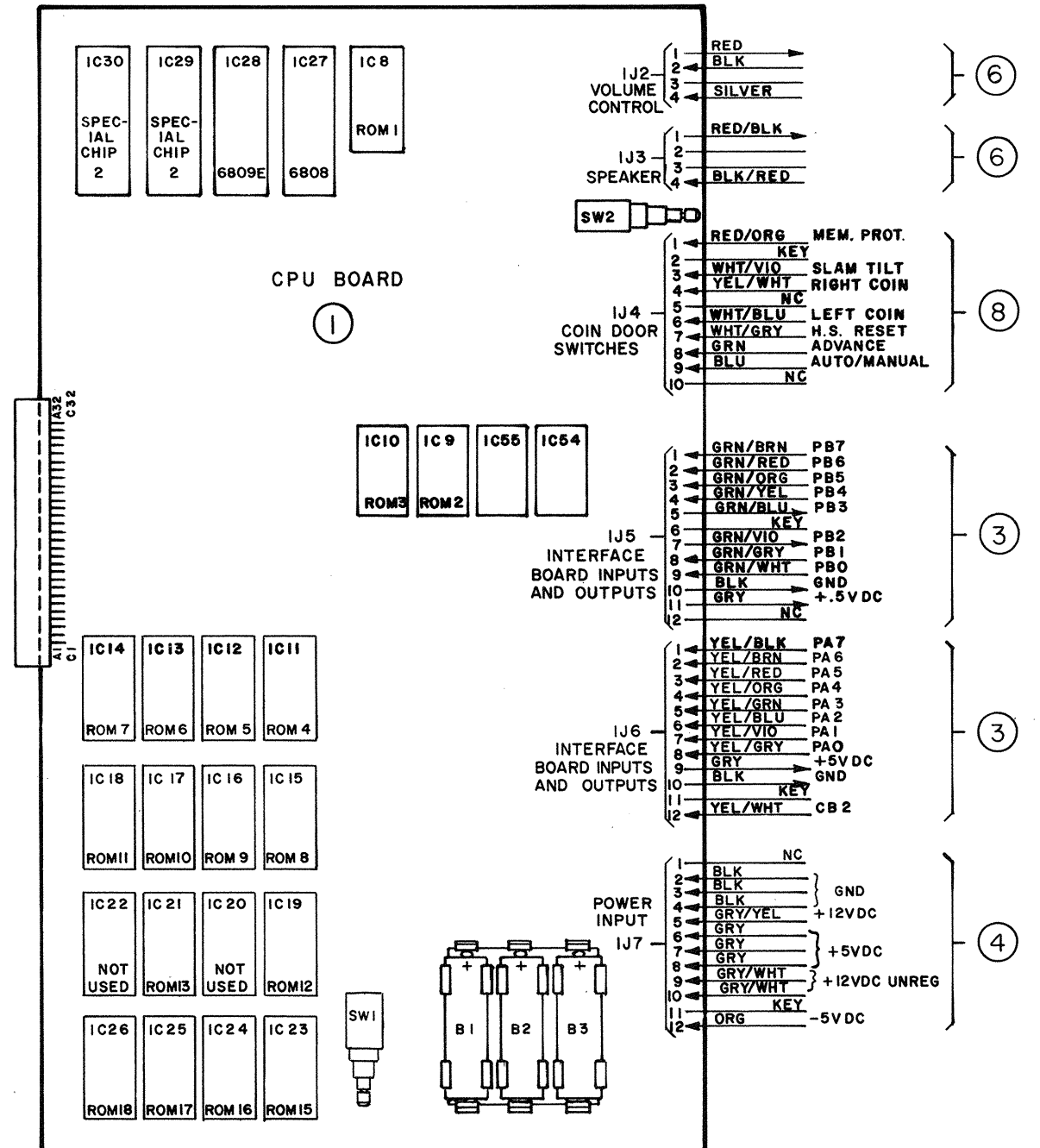

Circuitboards & Gun Mechanism

PART NO.	DESCRIPTION
C-10544	opto PC-board subassembly
C-8809	heatsink assembly
D-9444 or D-8784	power-supply PC-board
D-9868	video PC-board
D-9886	power-transformer chassis
D-10395	CPU PC-board
D-10413	interface PC-board
D-10289	gun mechanism
SFL-24-750-DC	gun coil-assembly
SFL-25-750-DC	feather-dispenser coil

GAME NAME	TURKEY SHOOT
ASSEM. NO.	D-10395
IC8 (ROM1)	A-5343-10706
IC9 (ROM2)	A-5343-10707
IC10 (ROM3)	A-5343-10708
IC11 (ROM4)	A-5343-10709
IC12 (ROM5)	A-5343-10710
IC13 (ROM6)	A-5343-10711
IC14 (ROM7)	A-5343-10712
IC15 (ROM8)	A-5343-10713
IC16 (ROM9)	A-5343-10714
IC17 (ROM10)	A-5343-10715
IC18 (ROM11)	A-5343-10716
IC19 (ROM12)	A-5343-10717
IC20 ---	NOT USED
IC21 (ROM13)	A-5343-10718
IC22 ---	NOT USED
IC23 (ROM14)	A-5343-10719
IC24 (ROM15)	A-5343-10720
IC25 (ROM16)	A-5343-10721
IC26 (ROM17)	A-5343-10722
IC54 ---	NOT USED
IC55 (ROM18)	A-5342-10723
IC29, IC30	A-5410 10083

ITEM NO.	PART NO.	PART DESIGNATION	DESCRIPTION	REQ'D. NO.	ITEM NO.	PART NO.	PART DESIGNATION	DESCRIPTION	REQ'D. NO.	BILL OF MATERIAL				
					ITEM NO.	PART NO.	PART DESIGNATION	DESCRIPTION	REQ'D. NO.	ITEM NO.	PART NO.	PART DESIGNATION	DESCRIPTION	REQ'D. NO.
73	5700-09004-00		24-PIN I.C. SOCKET	4	37	5010-09224-00	SEE NOTE #2	RESISTOR, C.F., 270 OHM 5% 1/4 WATT	8	1	5770-09959-00		BARE P.C. BOARD	1
74	5705-09199-00		HEAT SINK THERMALLOY #6030	1	38	5010-08991-00	R23, R28, R42, R36	RESISTOR, C.F., 4.7 K OHM 5% 1/4 WATT	4	2	5370-09156-00	IC1	I.C., TDA 2002 A AUDIO AMPLIFIER	1
75	4006-01003-06		6-32 X 3/8" P-PH-S	1	39	5010-09416-00	R24	RESISTOR, C.F., 470 OHM 5% 1/4 WATT	1	3	5371-09152-00	IC2	I.C., 1408, D/A CONVERTER	1
76	4406-01117-00		6-32 HEX NUT	1	40	5010-09034-00	R25, R40	RESISTOR, C.F., 10 K OHM 5% 1/4 WATT	2	4	5281-09745-00	IC3	I.C., 74LS138, 3 TO 8 LINE DECODERS/DEMULT.	1
77	4703-00007-00		#6 EXT. LOCKWASHER	1	41	5010-10171-00	R27	RESISTOR, C.F., 56 OHM 5% 1/4 WATT	1	5	5430-08972-00	IC4, IC5, IC6	I.C., 6821, P.I.A.	3
78	20-9229		THERMAL COMPOUND	.01	42	5010-10170-00	R29	RESISTOR, C.F., 47 OHM 5% 1/4 WATT	1	6	5340-09003-00	IC7	I.C., 6810 RAM	1
79	5700-08985-00		40 PIN I.C. SOCKET	4	43	5010-10003-00	R31, R32	RESISTOR, C.F., 390 OHM 5% 1/4 WATT	2	7	5400-09250-00	IC27	I.C., 6808 MPU	1
80	5010-09534-00	W1, W3, W6, W7, W10, W11	RESISTOR, 0 OHM	6	44	5010-09160-00	R33, R35	RESISTOR, C.F., 220 OHM 5% 1/4 WATT	2	8	5400-09490-00	IC28	I.C., 6809E MICROPROCESSOR	1
					45	5010-09001-00	R43	RESISTOR, C.F., 330 OHM 5% 1/4 WATT	1	9	5281-09499-00	IC31, IC32, IC33	I.C., 74LS00 QUAD 2-INPUT NAND	3
					46	5010-09039-00	R37	RESISTOR, C.F., 10 OHM 5% 1/4 WATT	1	10	5281-09215-00	IC34, IC35	I.C., 74LS04 HEX. INVERTER	2
					47	5043-08980-00	SEE NOTE #3	CAPACITOR, CERAMIC, .01 MFD. 50V. +50-20%	38	11	5281-09487-00	IC36	I.C., 74LS74 DUAL D-TYPE FLIP-FLOP	1
					48	5041-09243-00	C36	CAPACITOR, 10 MFD. 10 V. ±10%	1	12	5281-09867-00	IC37, IC38, IC39, IC40, IC41, IC42	I.C., 74LS244, OCTAL BUFFS/LINE DRVS/LINE RECEIVERS	6
					49	5040-09776-00	C37	CAPACITOR, RADIAL, 470 MFD. 16 V. +50-10%	1	13	5310-08975-00	IC43, IC44, IC45, IC46	I.C., 4049, CMOS HEX. INVERTOR	4
					50	5043-08996-00	C38, C39	CAPACITOR, CERAMIC, .1 MFD. 50V. ±20%	2	14	5281-09500-00	IC47, IC48, IC49, IC69	I.C., 74LS32 QUAD 2-INPUT OR	4
					51	5040-09421-00	C40, C75, C76, C77, C78	CAPACITOR, ELECT. RAD. 100 MFD. 25V. +50-10%	5	15	5280-09551-00	IC50, IC51	I.C., 7425, DUAL 4-INPUT POSITION-NOR GATE WITH STROBE	2
					52	5043-09844-00	C41	CAPACITOR, AXIAL 47 PFD. 50 V. ±20%	1	16	5281-09246-00	IC52	I.C., 74LS139 DUAL 2 TO 4 LINE DECODER	1
					53	5043-09845-00	SEE NOTE #4	CAPACITOR, AXIAL .001 MFD. 50V.	33	17	5281-09247-00	IC53	I.C., 74LS02 QUAD 2-INPUT NOR	1
					54	5040-09545-00	C81	CAPACITOR, AXIAL 22 MFD. 10 V. ±20%	1	18				
					55	5160-10269-00	Q1, Q2, Q4, Q5, Q6, Q7	TRANSISTOR, 2N3904 NPN TO-92	6	19	5281-10015-00	IC56	I.C., 74LS75 4-BIT BISTABLE LATCHES	1
					56	5190-10270-00	Q3	TRANSISTOR, 2N3906 PNP TO-92	1	20	5281-09486-00	IC57	I.C., 74LS374 OCTAL D-TYPE FLIP-FLOP	1
					57	5070-09266-00	D1	DIODE, SILICON 1N5817	1	21	5671-09411-00	IC58	I.C., MAN 72A 7 SEG LED DISPLAY	1
					58	5070-06258-00	D2	DIODE, SILICON 1N4001	1	22	5340-09489-00	IC59	I.C., 5114 1K X 4 CMOS SRAM 450NS	1
					59	5075-09018-00	ZR1	ZENER DIODE, 6.8V 1N596A	1	23	5281-09743-00	IC60	I.C., 74LS08 QUAD 2-INPUT AND	1
					60	5019-09362-00	SR1, SR2, SR3, SR4	RESISTOR, 4.7 K OHM 10 PIN SIP	4	24	5281-09308-00	IC61, IC62, IC63	I.C., 74LS245 OCTAL BUS TRANSCEIVER	3
					61	5019-09786-00	SR5	RESISTOR, 4.7 K OHM 6 PIN SIP	1	25	5281-09235-00	IC64	I.C., 74LS10 TRIPLE 3-INPUT NAND GATES	1
					62					26	5281-09735-00	IC65	I.C., 74LS161 BINARY COUNTER	1
					63	5551-09822-00	L2, L4	COIL, RADIAL 4.7 UH. 3A.	2	27	5281-10014-00	IC66	I.C., 74LS20 DUAL 4-INPUT NAND	1
					64	5551-10161-00	L1, L3	COIL, RADIAL 2.0 UH. 3A.	2	28	5280-09309-00	IC67	I.C., 7407 HEX. BUF. OPEN-COLLECTOR	1
					65	5880-09022-00	B1, B2, B3	BATTERY, ALKALINE 1.5V. (AA)	3	29	5280-09010-00	IC68	I.C., 74154 4 TO 16 LINE DEC./DEMULT.	1
					66	5881-09021-00		BATTERY HOLDER #171	1	30	5010-09363-00	R1	RESISTOR, C.F., 5.6 K OHM 5% 1/4 WATT	1
					67	5641-09371-00	SW1	PUSH BUTTON SW. SPST	0	31	5010-08983-00	R2, R3, R7	RESISTOR, C.F., 3.3 K OHM 5% 1/4 WATT	3
						5641-09372-00	SW2	PUSH BUTTON SW. DPDT MOM.	2	32	5010-09179-00	R4	RESISTOR, C.F., 3.3 M OHM 5% 1/4 WATT	1
					68	5791-10027-00	H1	64 PIN R.N. HEADER (MALE)	1	33	5010-09181-00	R5	RESISTOR, C.F., 1 OHM, 10% 1/2 WATT	1
					69	5791-09028-00	H2, H3	4 PIN HEADER 09-65-1041	2	34	5010-09361-00	R6	RESISTOR, C.F., 220 OHM 5% 1/2 WATT	1
					70	5791-09444-00	H4, H5, H6	10 PIN HEADER 09-65-1101	3	35	5010-09358-00	SEE NOTE #1	RESISTOR, C.F., 1 K OHM 5% 1/4 WATT	12
					71	5791-09043-00	H7	12 PIN HEADER 09-65-1121	1	36	5010-09161-00	R9	RESISTOR, C.F., 2.2 OHM 5% 1/4 WATT	1
					72	5700-10176-00		28-PIN I.C. SOCKET	17					

NOTES:

- 1K Ω RESISTOR:**
R8, R10, R11, R12, R13, R14, R24, R30, R34, R38, R39, R41
- 270 Ω RESISTOR:**
R15, R16, R17, R18, R19, R20, R21, R22
- .01 MFD. CAPACITOR:**
C1, C2, C3, C4, C5, C6, C7, C8, C9, C10, C11, C12, C13, C14, C15, C16, C17, C18, C19, C20, C21, C22, C23, C24, C25, C26, C27, C28, C29, C30, C31, C32, C33, C34, C35, C79, C80, C82
- .001 MFD. CAPACITOR:**
C42, C43, C44, C45, C46, C47, C48, C49, C50, C51, C52, C53, C54, C55, C56, C57, C58, C59, C60, C61, C62, C63, C64, C65, C66, C67, C68, C69, C70, C71, C72, C73, C74

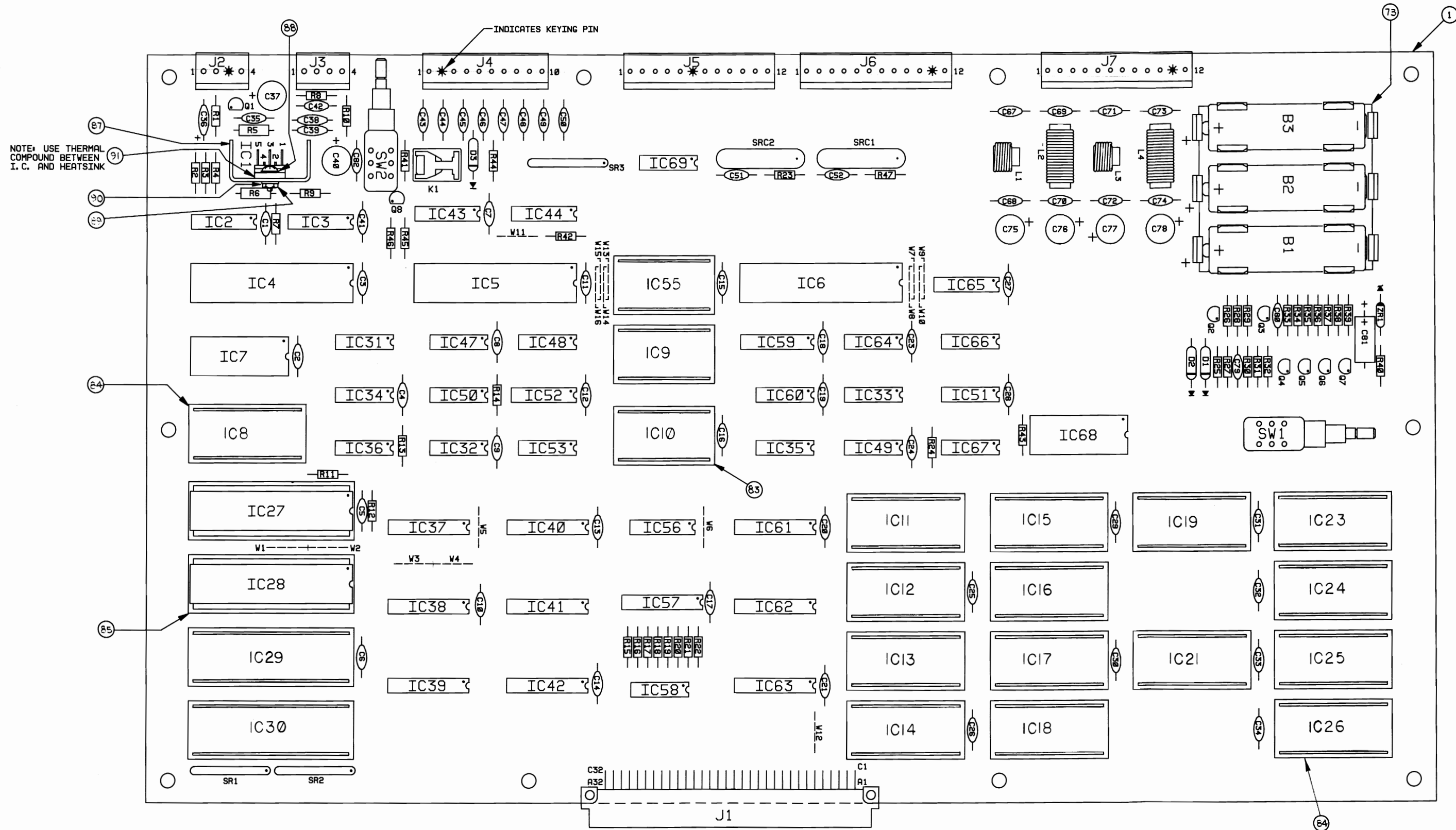

NOTE: USE THERMAL COMPOUND BETWEEN I. C. AND HEATSINK

INDICATES KEYING PIN

REV	DESCRIPTION OF CHANGE	EDN NO. DATE
A	NEW PART RELEASE REVERSED W1 & W2 JUMPERS (LOCATED AT COORD B1)	10857 6-7-83 12446 3-22-84

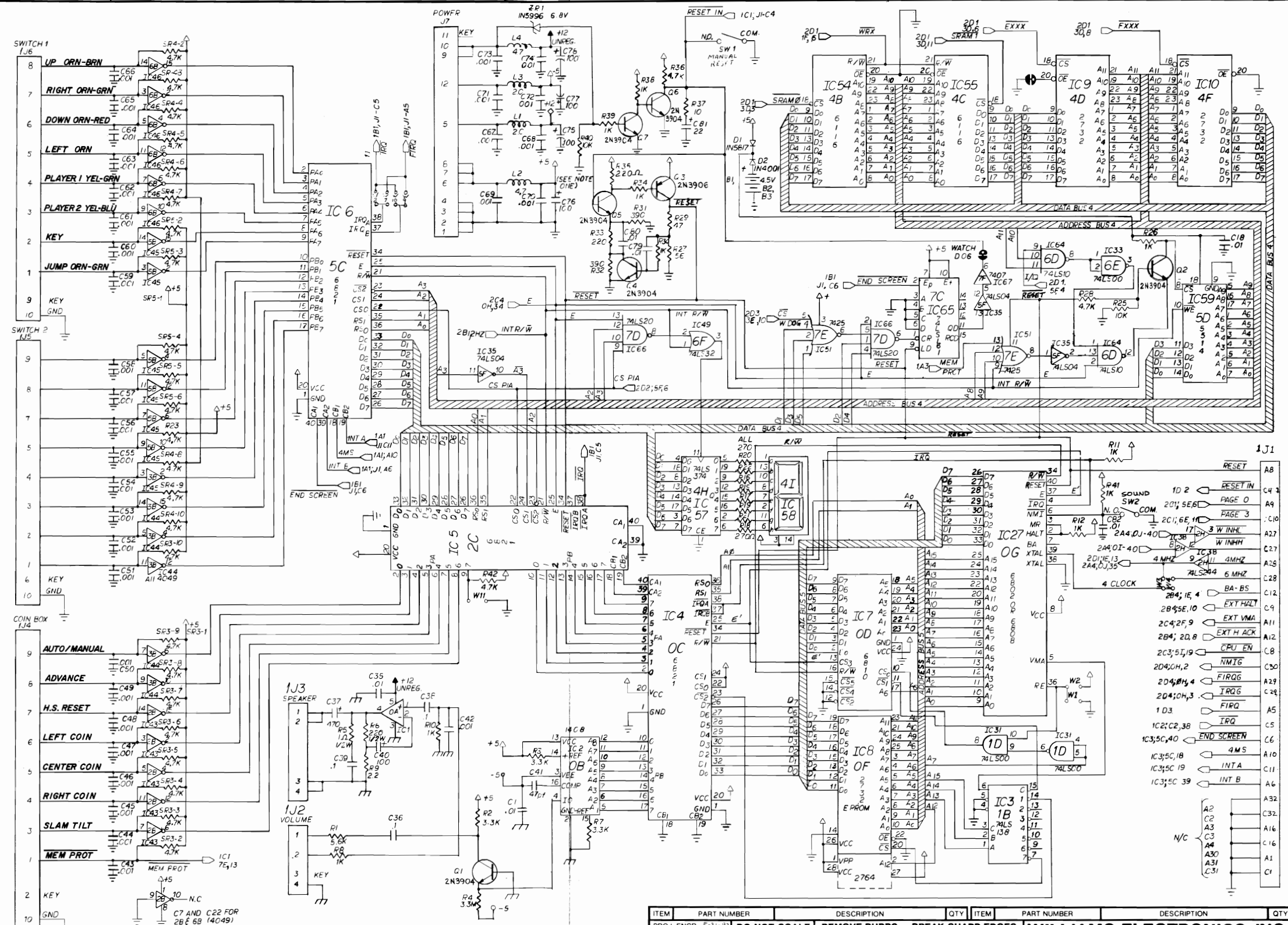

IC CHIPS NO.	VCC	GND
IC1	5	3
IC2	13	2
IC3	16	5,4
IC4, IC5	20, 24, 22	1
IC6	20	1
IC7	20	1
IC9 THRU IC26	26, 2B	14
IC27	F, 35	1, 21
IC28	7	39, 1
IC29, IC30	29	10, 16, 24
IC31 THRU 35; IC47, IC48, IC49	14	7
IC50, IC52, IC53, IC60, IC64, IC66, IC67, IC51, IC69	1	9, 8
IC36, IC37, IC38, IC43, IC44, IC45, IC46	1	9, 8
IC39, IC40, IC61, IC62, IC63, IC41, IC42, IC57	20	10
IC54, IC55, IC68	24	12
IC58	13	NONE
IC59	18	9

NOTES:
1) C2 - C34 ARE BYPASS CAPACITORS ON THE 5V LINE.

SPARE GATES		
IC'S	PIN NUMBERS	TYPES
IC31	1, 2, 3	74LS00
IC43	9, 10	4049
IC60	11, 12, 13	74LS08
IC67	1, 2, 3, 4, 10, 11, 12, 13	7407
IC69	4, 5, 6, 8, 9, 10, 11, 12, 13	74LS32

ITEM	PART NUMBER	DESCRIPTION	QTY	ITEM	PART NUMBER	DESCRIPTION	QTY
PROJ ENGR	5-31-83	DRYGALSKI		WILLIAMS ELECTRONICS, INC. 3401 N. CALIFORNIA AVE. CHICAGO IL 60618 NAME: SCHEMATIC CPU SCALE: N/S SHT. Lof 2 PART NO. 16-8843 REV A			
DOWN BY	DATE	F. GRIFFIN					
CHECKED BY	DATE	D. D.	5-31-83	FIRST PROJECT NO.	3008-K	FIRST USAGE	D-9410
APPROVAL	DATE			FIRST USAGE		QTY	1

REV	DESCRIPTION OF CHANGE	EON NO	DATE
NEW	NEW PART RELEASE	10859	8-28-83
A	SEE SHT 1 OF 2	12-46	8-22-84

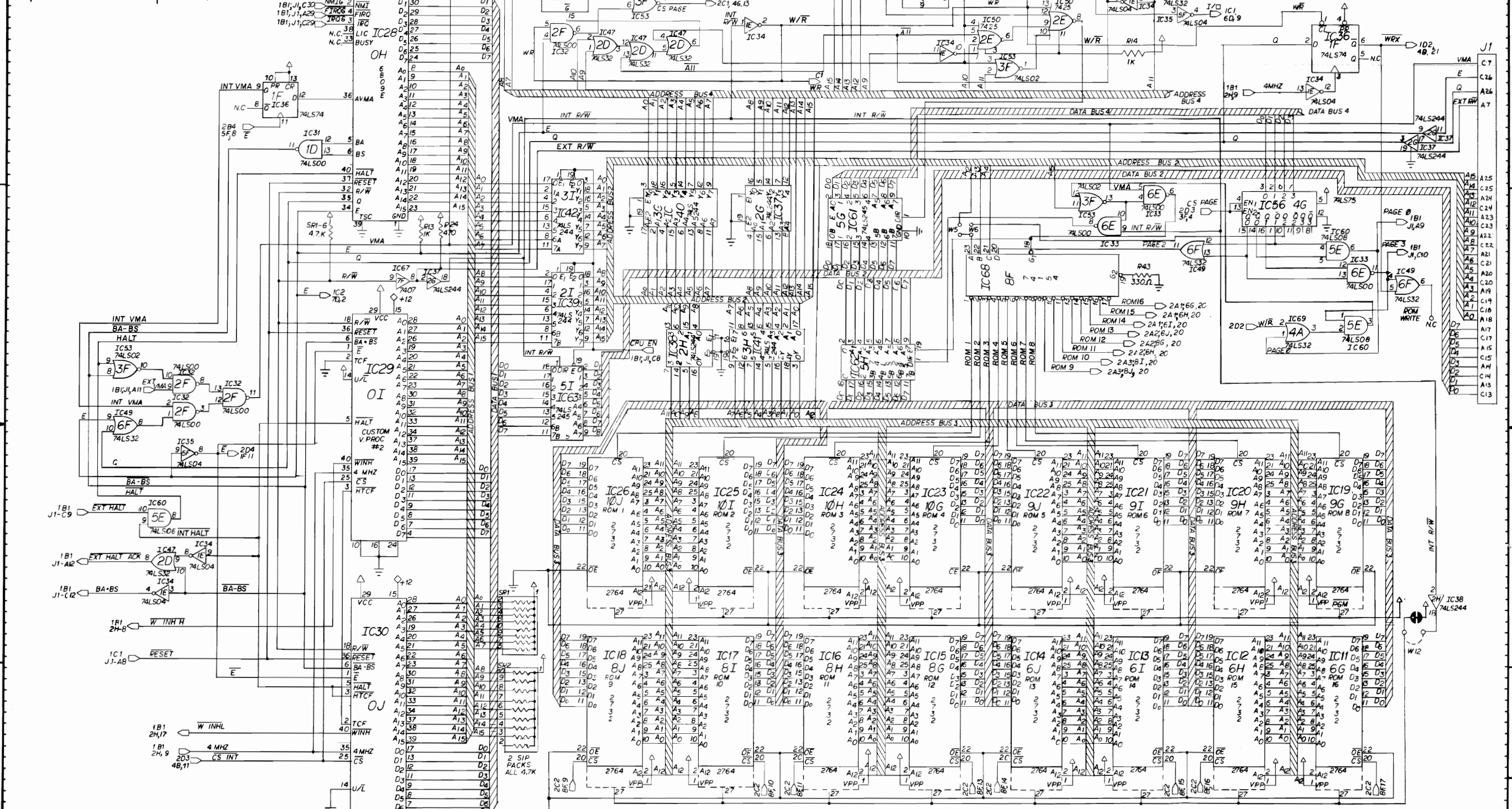

ITEM	PART NUMBER	DESCRIPTION	QTY	ITEM	PART NUMBER	DESCRIPTION	QTY
PROJ ENGR	5-31-83			WILLIAMS ELECTRONICS, INC. 3401 N. CALIFORNIA AVE. CHICAGO IL. 60618			
D. DRYGALSKI							
DOWN BY	DATE			NAME: SCHEMATIC CPU			
F. GRIFFIN	8-4-83						
CHECKED BY	DATE	FIRST PROJECT NO.		SCALE: N/S SHT: 2 OF 2 PART NO.: 16-8843 REV: A			
D. D	5-31-83	3000-K					
APPROVAL	DATE	FIRST USAGE		MATERIAL: //			
RW	6/13	D-9410					

NOTES:

1. FOR SCHEMATIC, REFER TO DWG. #16-8844
2. I.C., 74LS86: IC3, IC26, IC27, IC28, IC29, IC33, IC84.
3. I.C., 74LS74: IC6, IC12, IC25, IC50, IC52, IC53.
4. I.C., 74LS374: IC11, IC15, IC38, IC39, IC55, IC56, IC70, IC86, IC88, IC89, IC90.
5. I.C., 74LS157: IC21, IC22, IC23, IC80, IC81, IC82.
6. I.C., 74LS161: IC31, IC43, IC44, IC45, IC46.
7. I.C., 74198: IC73, IC74, IC94, IC95, IC96, IC97.
8. I.C., 4116: IC98, IC99, IC100, IC101, IC102, IC103, IC104, IC105, IC106, IC107, IC108, IC109, IC110, IC111, IC112, IC113, IC114, IC115, IC116, IC117, IC118, IC119, IC120, IC121.
9. RESISTOR, 1K OHM: R1, R2, R3, R4, R5, R32, R33, R37, R38.
- ⑩ RESISTOR, 2K OHM: R8, R12, R16, R20, R28, R29, R30, R40, R41, R42.
11. CAPACITOR, .01 MFD: C1, C2, C3, C4, C5, C6, C7, C8, C9, C10, C11, C12, C13, C14, C15, C16, C17, C18, C19, C20, C21, C22, C23, C24, C25, C26, C27, C28, C29, C30, C31, C32, C33, C34, C35, C36, C37, C38, C39, C40, C41, C42, C43, C44, C45, C46, C47, C48, C49, C50, C63, C67, C71, C73, C74, C75, C76, C77, C78, C79, C80, C81, C82, C83, C84, C85, C86, C87, C88, C89, C90, C91, C92, C93, C94, C95, C96, C97, C98, C99, C100, C101, C102, C103, C104, C105, C106, C107, C108.
12. CAPACITOR, .001 MFD: C62, C64, C66, C68, C70, C72.
13. DIODE, 1N4148: D1, D2, D3, D4, D5, D6, D7, D8, D9, D10, D11, D12, D13, D14, D15, D16, D17, D18, D19.

87					57	5160-10269-00	Q1, Q2, Q3, Q4, Q5	TRANSISTOR, 2N3904 NPN TO-92	5	28	5280-10017-00	SEE NOTE #7	I. C., 74198, 8 BIT SHIFT REGISTER	6
86					56					27	5281-09739-00	IC71, IC72, IC83	I. C., 74LS158, QUAD 2 TO 1 MULTIPLEXER	3
85					55					26	5280-09481-00	IC61, IC62, IC63, IC64	I. C., 74153, DUAL 4 TO 1 MULTIPLEXER	4
84					54	5043-09845-00	C62, C64, C66, C68, C70, C72	CAPACITOR, AXIAL, .001 MFD. 50V +/-20%	6	25	A-5282-10293	IC60	I. C., HORZ. DECODE ROM 5B	0
83					53	5040-09421-00	C61, C65, C69	CAPACITOR, RADIAL, 100 MFD. 25V +50-10%	3		A-5282-10292			I. C., HORZ. DECODE ROM 5A
82					52	5043-08996-00	C60	CAPACITOR, CERAMIC, .1 MFD. 50V +/-20%	1	24	5281-09308-00	IC54, IC85, IC87	I. C., 74LS245, 4 TO 1 BUS TRANSCEIVER	3
81					51	5043-09844-00	C54, C55, C56, C57	CAPACITOR, CERAMIC, 47 PFD. 50V +/-20%	4	23	5521-10028-00	IC48	I. C., K1116, 12 MHZ OSC 1x	1
80					50	5043-09065-00	C51, C52, C53	CAPACITOR, CERAMIC, 470 PFD. 50V +/-20%	3	22	A-5282-10294	IC47	I. C., HORZ. SYNC. ROM	1
79					49	5043-08980-00	SEE NOTE #11	CAPACITOR, CERAMIC, .01 MFD. 50V +80-20%	89	21	5340-10139-00	IC40	I. C., TC5516AP-2 CMOS S RAM 2K X 8 200 NS	0
78					48						5340-09878-00			I. C., 2016 S RAM 2K X 8 200 NS
77	A 5343-10724	IC57	ROM 19		47	5019-09669-00	SR1	RESISTOR, C. F., 1K OHM 5x 10 PIN SIP	1	20	5281-09745-00	IC37	I. C., 74LS138, 3 TO 8 DECODER	1
76	A-5343-10725	IC58	ROM 20		46					19	5281-09246-00	IC36, IC59	I. C., 74LS139, DUAL 2 TO 4 DEC.	2
75	A-5343-10726	IC41	ROM 21		45	5010-09534-00	W2, W4, W5, W6	RESISTOR, 0 OHM	4	18	5281-10014-00	IC34, IC51, IC68	I. C., 74LS20, DUAL 4-INPUT NAND	3
74					44	5010-09541-00	R36	RESISTOR, C. F., 2.7K OHM 2x 1/4 WATT	1	17	5281-09735-00	SEE NOTE #6	I. C., 74LS161, BINARY COUNTER	5
73	5700-10176-00		28 PIN I. C. SOCKET	3	43	5010-10203-00	R35	RESISTOR, C. F., 2.2K OHM 2x 1/4 WATT	1	16	5281-09235-00	IC30, IC32, IC35	I. C., 74LS10, TRIPLE 3-INPUT NAND	3
72	5700-09006-00		16 PIN I. C. SOCKET	24	42	5010-10003-00	R34, R39	RESISTOR, C. F., 390 OHM 5x 1/4 WATT	2	15	5281-09738-00	SEE NOTE #5	I. C., 74LS157, QUAD 2 TO 1 MULTIPLEXER	6
71					41	5010-10170-00	R23, R25, R29	RESISTOR, C. F., 47 OHM 5x 1/4 WATT	3	14	5281-09734-00	IC19, IC20	I. C., 74LS283, 4 BIT ADDER	2
70					40	5010-09508-00	R31	RESISTOR, C. F., 270 OHM 2x 1/4 WATT	1	13	A-5282-10295	IC14	I. C., CLOCK ROM	1
69	5791-09444-00	J3	10 PIN HEADER 09-65-1101	1	39	5010-09416-00	R22, R24, R26	RESISTOR, C. F., 470 OHM 5x 1/4 WATT	3	12	5281-09867-00	IC13, IC24	I. C., 74LS244, OCTAL BUF	2
68	5791-09497-00	J2	7 PIN HEADER 09-65-1071	1	38	5010-10204-00	R9, R13, R17, R21	RESISTOR, C. F., 1K OHM 2x 1/4 WATT	4	11	5281-09486-00	SEE NOTE #4	I. C., 74LS374, OCTAL D F/F	11
67	5792-10026-00	J1	64 PIN R. N. HEADER FEMALE	1	37	5010-10205-00	SEE NOTE #10	RESISTOR, C. F., 2K OHM 2x 1/4 WATT	10	10	5281-09856-00	IC10, IC91, IC92, IC93	I. C., 74LS373, OCTAL D LATCH	4
66					36	5010-10000-00	R7, R11, R15, R19	RESISTOR, C. F., 3.9K OHM 5x 1/4 WATT	4	9	5281-09247-00	IC9, IC16	I. C., 74LS02, QUAD 2-INPUT NOR	2
65					35	5010-09219-00	R6, R10, R14, R18	RESISTOR, C. F., 8.2K OHM 5x 1/4 WATT	4	8	5281-09499-00	IC8, IC65	I. C., 74LS00, QUAD 2-INPUT NAND	2
64	5551-09822-00	L4	COIL, RADIAL, 4.7 UH 3 A.	1	34	5010-09358-00	SEE NOTE #9	RESISTOR, C. F., 1K OHM 5x 1/4 WATT	9	7	5281-09487-00	SEE NOTE #3	I. C., 74LS74, DUAL D F/F	6
63	5551-10161-00	L2, L3	COIL, RADIAL, 2.0 UH 3 A.	2	33					6	5280-09551-00	IC5	I. C., 7425, DUAL 4-INPUT W/STROBE NOR	1
62	5551-09825-00	L1	COIL, RADIAL, 4.7 UH 30 MA	1	32					5	5281-09743-00	IC4, IC7, IC49	I. C., 74LS08, QUAD 2-INPUT AND	3
61					31	5340-09488-00	SEE NOTE #8	I. C., 4116 RAM/D 16K X 1, 450 NS	24	4	5281-09737-00	SEE NOTE #2	I. C., 74LS86, QUAD 2-INPUT EXOR	7
60					30	5281-09853-00	IC79	I. C., 74LS85 4 BIT COMPARATOR	1	3	5281-09500-00	IC2, IC7, IC42, IC66, IC67	I. C., 74LS32, QUAD 2-INPUT OR	5
59	5070-08919-00	SEE NOTE #13	DIODE, 1N4148 150 MA	19	29	5340-10019-00	IC75, IC76, IC77, IC78	I. C., 2149 RAM/S 1K X 4, 70 NS	0	2	5281-09215-00	IC1, IC18, IC69	I. C., 74LS04, HEX. INVERTER	3
58						5340-10018-00		I. C., 2148 RAM/S 1K X 4, 70 NS	4	1	5777-09960-00		BARE P. C. BOARD (REV. - A)	1
ITEM	PART NO.	PART DESIGNATION	DESCRIPTION	QTY.	ITEM	PART NO.	PART DESIGNATION	DESCRIPTION	QTY.	ITEM	PART NO.	PART DESIGNATION	DESCRIPTION	QTY.

BILL OF MATERIALS

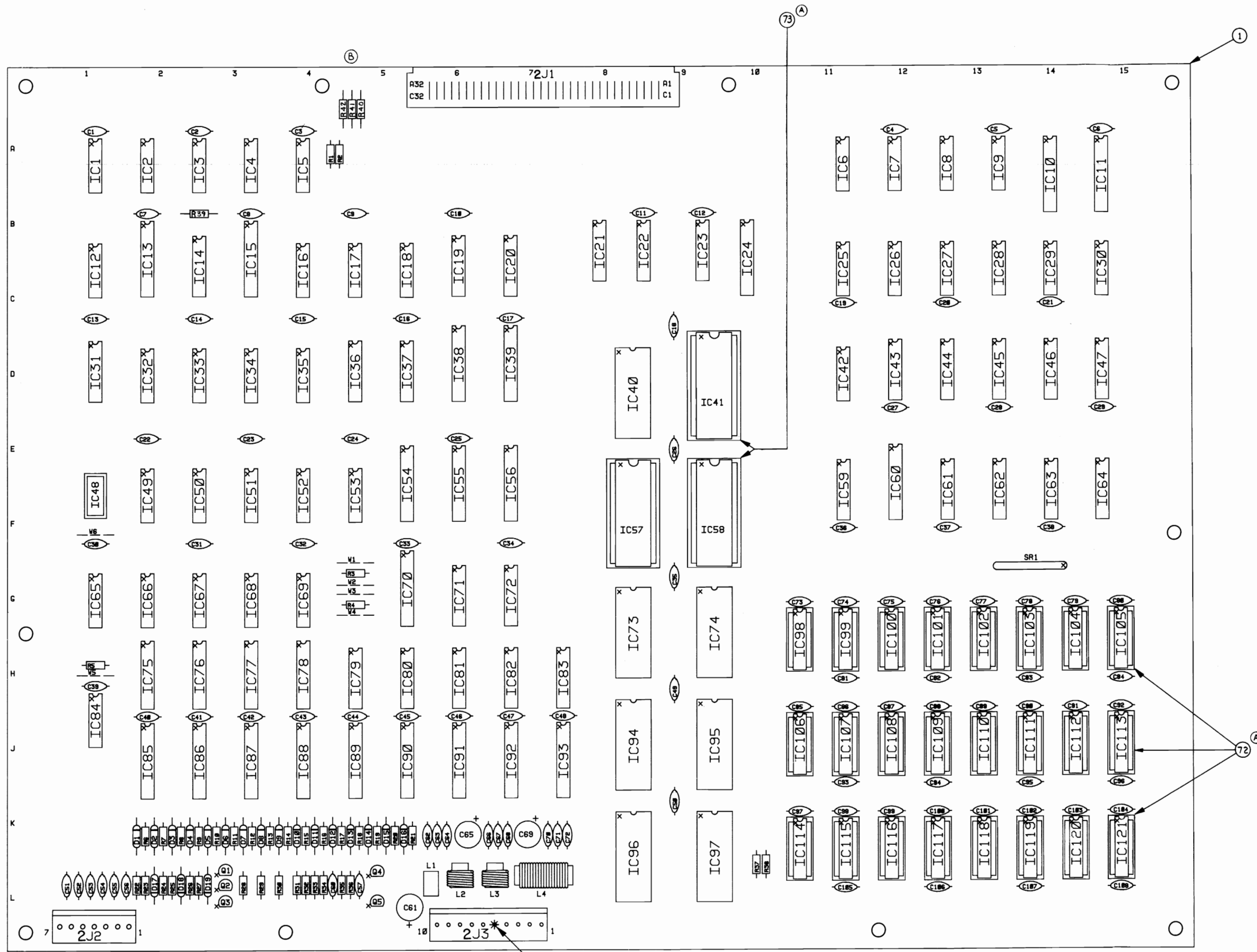

INDICATES KEYING PIN

REV	DESCRIPTION OF CHANGE	ECN NO.	DATE
NPR		10854	6-7-83
A	SEE SHEET 2 FOR DETAILS	11093	6-30-83
B	ADDED 3 RESISTOR LOCATIONS: R40, R41, R42	12286	7-2-83

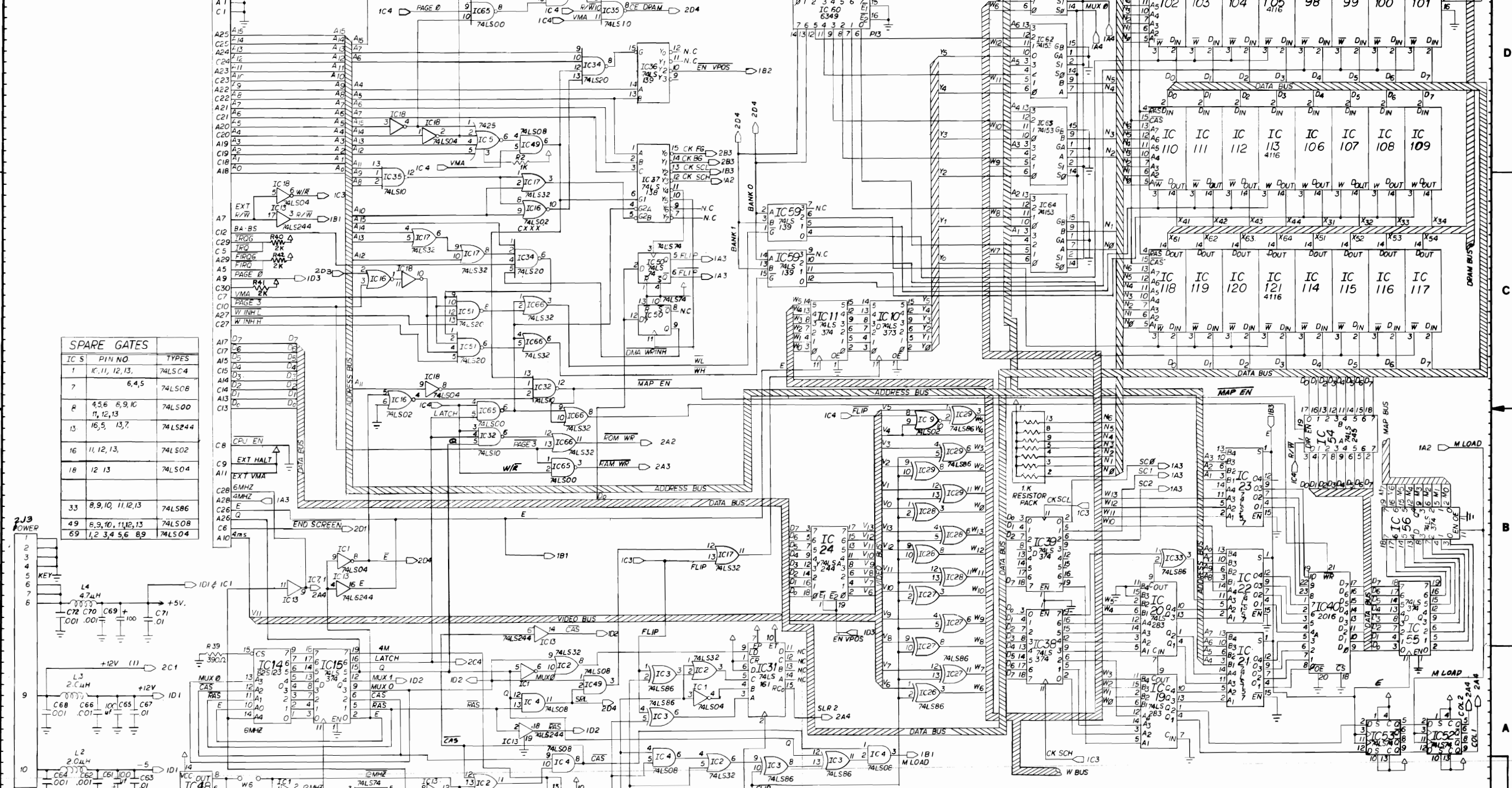

IC #	PIN NO.	TYPES
1	10, 11, 12, 13	74LS04
7	6, 4, 5	74LS08
8	4, 5, 6, 9, 10, 11, 12, 13	74LS00
13	16, 5, 13, 7	74LS244
16	11, 12, 13	74LS02
18	12, 13	74LS04
33	8, 9, 10, 11, 12, 13	74LS86
49	8, 9, 10, 11, 12, 13	74LS08
69	1, 2, 3, 4, 5, 6, 8, 9	74LS04

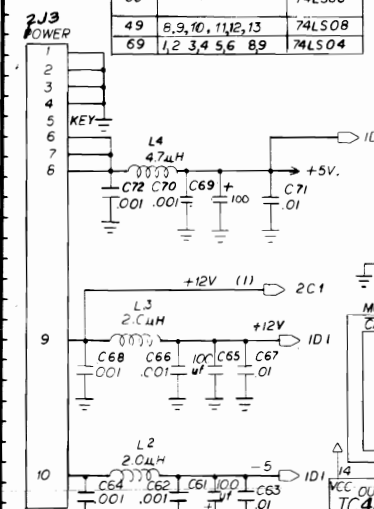

ITEM	PART NUMBER	DESCRIPTION	QTY	ITEM	PART NUMBER	DESCRIPTION	QTY
PROJ. ENGR	Don DRYGALSKI	DO NOT SCALE WORK TO DIMENSIONS SHOWN		REMOVE BURRS - BREAK SHARP EDGES TOLERANCES UNLESS OTHERWISE SPECIFIED			
CHKD BY	F. GRIFFIN	FIRST PROJECT NO. 3008		FRACTIONAL ±.1/64 ANGULAR .1° DECIMAL ±.005 FILLETS .020 MAX MATERIAL			
APPROVAL	DATE 7-11-82	FIRST USAGE		WILLIAMS ELECTRONICS, INC. 3401 N. CALIFORNIA AVE. CHICAGO IL 60618			
SCHEMATIC VIDEO				SCALE 1/16" = 1" SHT 1 OF 2 PART NO. 16-8844 REV B			

REV	DESCRIPTION OF CHANGE	ECN NO.
	NPR	10856 6-7-83
A	IC 79 CHANGED FROM 74LS157 TO 74LS 85. ALSO LINE SHORTING OUT R28 WAS REMOVED	11093 6-30-83
B	SEE SHT 1 OF 2	11228 8-13-83

VCC GND TABLE		
IC TYPE	VCC	GND
1 THRU 9 - 12, 16, 17, 18, 25 THRU 30, 32 THRU 37, 42, 47 THRU 54, 59, 65 THRU 69	14	7
10, 11, 13, 15, 24, 38, 39, 54, 55, 56, 60, 70, 85 THRU 94 - 96, 97	20	10
14, 19 THRU 23, 31, 43 THRU 46 - 61, 62, 63, 64, 71, 72, 79, THRU 83	16	8
40, 73, 74, 95	24	12
41, 57, 58	26, 28	14
75 THRU 78	18	9
98, THRU 121	9	16

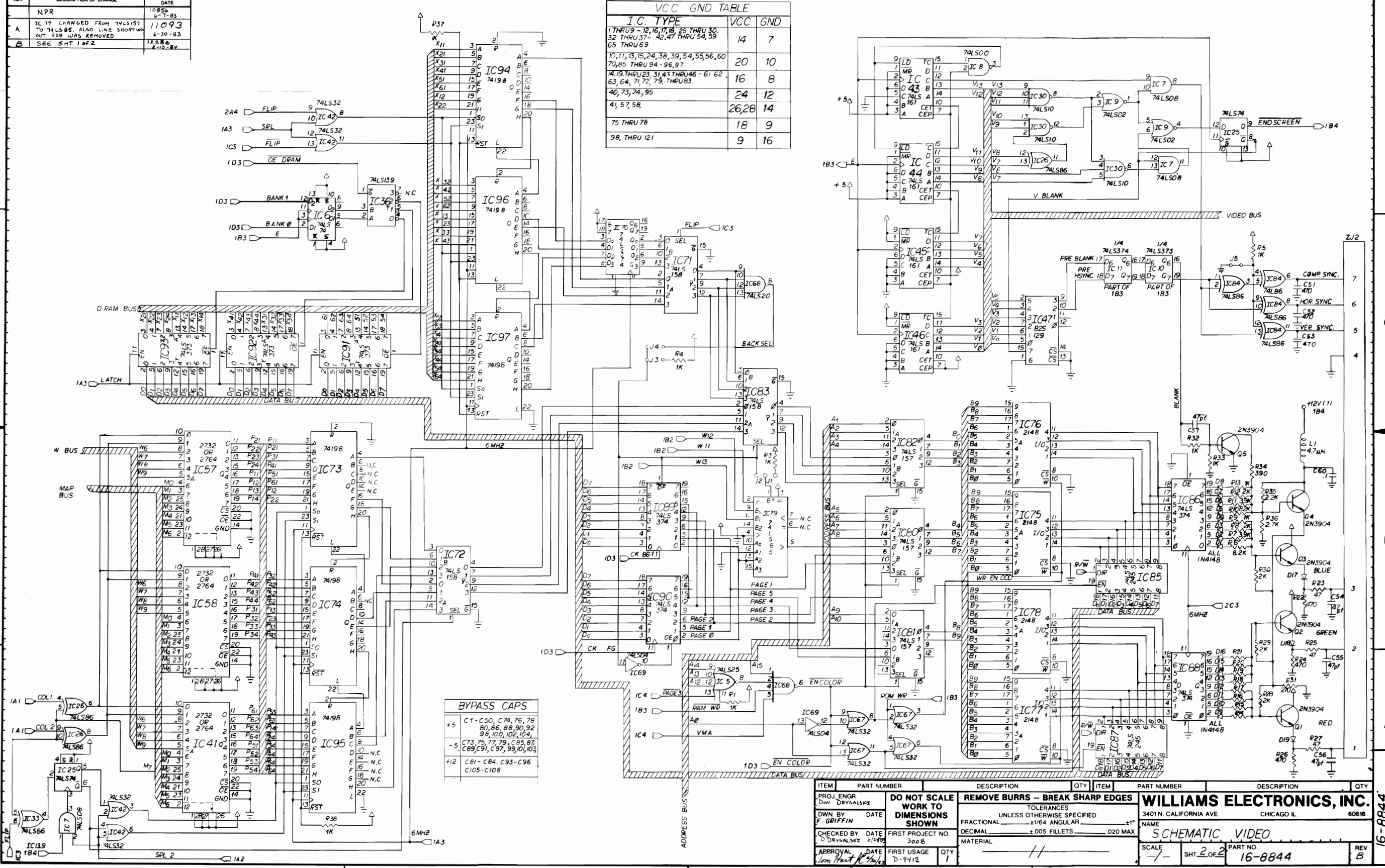

BYPASS CAPS	
+5	C1 - C50, C74, 76, 78, 80, 86, 88, 90, 92, 98, 100, 102, 104
-5	C73, 75, 77, 79, C85, 87, C89, C91, C97, 99, 101, 103
+12	C81 - C84, C93 - C96, C105 - C108

ITEM	PART NUMBER	DESCRIPTION	QTY	ITEM	PART NUMBER	DESCRIPTION	QTY
PROJ ENGR	Don Dryalske			WILLIAMS ELECTRONICS, INC. 3401 N. CALIFORNIA AVE. CHICAGO IL. 60618 NAME: SCHEMATIC VIDEO SCALE: 1/1 SHT: 2 OF 2 PART NO: 16-8844 REV: B			
OWN BY	F. GRIFFIN						
CHECKED BY	DATE	FIRST PROJECT NO.	3008				
APPROVAL	DATE	FIRST USAGE	D-9412				

BILL OF MATERIAL

ITEM NO.	PART NO.	PART DESIGNATION	DESCRIPTION	REQ'D NO.
1	5773-09679-00		BARE P.C. BOARD	1
2	5010-09085-00	R23	RESISTOR, 1.5K 5%, 1/4W	1
3	5010-09541-00	R13, R15	RESISTOR, 2.7K 2%, 1/4W	2
4	5010-09508-00	R21	RESISTOR, 270Ω 2%, 1/4W	1
5	5010-09428-00	R20	RESISTOR, 1.5K 2%, 1/4W	1
6	5010-09509-00	R16	RESISTOR, 1.1K 2%, 1/4W	1
7	5010-09510-00	R7	RESISTOR, 12K 2%, 1/4W	1
8	5010-09314-00	R4	RESISTOR, 1.2K 5%, 1/4W	1
9	5010-09416-00	R1, R14	RESISTOR, 470Ω 5%, 1/4W	2
10	5013-09342-00	R11	RESISTOR, 7.32K 1%, 1/4W	1
11	5013-09427-00	R12	RESISTOR, 9.99K 1%, 1/4W	1
12	5013-09426-00	R25	RESISTOR, 2.15K 1%, 1/4W	1
13	5012-09423-00	R3	RESISTOR, 12Ω 5%, 5W	1
14	5012-09512-00	R2	RESISTOR, 27Ω 5%, 5W	1
15	5012-09497-00	R27	RESISTOR, 0.4Ω 5%, 3W	1
16	5013-09665-00	R26	RESISTOR, 5.11K 1%, 1/4W	1
17	5010-09434-00	R6, R18	RESISTOR, C.F. 22Ω ± 5%, 1/4W	2
18	5010-09036-00	R5, R9, R17, R22	RESISTOR, C.F. 100Ω ± 5%, 1/4W	4
19	5010-09033-00	R8, R19	RESISTOR, C.F. 10Ω ± 5%, 1/4W	2
20	5010-09534-00	W1	RESISTOR, 0Ω	1
21	5043-08986-00	C6, C7	CAPACITOR, 0.1μF CERAMIC ±80% -20% 50V	2
22	5040-09421-00	C2, C16	CAPACITOR, 100MFD, 25V RADIAL +50% -10%	2
23	5040-09422-00	C15	CAPACITOR, 47MFD, 50V RADIAL +50% -10%	1
24	5040-09420-00	C3	CAPACITOR, 1000MFD, 25V RADIAL +75% -10%	1
25	5040-09419-00	C10	CAPACITOR, 18,000MFD 20V AXIAL +75% -10%	1
26	5040-09423-00	C5	CAPACITOR, 330MFD 10V RADIAL +50% -10%	1
27	5040-09504-00	C14	CAPACITOR 4700MFD 35V RADIAL +50% -10%	1
28	5043-09446-00	C1, C4 & C12	CAPACITOR .1MFD, 50V AXIAL 25V -20 +60%	3
29	5043-08065-00	C9	CAPACITOR 470PFD 50V AXIAL XTR ± 10%	1
30	5043-09492-00	C8	CAPACITOR 100PFD 50V AXIAL 52L ± 5%	1
31	5040-09506-00	C13	CAPACITOR 220MFD 16V RADIAL +50% -10%	1
32	5040-09493-00	C11	CAPACITOR 22MFD 10V RADIAL +50% -10%	1
33	5070-06258-00	D1, D2 & D3	DIODE, 1N4001	3
34	5075-09406-00	ZR1	ZENER, 1N5234 ± 5% (6.2V)	1
35	5075-09662-00	ZR2	ZENER 1N5249 ± 5% (14V)	1
36	5130-09430-00	Q3, Q4	TRANSISTOR, MPS 455	2
37	5130-09661-00	Q1, Q2	SCR 8 AMP, 100V	2
38	5250-09515-00	Q5	VOLTAGE REGULATOR, 7905	1
39	5460-09424-00	IC1, IC2	VOLTAGE REGULATOR, 723	2
40	5100-09699-00	BR1	BRIDGE RECTIFIER, 35 AMP, 200V	1
41	5100-09513-00	BR2	BRIDGE RECTIFIER, 4.0A, 50V	1
42	5100-09514-00	BR3	BRIDGE RECTIFIER, 1.0A, 50V	1
43	5671-09018-00	LED1, LED2, LED3	LED, RED	3
44	5824-09298-00	TP1 - TP6	TERMINAL # 1502-1 (TEST POINT)	4

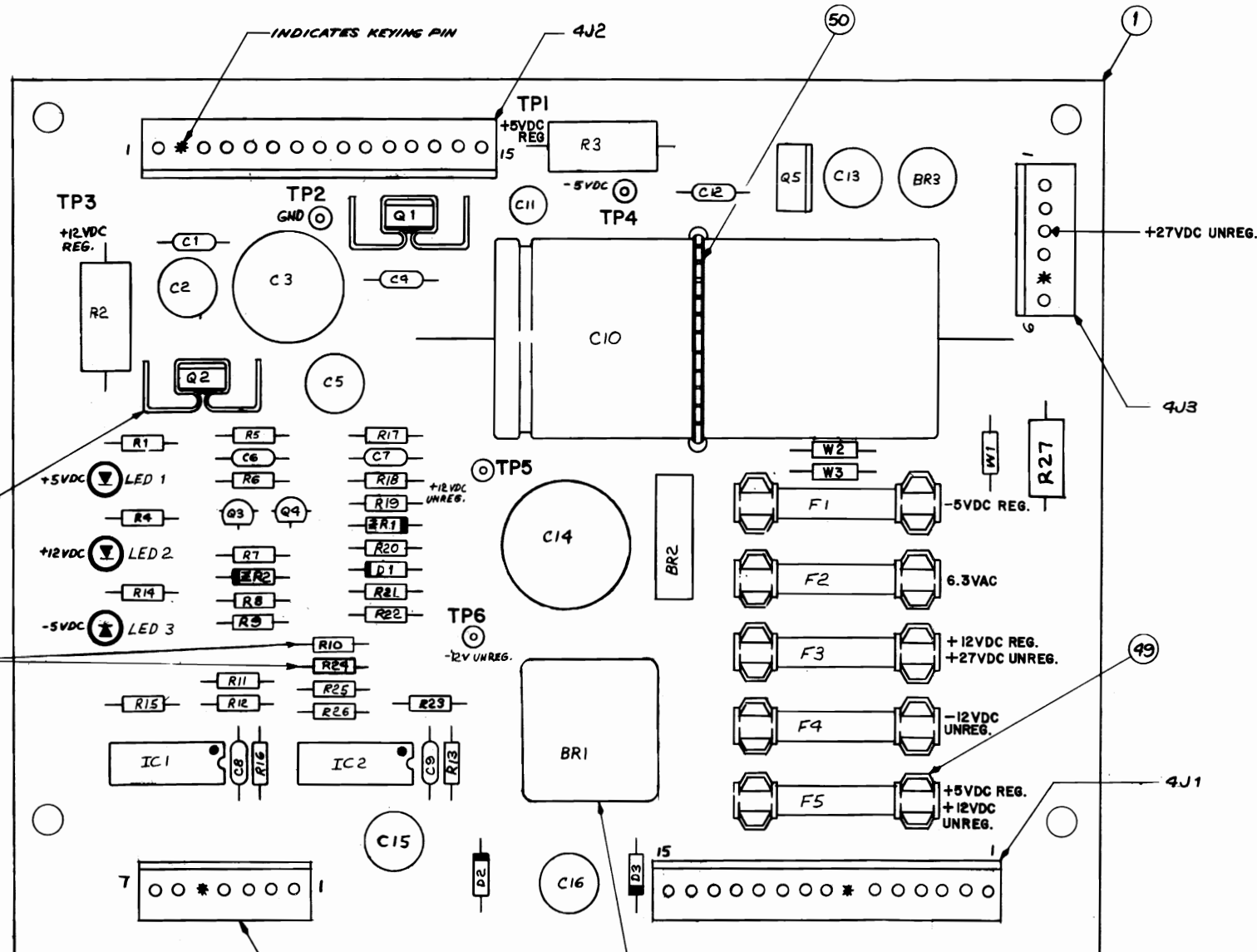

NOTES:
 1. REMOVE R24 IF +5VDC IS GREATER THAN 5.25 VDC, REMOVE R10 IF +5VDC IS LESS THAN 4.75 VDC.
 2. BR1 MUST BE MOUNTED 1/8" ABOVE SURFACE OF BOARD.
 3. FOR SCHEMATIC REFER TO 16-8811.

45	5731-09432-00	F4 & F5	FUSE, TA, S.B.	2
46	5731-06314-00	F3	FUSE, 9A, S.B., 250V	1
47	5731-06569-00	F1	FUSE, 1A, S.B., 250V	1
48	5731-09651-00	F2	FUSE, 5A, S.B., 250V	1
49	5732-09178-00		FUSEHOLDER,	10
50	03-7520		TIE WRAP	1
51	5791-09074-00	4J1 & 4J2	HEADER, 15 PIN 09-65-1051	2
52	5791-09038-00	4J3	HEADER, 6 PIN 09-65-1061	1
53	5791-09497-00	4J4	HEADER, 1 PIN 09-65-1071	1
54	5705-09663-00		HEAT SINK	2
	5705-09669-00		HEAT SINK	0
55	5010-09682-00	R10	RESISTOR C.F. 51K ± 5% 1/4W	1
56	5010-09324-00	R24	RESISTOR, C.F. 27K ± 5% 1/4W	1

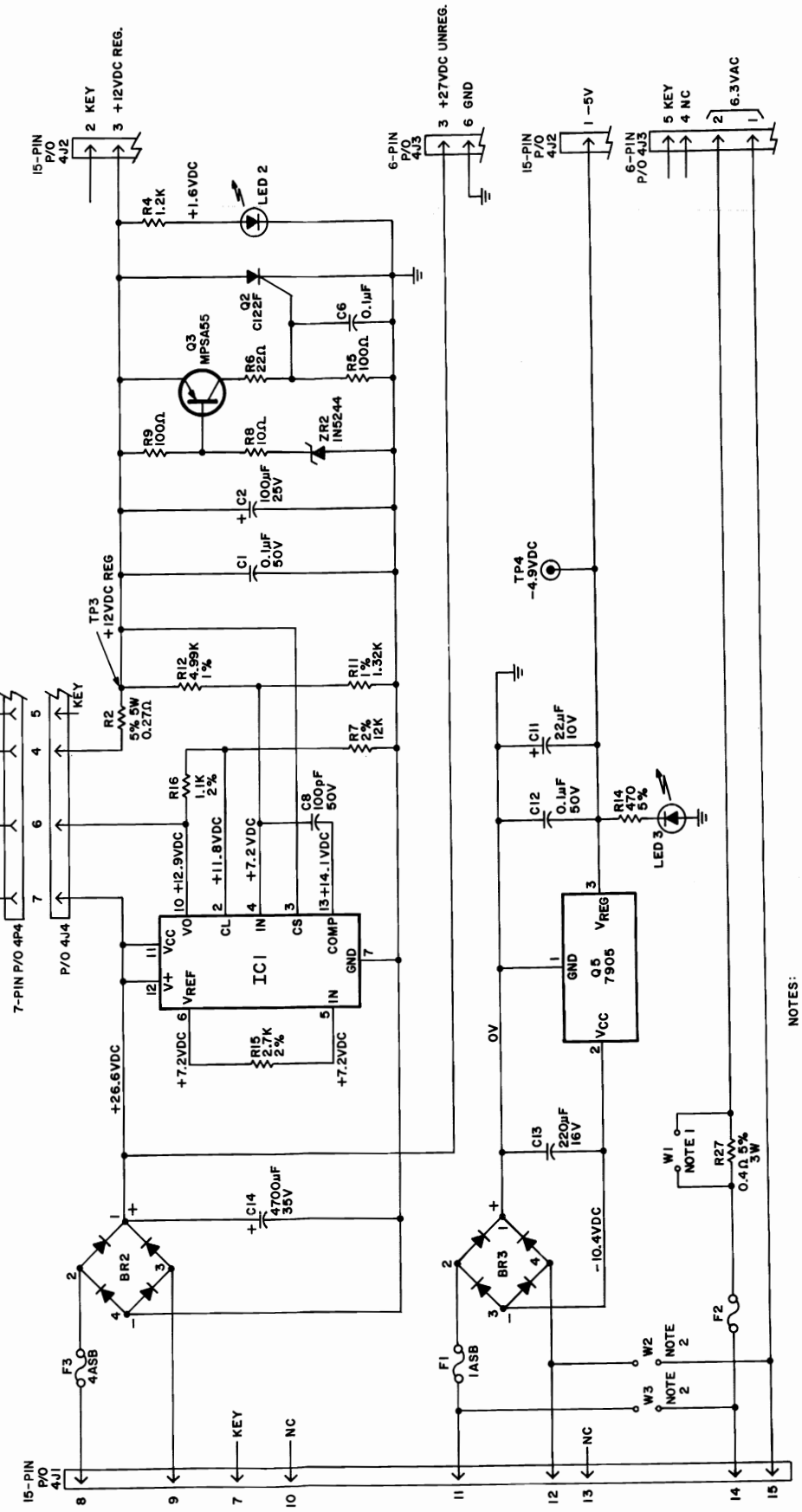
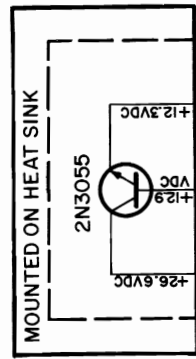
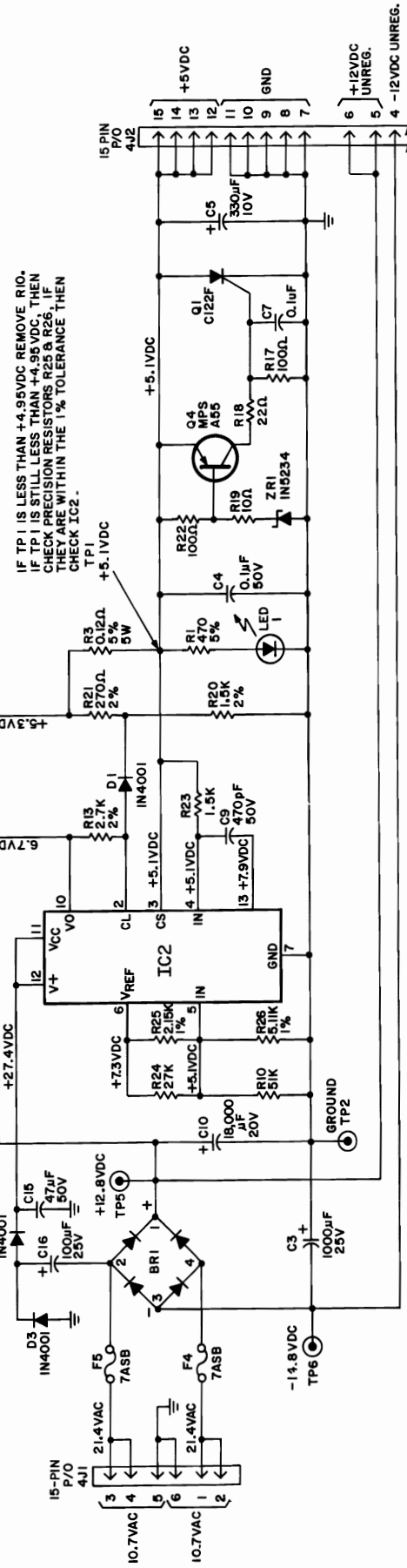
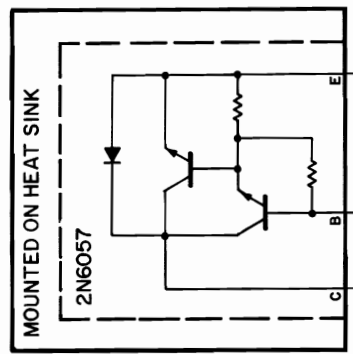
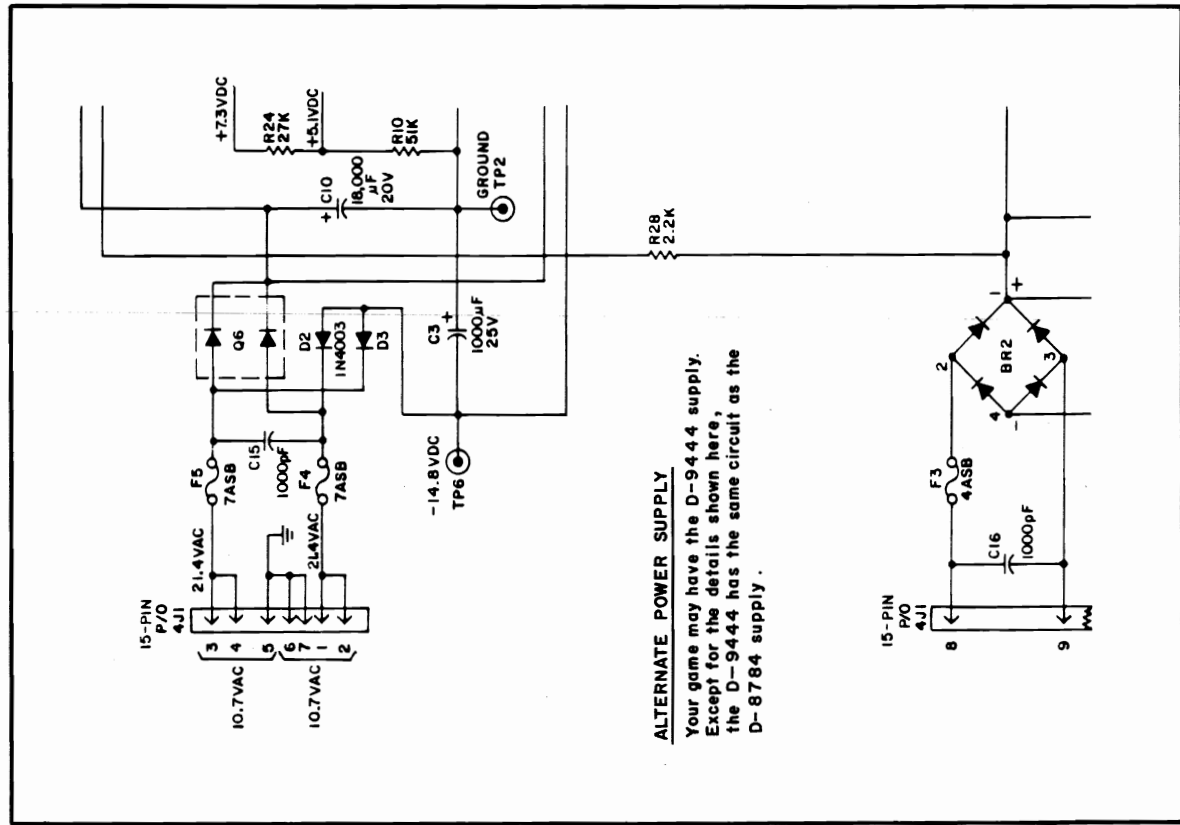

3A LOCATION APPROXIMATE

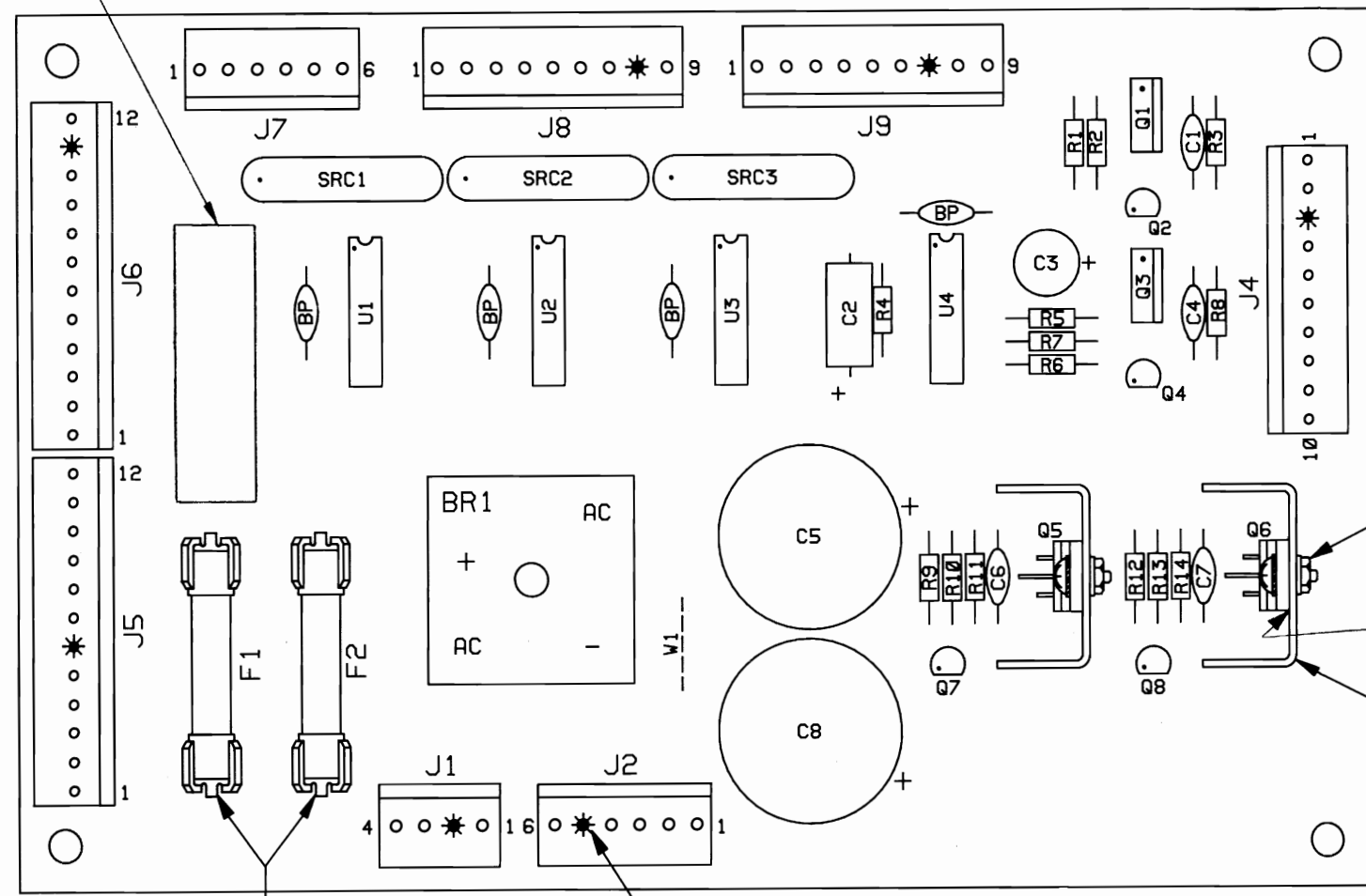

21

INDICATES KEYING PIN

1

32
30 31

33 SEE NOTE 3

29

NOTES:

1. FOR SCHEMATIC, REFER TO DRAWING NO. 16-8910.
2. RESISTOR, 4.7K, R1, R2, R6, R7, R10, R13.
3. APPLY ITEM 33 BETWEEN ITEMS 7 & 29.

34	16-8850-113		LABEL - PCB ASSY ID	1
33	20-9229		THERMAL COMPOUND	.010
32	4703-00007-00		#6 EXT. TOOTH LOCKWASHER	2
31	4406-01117-00		6-32 HEX NUT	2
30	4006-01003-06		6-32 x 3/8 P-H.S. SCREW	2
29	5705-09199-00		HEATSINK	2
28	5010-09548-00	R11, R14	RESISTOR, C.F., 68 OHM 2% 1/4 WATT	2
27	5791-09028-00	J1	4-PIN HEADER, 09-65-1041	1
26	5791-09038-00	J2, J7	6-PIN HEADER, 09-65-1061	2
25	5791-09027-00	J8, J9	9-PIN HEADER, 09-65-1091	2
24	5791-09444-00	J4	10-PIN HEADER, 09-65-1101	1
23	5791-09043-00	J5, J6	12-PIN HEADER, 09-65-1121	2
22	5731-09651-00	F1, F2	FUSE, S.B. 5 A. 250V	2
21	5732-09178-00		FUSEHOLDER	4
20	5043-08980-00	BP	CAPACITOR, AXL. .01 MFD. 50V +80-20%	4
19	5043-08996-00	C1, C4, C6, C7	CAPACITOR, AXL. .1 MFD. 50V +/-20%	4
18	5041-09243-00	C2	CAP., ELECT. AXL. 10 MFD. 10V +/-10%	1
17	5040-09776-00	C3	CAP., ELECT. RAD. 470 MFD. 16V +/-20%	1
16	5040-09504-00	C5, C8	CAP., ELECT. RAD. 4700 MFD. 35V +50-10%	2
15	5010-09534-00	W1	RESISTOR, C.F., 0 OHM	1
14	5010-09113-00	R5	RESISTOR, C.F., 35K OHM 5% 1/4 WATT	1
13	5010-08774-00	R4	RESISTOR, C.F., 22K OHM 5% 1/4 WATT	1
12	5010-09224-00	R3, R8	RESISTOR, C.F., 270 OHM 5% 1/4 WATT	2
11	5010-09358-00	R9, R12	RESISTOR, C.F., 1K OHM 5% 1/4 WATT	2
10	5010-08991-00	SEE NOTE #2	RESISTOR, C.F., 4.7K OHM 5% 1/4 WATT	6
9	5161-08979-00	Q1, Q3	TRANSISTOR, 2N6122 NPN	2
8	5190-10270-00	Q2, Q4, Q7, Q8	TRANSISTOR, 2N3906 PNP	4
7	5162-09410-00	Q5, Q6	TRANSISTOR, TIP122 NPN	2
6	5100-09690-00	BR1	BRIDGE RECTIFIER, 35 A. 200V	1
5	5060-10396-00	SRC1, SRC2, SRC3	SIP, 4.7K, 470 PFD., 8R, 8C	3
4	5310-08975-00	U1	I.C., 4049 CMOS HEX. INVERTER	1
3	5281-10007-00	U4	I.C., 74LS123 DUAL MLT/VIB	1
2	5281-09738-00	U2, U3	I.C., 74LS157 QUAD 2 TO 1 MLTPX	2
1	5772-10697-00		BARE P.C. BOARD	1
ITEM	PART NO.	PART DESIGNATION	DESCRIPTION	QTY.

BILL OF MATERIALS

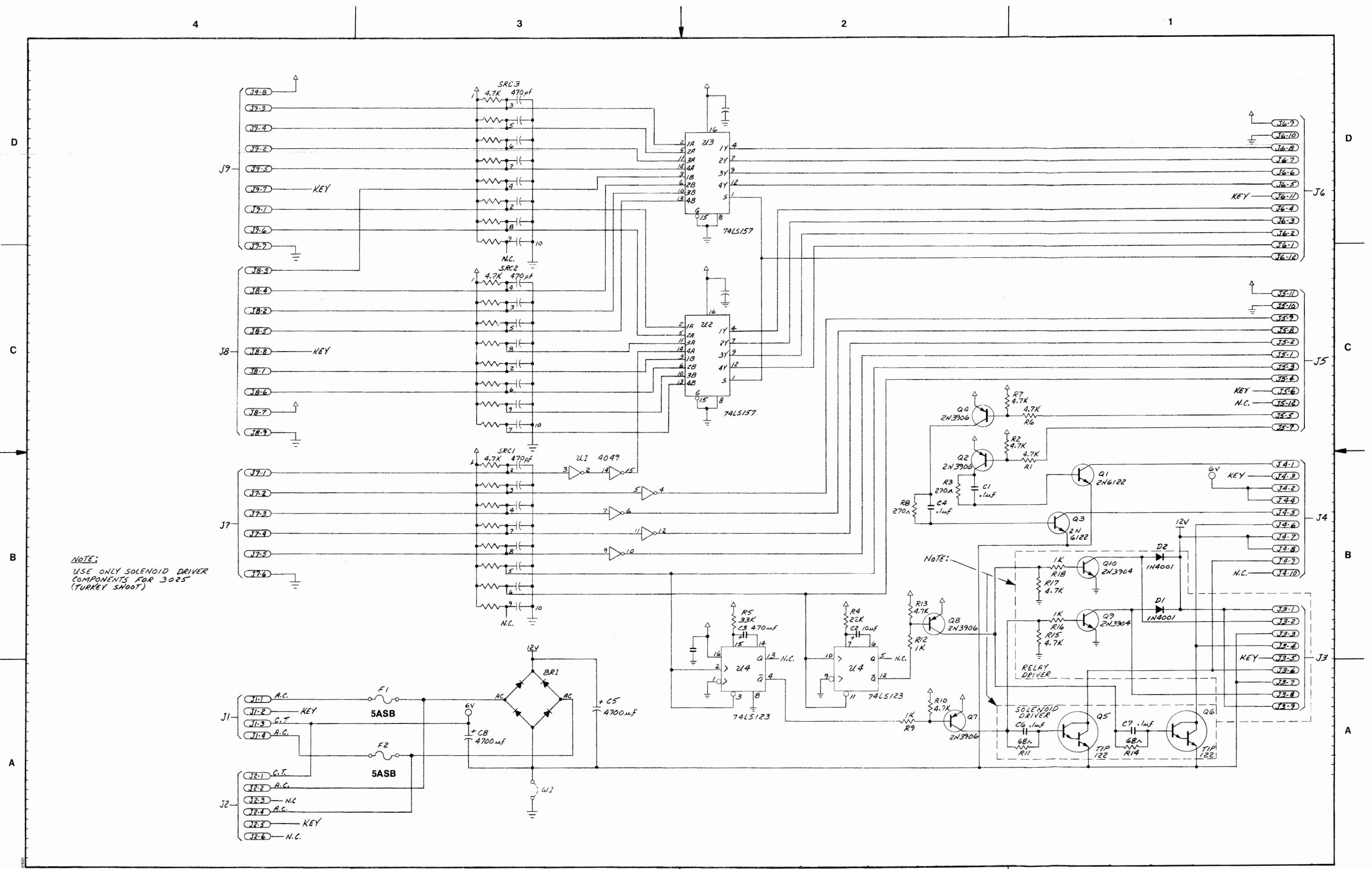

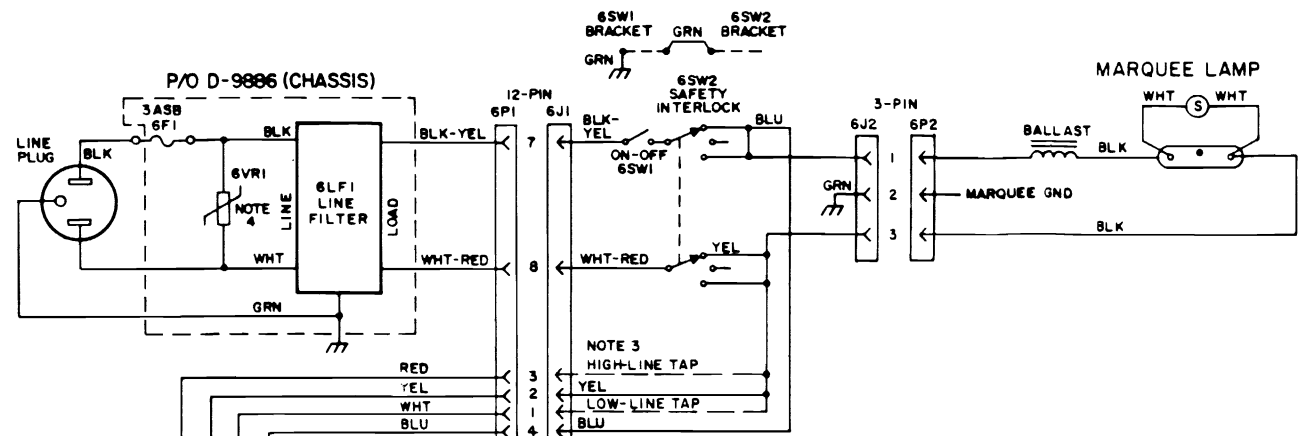

CAUTION

GREEN LEADS TERMINATE AT D-9886 POWER PACK ASSEMBLY CHASSIS AND PROVIDE SAFETY GROUND TO THE MARQUEE, MONITOR, SWITCH BRACKETS AND PCB PLATE MOUNTING BRACKET. IF A GREEN LEAD MUST BE DISCONNECTED DURING MAINTENANCE, BE SURE TO RECONNECT IT.

NOTE: Power-supply outputs are shown on the facing page.

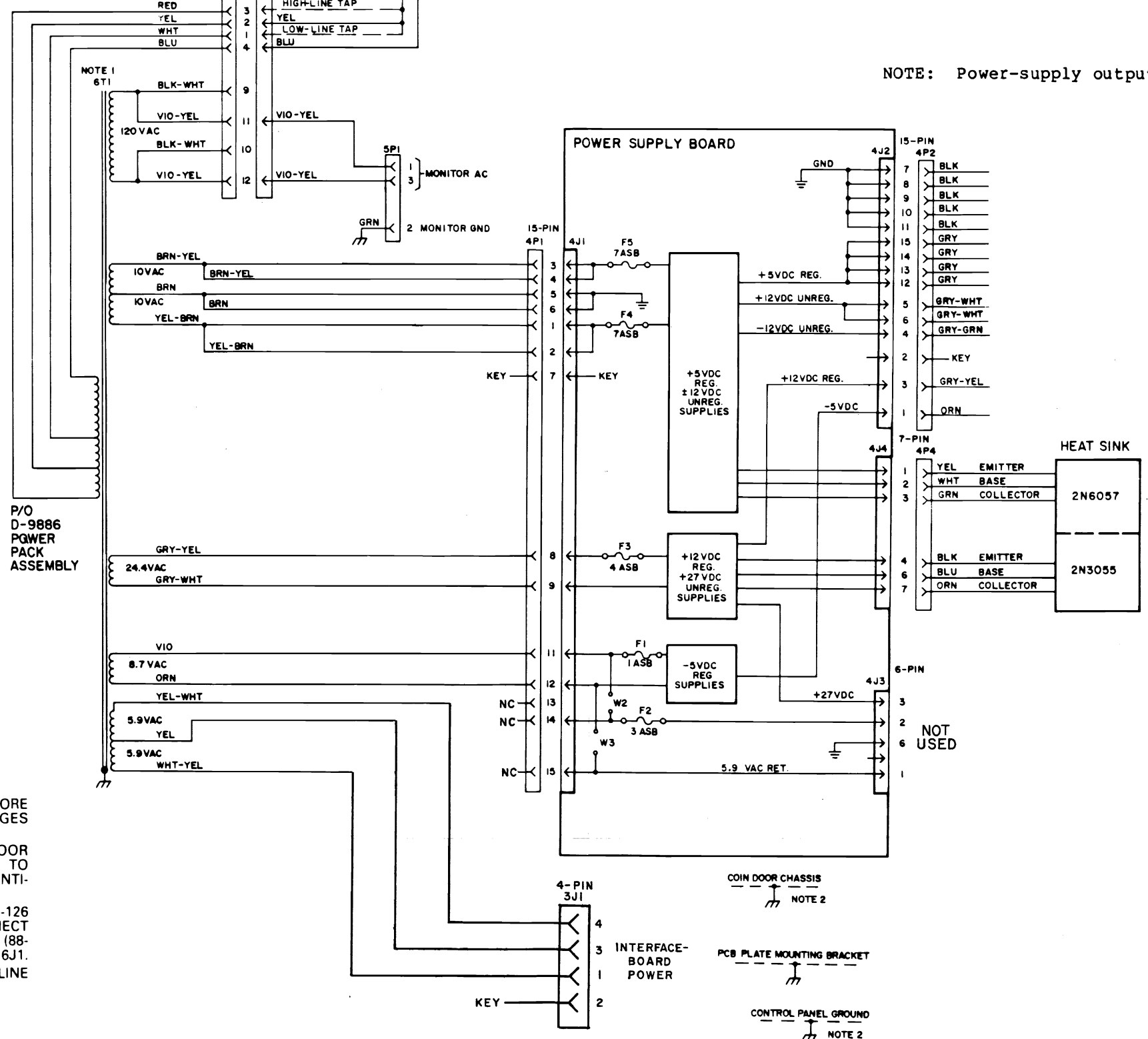

- NOTES:**
1. 6T1 TRANSFORMER, PART NO. A-5610-10252. CORE IS GROUNDED TO D-9886 CHASSIS. VOLTAGES SHOWN ARE MINIMUM FOR 117 VAC INPUT.
 2. GROUND BRAID WIRE CONNECTS COIN DOOR GROUND AND CONTROL PANEL GROUND TO EARTH GROUND (ON D-9886 CHASSIS) FOR ANTI-STATIC PROTECTION.
 3. CONNECTION SHOWN ASSUMES NORMAL (98-126 VAC) INPUT. FOR HIGH LINE (113-145 VAC) CONNECT YELLOW WIRE TO PIN 3 OF 6J1. FOR LOW LINE (88-113 VAC) CONNECT YELLOW WIRE TO PIN 1 OF 6J1.
 4. 130V VARISTOR PART NO. 5017-09063 AND LINE FILTER PART NO. 5102-08895.

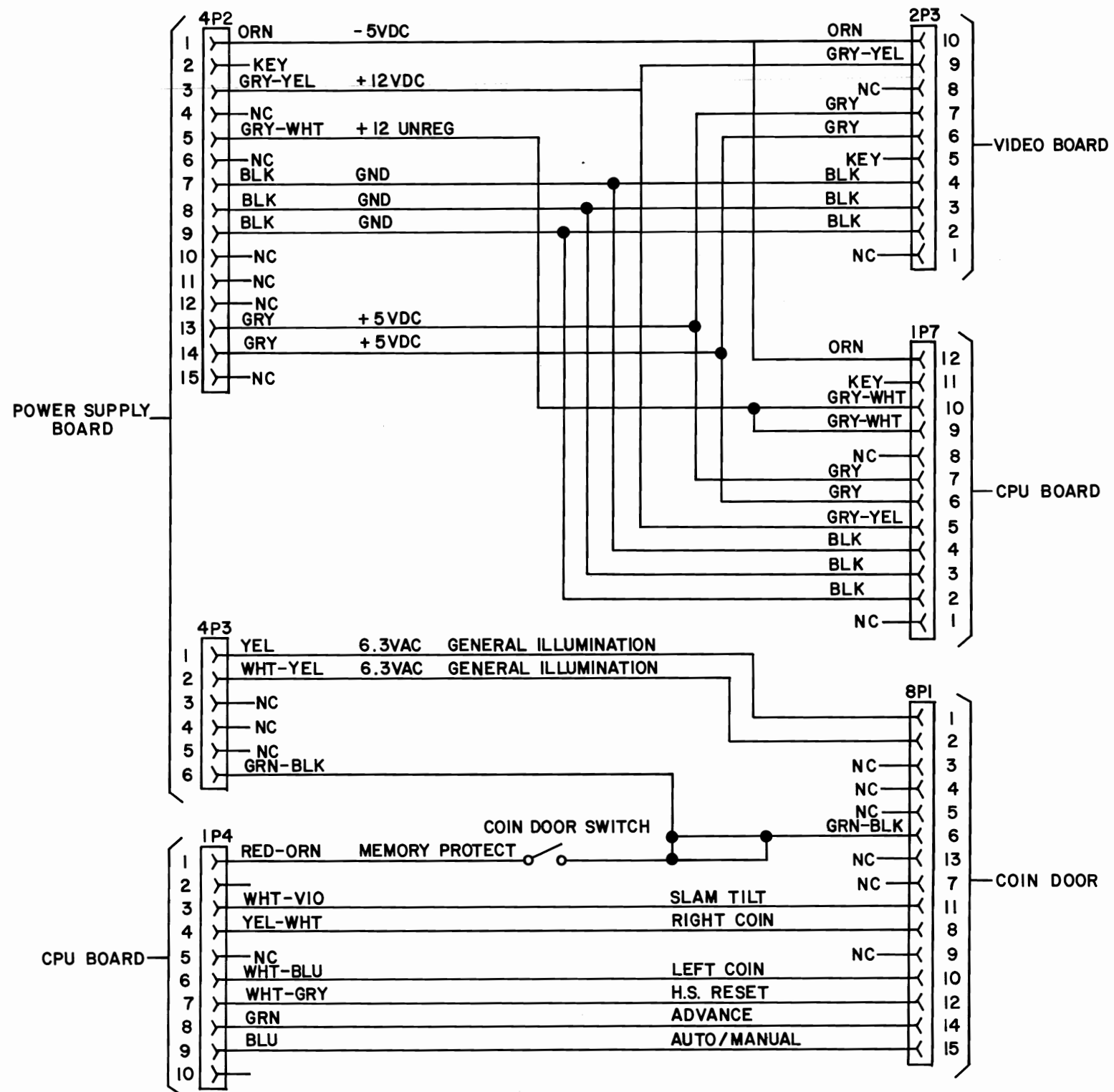

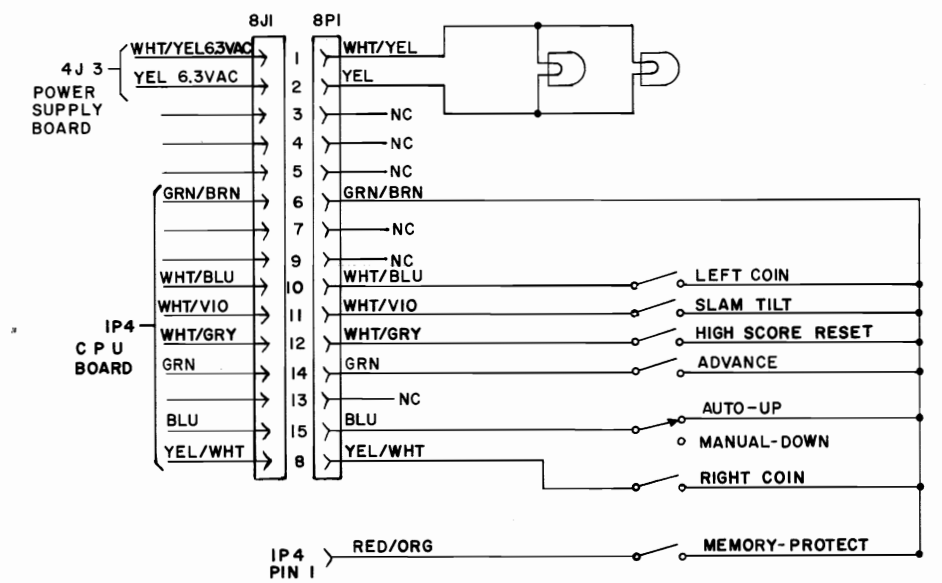
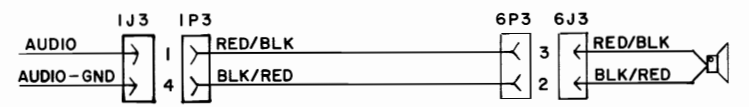
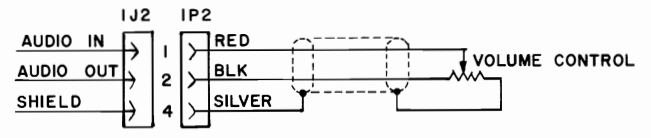
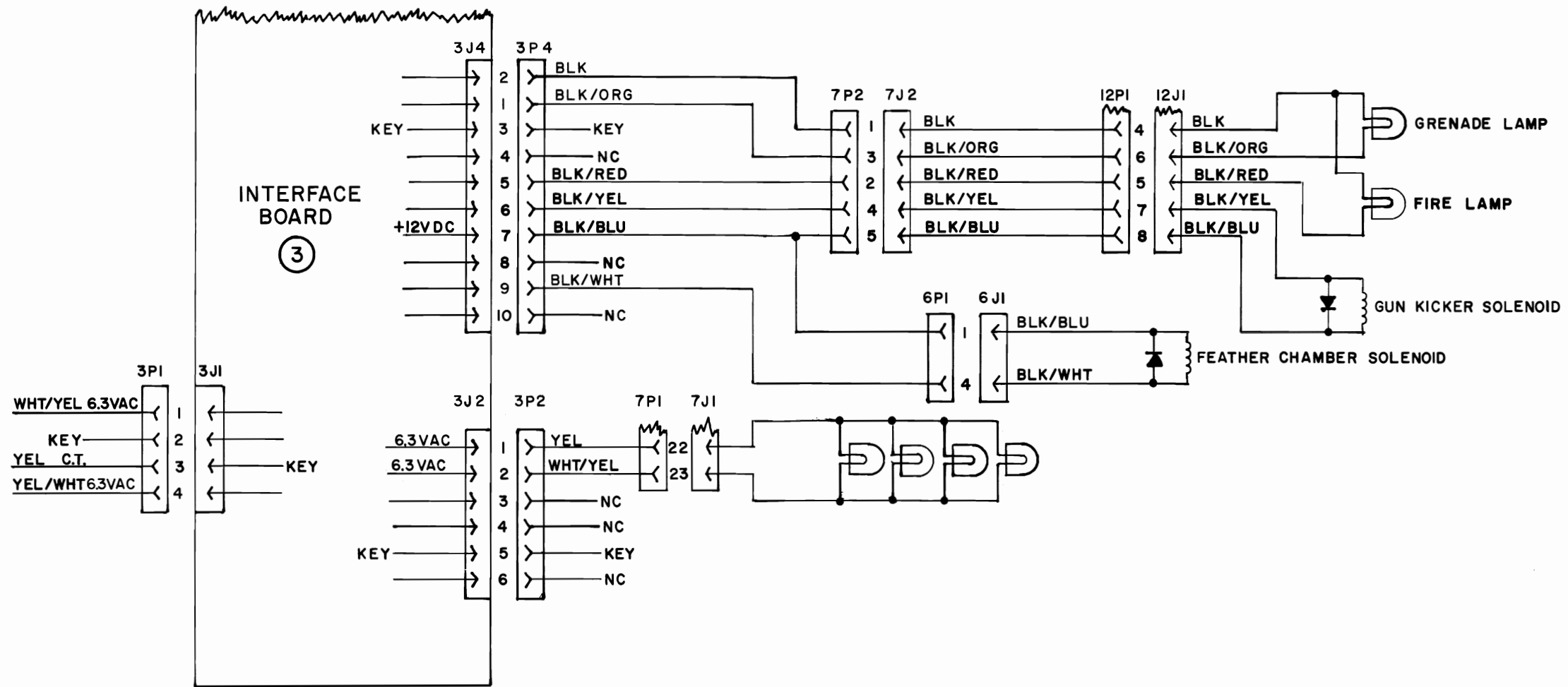

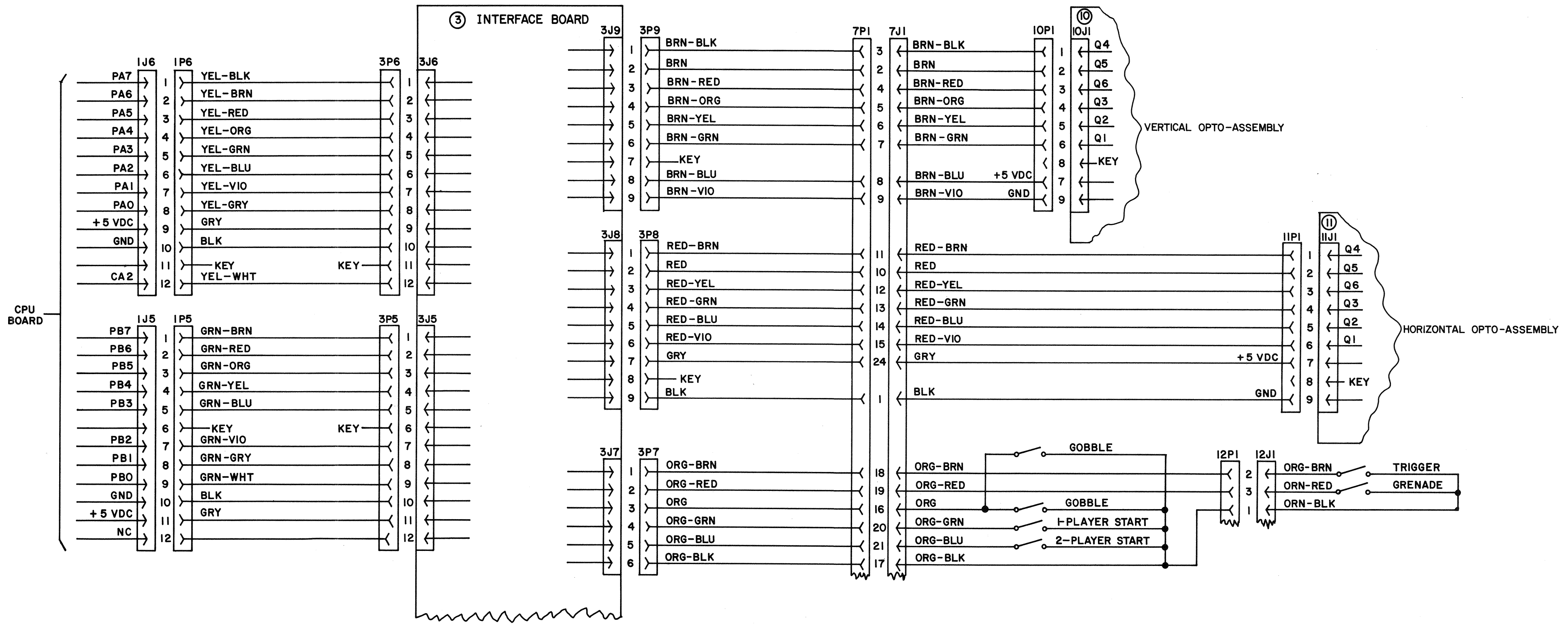

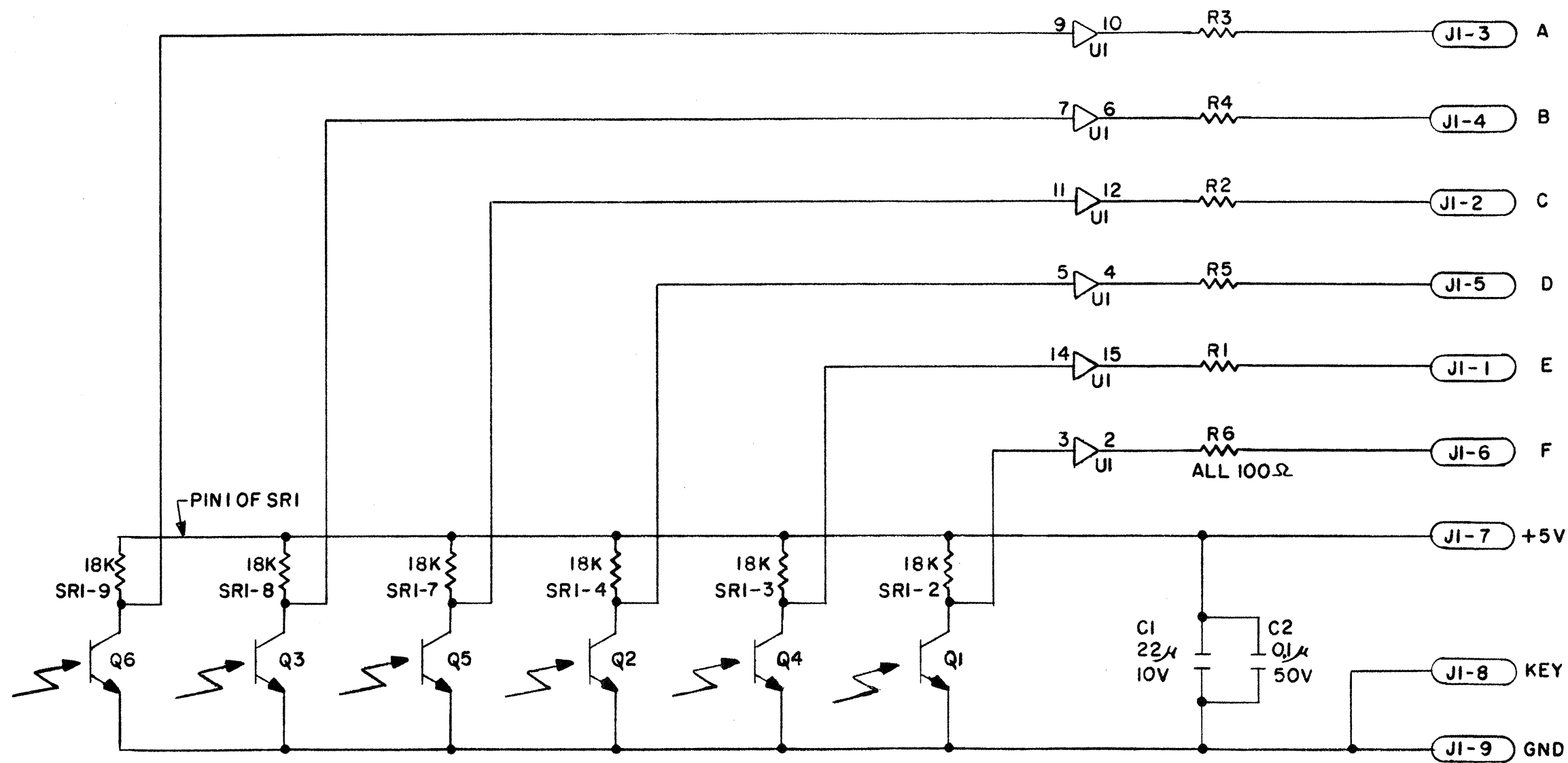

NOTE:

- I. +5 Vcc = PIN 1 OF UI
- GND = PIN 8 OF UI

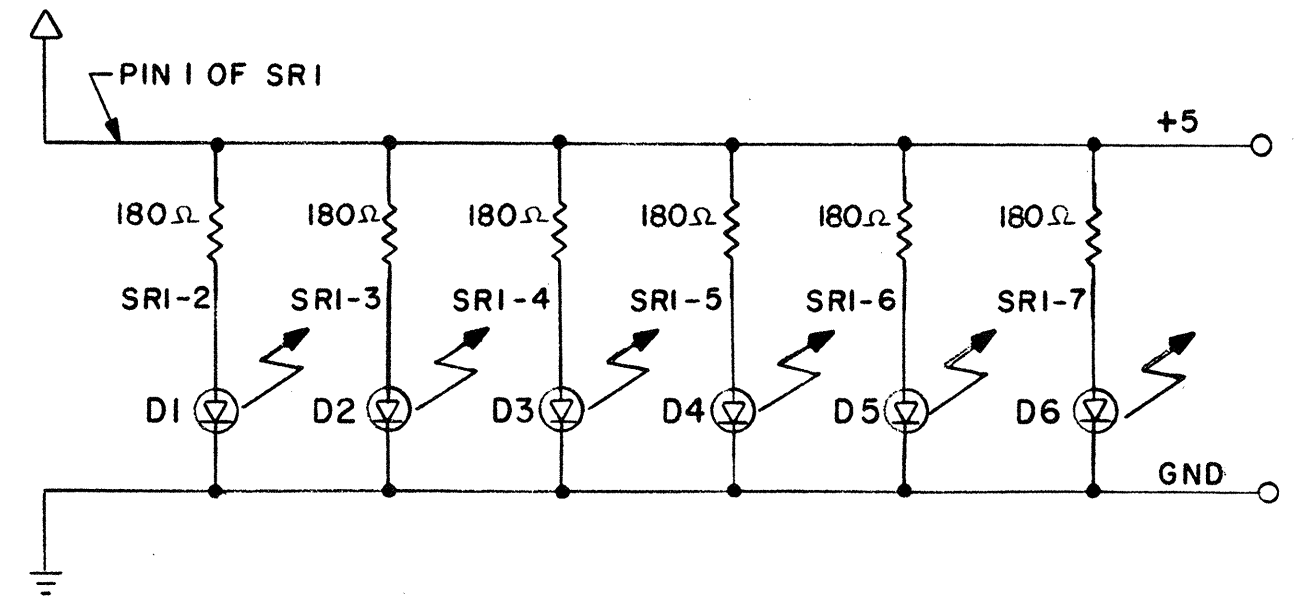

NOTE:

- I. POWER AND GROUND SUPPLIED THRU CENTER MOUNTING HOLES FROM ASSEMBLY C-10545

11	5010-09036-00	R1, R2, R3, R4, R5, R6	RESISTOR, C.F., 100 OHMS 5% 1/4 WATT	6
10	5310-09153-00	U1	I.C., 4050 HEX. BUFFER	1
9	16-8850-114		LABEL, PCB IDENT.	1
8	5791-09027-00	J1	CONNECTOR, 9 PIN MALE 2391 09-65-1091	1
7	5043-08996-00	C2	CAPACITOR, AXIAL, 0.1 MFD. 50V, +/-20	1
6	5040-09545-00	C1	CAPACITOR, AXIAL, 22 MFD. 10V, +/-20	1
5	5019-10158-00	SR2	SIP, 180 OHMS 7R 8P 5%	1
4	5019-10387-00	SR1	SIP, 18K OHMS 9R 10P 5%	1
3	5163-10509-00	Q1, Q2, Q3, Q4, Q5, Q6	PHOTOTRANSISTOR, NPN 3.4 mA	6
2	5671-10508-00	D1, D2, D3, D4, D5, D6	I. R. LED 40 mA .1 W	6
1	5779-10727-00		BARE P. C. BOARD (REV. A)	1
ITEM	PART NO.	PART DESIGNATION	DESCRIPTION	QTY

TURKEY SHOOT GUN ASS'Y. (D-10302)

ITEM	PART NO.	DESCRIPTION	QTY.
1	03-7890	GUN, MOLDED	1
2	B-10293	GUN SHAFT ASS'Y	1
3	03-7891-24	GUN NOZZLE	1
4	C-10423-3025-1	3025 BTN ASSY GRND	1
5	4106-01099-16B	S.T.S. #6 TORX (T-15) TRX-PH	2
6	4106-01099-18B	S.T.S. #6 TORX (T-15) TRX-PH	5
7	4106-01099-06B	S.T.S. #6 TORX (T-15) TRX-PH	1
8	4106-01099-26B	S.T.S. #6 TORX (T-15) TRX-PH	2
9	03-7786	P/GRIP TRIGGER	1
10	01-7994	T/S TRIG. SPRING	1
11	5647-10163-00	TRIGGER SWITCH	1
12	H-10328	GUN CABLE	1
13	4106-01009-06	SMS #6 x 3/8 P.PH P	4
14	A-10512	SKT. & BULB #1866 ASSY.	1
15	A-10441	COIL BRKT SUB-ASSY	1
16	01-7991	T/S COIL RET BRKT	1
17	02-4211	T/S KICKER PLUNGER	1
18	10-257	SPRING-CREDIT BTN	1
19	SFL-24/750-DC	3025 GUN COIL ASSY	1
20	23-6557-9	NEOPRENE GASKET	2
21	5791-09138-00	9P1625 03-06-2092	1
22	RM-23-01	H.S. TUBING 1/8 POLY	1

9-PIN MALE CONNECTOR

PIN	COLOR	FUNCTION
1	ORG-BLK	22 SW. GND
2	ORG-BRN	22 TRIGGER SW.
3	ORG-RED	22 GRENADE SW.
4	BLK-RED	22 LAMP COMMON 6V D.C.
5	BLK-RED	22 TRIGGER LAMP ON-OFF
6	BLK-ORG	22 GRENADE LAMP ON-OFF
7	BLK-YEL	18 TRIGGER SOLENOID ON-OFF
8	BLK-BLU	18 SOLENOID COMMON (+12V D.C.)
9	NOT USED	

WHITE HOUSING 5791-09138-00 (REF.). Install item 21 after wires are installed in gun shaft.

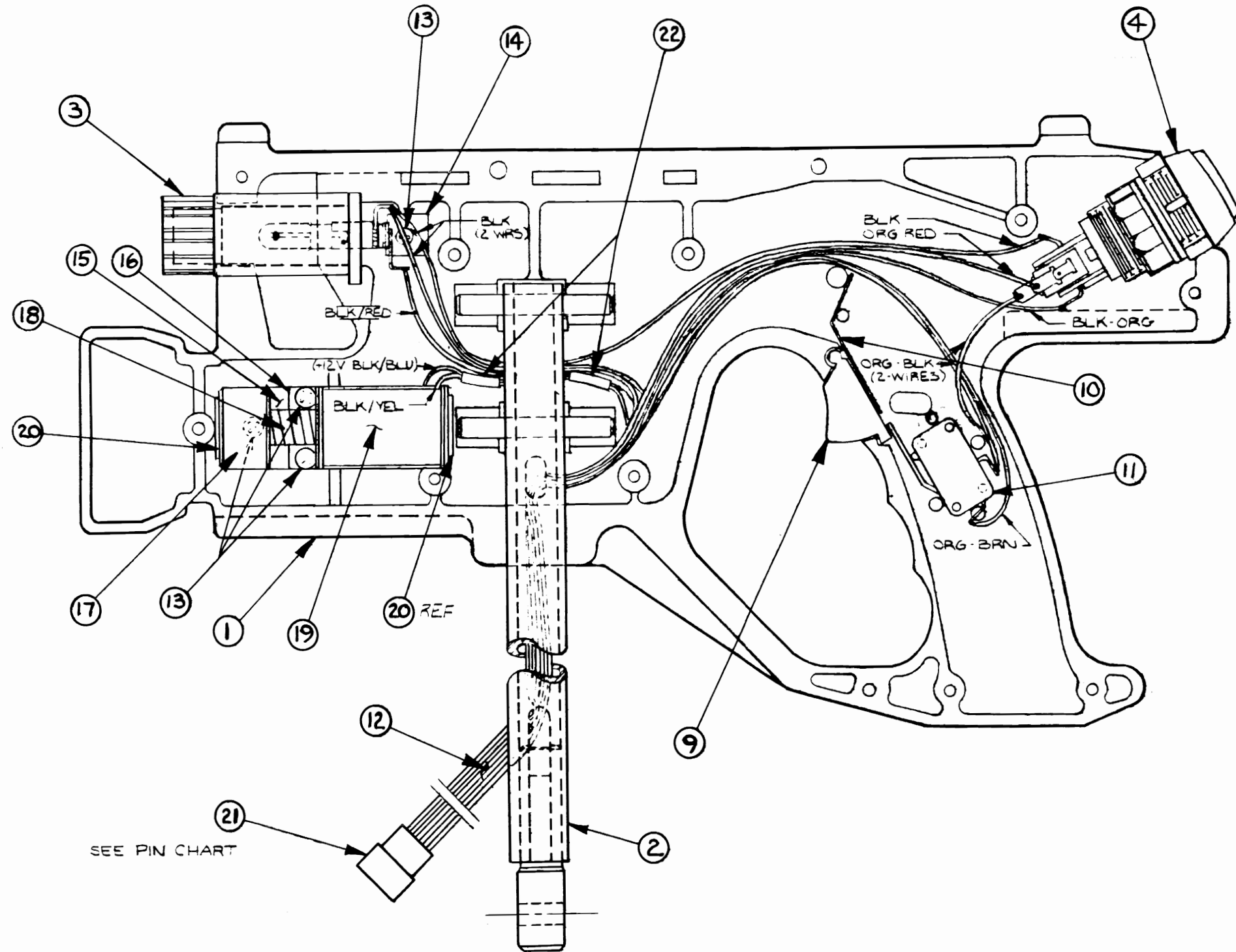

FEATHER CHAMBER ASSY. (D-10344)

ITEM	PART NO.	DESCRIPTION	QTY.
1	11-768	FTR DEVICE FRAME	1
2	01-7906	F/D GLASS CLAMP	2
3	4206-01016-08	WS #6 x 1/2 P-RH	4
4	03-7902	FTR DEVICE SCREEN	1
5	4208-01041-10	WS #8 x 1/2 P-FH	6
6	01-7927	FEATHER GUIDE	2
7	01-7979	F/D FLOW DIVIDER	1
8	31-1228-3025-U	3025 F/D COVER	1
9	08-7424	FTR DEVICE GLASS	1
10	20-9435	FEATHERS	80
11	23-6573-4	NEOPRN GSKT 17"	2

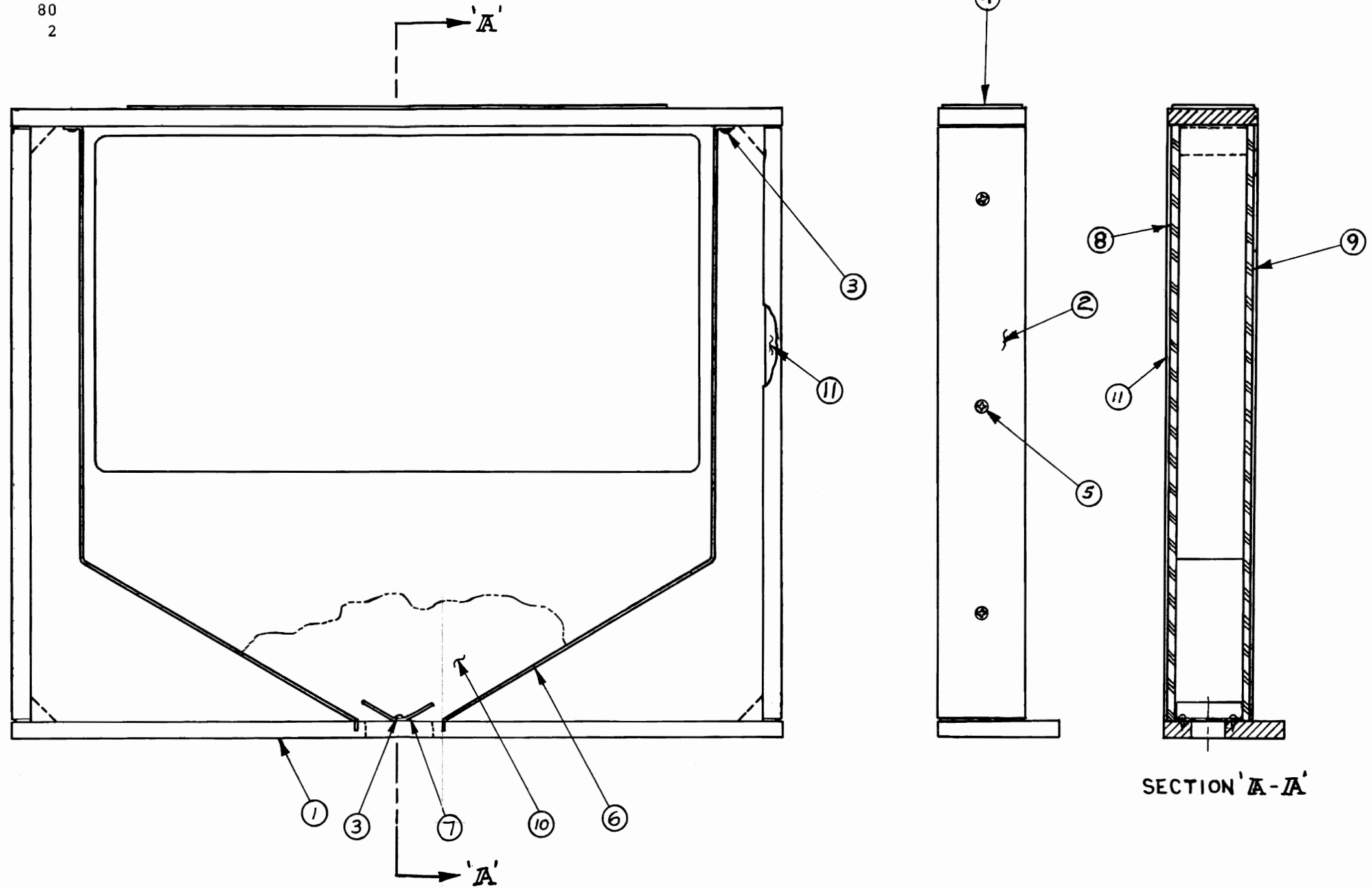

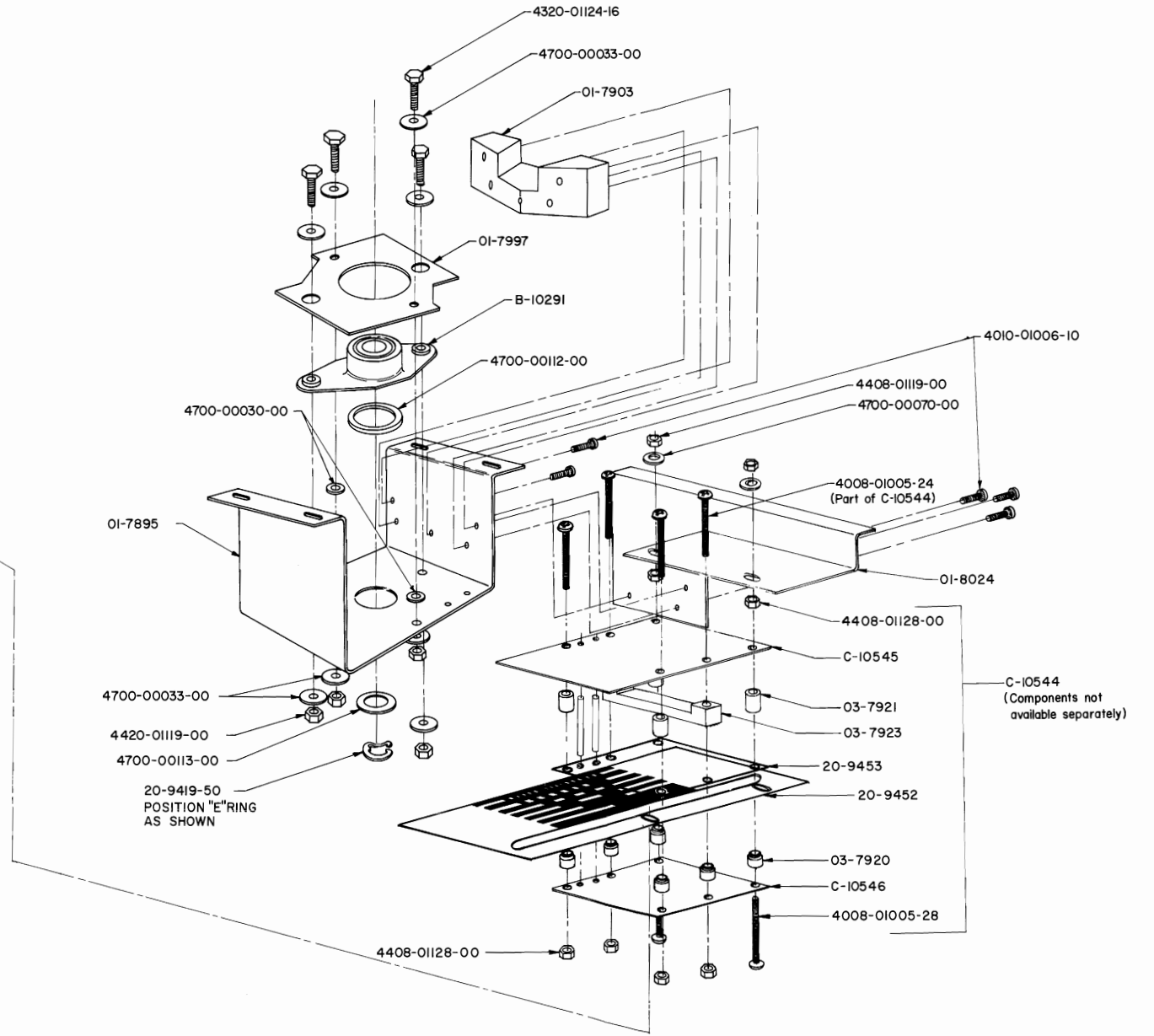
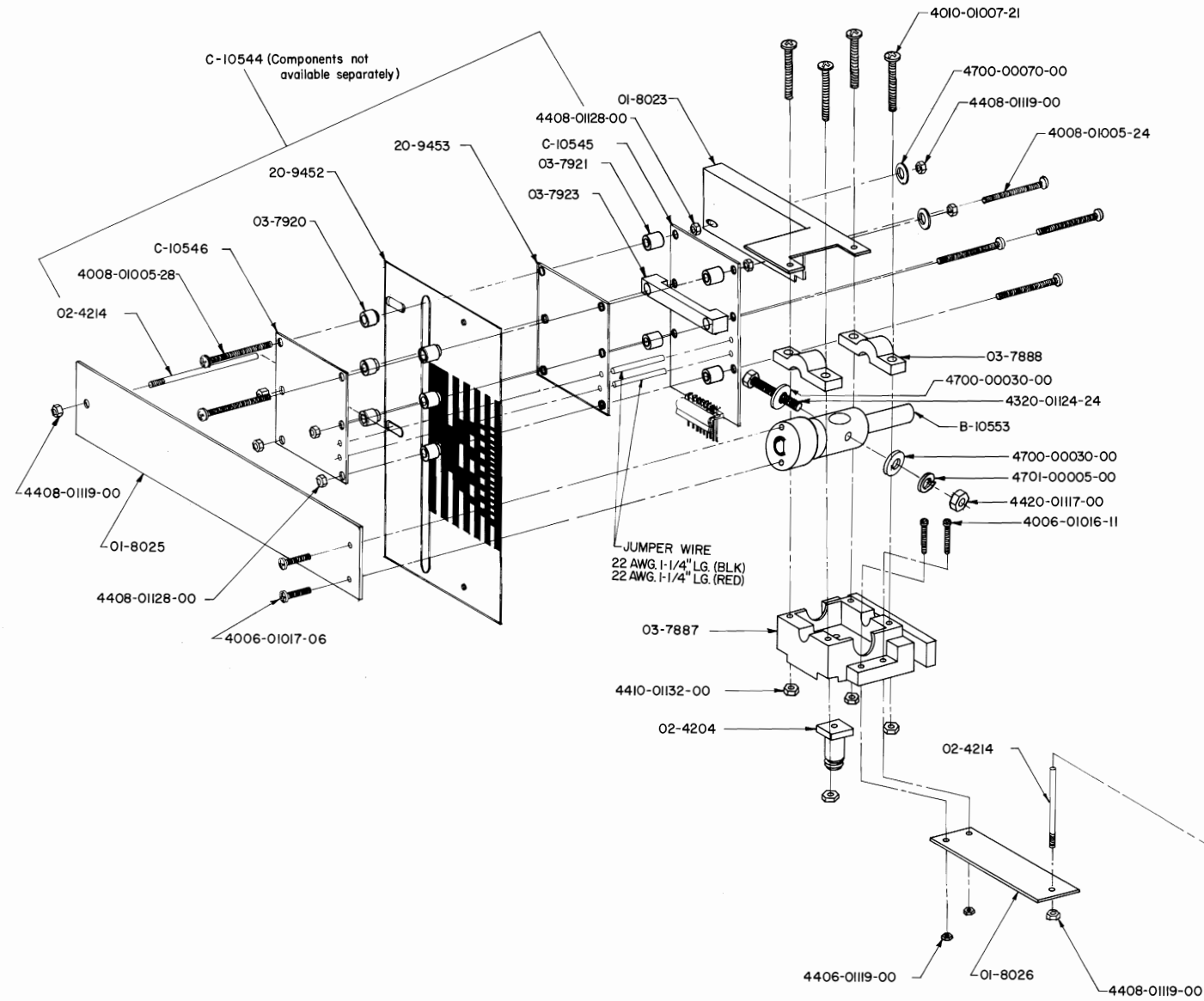

MALE CONNECTORS AND FEMALE RECEPTACLES

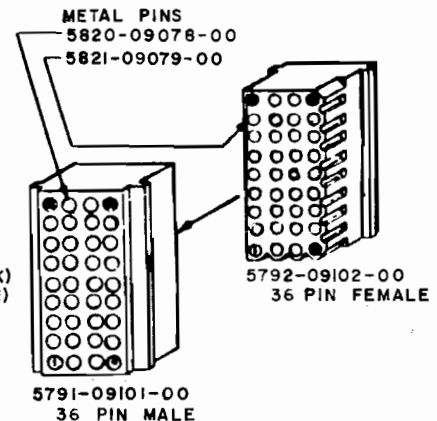
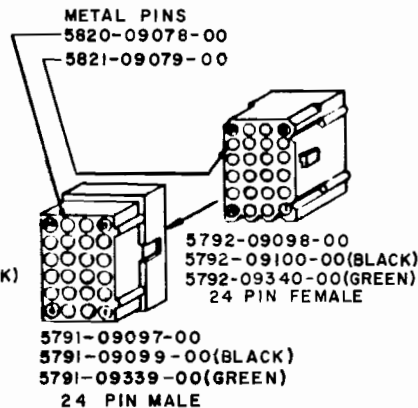
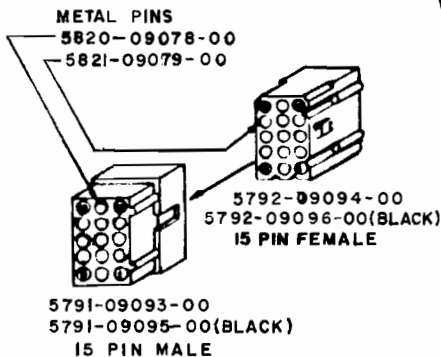
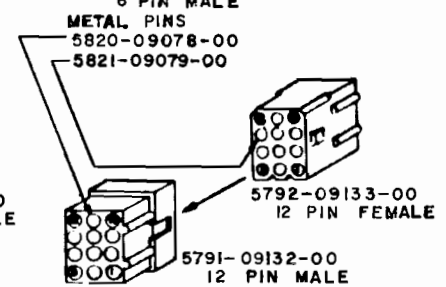
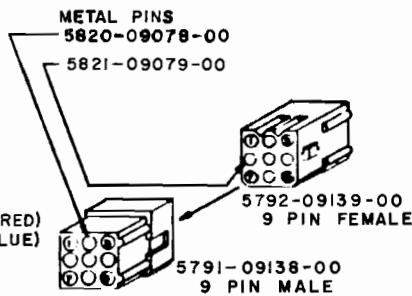
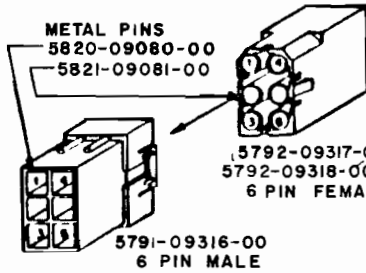
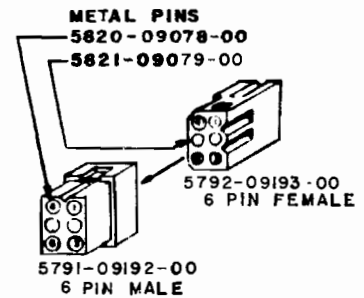
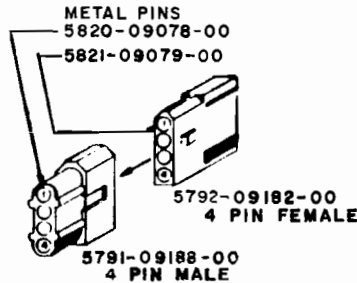
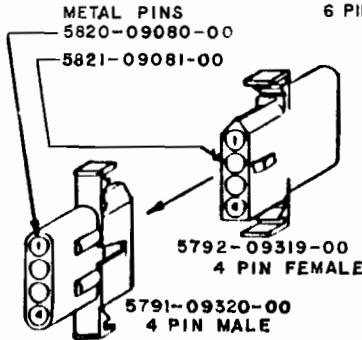
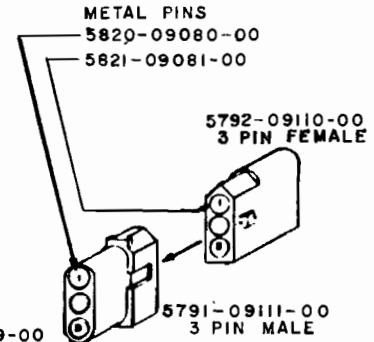
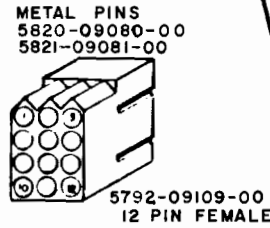
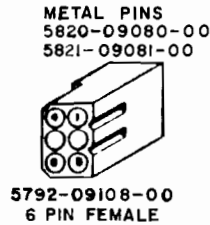
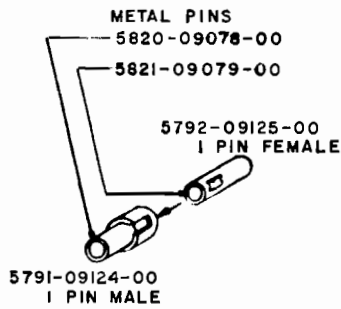
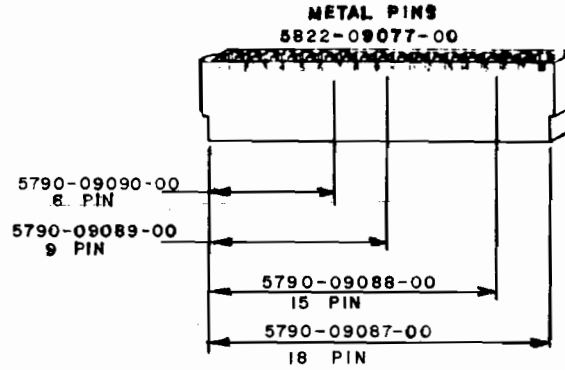
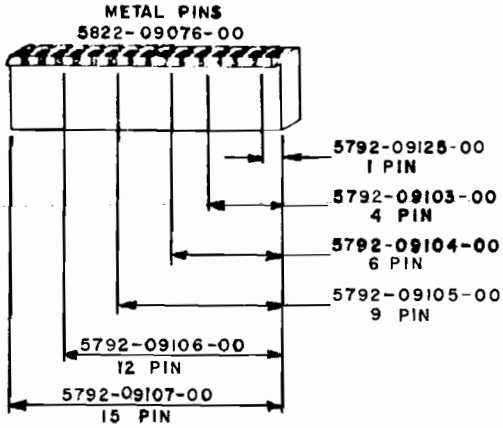

BLANKING

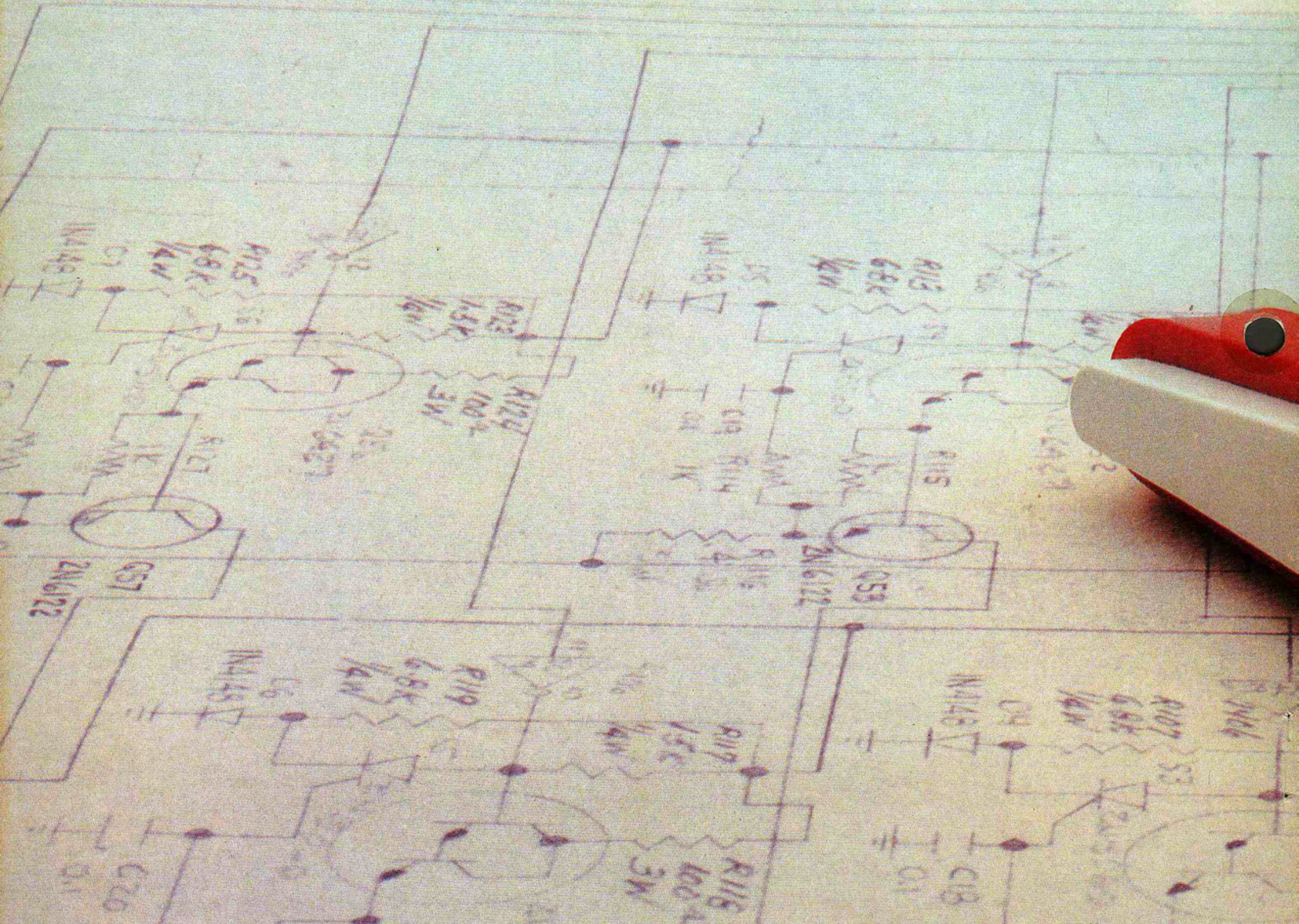

For Service...
Call your authorized
WILLIAMS distributor

Williams[®]
ELECTRONICS, INC.
3401 N. California Ave., Chicago, IL 60618
(312) 267-2240, Telex 253095