



AUGUST 1998
16-30024-101

VAPOR TRX



SIT-IN DEDICATED GAME 25" (63 cm) COLOR MONITOR OPERATION MANUAL

Operation & Adjustments • Testing & Problem Diagnosis
Parts Information • Wiring Diagrams

WARNINGS & NOTICES

WARNING

USE OF NON-ATARI PARTS OR CIRCUIT MODIFICATIONS MAY CAUSE SERIOUS INJURY OR EQUIPMENT DAMAGE! USE ONLY ATARI AUTHORIZED PARTS.

* For safety and reliability, substitute parts and modifications are not recommended.

* Substitute parts or modifications may void FCC type acceptance.

* Use only authorized components and parts. Failure to do so will void warranty and may result in incorrect and/or unsafe operation.

* This game is protected by federal copyright, trademark and patent laws. Unauthorized modifications may be illegal under federal law. This also applies to ATARI logos, designs, publications and assemblies. Moreover, facsimiles of ATARI equipment (or any feature thereof) may be illegal under federal law, regardless of whether or not such facsimiles are manufactured with ATARI components.

TABLE OF CONTENTS

Section One - Operation

| | |
|--|------|
| Safety Notices | 1-2 |
| Product Specifications | 1-3 |
| Product Configuration | 1-3 |
| Inspection and Installation | 1-4 |
| Maintenance | 1-7 |
| Service | 1-8 |
| Game Operation | 1-20 |
| Game Rules | 1-21 |
| Game Play | 1-21 |
| Game Features | 1-22 |
| Starting-Up | 1-22 |
| Player Controls | 1-24 |
| Operator Controls | 1-25 |
| Operator Control Location Diagram | 1-25 |
| Power On Tests | 1-26 |
| Self Test Menu System Operation | 1-27 |
| System Overview | 1-27 |
| Screen Layout | 1-27 |
| Organization | 1-27 |
| Volume Adjustment | 1-28 |
| Statistics | 1-29 |
| Game Options | 1-30 |
| Coin Options | 1-31 |
| Controls Test | 1-32 |
| Sound Tests | 1-33 |
| Memory Tests | 1-34 |
| Monitor Tests | 1-35 |
| Disk Tests | 1-36 |
| Network Tests | 1-37 |
| Linked Operation | 1-38 |
| Equipment Requirements | 1-38 |
| Head-to-Head Racing | 1-38 |
| Switches and Jumpers | 1-39 |
| Errors | 1-39 |

Section Two - Parts Information

| | |
|--|------|
| Main Cabinet and Seat Assembly – Front View..... | 2-2 |
| Main Cabinet and Seat Assembly – Rear View..... | 2-3 |
| Seat Module Assembly | 2-4 |
| Caster/Leveler Kits..... | 2-5 |
| Flight Control Assembly | 2-6 |
| Dash Panel Assembly | 2-7 |
| Steering Mechanism` | 2-8 |
| Coin Door Assembly | 2-9 |
| Coin Door Application Chart..... | 2-9 |
| Power Supply Assembly..... | 2-10 |
| Line Cord Application Chart | 2-10 |
| Rear Door Locking Hasp Assembly | 2-11 |
| Rear Door Assembly | 2-11 |
| Electronics Assembly | 2-12 |
| CPU Board Assembly | 2-13 |
| Sound Sub-Woofers Assembly | 2-14 |
| Wheel Driver Board Assembly | 2-15 |
| ADC/AUX Widget Board Assembly | 2-16 |
| Other Parts Necessary | 2-17 |

Section Three - Cabinet Wiring

| | |
|---|------|
| Edge Connector Chart..... | 3-2 |
| Cabinet Wiring Diagram..... | 3-3 |
| Power Wiring Diagram | 3-4 |
| Dollar Bill Validator Wiring | 3-5 |
| Electronic Currency Acceptor Wiring..... | 3-5 |
| CPU Board Indicator and Switch Locations | 3-6 |
| CPU Board Jumper Status Chart..... | 3-7 |
| CPU Switches..... | 3-8 |
| CPU Board LED Indicator Status Chart | 3-8 |
| Wheel Driver Board LED Indicator Status Chart..... | 3-10 |
| ADC/AUX Widget Board LED Status Indicator Chart... .. | 3-11 |

Section Four - Troubleshooting

| | |
|-------------------------------|-----|
| Game Does Not Start..... | 4-2 |
| Game Can Not Be Played..... | 4-3 |
| Linking Problems | 4-5 |
| Player Control Problems | 4-6 |
| Audio Problems | 4-7 |
| Video Problems | 4-8 |
| Miscellaneous | 4-9 |

© Copyright 1997 ATARI Games Corporation All rights reserved.

VAPOR TRX™

SECTION ONE

OPERATION

NOTICE

Information in this manual is subject to change without notice. ATARI reserves the right to make improvements in equipment function, design, or components as progress in engineering or manufacturing methods may warrant.

Fill out and mail in the Game Registration card. Include the game serial number from the label on the rear of the cabinet. For your records, write the game serial number in the manual. SERIAL NUMBER _____

SAFETY NOTICES

The following safety instructions apply to all game operators and service personnel. There are specific warnings and cautions throughout this manual where they apply. Read this page before preparing your game for play.



HARD DISK DRIVE. The hard disk drive must be packed in an anti-static bag. The disk drive assembly must be packed in an approved shipping container (P/N 08-8068) in order to be sent in for repair or replacement. Do not stack or drop hard disk drives during installation or removal.

TRANSPORTING GAME. This game contains glass and fragile electronic devices. Transport this game securely. Avoid rough handling when moving cabinet. Do not move this game with power on.

AC POWER CONNECTION. Verify that the switch on the power supply is set for 110VAC or 220VAC according to local line voltage. Verify that the fluorescent lamp assembly is correct for local line voltage.

PROPERLY GROUND THE GAME. To avoid electrical shocks, do not plug in the game until it has been inspected and properly grounded. This game should only be plugged into a fixed-location grounded 3-wire outlet. Do not use a "cheater" plug or cut off the ground pin on the line cord.

POTENTIAL SHOCK HAZARD. This video game system does not utilize an isolation transformer. There is no isolation between the internal cabinet AC system and the external AC line.

DISCONNECT POWER DURING REPAIRS. To avoid electrical shock, turn off the power switch and disconnect the game from the AC power source before removing or repairing any part of the game. After servicing any parts of the unit, be sure that all of the ground wires are secure before restoring power.

PROPERLY ATTACH ALL CONNECTORS. Be sure that the connectors on each printed circuit board (PCB) are properly connected. If they do not slip on easily, do not force them. A reversed connector may damage your game and void the warranty. Connectors are keyed to fit specific pins on each board.

USE PROPER FUSE. To avoid electrical shock, all replacement fuses must match the type, voltage rating, and current rating of the original fuse.

HANDLE FLUORESCENT TUBE AND CRT WITH CARE. If you drop a fluorescent tube or CRT and it breaks, it will implode! Shattered glass can fly eight feet or more from the implosion.

EPILEPSY WARNING

A very small portion of the population has a condition which may cause them to experience epileptic seizures or have momentary loss of consciousness when viewing certain kinds of flashing lights or patterns that are present in our daily environment. These persons may experience seizures while watching some kinds of television pictures or playing certain video games. People who have not had any previous seizures may nonetheless have an undetected epileptic condition.

If you or anyone in your family has experienced symptoms linked to an epileptic condition (e.g., seizures or loss of awareness), immediately consult your physician before using any video games.

Parents should observe their children while they play video games. If you or your child experience the following symptoms: dizziness, altered vision, eye or muscle twitching, involuntary movements, loss of awareness, disorientation, or convulsions, **DISCONTINUE USE IMMEDIATELY** and consult your physician.

PRODUCT SPECIFICATIONS

Operating Requirements

| <u>Location</u> | <u>Electrical Power</u> | <u>Temperature</u> | <u>Humidity</u> |
|-----------------|-------------------------|--------------------|----------------------------|
| Domestic | 120VAC @ 60Hz 4.0 Amps | 37°F to 100°F | Not to exceed 95% relative |
| Foreign | 230VAC @ 50Hz 2.0 Amps | (3°C to 38°C) | |
| Japan | 100VAC @ 50Hz 4.0 Amps | | |

Cabinet Statistics

| <u>Shipping Dimensions</u> | <u>Shipping Weight</u> | <u>Design Type</u> |
|----------------------------|------------------------|--|
| Width 35.0" (88.9 cm) | 326 lbs. (148.2 kg.) | Single Sit-In Dedicated Video Game with Linking capability |
| Depth 37.5" (95.3 cm) | | |
| Height 76.0" (193 cm) | | |

Seat Statistics

| <u>Shipping Dimensions</u> | <u>Shipping Weight</u> |
|----------------------------|------------------------|
| Width 15.0" (38.1 cm) | 57 lbs. (25.9 kg.) |
| Depth 30.0" (76.2 cm) | |
| Height 17.0" (43.2 cm) | |

Equipment Characteristics

| <u>Video Display Monitor</u> | <u>Audio System</u> | <u>Currency Acceptors</u> |
|------------------------------|-----------------------|------------------------------|
| Standard Resolution RGB | 3 Channel Audio | Standard Coin Door |
| 27" (68.5 cm) CRT | 2 Full Range Speakers | 2 Coin Mechanisms, DBV ready |
| | 1 Subwoofer | 1 Coin Counter |

Game Characteristics

| <u>Player Variables</u> | <u>Operator Variables</u> | <u>Diagnostics</u> |
|--|--|---|
| 1 to 8 players per game (with Linking) | Coinage, Play Mode, Difficulty, Volume, Audits, Statistics | Automatic Power-Up Test Manual Multi-Level Menu System |
| Choice of vehicle style, track | | |
| Fastest Track Time Recognition | | |

PRODUCT CONFIGURATION

◆ Stand Alone Units

Each game is ready to play right out of the box. Operators may use the menu screens in the game menu system to determine some player variables in advance or leave the choices up to the players.

◆ Linked Units

Linking allows players to compete against each other (on one track). Operator menus are the same as in stand-alone games. Basic Kits connect together two cabinets electrically and mechanically. Use the optional Hub Linking Kit to interconnect up to eight games.

INSTALLATION AND INSPECTION

1. Remove all items from shipping containers and set aside. Casters, levelers, and mounting hardware are packed with the seat assembly. Inspect the exterior of the cabinet for any signs of damage.
2. Remove the keys from the steering mechanism. Unlock and open the coin and cash box doors. Electrical cords and spare parts are stored in the cash box.
3. Install one nut onto each leg leveler. Tilt as needed to locate four threaded holes under the cabinet and three under the pedestal. Install a leveler and nut into each hole. Do not tighten nuts at this time.



WARNING
The cabinet is top heavy.

4. Locate the caster wheel assemblies. Lay cabinet on its back or side and attach one caster onto each group of threaded studs. The cabinet uses four swivel casters, one in each corner.

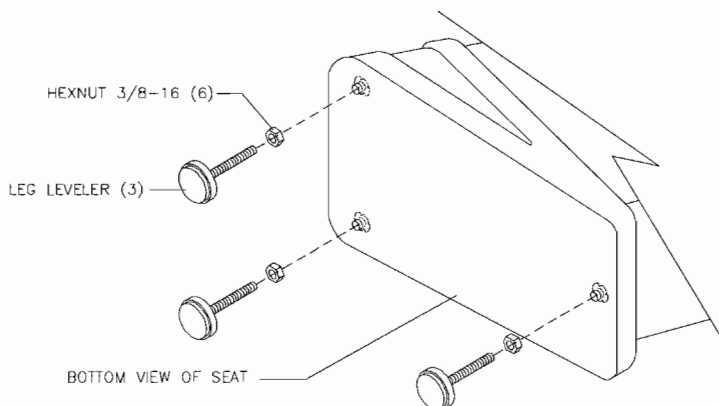
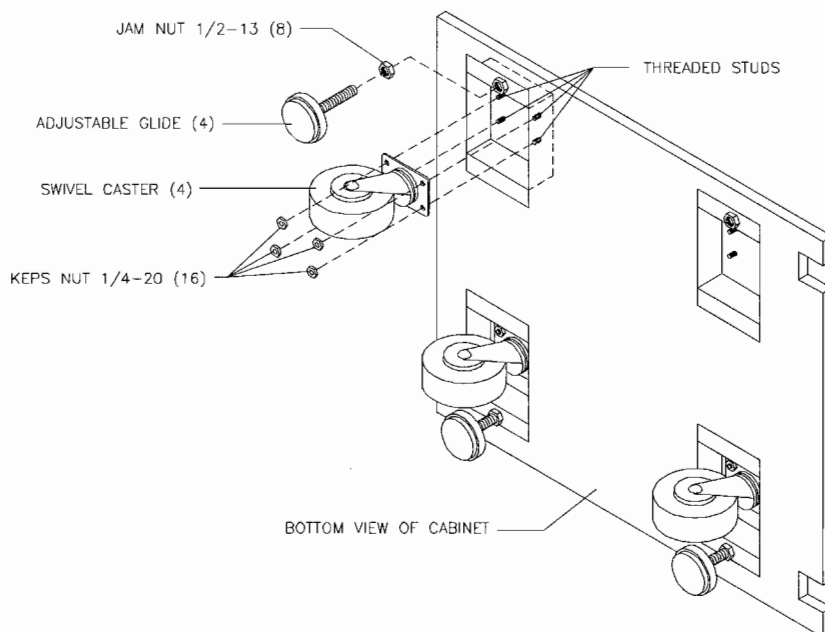

LOCATION OF CASTERS AND LEG LEVELERS UNDER CABINET AND SEAT

5. Stand cabinet upright and make certain it is in a stable position. Move the game to its intended location and level the cabinet. This game is intended for use only in a fixed position. Ensure that the final adjustment raises the game so that the swivel caster wheels are not touching the floor. Distribute weight equally on each corner and tighten the leveler nuts.
6. Turn the seat upside down and attach the leveling legs to the bottom. Return the seat to its upright position, then align the openings in the seat mounting brackets with the threaded inserts in the seat and cabinet base. Slide the seat forward to align the holes. Attach the seat assembly using 1/4-20 tamper-resistant screws, hex-head bolts, and large flat washers. A T27 wrench is included with the spare parts to tighten these screws firmly. Tighten the hex-head bolts on the upper seat mounting bracket after tightening the tamper-resistant screws on the lower bracket. Adjust the seat leveling legs and secure them with the locking nuts.
7. Remove the rear door of cabinet. Inspect cabinet interior for any signs of damage. Check all major assemblies to assure that they are mounted securely. Ensure that nothing blocks fan airflow.
8. An extra padlock may be installed to secure the rear door. The spare parts bag includes a hasp. Remove the two lock bracket nuts from inside the cabinet, above the rear door opening. Slide the hasp onto the bolts so that it protrudes from the hole in back of the cabinet, and then reinstall the nuts.
9. Modify the lock plate at the top of the rear door. Remove the bolts and nuts from the lock plate, then rotate the plate so that the slot will be above the door. Reinstall the bolts and nuts and tighten firmly.

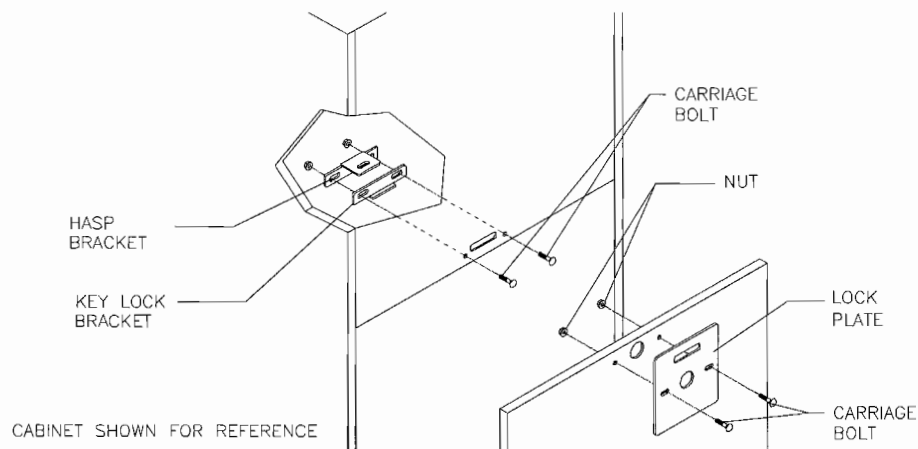

HASP BRACKET AND LOCK PLATE ASSEMBLY INSTALLATION

10. The power cord is stored with the spare parts. Match the holes on the IEC plug with the prongs in the receptacle and push firmly to seat the line cord.

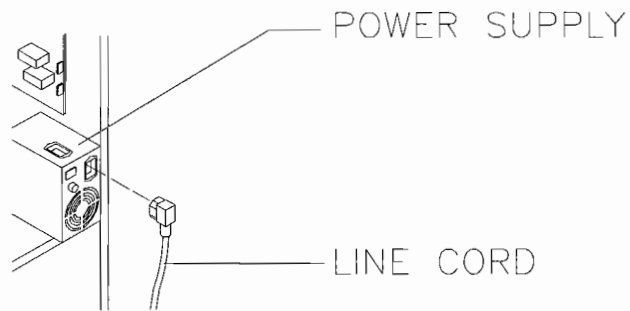

LINE CORD INSTALLATION

11. Refer to the game's Cabinet Wiring Diagram (Section Three of this manual) and check to see that all cable connectors are correctly secured. Inspect for damaged connectors. Be sure **NOT TO FORCE CONNECTORS** and avoid making reversed connections.
12. Plug the game into a grounded (3-terminal) AC wall outlet. Switch **ON** the game using the **ON/OFF** switch located on the power supply. The game will power up and begin self-diagnostics. If there are no errors, the game will automatically enter its "attract" mode of operation.

MAINTENANCE

◆ Viewing Glass

Remove the four T-25 screws holding the viewing glass retaining strip in place. Firmly push the retaining strip upward to clear it of the dashboard molding. Set the retainer strip aside. Slide the glass up and out of the groove, then pull it forward from its bottom edge to remove it from the cabinet.

◆ Cabinet

Use plastic-safe non-abrasive cleaners to avoid damage. Apply cleaner to a clean cloth or sponge, then use this to wipe the controls or cabinet. *Do not apply cleaner directly on controls or cabinet!*

SERVICE

Only qualified service personnel should perform maintenance and repairs. The product guidelines apply to all game operators and service personnel. There are specific notes, cautions, and warnings throughout this manual where they apply. Read the SAFETY pages thoroughly before beginning service.

This game uses complex electronic components that are very SENSITIVE to static electricity. Observe and follow these precautions prior to handling the game electronics:

1. Ensure that the A.C. power to the game is turned OFF prior to servicing the electronics.
2. Discharge any static electricity build up in your body by touching the metal power supply chassis. Do this BEFORE touching or handling the electronic assemblies.
3. Store the electronic assemblies in an anti-static area. Use anti-static bags to store or transport the hard disk drive, the CPU Board Assembly, and all other electronics.
4. DO NOT remove or connect any electronic assemblies when the cabinet power is ON. Doing so will damage the electronic assemblies and void the warranty.
5. Always replace ground wires, shields, covers, etc., when maintenance or service is completed.

◆ Marquee

Remove six hex-head wood screws holding the marquee housing to the marquee-retaining strip. Remove the three hex-head wood screws holding the marquee-retaining strip to the cabinet. Hold the glass in place to avoid breakage. Remove the retaining strip and set it aside. Lift the marquee glass out of the groove and set in a safe place. Do not over tighten screws during re-installation.



WARNING

The marquee glass could fall out of the cabinet and break when the retaining strip is removed.

◆ Fluorescent Lamp and Starter

Remove the marquee housing, retaining strip, glass, and artwork. Grasp the tube, give it a quarter turn and pull it from its sockets. The starter also requires a quarter turn for removal or installation. Carefully place a new tube into the socket and rotate it a quarter turn to reinstall. Clean the tube to remove fingerprints and dust.



WARNING

If a fluorescent tube drops and breaks, it will implode and shatter glass! Use care in handling.

◆ Fluorescent Light Assembly

Remove the marquee housing, retaining strip, glass, and artwork. Disconnect the power cable from the fluorescent light assembly. Loosen but do not remove the screws fastening the assembly to the cabinet. Slide the assembly slightly forward to disengage the keyholes. Lift out the assembly.

◆ Dash Board

Mark and disconnect the wiring harnesses. Use the T27 wrench to remove four tamper-resistant screws at the dashboard front corners. Loosen, but do not remove, the four screws holding the viewing glass retaining strip. Slide the retaining strip upward and hold it in place. Pull the dashboard forward. Before reinstalling the dashboard, ensure that harnesses are reconnected.

STEERING MECHANISM DETAIL
 BELT TENSION ADJUSTMENT
 (LOOSEN ALL MOUNTING NUTS
 TO ADJUST BELT TENSION)

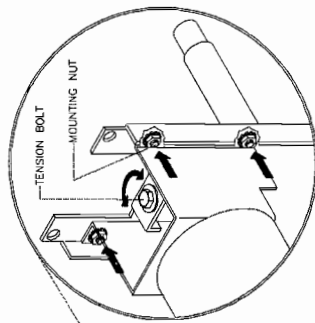

STEERING MECHANISM
 (SEE DETAIL DRAWING)

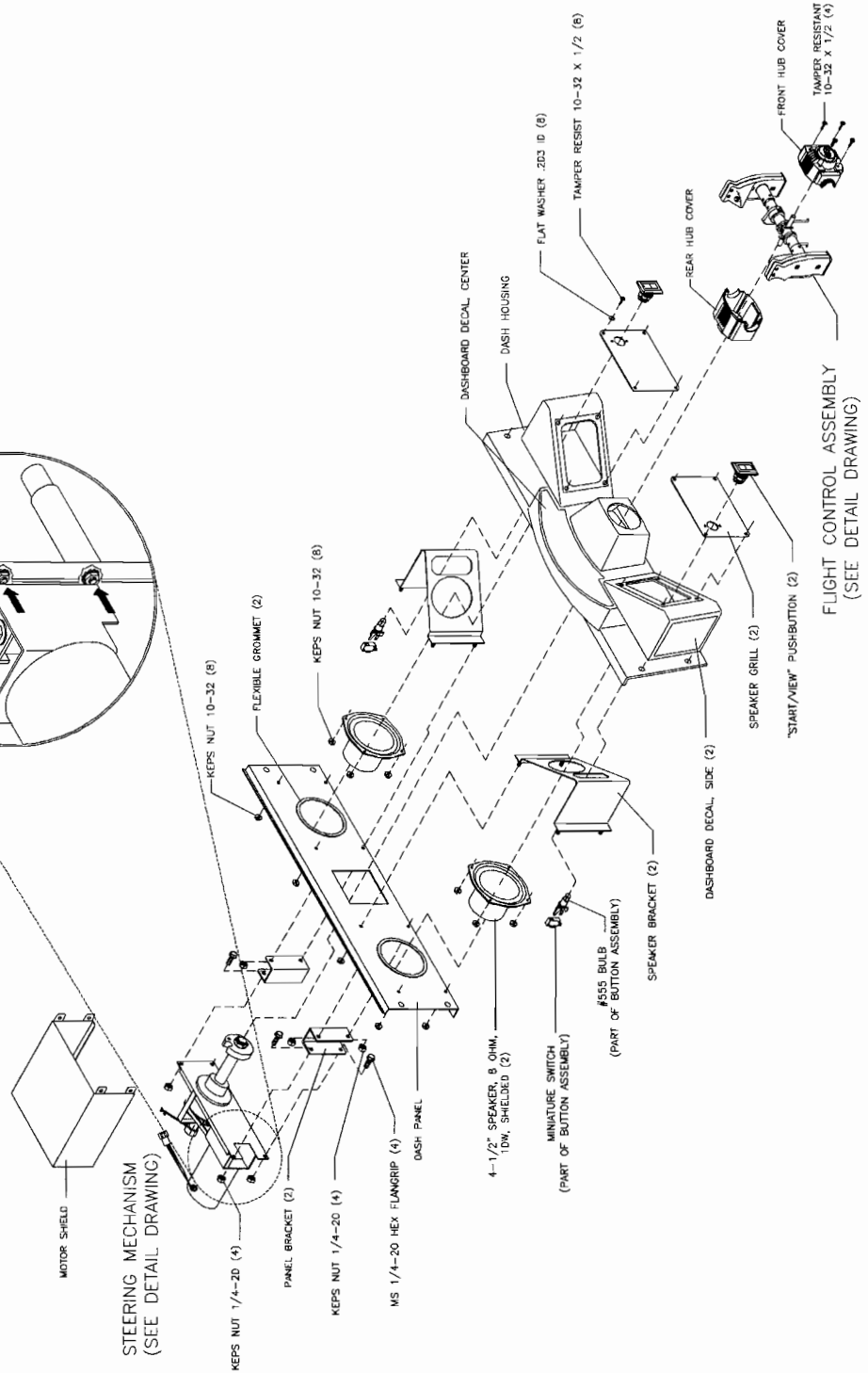

FLIGHT CONTROL ASSEMBLY
 (SEE DETAIL DRAWING)

FLIGHT CONTROL AND DASH BOARD ASSEMBLY DIAGRAM

◆ **Flight Control Assembly**

Remove the dashboard. Place the dashboard assembly on a workbench in a safe area. Remove four screws holding the cover to the center of the flight control assembly handles. Remove the cover to expose the stop braces. Remove the tamper-resistant screws at each end of the stop braces to free them from the mechanism. Remove the four T-27 tamper-resistant screws holding the flight control assembly pivot housing to the motor mechanism shaft flange. Pull the handles away from the flange just enough to expose the wiring harnesses. Support the motor mechanism and remove four ¼-20 KEPS nuts holding the shield, motor and shaft to the dash panel. Slide the motor and the shaft off the dash panel. Remove the cable tie holding the wiring harness to the shaft. When reassembling, remember to replace the cable tie and to carefully replace the harnesses to avoid cable damage.

IMPORTANT: Apply removable anaerobic adhesive thread lock (Loctite Blue 242 or equivalent) and torque cap screw to seven to nine ft.-lbs (84 to 108 in.-lbs) if it was loosened (see illustration).

While the flight control assembly is exposed, inspect the belt. Install a new belt if the existing one is loose or shows signs of wear at the edges of the teeth. Remember to calibrate after re-installation.

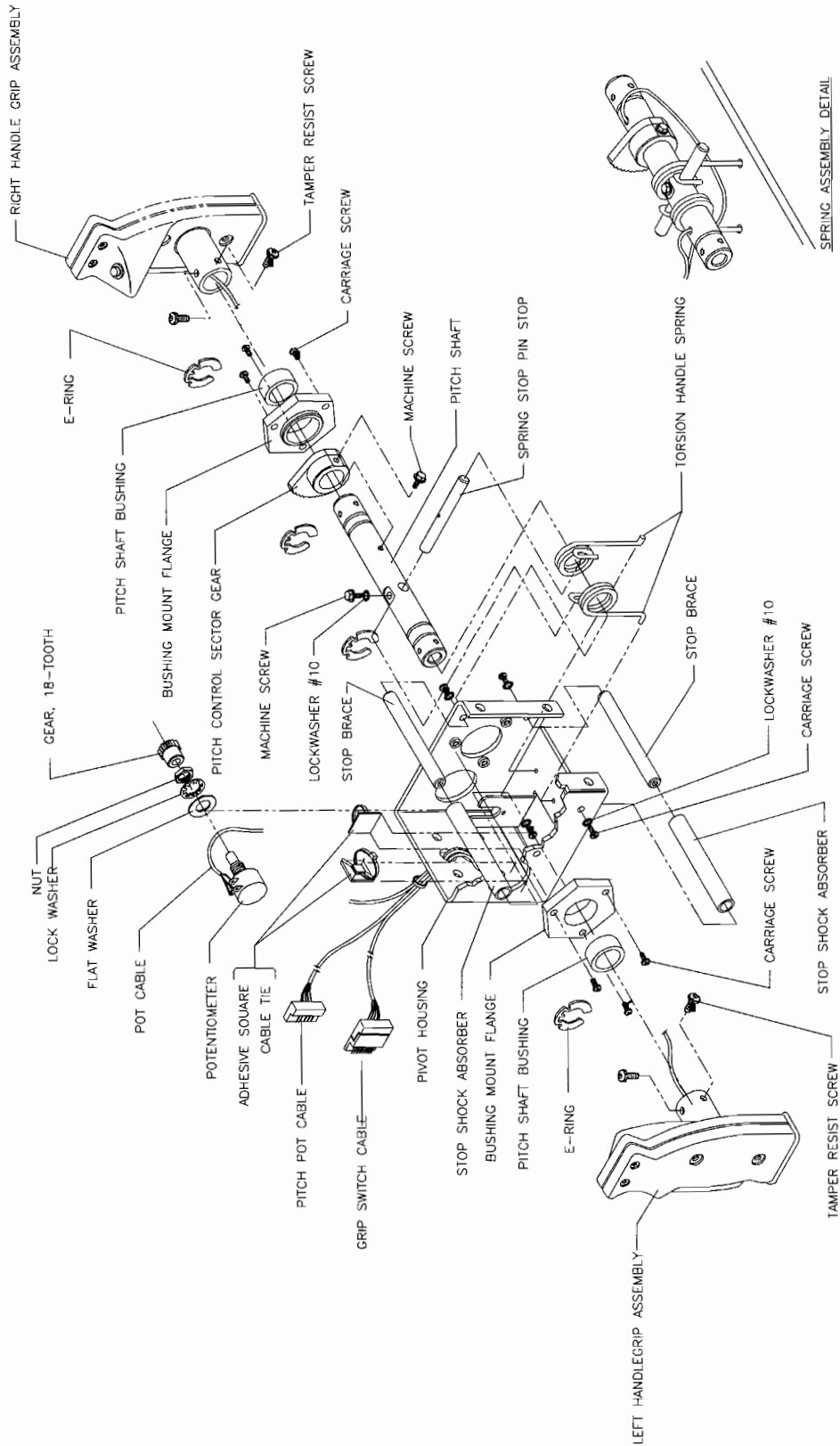

FLIGHT CONTROL ASSEMBLY DIAGRAM

◆ Seat Assembly

Use the T27 tamper-resistant wrench to remove the three screws which connect each side of the lower seat mounting plate to the cabinet. Remove the two hex-head bolts and washers from the upper seat mounting plate. Lift the seat and mounting plate assembly off the main game cabinet. Place the seat on its back, on a flat surface. Remove the six hex-head bolts on the sides of the lower mounting plate to separate the seat from the plate.

IMPORTANT: Apply removable anaerobic adhesive thread lock (Loctite Blue 242 or equivalent) and torque each bolt to seven to nine ft.-lbs (84 to 108 in.-lbs) (0.7 to 1.0 Nm) during re-assembly.

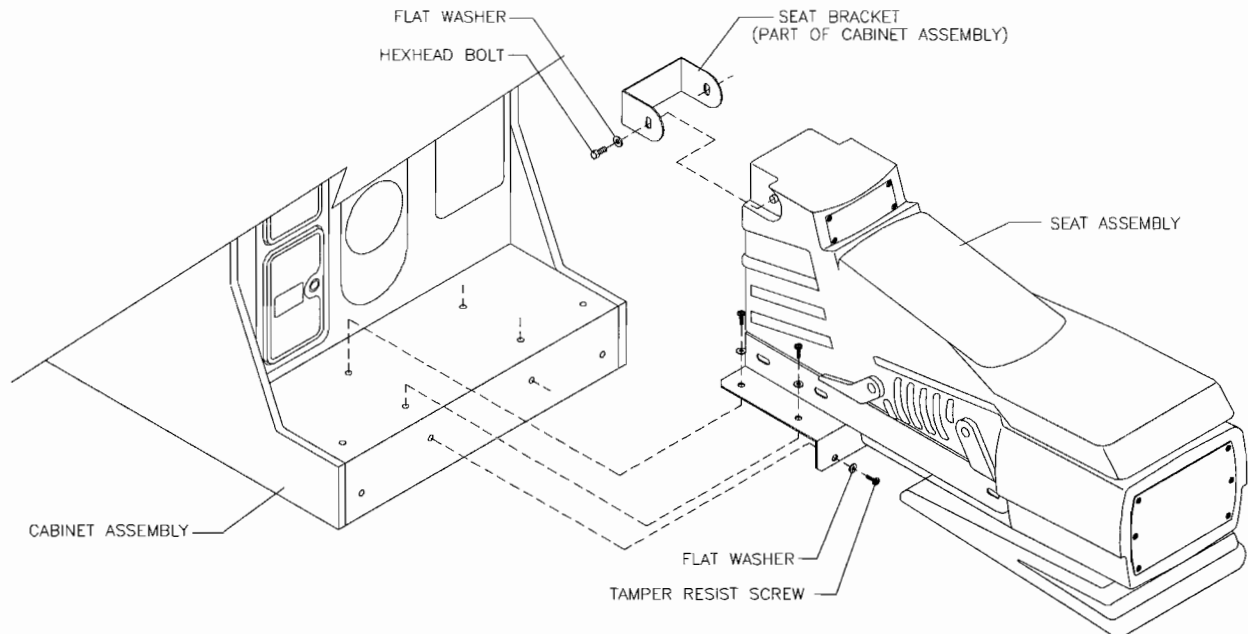

SEAT MOUNTING PROCEDURE

◆ Dashboard Speakers

NOTE: The speakers are magnetically shielded to prevent video monitor color impurity. Be sure that any replacement speakers are also magnetically shielded.

There are two full-range speakers mounted under the grille on each side of the dashboard. Remove the dashboard. Remove the flight control mechanism and the eight nuts holding the dashboard to the dash panel. The speakers come out from the back of the dashboard moulding. Be sure to disconnect the cabling and remove the nuts on the mounting screws before attempting to remove the speakers from the speaker bracket. Carefully reseal the seals upon completing any task in the speaker enclosure. Refer to the Cabinet Wiring Diagram for correct speaker polarity.

◆ Lower Speaker

The lower speaker, an 8" woofer, is mounted in the lower front cabinet panel below the steering mechanism assembly and covered by the front of the seat. Unlock and remove the rear door. Disconnect the cables that go to the electronics rack assembly. Unscrew the rack and set it aside. Reach through the cabinet and disconnect the speaker cables. Remove the mounting screws and pull the speaker out of the cabinet. Carefully reseal the seals when replacing the speaker.

◆ Start/View Buttons

Use the T20 wrench to remove the four tamper-resistant screws from the grille surrounding the button. Pull the plate forward enough to expose the switch. Label and disconnect wires. Separate the switch from its push-button. Bend the large prong away from the switch just enough to slide the switch off the housing. Pull the switch housing from the pushbutton assembly to expose the light bulb. Unscrew the switch mounting nut and pull the entire pushbutton out from the front of the grille.

◆ Coin Meter

Switch off power to the game. Unlock the cash door and swing it open. Remove the cash tubs. The meter is located on a plate at the vault bottom. Remove the screws and lift the plate just enough to disconnect the meter wires from the harness. Record the meter count before testing or replacement.

◆ Coin Mechanism

Switch off power to the game. Unlock the coin door and swing it open. Unlatch and remove each coin mechanism separately to clean or replace with a different type. Ensure that mechanism seats fully in the holder upon reinstallation. Close and lock the release latch, then close the door. Turn on the game and change the mechanism setup, then test known good and bad coins to verify operation.

◆ Transformer

Switch off power to the game and disconnect the line cord. Open the rear door. The Transformer is located under the electronics shelf mounted to the cabinet base. Note the positions of the wires before disconnecting them. Remove the mounting screws and lift the transformer out of the cabinet.

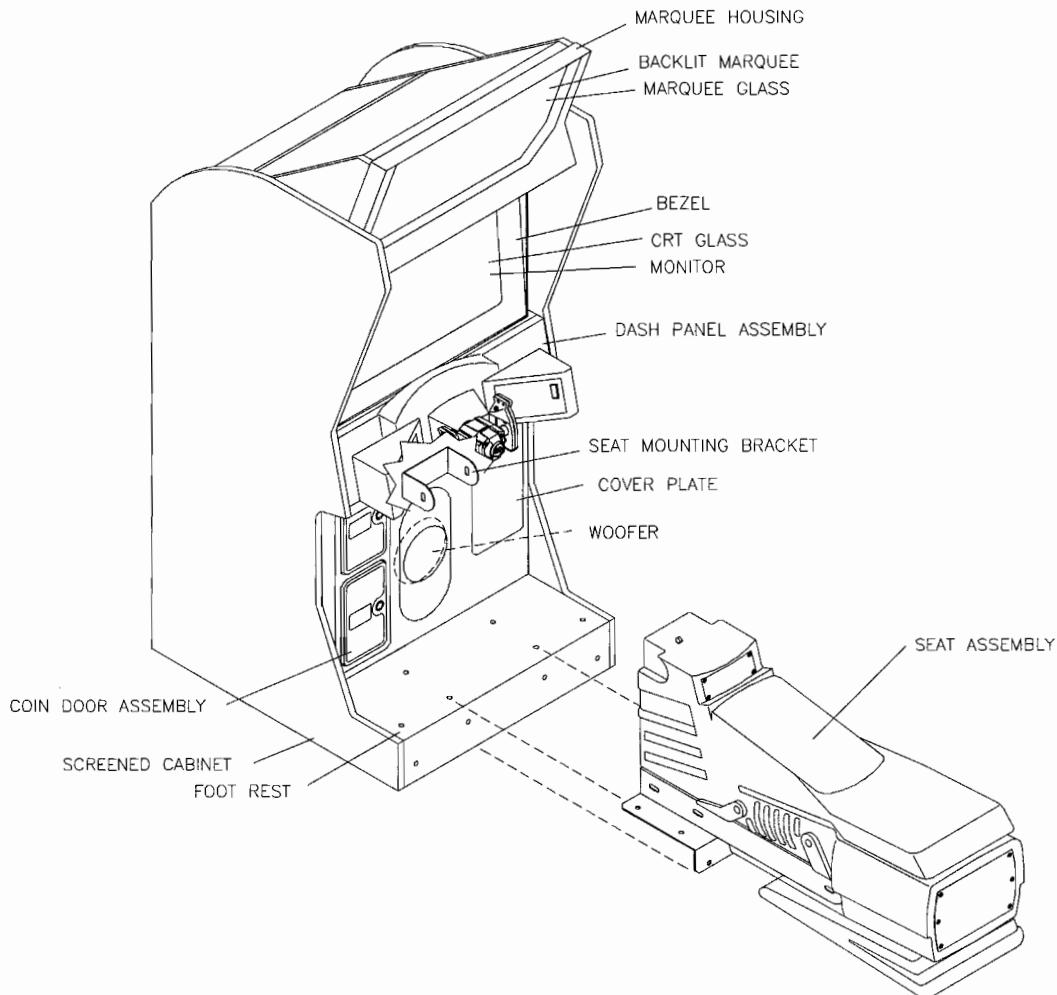

CABINET AND SEAT ASSEMBLY COMPONENTS – FRONT VIEW

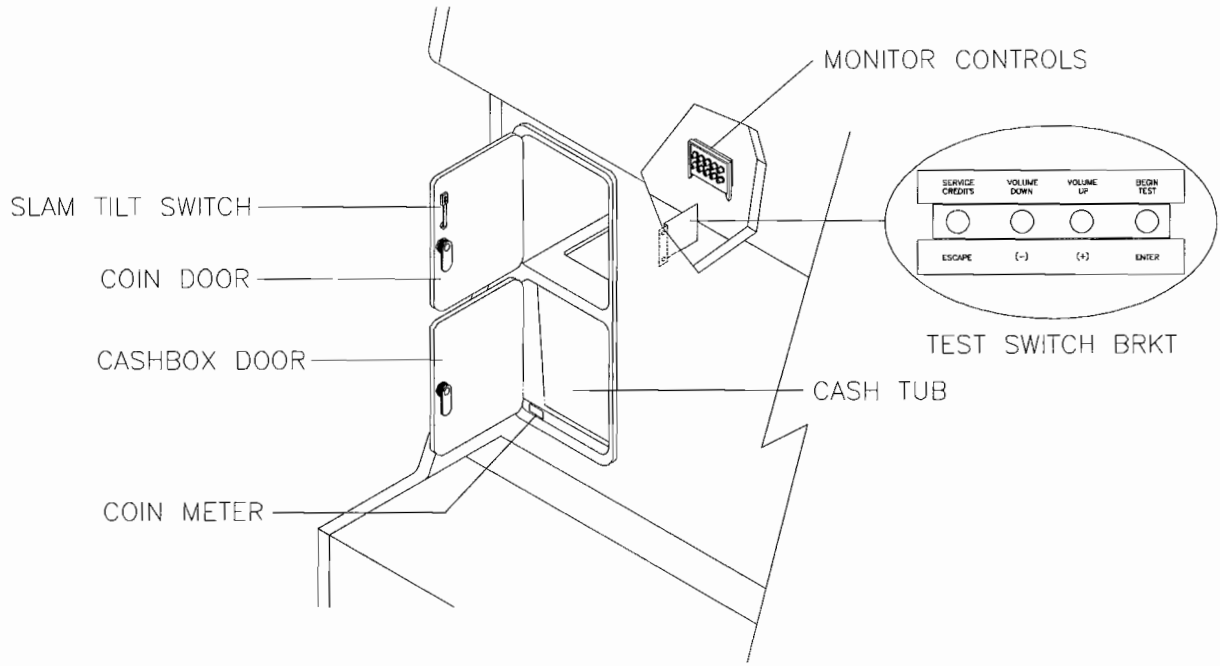

COIN DOOR ASSEMBLY COMPONENTS DETAIL

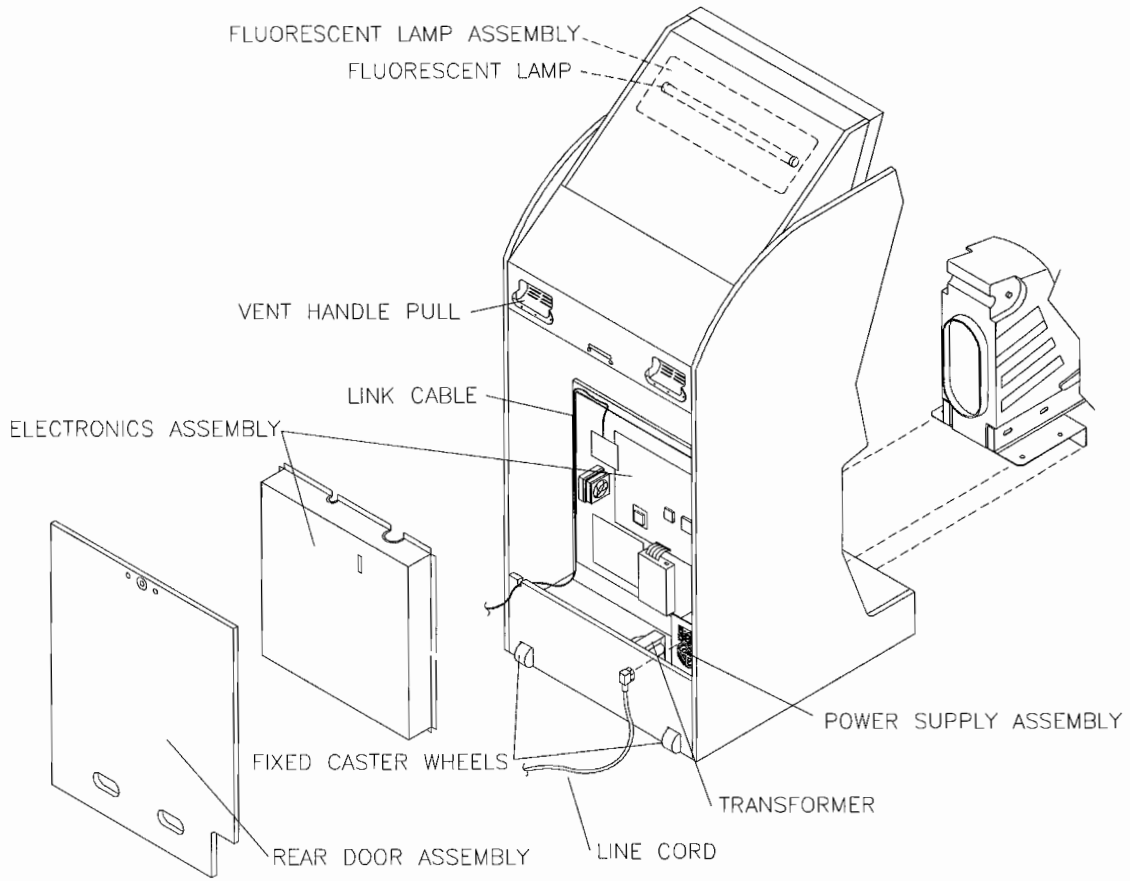

CABINET AND SEAT ASSEMBLY COMPONENTS – REAR VIEW

◆ **Monitor Bezel**

Remove the viewing glass. Grasp the monitor bezel at the bottom and lift it out of the groove. Remove the bezel from the cabinet.

◆ **Monitor**

Read these precautions thoroughly before beginning this procedure.



CAUTION

THE VIDEO MONITOR IS HEAVY, WITH MOST OF THE WEIGHT TOWARD THE FRONT OF THE ASSEMBLY. BE SURE IT IS FIRMLY SUPPORTED AS IT IS REMOVED FROM THE CABINET.

The monitor does not require isolation from the A.C. line voltage in normal operation. However, when operating outside the cabinet or servicing the monitor on a test bench, YOU MUST ISOLATE THE MONITOR FROM LINE VOLTAGE WITH AN ISOLATION TRANSFORMER.

Remove the dashboard, viewing glass, and monitor bezel. Disconnect the monitor from the wiring harness and ground wires. Remove four ¼-20 flange nuts securing the monitor mounting flanges to the mounting panel. Pull the monitor carefully from the cabinet and set aside.

To install a different monitor, remove the three 3/8-16 hex bolts from the bracket at the bottom of the monitor. Install this bracket and its bolts onto the bottom of the new monitor. Slide the bottom of the monitor into the cabinet and tilt it up from the top. Replace the flange nuts at the top of the monitor, and the screws on the outside of the cabinet.

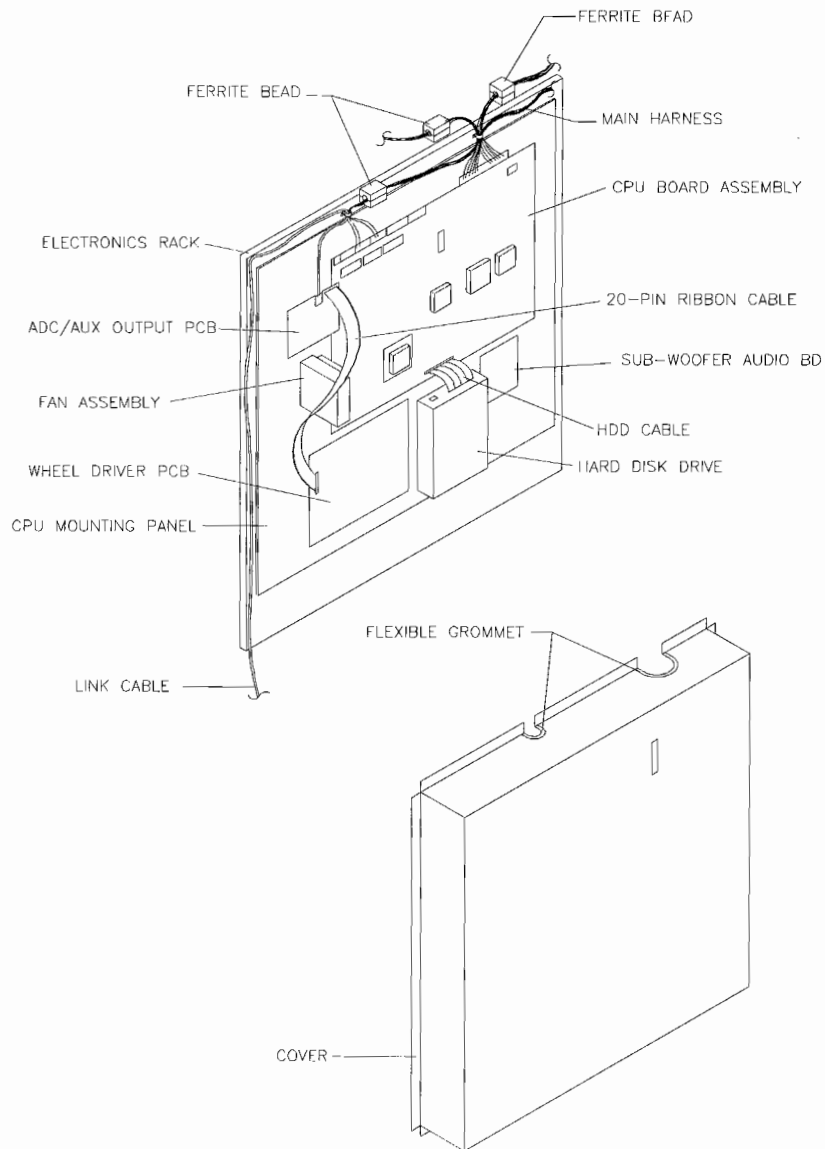

GAME ELECTRONICS COMPONENTS

◆ Power Supply

Switch off power. Remove screws, then unlock and remove the rear door. Unplug the IEC A.C. connector from the rear and the D.C. connector from the top of the supply. Remove two top and two bottom screws holding the supply to the power chassis, then lift it off the power chassis. Note voltage setting.

To reinstall the power supply, remove the voltage switch cover if necessary and set the voltage to the correct value. Set the supply on the power chassis and align the mounting holes. Install the four screws and the two power connectors.

**CAUTION**

THERE IS AN AC POWER DISTRIBUTION BLOCK BEHIND THE POWER SUPPLY. DO NOT TOUCH THE AC TERMINALS WHEN THE POWER SUPPLY IS SWITCHED ON. DISCONNECT THE AC POWER BEFORE WORKING NEAR THE POWER SUPPLY.

◆ Wheel Driver Board Assembly

Switch off power to the game. Unlock and remove the rear door. Carefully note the orientation of the cables. Mark and extract the harnesses and other cables from the board connectors. Remove the four Wheel Board Assembly mounting screws. Lift the board out of the cabinet and set in a safe place.

◆ ADC/AUX Board

Switch off power to the game. Unlock and remove the rear door. Remove the RF Cage top to expose the CPU Board Assembly. Carefully extract and mark each wiring harness or other cable from its connector. Remove the two brass and two silver phillips-head screws holding the board in place and retain them with their washers. Lift the board out of the cabinet and set in a safe place. Place the new board on the mounting posts and refasten with the screws. Reconnect the wiring harnesses and other cables in their proper places.

◆ Subwoofer/Audio Board

Switch off power to the game. Unlock and remove the rear door. Remove the RF Cage top to expose the CPU Board Assembly. Carefully extract and mark each wiring harness or other cable from its connector. Remove the four silver phillips-head screws holding the board in place and retain them with their washers. Lift the board out of the cabinet and set in a safe place. Place the new board on the mounting posts and refasten with the screws. Reconnect the wiring harnesses and other cables in their proper places.

◆ CPU Board Assembly

Switch off power to the game. Unlock and remove the rear door. Remove the RF Cage top to expose the CPU Board Assembly. Remove the ADC/Aux Board by removing the two large and two small phillips-head screws holding the board in place and retain them with their washers. Lift the ADC/AUX board out of the cabinet and set in a safe place. Carefully note the orientation of the JAMMA connector and the other cables. Extract and mark the harnesses and other cables from the board connectors. Remove the ten CPU Board Assembly mounting screws. Lift the board out of the cabinet and set in a safe place. Anti-static bags and protective containers from new parts may be used for storage if not to be reinstalled immediately. Be certain to reinstall the RF Cage top so that it seals tightly against the RF Cage bottom.

◆ Memory Replacement

The ROM (Read Only Memory) circuits contain the computer operating instructions. *Memory devices are especially sensitive to static charges. Use grounding precautions when handling these parts.*

Switch off power to the game. Unlock and remove the rear door. Remove the RF Cage top to expose the CPU Board Assembly. Carefully note each IC position, then remove them using a chip extraction tool.

To reinstall memory circuits, orient a chip over its socket and press firmly to seat pins. *Do not force.*



CAUTION *Discharge any static electricity build up in your body by touching the power supply chassis. Do this BEFORE touching or handling the electronic assemblies.*

◆ Battery

Switch off power to the game. Carefully note the battery position, then gently lift the contact arm to release tension. *Do not bend the arm.* Slight finger pressure may be needed to pry the cell from its holder. *Avoid direct shorts across terminals or from terminals to ground.*

To reinstall the battery, orient it near its holder and slide it in under the contact arm. *Do not force.*

! **CAUTION** *Danger of explosion if battery is incorrectly installed. Replace only with the same or equivalent type recommended by the manufacturer. Dispose of used batteries according to instructions printed on the battery or the manufacturer's packaging.*

◆ Dollar Bill Validator

(Use MARS AE2411-U3 U.L. Recognized currency changer)

Dollar bill validators or other currency acceptors may be installed in games that were manufactured with the additional wiring connector. Switch off power to the game and unplug the A.C. line cord. Unlock the coin door and swing it open. Read door label for additional information. Disassemble the validator and remove material to permit it to fit inside the coin door as illustrated, then reassemble unit.

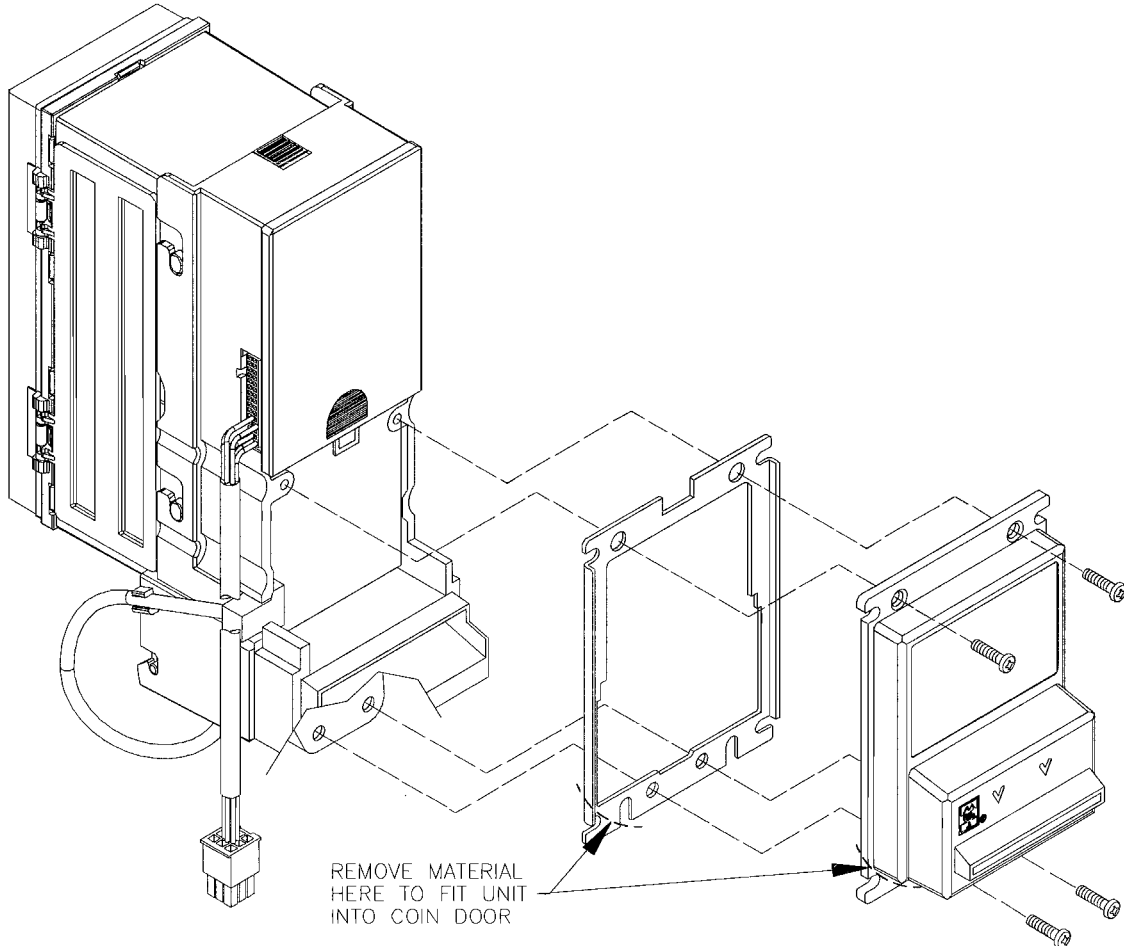

Remove nuts, spacers, and cover plate from the door. Change switch settings or make adjustments before mounting the unit. If the manufacturer has supplied an adapter plate, place it over the door cutout at this time. Install spacers on threaded studs, then align the validator mounting holes with the studs and seat the unit in the door opening. Install the nuts and tighten firmly. Attach the ground

wire (green with yellow stripe) lug to the door ground stud next to the hinge. Mate the wiring harnesses and press to fully seat connectors. Route wires away from door edges and hinge. Inspect for proper bill chute alignment. Plug in the line cord and turn on the game. Change the mechanism setup and pricing, then test known good and bad bills to verify proper operation. Close and lock the coin door when correct. Reverse these steps to remove a validator for service or replacement.

GAME OPERATION

Initial Start Up

When the game is first turned on, power is restored, or a reset occurs, it executes the boot ROM code. Automatic self-diagnostic tests verify and report the condition of the hardware, memory, hard disk drive, etc. If any of the individual tests fails, then an error message displays for that particular test. Record all messages before starting a game. The message will be displayed until the ABORT button is pressed.

- ◆ If no buttons are pressed, the system will quickly complete all tests then load and run the game.
- ◆ Press and hold the coin door TEST button to skip the boot ROM tests and activate the Menu System.

Once Power-up tests have been completed, the game goes into ATTRACT MODE. Scenes and sounds from a typical game are alternated with previous track times in endless repetition until game play starts.

Attract Mode

Before the game starts, the ATTRACT screens show scenes and sounds from typical races on each of the tracks. Alternating with these scenes are views of the cars, best track times, game production team acknowledgements, etc. The attraction screens cycle endlessly until a player or operator starts the game.

The operator can choose to add more ATTRACT screens to the standard presentation, if desired.

Test Mode

The operator may enter the menu system at any time to analyze the game or adjust it if required.

NOTE: Do not enter the Test Mode with other linked games in progress. This may halt games.

GAME RULES

Individual Play (Stand Alone Operation)

Choose any cabinet. Insert currency to start the game. The player must choose the following variables:

1. The player selects a track. Each track has a different skill level and quantity of checkpoints. The XTREME track is not available unless one player has successfully completed the other three tracks.
2. The player selects a vehicle. Each vehicle has different handling capabilities.

Head to Head Play (Linked Operation)

Choose a linked cabinet (on-screen messages and optional overhead signs identify the linked games). Insert currency at the RACE IS ABOUT TO START JOIN IN NOW message. There are now some restricted choices:

1. Any player indicates linking is desired. That player selects a track. All tracks are available as before, but the first player to make a selection determines the track for the other competitors. Others are invited to participate at the RACE IS ABOUT TO START JOIN IN NOW message.
2. At least one other player must respond to the RACE IS ABOUT TO START JOIN IN NOW screen message.
3. The players select vehicles and may choose identical ones if desired.
4. The LINKED GAME message displays until it times out or until other players begin making their selections.
5. After the round of head-to-head play is finished, players can join in again for the next race or can decline linked racing and revert to individual play.

NOTE: Players may decline a linked race by waiting for the JOIN IN message to time out. If no other players accept a linked race, the games revert to individual play.

GAME PLAY

1. Any vehicle can be used on any track. Each vehicle handles and performs differently. Players will learn which vehicles are best for a given track and driving style.
2. On-screen indicators give the players information about their competitors. Across the top of the screen are indicators for race position, elapsed time, and time remaining to pass the next checkpoint. A scanner display shows the relative track position of all vehicles during game play. Gauges show vehicle speed, "turbo" status, and weapons available.
3. There are many secret features built into the game. Most tracks have shortcuts. Players are encouraged to find other secret features by experimentation.

GAME FEATURES

VAPOR TRX is shipped configured as a one-player game. Up to eight cabinets may be linked to permit player competition.

Starting Up

Switch ON power to the game. The game begins internal tests (display messages about the software version and hardware test results). If there are no errors the game enters ATTRACT mode automatically.

A machine status screen will appear for about ten seconds. This is a game network activity report. The screen is used to verify and troubleshoot connections between cabinets when they are linked.

NOTE: When the internal tests detect an error, the game halts and an error message appears on the screen. Record any messages before attempting to service the game.

To calibrate player controls, enter the menu system and select CONTROLS TEST, then follow the on-screen instructions. Refer to CONTROLS TEST later in this section for more detailed information.

Before the game starts, the ATTRACT screens endlessly cycle through scenes and sounds from typical races on each of the tracks. Insert the desired amount of coins or tokens and press start to begin.

Preview

In the ATTRACT mode, the game automatically cycles through scenes and sounds from typical races on each of the tracks. The ATTRACT mode presents players with continuous lap after lap views from several different camera angles and driver perspectives. Use this feature to see some of the fast grooves for the different tracks.

This preview feature demonstrates each of the tracks in the game. This allows players to decide which track is best suited to their needs when considering head-to-head competition.

Tracks

The first player selection screen permits course choices. Each track requires a different skill level. More challenging tracks decrease the time between checkpoints and increase course difficulty. This forces players to maintain higher speeds and allows fewer errors in judgement to continue racing. The "Xtreme" track normally is not available until a player successfully completes the other three tracks, unless the "Tracks to Complete Before Bonus Track" setting in Game Options is "none."

If games have been connected together in a network, players will choose to accept or decline a race against other players from this screen. A LINKING message is illuminated when this type of competition is possible, and a JOIN IN message alerts other players when they get to the track selection screen.

In linked play, the first player to choose a track determines the course for all linked players. Certain tracks allow players to take shortcuts to catch up to or pass other players. In linked races, at least one player must complete the checkpoints in the time allowed for the race to continue.

Vehicles

Players may choose from vehicles in any position by rotating the steering mechanism until the desired vehicle is highlighted and pressing START to select it. Each vehicle has particular characteristics that may be advantageous depending on the track selected. All vehicles benefit from passing through green TURBO markers along the track. Players lose some TURBO power when they crash.

Race Length

Several things affect the length of a race. Difficult tracks have more turns and require speed changes between the start and finish lines. Players must reach each checkpoint before time expires to continue racing. Players receive bonus time when they pass each checkpoint.

Missiles

Players can collect one or more missiles by flying through missile indicators along the course. Firing missiles successfully at an opponent advances the player one place ahead in the race. Collecting cannon markers increases the power and accuracy of a player's weapons.

Obstacles/Shortcuts

There are various obstacles along each course. Players must avoid these obstacles to finish the course quickly. Hidden shortcuts along each course allow players to catch up to or pass competitors.

PLAYER CONTROLS

The player controls are used to guide the vehicle and select a view of the course.

◆ Throttle Switches

The throttle switches are on the screen side of each steering mechanism handle. During game play, the throttles control acceleration. Squeeze the throttles to increase acceleration during play. Release the throttles to activate the air brakes.

◆ Thumb Buttons

The thumb buttons are on the top of each steering mechanism handle. The thumb buttons control the release of missiles during game play. Press the thumb button to release a missile after aiming at a target.

◆ Start/View Button

The start/view button starts game play selections, chooses game track and vehicles, and controls the player's track perspective during game play. Press this button during play to change the player's viewing position for optimum player performance.

◆ Flight Control Mechanism

The flight control mechanism is used to aim the vehicle during a race. It provides track feedback to players. Turning the handles to the left or right moves the vehicle in the same direction. Twisting the handles forward or back moves the vehicle up or down.

Note: Operators can adjust the steering wheel force and feedback to suit any player's driving styles. Refer to GAME OPTIONS and CONTROLS TEST in the SELF TEST menu system for instructions.

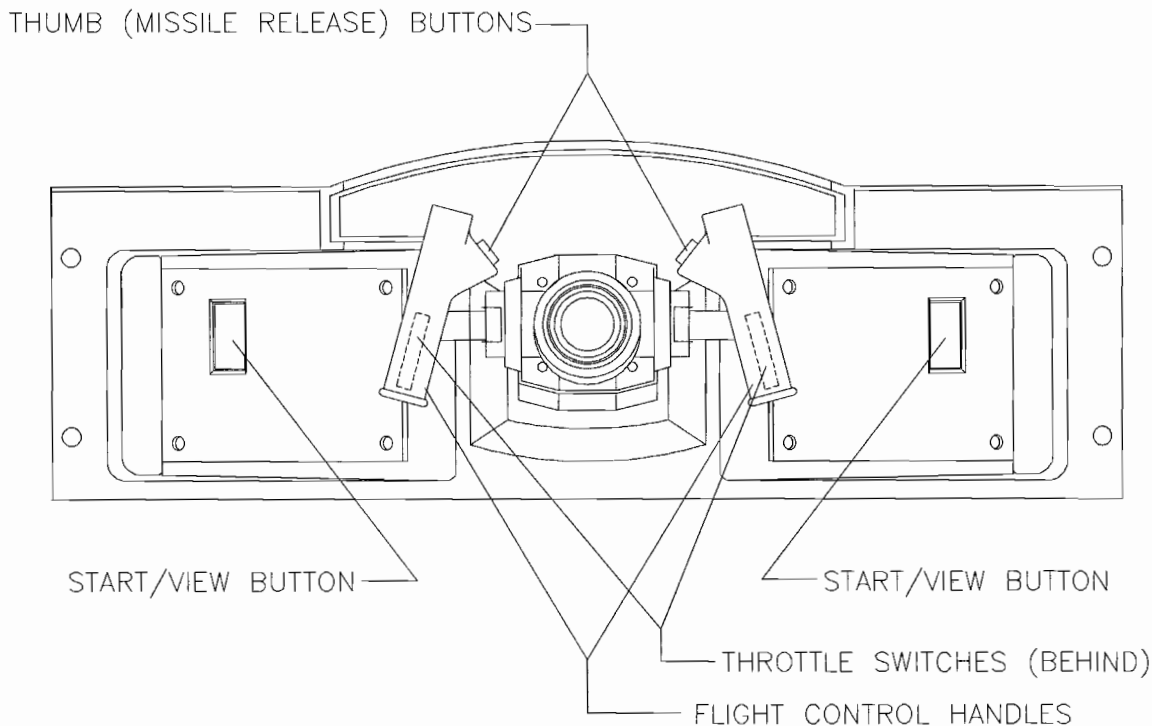

PLAYER CONTROL LOCATIONS

OPERATOR CONTROLS

Operators have lock-and-key access to the menu system for statistics, adjustments, and testing to prevent tampering. On-screen messages guide the operator through menu options.

Cabinet Switches

- ◆ The **ON/OFF SWITCH** is located on the power supply body, near the bottom right of the cabinet (when viewed from the rear).
- ◆ The **MONITOR REMOTE ADJUSTMENTS** are located inside the coin vault. Use the monitor test screens with these controls to adjust the video image size, brightness, contrast, etc.
- ◆ The **SLAM TILT SWITCH** detects any forceful vibrations against the coin door. This eliminates pounding for free games. It is located on the inside of the coin door opening near the lock.

NOTE: There is no **SLAM TILT SWITCH** on **DBV ready coin doors**.

Control Buttons

- ◆ The **TEST BUTTON** activates the game SELF TEST menu system. Press the Test button to access the Main Menu and select individual diagnostics, audits, utilities, and other features.
- ◆ The **VOLUME UP BUTTON** moves up through the menu selections or adjustment items and raises the sound level in game play. The **Right Thumb** button also moves up through selections.
- ◆ The **VOLUME DOWN BUTTON** moves down through the menu selections or adjustment items or lowers the sound level in game play. The **Left Thumb** or **Right Throttle** buttons also move down through selections.
- ◆ The **SERVICE CREDIT BUTTON** allots credits without affecting the game's bookkeeping total. Press this button to get out of a menu selection or return to the main menu.

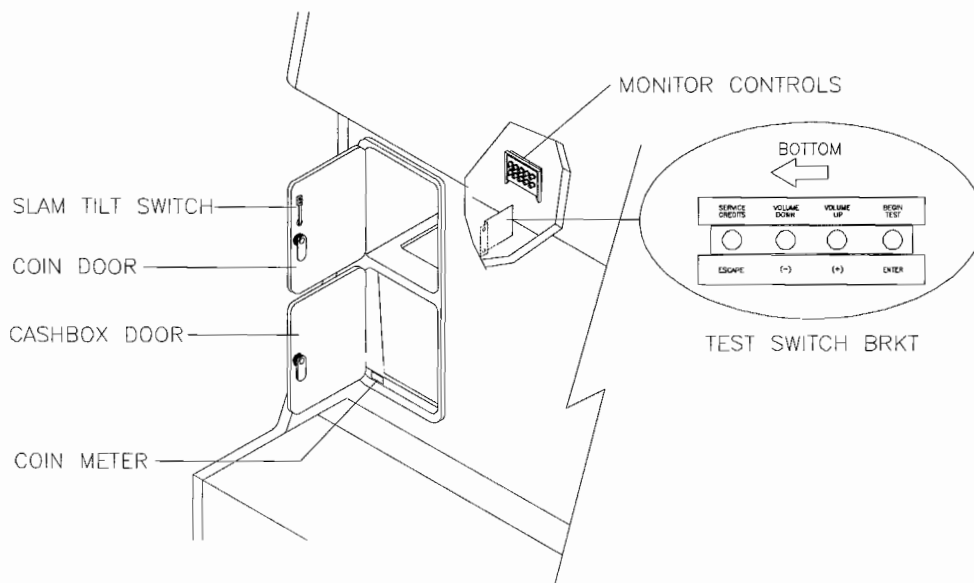

OPERATOR CONTROL LOCATIONS

POWER ON TESTS

The Power On Tests conduct internal checks to determine if individual components are operating properly. This routine occurs whenever the game is switched on or a press of the button on the circuit board resets the CPU. Once the hardware tests are successful, the CPU loads the software from the hard disk drive. A series of messages display briefly before the attract screen sequence begins.

Turning on the power or resetting the circuit board does NOT recalibrate the player controls. Refer to CONTROLS TEST for instructions on how to calibrate player controls.

Manual testing more thoroughly diagnoses errors (refer to CONTROLS TEST in this section).

A successful self-test takes less than one minute to complete. Write down any error messages before proceeding to menus or game play. Consult Troubleshooting (Section Four) for assistance with errors.

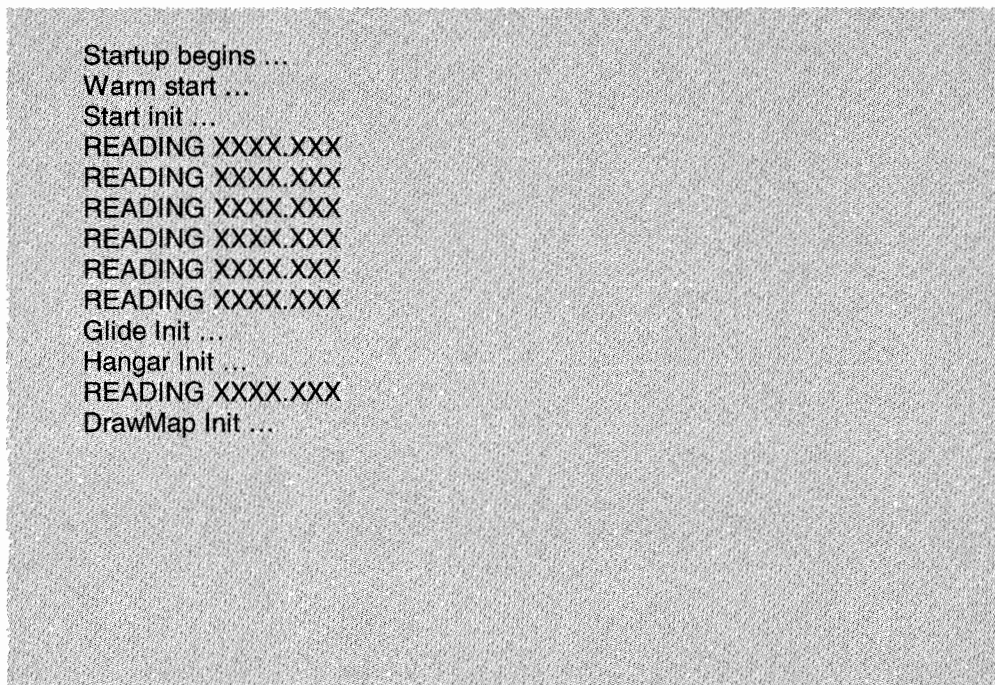

TYPICAL POWER ON TEST SCREEN

SELF TEST MENU SYSTEM

System Overview

A series of on-screen menus presents game variables and diagnostics. The Main Menu screen allows the operator to view information, make changes, or verify equipment operation. Each Sub Menu screen displays one specific group of choices. The Detail Menu presents data or runs the required test. You must be at the Detail Menu level to detect errors, make changes, or activate tests. Use either the operator controls or the player controls to move through the menus and start or stop particular routines. Press and hold the TEST coin door button until the SELF TEST main menu appears on screen.

Screen Layout

Each menu screen is different, but the material presented stays in the same order each time.

*The color bar at the top center of each screen displays the current menu title.

*The center of the screen displays data (menu items, video signals, statistics, reports, etc.).

*The bottom of the screen displays messages (control functions, revision levels, etc.).

Organization

Main Menu screen items fall into two categories: options and tests. Activate each item manually.

Sub Menu screen items offer the operator choices within a category. Some items have no Sub Menu while others may have more than one. You can get back to the previous menu or go on to the next menu.

Detail Menu screen items contain specific information. The operator must interact with the system to get results or to make changes. There is always a way to go back to the previous menus from this screen.

Use the control indicated to highlight an item on any menu. *Only one highlighted item can be selected at a time.* To return the game to normal, select EXIT TO GAME, then press the indicated button.

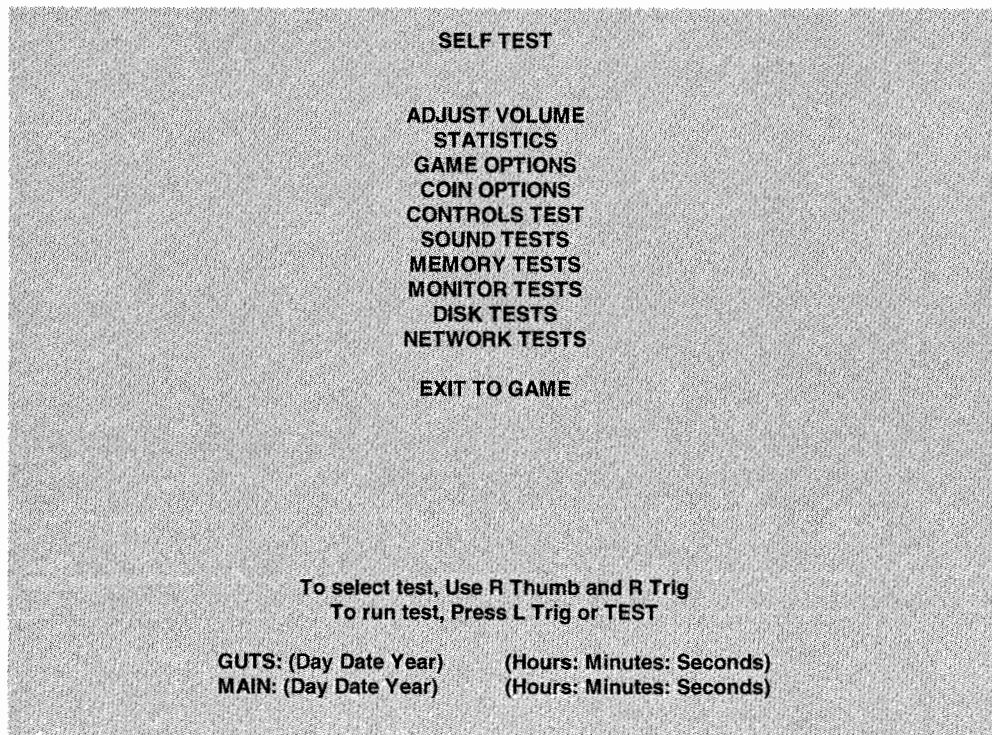

TYPICAL SELF TEST MENU SCREEN

Adjust Volume

The ADJUST VOLUME feature allows the operator to set the sound and music levels of the game.

The volume level can be adjusted separately for either the Attract or Game Mode. Press the Left Throttle button to select Game Volume or Attract Volume. Press the VOLUME DOWN button to lower the volume level or the VOLUME UP button to raise the volume level. Music plays continuously while this screen is active.

NOTE: Open the coin door and use the VOLUME UP and VOLUME DOWN buttons to adjust the volume levels without going through the menu system during a game or when in attract mode.

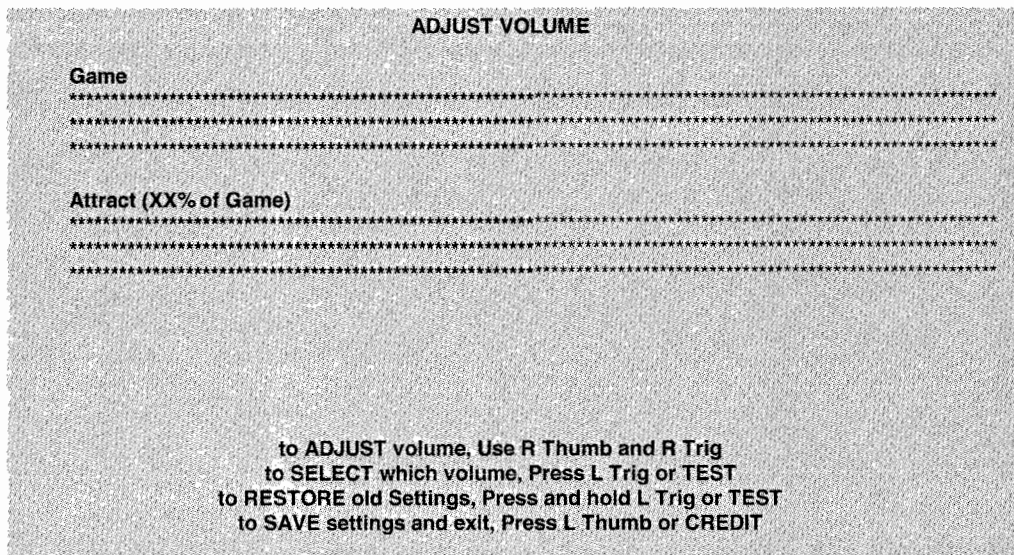

ADJUST VOLUME MENU SCREEN

The “Game” volume ranges from zero to maximum. The game will seem more realistic if the player experiences high volume sounds during play.

The “Attract” volume ranges from zero to maximum. For greater profits, adjust your volume levels to a loud setting to draw attention to this game.

The length of a bar made of asterisks represents the current volume level. A longer bar indicates a higher volume setting than a short bar.

The “Attract” and “Game” volume levels may be adjusted to different values, but the “Attract” level cannot be set higher than the level chosen for normal game play. If the “Game” level is lowered, it will automatically lower the “Attract” level. Lowering the “Attract” level will not effect the “Game” volume.

NOTE: These adjustments affect the volume both of the tests and the game play. If the volume levels are set to minimum (zero), there will be no sounds from the speakers during any of the audio tests. Set the volume levels to a moderately high value each time the sound portion of the game is checked. After completing the tests, return the levels to their previous settings.

Statistics

The STATISTICS report allows the operator to assess player skill level and game earnings. In addition to the earnings, STATISTICS tracks various game aspects to determine the players' skill level.

STATISTICS may be reset to zero or allowed to increase after each viewing. To reset statistics, hold the START or TEST button, then press the SERVICE CREDIT button. Press the Left Thumb button to see more statistics.

| STATISTICS | |
|--|--------|
| Left Coins | :0 |
| Right Coins | :0 |
| Aux Coins | :0 |
| Idle Minutes | :0 |
| Play Minutes | :0 |
| New Games | :0 |
| Cont. Games | :0 |
| Free Games | :0 |
| Total Games | :0 |
| 1-Player Games | :0 |
| 2-Player Games | :0 |
| BRAM Read Errors | :0 |
| | |
| Total Coins | : 0 |
| AVG TIME/COIN | : 0:00 |
| Percentage Play | : 0 |
| Free Game Percent | : 00% |
| | |
| To clear these counters, Hold TEST or L Trig and Press L Thumb or CREDIT For more stats, Press L Thumb or CREDIT | |

STATISTICS REPORT MENU SCREEN

The illustration shows how the report screen looks after the game has been reset or is first turned on. Most of the statistics will increase as the game is played. It is normal for some values to remain at zero: for example, the Coins count will not change if the cabinet has been set up for free games, and the Error count will not change if no errors have occurred.

Low counts in both coin and player statistics may indicate that the game is too difficult for the skill levels of the players at the game location. High counts may result if Bonus or Winner option menu items are in activated. Adjust the difficulty level and other play characteristics from the Game Options menu.

Record the Statistics before doing any service or repairs on the game.

Press the Left Thumb button to view additional game statistics displayed in the form of Histograms. If a game has not been played before, or if the counters have been cleared, there will be no additional statistics.

HISTOGRAMS allow graphical analysis of statistics. This permits visual comparisons between games. The HISTOGRAMS screens will have no bar graphs until the system has enough data. Press the Left Thumb button during the STATISTICS display to show a list of HISTOGRAMS.

A USER MESSAGES screen may appear if the game has stored error codes or other useful information. As with Statistics, record these messages before doing any service or repairs on the game.

Game Options

These adjustments allow the operator to customize the game. Each of the variables will change some aspect of game appearance or play. Optimum settings cause high player interest and increase earnings.

Use the Right Throttle button to select a particular menu item. The START button changes variables. Options may be reset to factory default values or changed after each viewing.

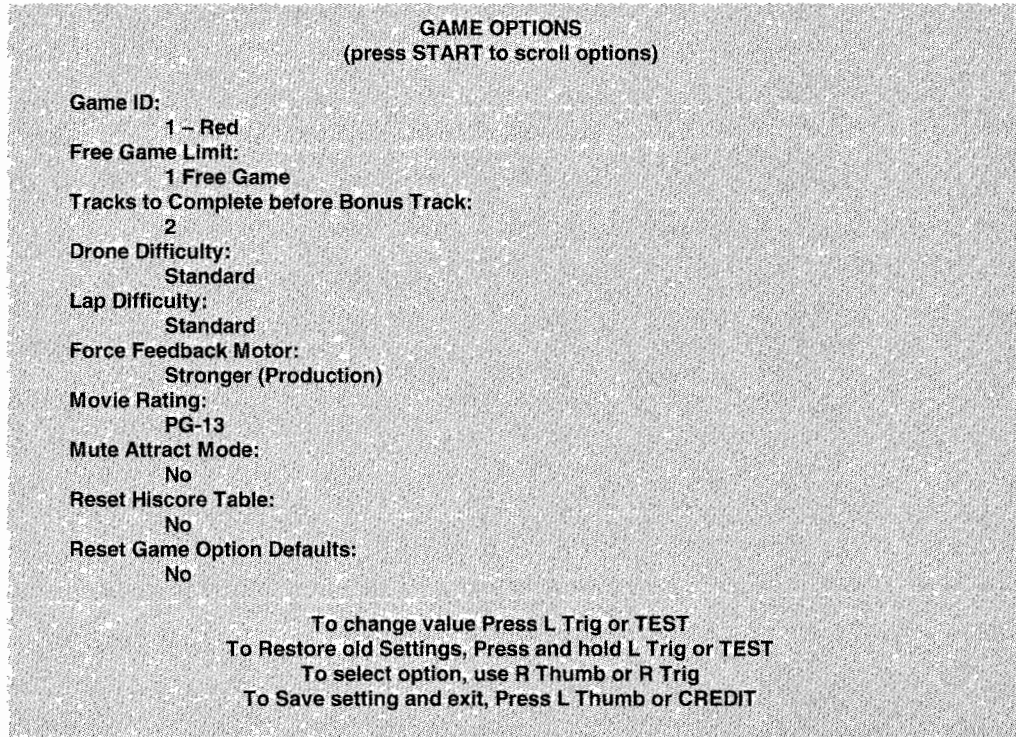

GAME OPTIONS MENU SCREEN

The illustration shows how this screen will look with all of the factory default settings. Each press of the Left Throttle button advances a variable through its range of choices. Some items have more options than others do. Examine all choices before selecting one.

Comparing statistics reports before and after making changes to options reveals their effect on game play. As players become more familiar with the game, you can add new features or increase difficulty.

Coin Options

The COIN OPTIONS set up the coin mechanisms and set the pricing of the games. Factory default values can be considered standard.

Use the Right Throttle button to select a particular menu item. Use the START button to change variables. Options may be set to factory default values or changed after each viewing.

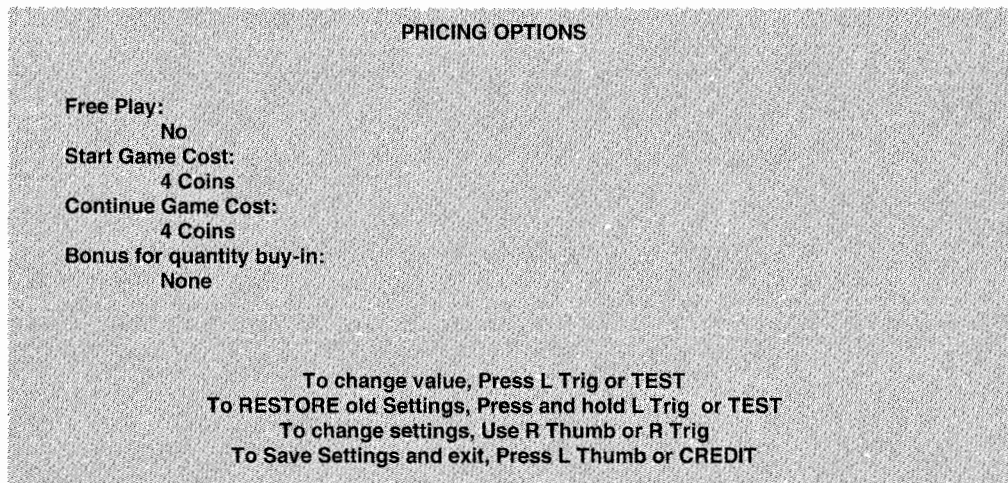

PRICING OPTIONS MENU SCREEN

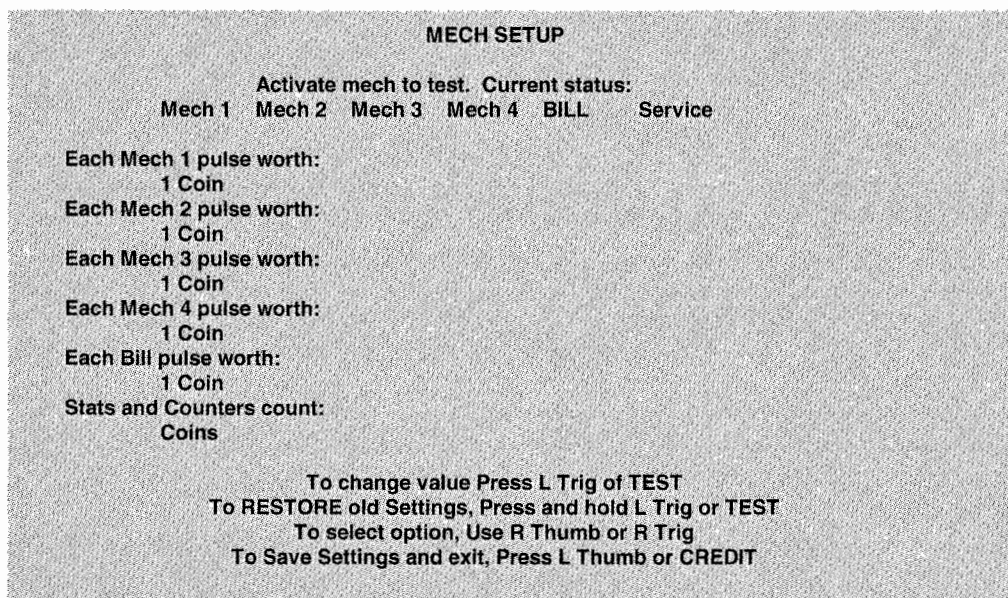

MECH SETUP MENU SCREEN

The illustrations show how these screens will look with all of the factory default settings. Some items have more options than others do. Press the Left Throttle button repeatedly to view all options before selecting one.

PRICING OPTIONS

This sets the number of credits required to start and continue a game and rewards for buy-in. Free play eliminates all other pricing options. Free game player incentives may reduce earnings.

MECH SETUP

MECH SETUP permits the operator to add, remove, or test coin or bill mechanisms. Although values are shown for all devices, changes to unused inputs have no effect if no such mechanism is installed.

Controls Test

These tests allow the operator to check each switch in the game and to calibrate certain player controls.

NOTE

Some switches may not be used with this game. Check the wiring diagram and the mech setup items.

As switches are activated, the screen indicator changes. Releasing the switch returns the indicator to its previous condition. Switches may be tested in any combination. Press and hold the Left Thumb button to end the tests.

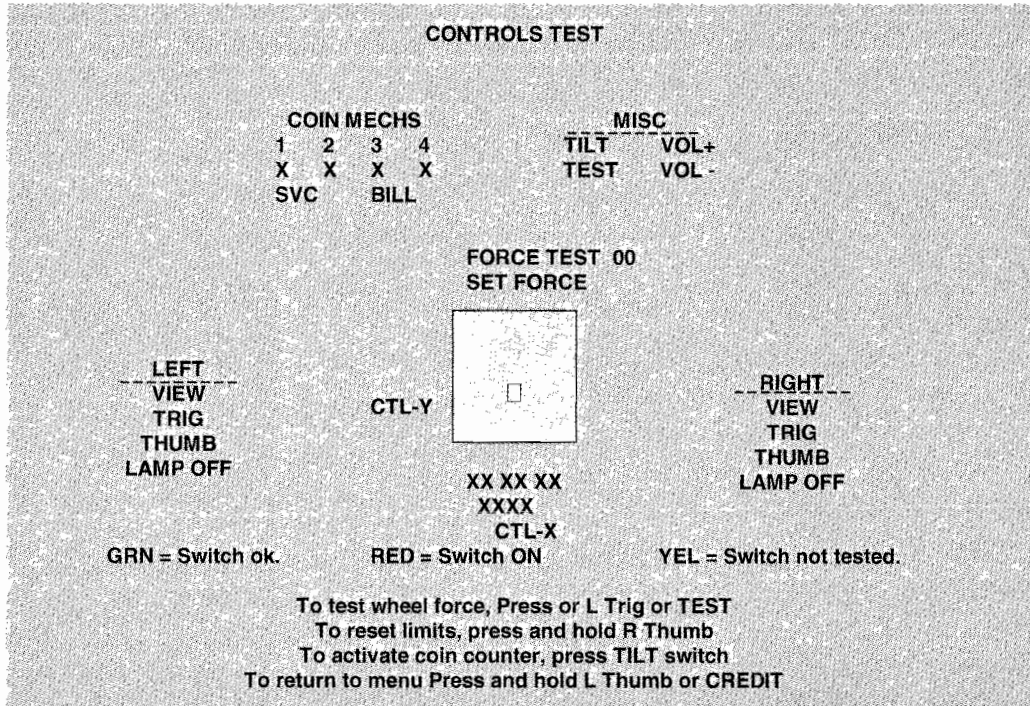

CONTROLS TEST MENU SCREEN

The Controls on the screen appear as they are found on the dashboard, steering mechanism, and in the coin door area. Each control change should be duplicated exactly by a single indication on the menu screen.

The Controls Test screen is used to verify crossed wires, intermittent conditions, and stuck switches.

Press and hold the Left Throttle button to test the Steering Wheel force. Restrain the wheel with one hand during the test. The force will increase to maximum and decrease to minimum, then change directions and repeat again until the Left Throttle button is released. Use this test to check for looseness, binding, belt slipping, motor power, etc.

Press and hold the Right Thumb button to reset the steering mechanism limits. The CTL-Y and CTL-X values should change from green to red. Turn the steering mechanism fully left, right, and forward. The values should change back to green.

Note and record the Coin Counter reading before beginning the test to avoid subsequent count errors. Press the Coin Door Slam Switch to increase the count by one digit. *Do not bend Slam Switch contacts.*

Sound Tests

These tests verify the proper connection and operation of the audio components.

NOTE: *Increase the VOLUME to a moderately high level to test the speakers accurately.*

There are no custom settings or adjustable variables in these tests. The test is performed automatically.

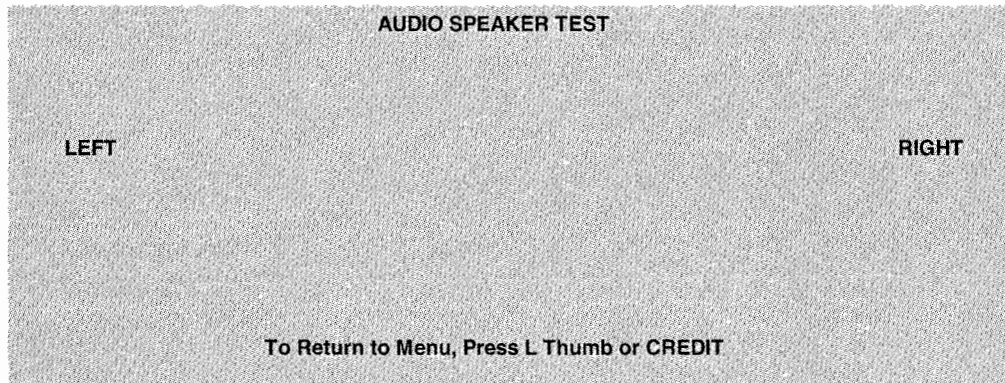

SPEAKER TEST MENU SCREEN

AUDIO SPEAKER TEST sends alternating voice sounds to the left and right speakers. The voices should be clear and distinct from each other. Each voice must come from the location identified. Refer to ADJUST VOLUME screen if necessary to increase loudness for this test.

The Audio Speaker Test screen verifies crossed connections, incorrect phase, and distortion. Press the left thumb button to end the Audio Speaker Test and return to the SOUND TESTS menu.

AUDIO BOOMBOOM (WOOFER) SPEAKER TEST sends alternating high and low pitch sounds to the speakers. This test helps to verify operation of the woofer, located in the front cabinet panel under the upper seat bracket.

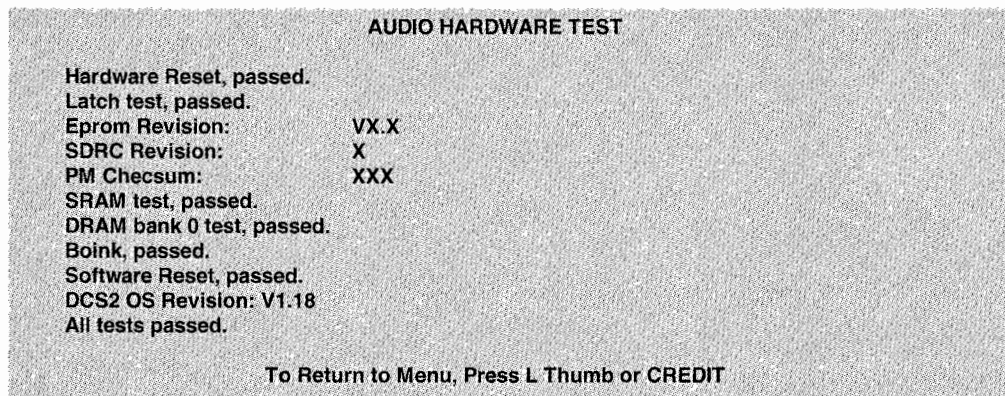

AUDIO HARDWARE TEST REPORT SCREEN

AUDIO HARDWARE TEST automatically tests the electronic components of the audio amplifier for problems and reports the results as “passed” or “failed.” Each “failed” result should be noted and referred to qualified service personnel. This test also shows the revision numbers for the audio EPROMs and other components. Press SERVICE CREDIT to return to the SOUND TESTS menu after noting and recording any errors.

NOTE: If any test reports a “failed” result, refer to Troubleshooting in Section Four.

Memory Tests

The MEMORY TESTS are used to verify some functions of the CPU Board Assembly memory circuits.

NOTE: *These tests detect system errors, not game errors. The game program is on the Hard Disk Drive.*

Press the TEST button to select a particular menu item. Press the Left Throttle button to begin the tests and Left Thumb button to abort them. There are no custom settings or adjustable variables in these tests.

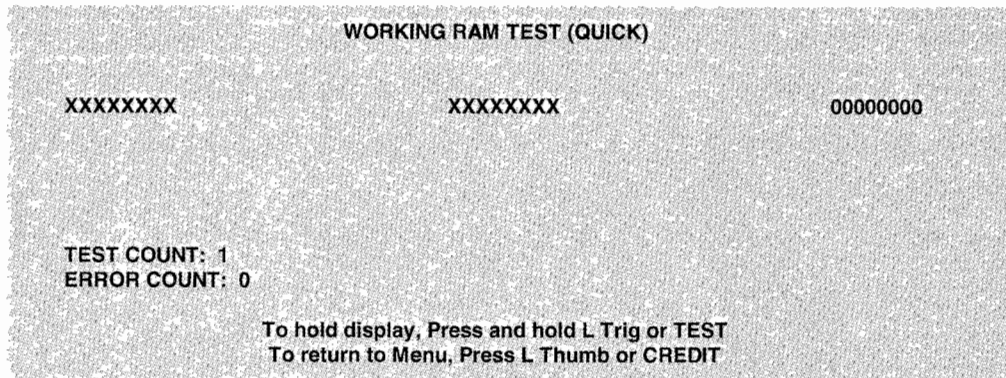

QUICK RAM TEST MENU SCREEN

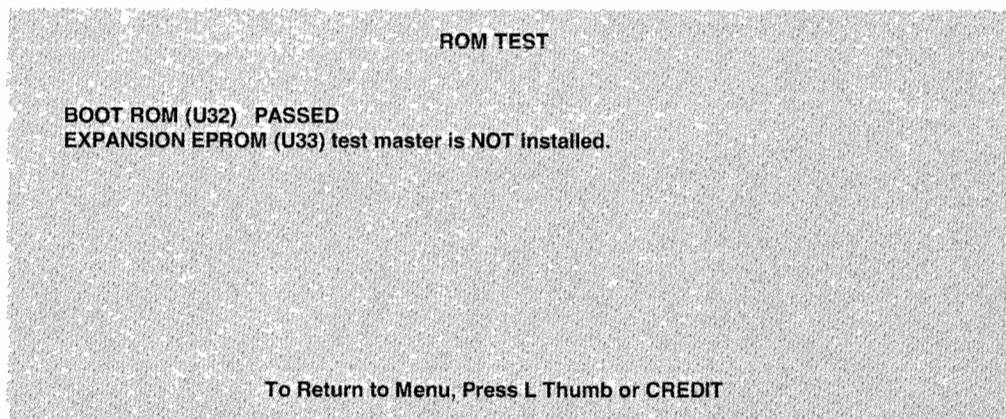

ROM TEST MENU SCREEN

WORKING RAM (QUICK) performs a fast verification of the storage area for the game variables. This test takes less than 10 seconds to run. After completion, the display returns to the Memory Tests screen. The results of the test will be reported as pass or fail messages; there may be error messages.

WORKING RAM (FULL) performs a more thorough check of the storage area for the game variables. This test takes less than 45 seconds to run. After completion, the display returns to the Memory Tests screen. The results of the test will be reported as pass or fail messages; there may be error messages.

ROM TEST performs a fast check of the storage area for the game instruction set. This test takes less than 2 seconds to run. At completion, press the Left Thumb button to return to the previous menu. The results of the test will be reported as pass or fail messages; there may be error messages.

NOTE: These memory areas store data for game play and video display. Audio memory tests are separate (refer to the **AUDIO HARDWARE TESTS** of the **SOUND TESTS** in this section of the manual).

Monitor Tests

The MONITOR TESTS provide patterns for verifying the monitor performance or making adjustments.

Use the TEST button to choose a particular menu item. Press the Left Throttle button to begin each test and to change variables during each test. The Left Thumb button ends the test.

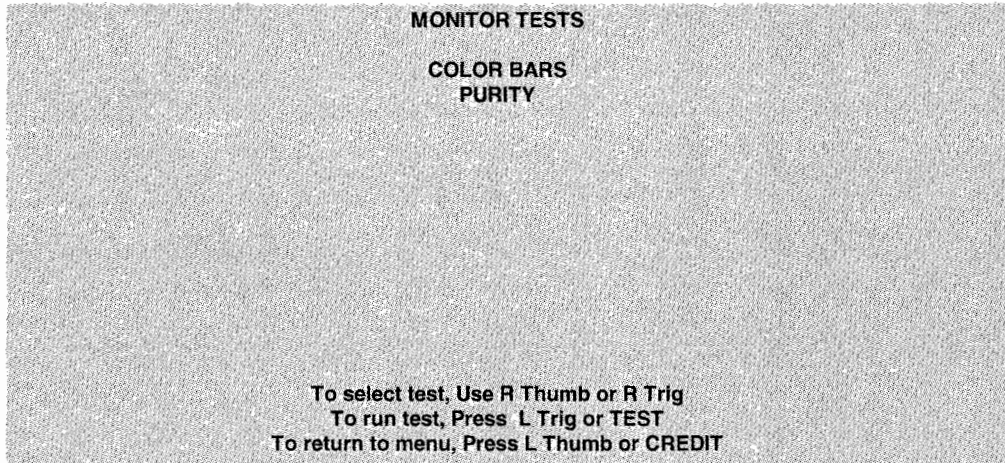

MONITOR TESTS MENU SCREEN

COLOR BARS fills the screen with shades of colors to verify red, green, blue and white level dynamic adjustments. Each color bar should appear sharp, clear, and distinct from bars on either side.

The Color Bars screen is useful in adjusting the monitor brightness and contrast.

Press the Left Throttle button twice to change the color of the screen border. Press Left Thumb button to exit.

PURITY fills the screen with 100% of the chosen color at normal intensity. Each screen should be absolutely uniform from top to bottom and side to side. No retrace lines or noise should be visible.

The Purity tests verify monitor intensity, black level, blanking and degaussing. There are eight separate color and brightness tests.

Press the Left Throttle button to cycle through the tests. With each press of the Left Throttle button, the screen briefly displays a new color and its name, then fills the screen entirely with the color. Press Left Thumb button to exit.

NOTE: If the monitor settings need correction, use the Monitor Remote Adjustment Board.

Disk Tests

The DISK TESTS verify the functions of the Hard Disk Drive Assembly. Some files can be repaired.

These tests are automatic and the results appear on the menu screen as they occur. There are no custom settings or adjustable variables in these tests. The Left Thumb button aborts the tests.

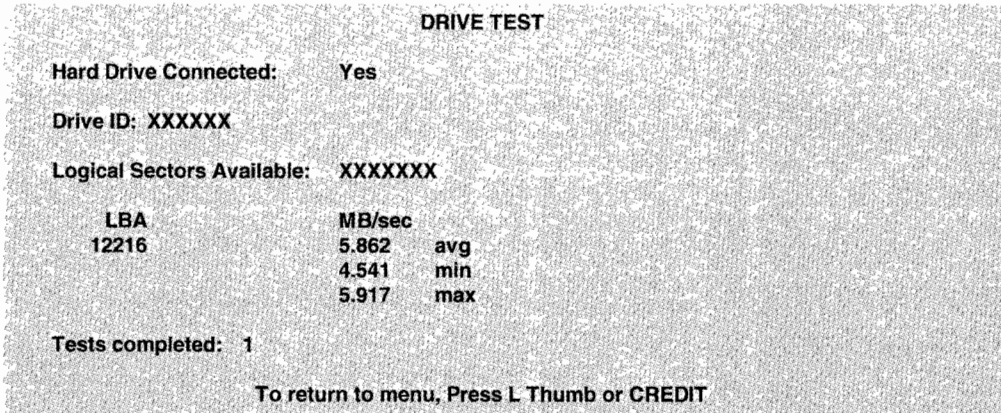

DRIVE TEST MENU SCREEN

Hard Drive Connected

This test routine verifies the interface between the CPU Board Assembly and the Hard Disk Drive itself. The processor requests disk information. Data cannot be retrieved successfully if there is a problem.

Drive ID

This is an industry standard identification for Hard Disk Drive type and capacity. This is a manufacturer hardware number only; it will not identify the software or the game program stored on the drive assembly.

Logical Sector Test

This test performs a sector by sector read/verify test on the disk drive. As the status of each block of sectors is checked, the speed of the data transfer is compared to its acceptance limits.

Tests Completed

These tests run over and over. The number increases each time the test cycle repeats (approx. every 5 minutes). After at least one cycle ("pass") is complete, press the Left Thumb button to end the test.

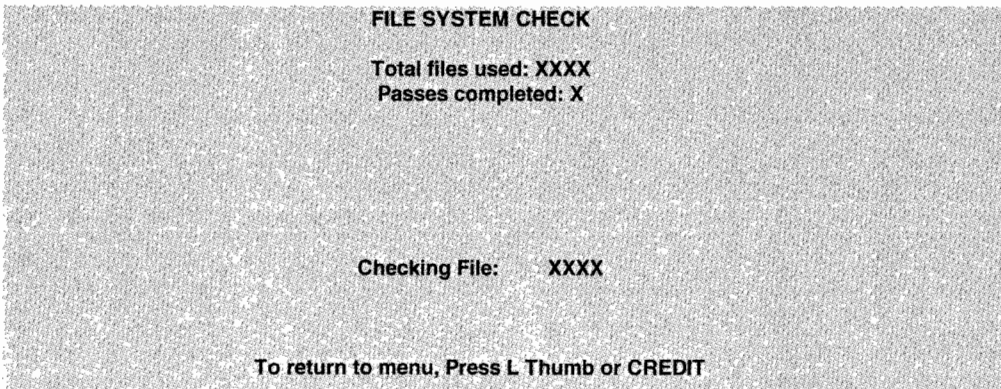

FILE SYSTEM TEST SCREEN

Checking File

This routine performs a file by file check of data stored on the hard disk drive and reports its findings. If there are errors, the system tries to fix them (approx. 5 minutes per cycle). The system reports on the severity of the errors and advises if they will affect game performance.

Network Tests

The NETWORK TESTS provide routines for verifying the communication circuits when games are linked. These tests are automatic and the results are reported on the menu screen as they occur.

There are no custom settings or adjustable variables in these tests. The Left Thumb button ends these tests.

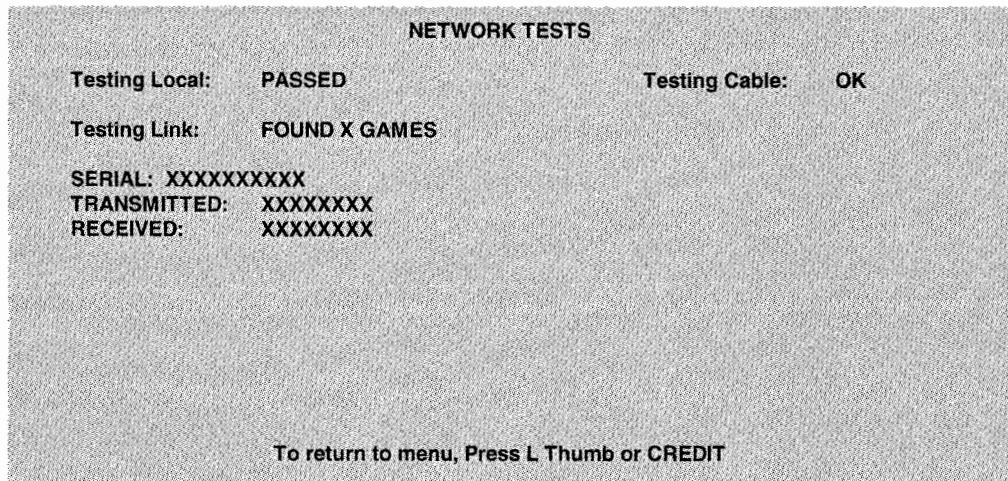

NETWORK TESTS MENU SCREEN

Several different options allow cabinet linking for head-to-head player competition. This screen allows the operator to determine if the linking equipment is networking or *not* working. The results of these tests either confirm proper operation or indicate the location of any problem. All linked games must be in network test mode to find any other games.

NOTE: This group of tests checks only system hardware (cables and communications circuits). Inspect for disconnected or broken cables, crossover couplers, hubs, etc. Individual games are not affected by network faults; however, network performance is critical for linked operation.

Testing Local

This test performs an internal check of the local communication circuits in the game cabinet. It does not test any cables, hubs, or the other game cabinets. An error message indicates CPU board difficulties.

Testing Cable

This verifies complete signal paths. "??" is a normal response to this test when the game is not linked. Linked games require all cabinets, couplers, hubs, etc. to be powered ON and connected to report OK.

Testing Link

This sends data out from each active game and looks for responses. At least two cabinets must be networked properly and in link testing mode for this test to report a result. The test reports the number of cabinets found. More linked games delay the test results response.

Transmitted

This number is a running count of the data packets sent by each game cabinet. It increases until you exit this screen. The local game location (your cabinet) is always listed first in the report.

Received

This number is a running count of the data packets acquired from the network. It increases until you exit. All cabinets must be receiving packets from the local cabinets or the communications network is faulty.

LINKED OPERATION

Equipment Requirements

Linked mode unites cabinets together and permits several players to race against each other in real time. As with single games, drone cars can be eliminated for head-to-head competition. The Linking program is player selectable so each cabinet can meet the needs of the players.

Games must be interconnected for linked operation. One cable is installed in each cabinet at the factory.

- ◆ **ALL GAMES** contain a crossover to connect two cabinets together.

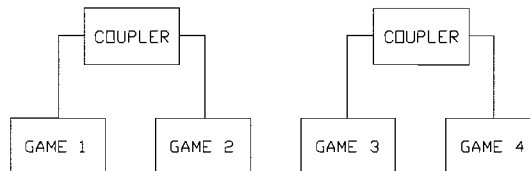

BASIC LINKING DIAGRAM

Each kit connects one pair of games. Passive electronics limit the cable length and the number of games. Cabinets are usually attached, but may be separated up to 30 ft. Linked pairs may be added as required.

- ◆ **HUB KITS** contain a network hub. The active circuits allow the use of more cables of greater length.

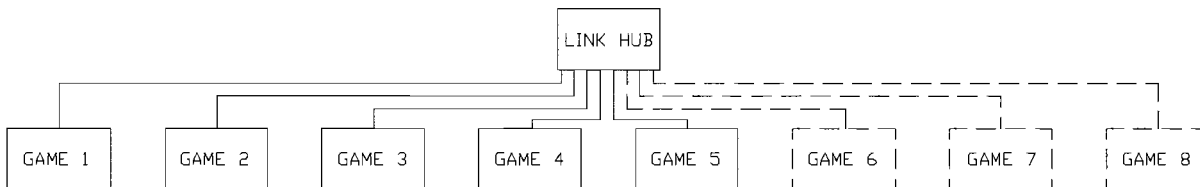

HUB LINKING DIAGRAM

Each kit connects from two to eight cabinets together. Active electronics permit use of larger networks. Cabinets are usually attached, but may be separated up to 300 ft. More cabinets can be added as needed.

Cabinets must communicate without errors before activating Linked Mode (refer to NETWORK TESTS).

Head-to-Head Racing

As a player selects a track, the opening screen LINKING indicator illuminates. A JOIN IN message offers subsequent players a linked race. If others do not begin their selection process before this message disappears from the screen, their games do not link (games operate independently for those players).

If other players begin the selection process while the JOIN IN message is visible, the cabinets begin sending and receiving information on the network. Each additional game gets data from active cabinets in exchange for its own packet containing a unique identity, car color, player preferences, etc. A WAITING message indicates that other individuals are still selecting options for this race. When the last player is done selecting or the waiting period has elapsed, all linked players see the START screen simultaneously.

Late arriving players cannot participate in an ongoing linked race, but they may begin an independent race. The link automatically breaks when the game ends, permitting another linked or solo race for each player.

SWITCHES AND JUMPERS

The CPU Board has a number of hardware variables that can be changed to adapt this assembly to other uses. Jumpers determine which circuit paths are active, and DIP switches select instructions.

◆ Switches

There is one CPU Board push button switch (S2, near the battery). This switch resets the processor. This switch is used during service to restart the game without cycling the power off and on again.

There are two DIP Switch blocks (U8 and U9, near the JAMMA connector) on this CPU Board set. Each consists of eight individual switches. These switches are factory set for normal game operation.

NOTE: All instruction variables for this game are software selectable from the menu system. Each DIP Switch should be set to its OFF position (Factory default) for proper game operation.

◆ Jumpers

Jumpers on the CPU Board match various system characteristics to optimize the memory circuits and video signals. These jumpers may require adjustment to accommodate future upgrades or service.

NOTE: The circuit paths are optimized at the factory during the board test procedure. Each jumper should be left in its original position to avoid error messages or video sync problems.

ERRORS

The system detects errors at start up or during various diagnostic tests or operations and reports them on the screen. Some errors, such as minor disk data faults, are automatically repaired by the system. Other errors, such as player control calibration, are fixed by manually resetting the values in game memory. In most cases, the game will continue to operate with reduced performance after discovering minor errors.

Always record error messages before attempting to correct any problem. The USER MESSAGES report may store some additional temporary messages (refer to STATISTICS earlier in this section).

After recording the error messages, turn off the game's power, wait a few minutes, then turn the power back on again. Pay attention to the start-up screens and note any error messages during the Power On Tests. If possible, enter the SELF TEST MENU SYSTEM and run all of tests related to where the errors occurred. Record any new error messages and compare them to those previously recorded to determine whether the errors are random or continuous in nature.

NOTE: Do not ignore error messages when the game can be forced to start and operate. Games with errors may generate reduced earnings due to poor performance.

VAPOR TRX™



SECTION TWO

PARTS

Warning

USE OF NON-ATARI PARTS OR CIRCUIT MODIFICATIONS MAY CAUSE SERIOUS INJURY OR EQUIPMENT DAMAGE! USE ONLY ATARI AUTHORIZED PARTS.

* For safety and reliability, substitute parts and modifications are not recommended.

* Substitute parts or modifications may void FCC type acceptance.

A-22114 MAIN CABINET AND SEAT ASSEMBLY

FRONT VIEW

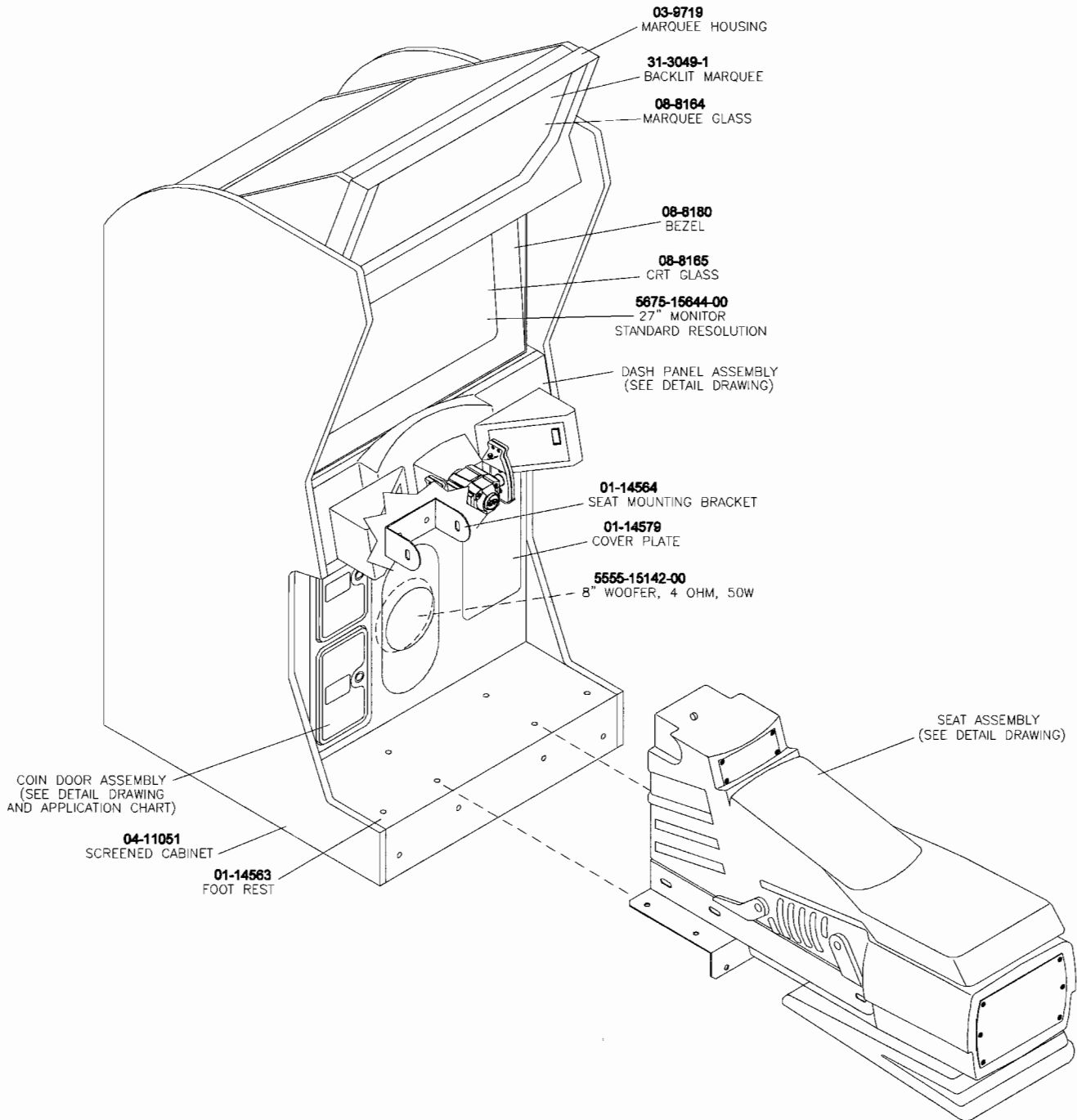

A-22114 MAIN CABINET AND SEAT ASSEMBLY

REAR VIEW

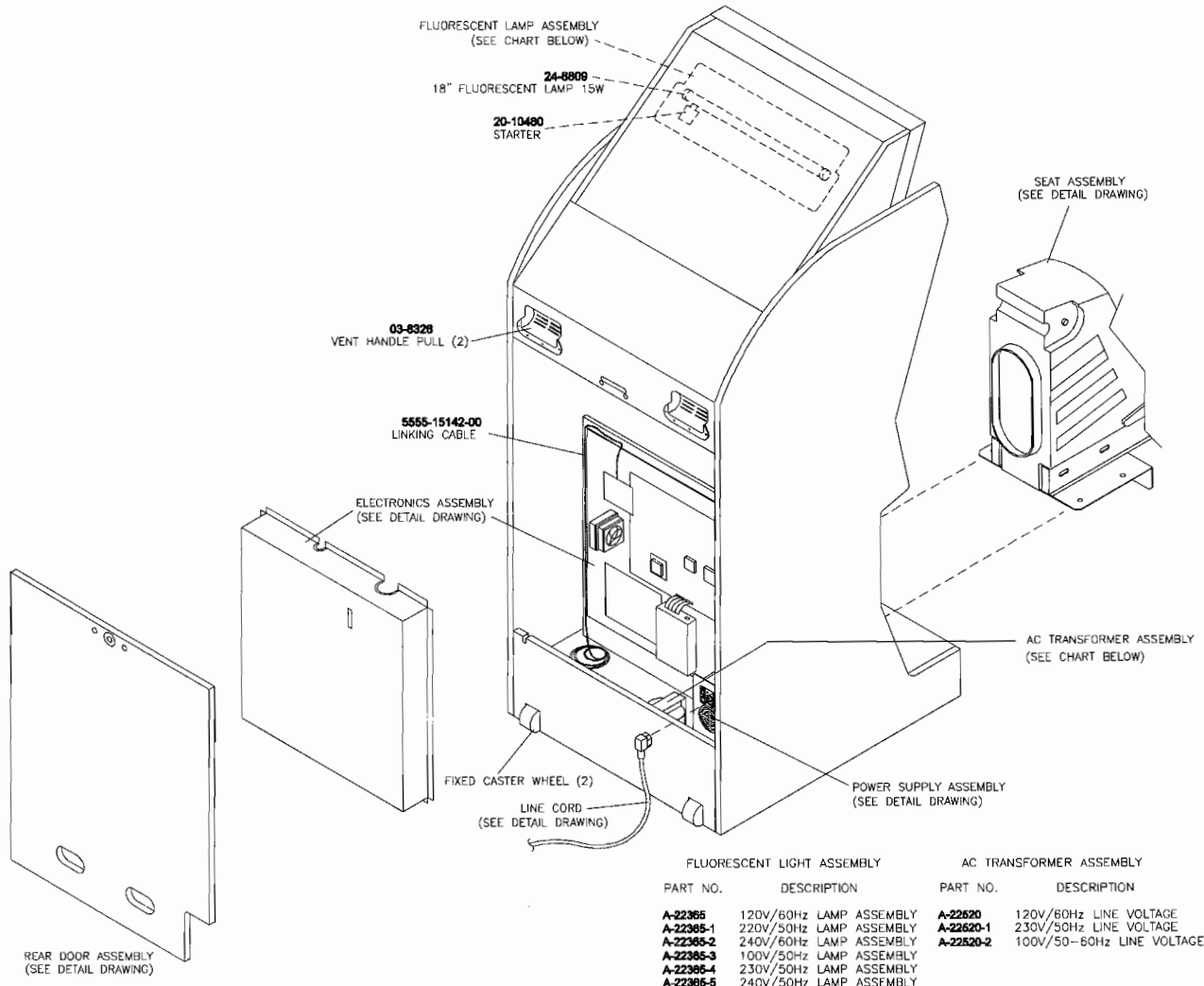

| FLUORESCENT LIGHT ASSEMBLY | | | AC TRANSFORMER ASSEMBLY | | |
|----------------------------|-------------|---------------|-------------------------|--------------|--------------|
| PART NO. | DESCRIPTION | | PART NO. | DESCRIPTION | |
| A-22365 | 120V/60Hz | LAMP ASSEMBLY | A-22520 | 120V/60Hz | LINE VOLTAGE |
| A-22365-1 | 220V/50Hz | LAMP ASSEMBLY | A-22520-1 | 230V/50Hz | LINE VOLTAGE |
| A-22365-2 | 240V/60Hz | LAMP ASSEMBLY | A-22520-2 | 100V/50-60Hz | LINE VOLTAGE |
| A-22365-3 | 100V/50Hz | LAMP ASSEMBLY | | | |
| A-22365-4 | 230V/50Hz | LAMP ASSEMBLY | | | |
| A-22365-5 | 240V/50Hz | LAMP ASSEMBLY | | | |
| A-22365-6 | 220V/60Hz | LAMP ASSEMBLY | | | |

A-22121 SEAT MODULE ASSEMBLY

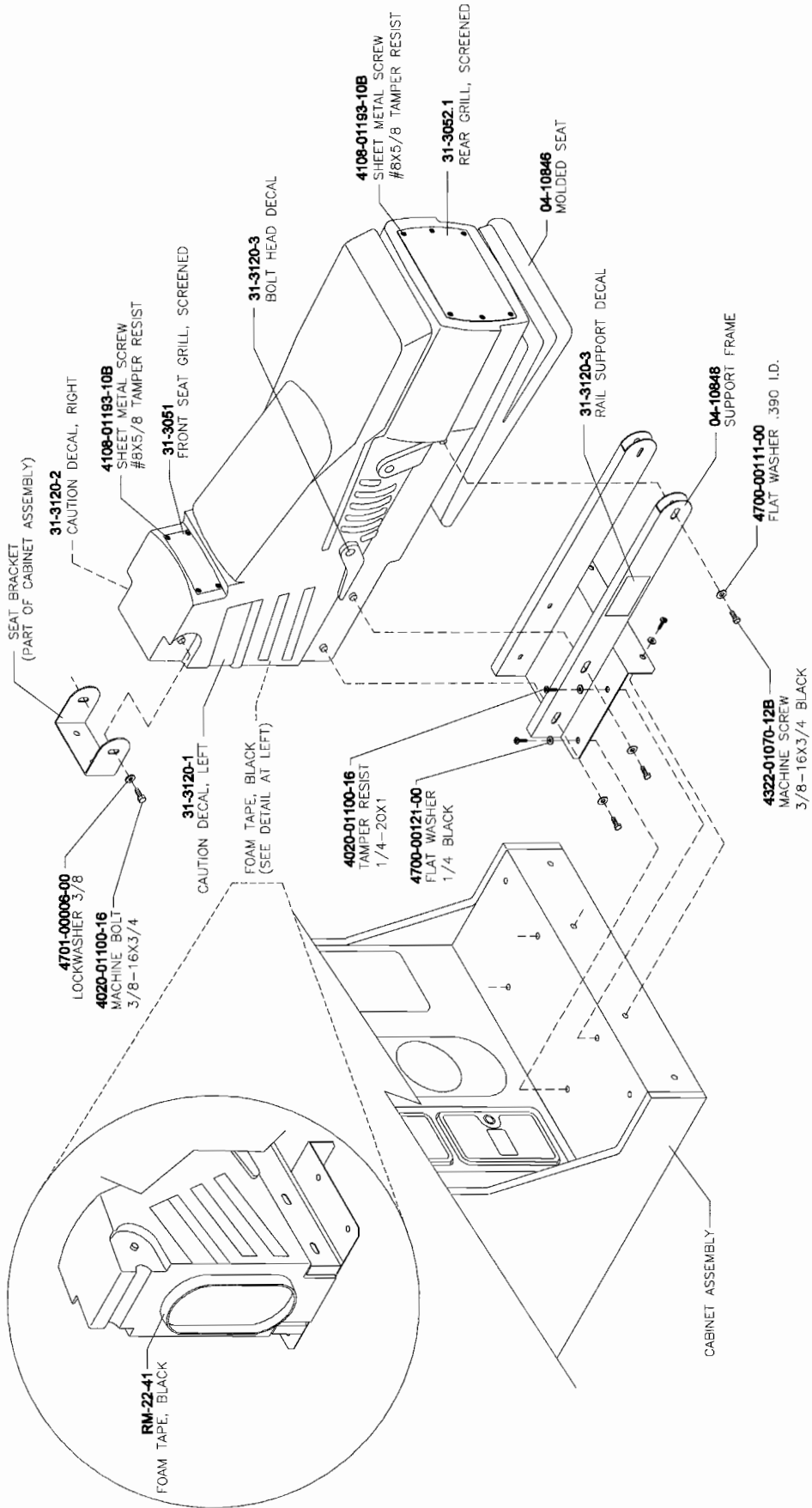

CASTER/LEVELER KITS (30024)

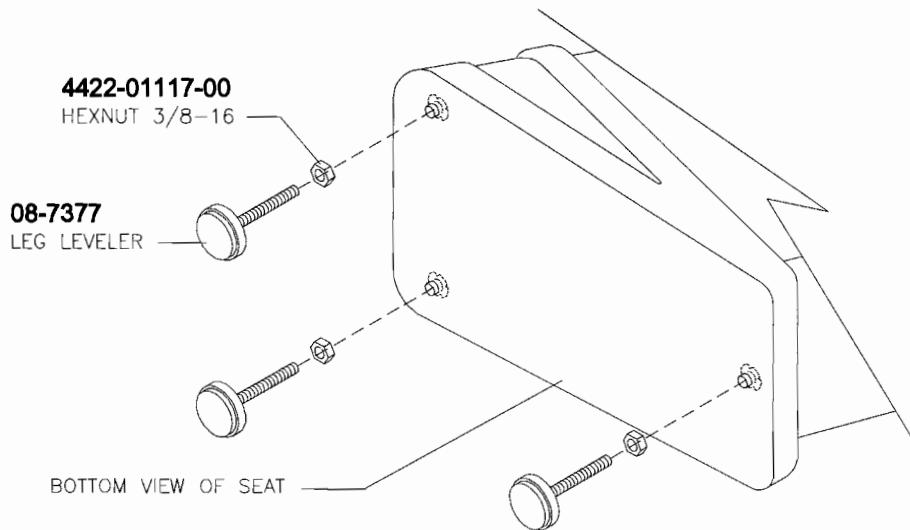
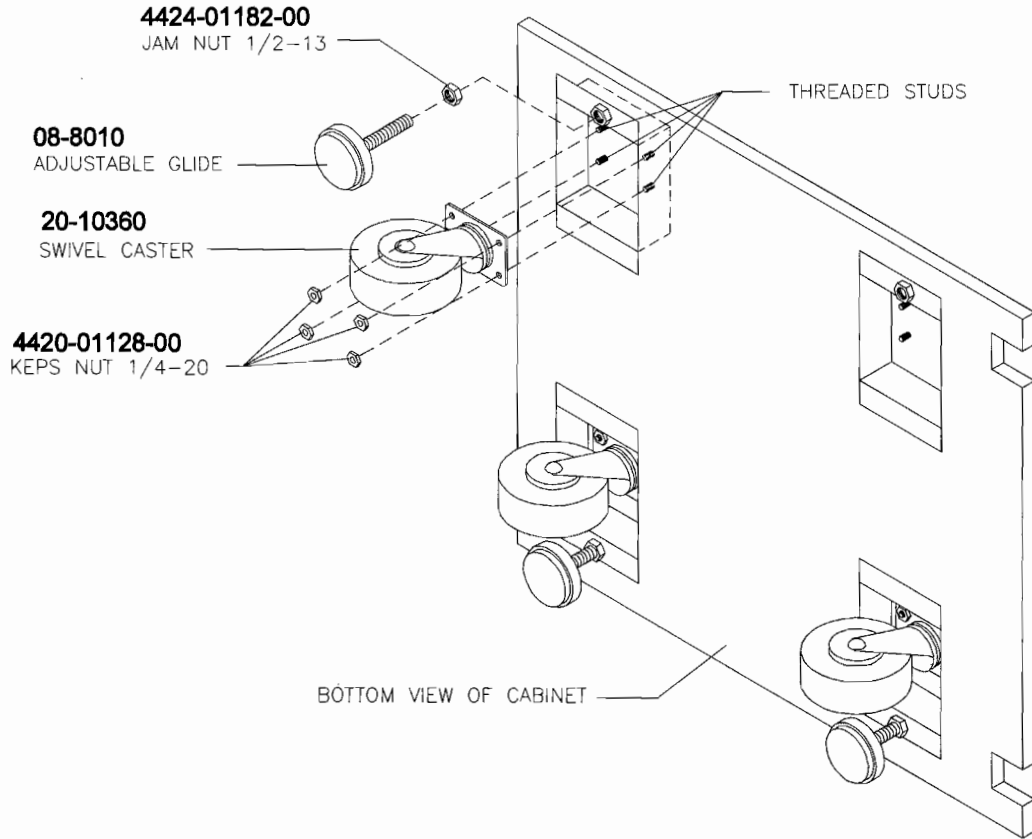

FLIGHT CONTROL ASSEMBLY A-22366

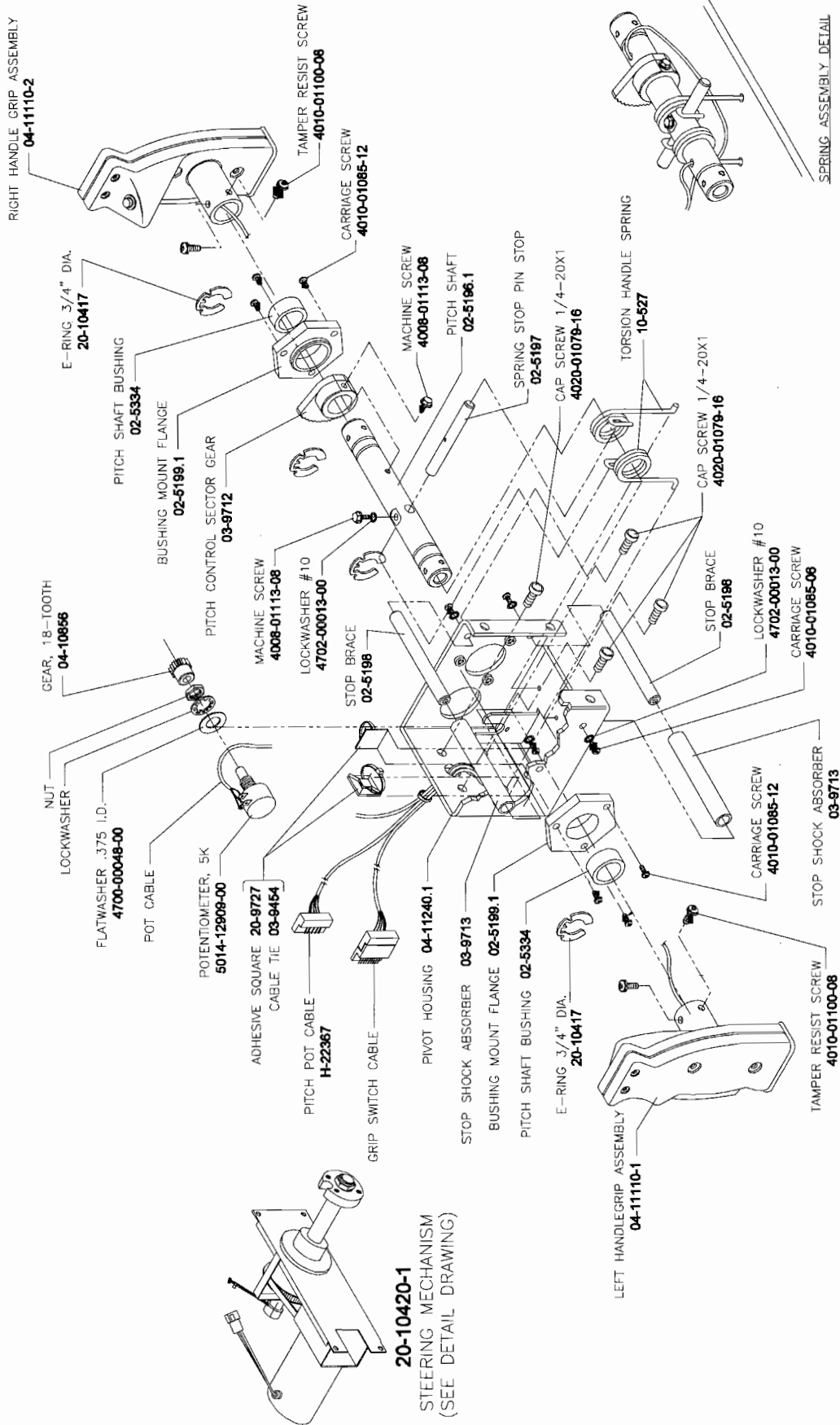

A-22119 DASH PANEL ASSEMBLY

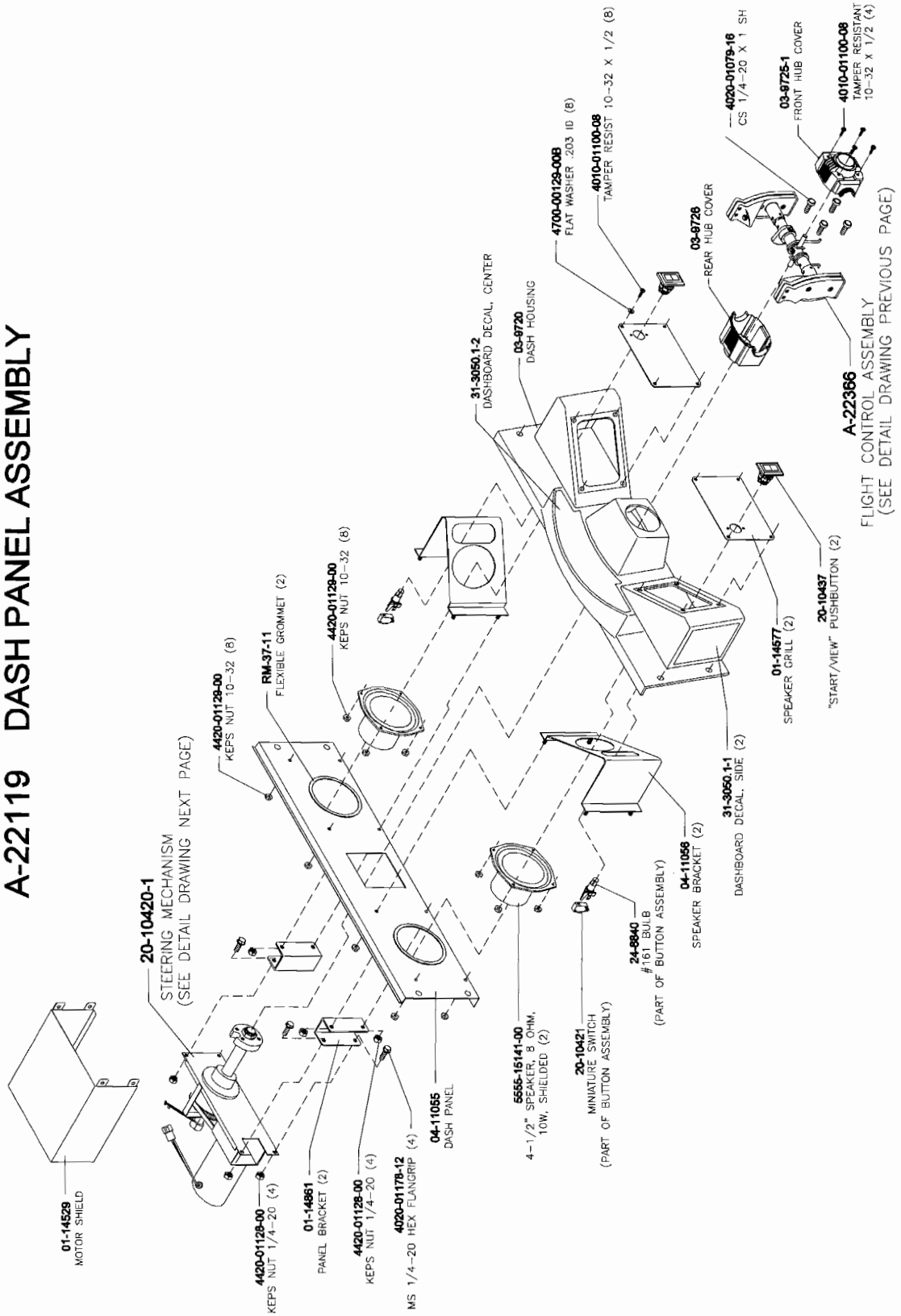

20-10420-1 STEERING MECHANISM

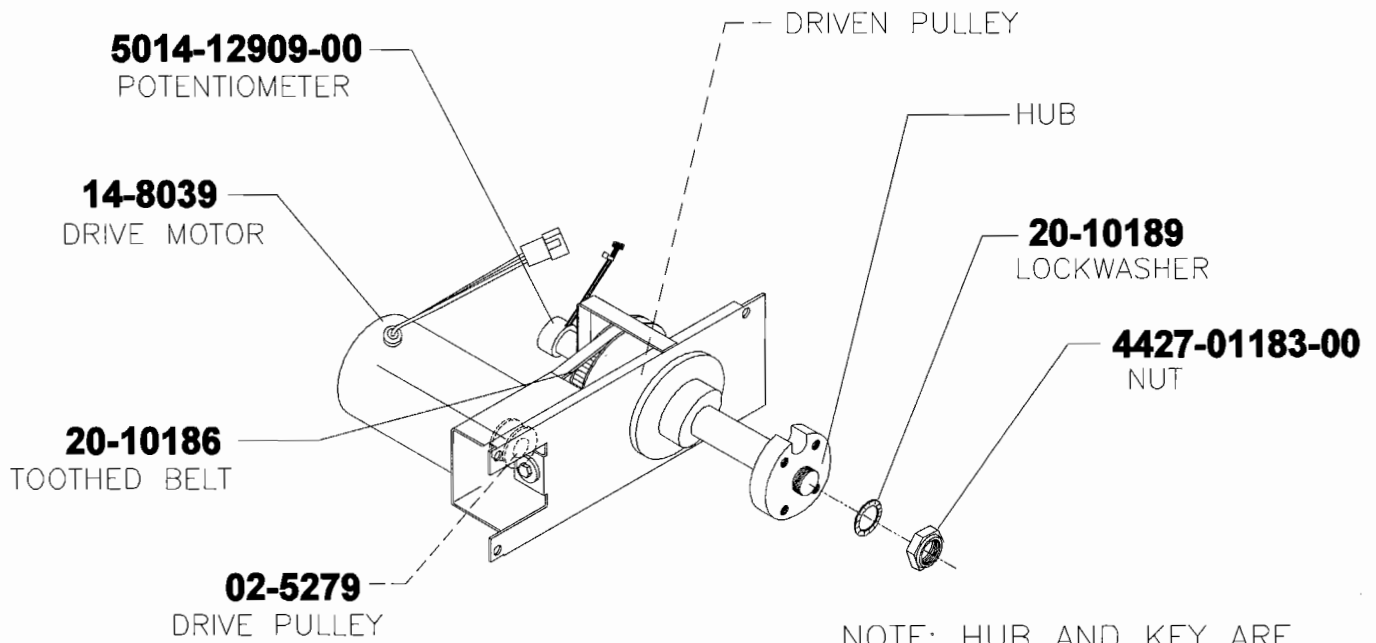

NOTE: HUB AND KEY ARE PERMANENTLY BONDED TO SHAFT.

COIN DOOR ASSEMBLY

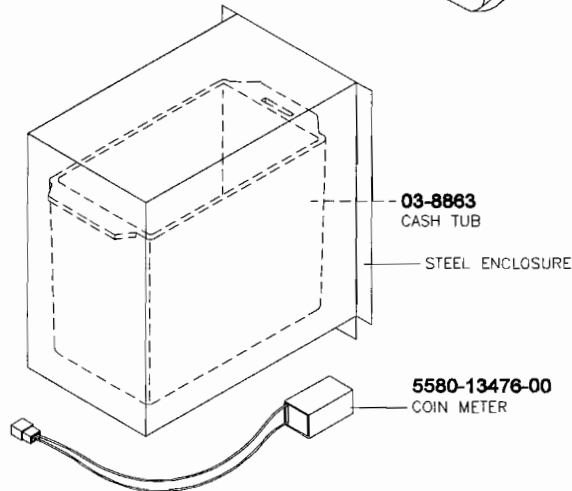
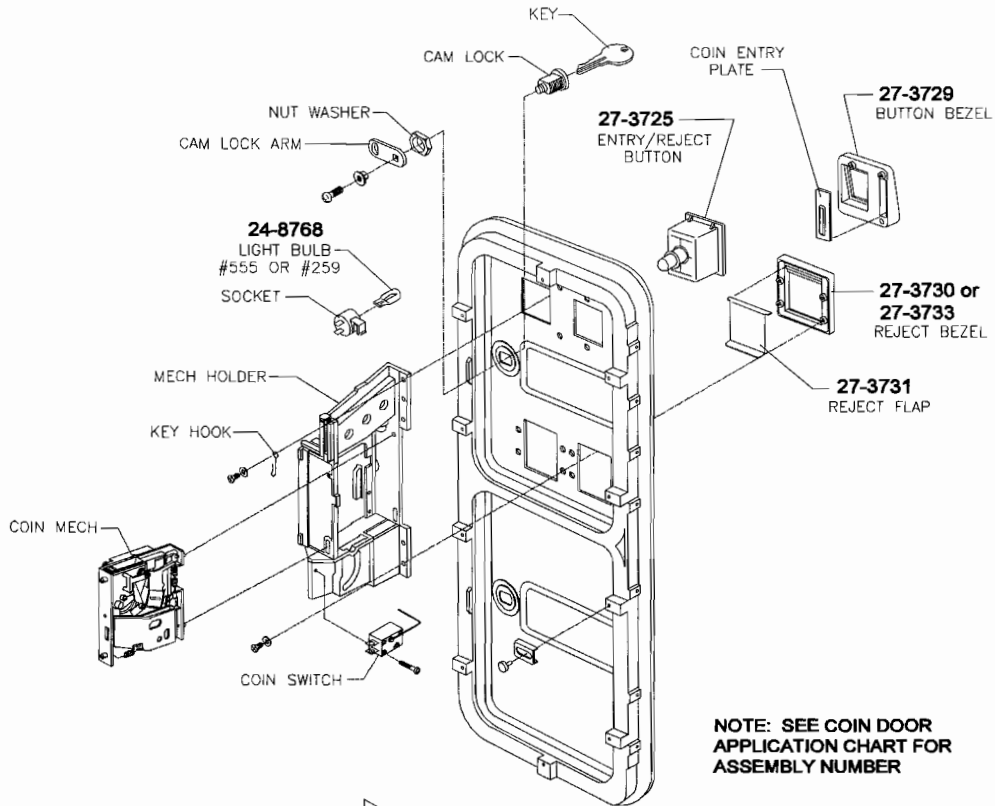

COIN DOOR APPLICATION CHART

| Country | Part Number |
|----------------|--------------|
| United States | 09-72000-1 |
| United Kingdom | 09-22000-V-1 |
| Japan | 09-72000-15 |

Note: The United Kingdom coin door requires Electronic Coin Mechanism Assembly part number 04-11139-3. The other coin doors include coin mechanisms.

A-22122 POWER SUPPLY ASSEMBLY

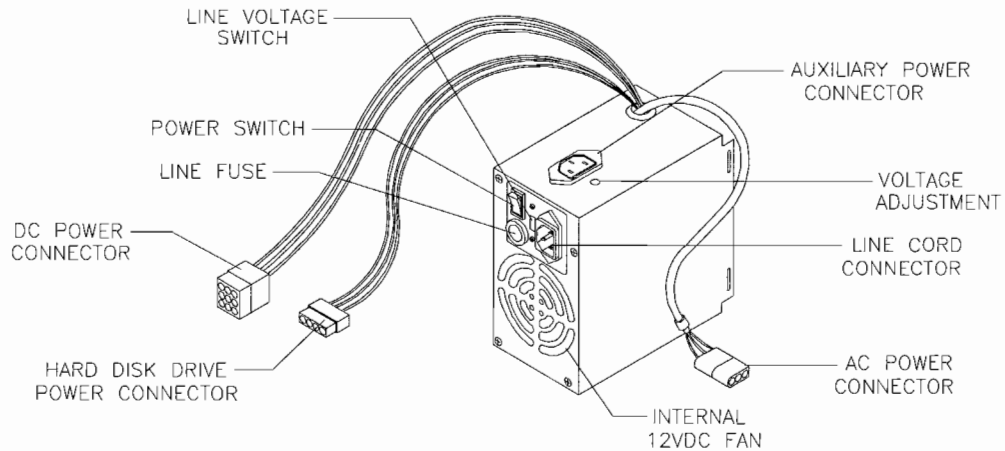

A.C. AUXILIARY POWER CONNECTOR

| PINS | FUNCTION | COLOR |
|------|----------|-------|
| 1 | LINE | BLACK |
| 2 | GROUND | GREEN |
| 3 | NEUTRAL | WHITE |

D.C. MAIN POWER CONNECTOR

| PINS | FUNCTION | COLOR |
|-------|----------|--------|
| 1,2,3 | +5 VDC | RED |
| 4,5,6 | RETURN | BLACK |
| 7 | -5 VDC | BLUE |
| 8 | +12 VDC | YELLOW |
| 9 | -12 VDC | WHITE |

HARD DISK DRIVE POWER CONNECTOR

| PINS | FUNCTION | COLOR |
|------|----------|--------|
| 1 | +5 VDC | RED |
| 2,3 | RETURN | BLACK |
| 4 | +12 VDC | YELLOW |

NOTE: Many computer grade power supplies use alternate wire colors. This is acceptable as long as the pinout is correct.

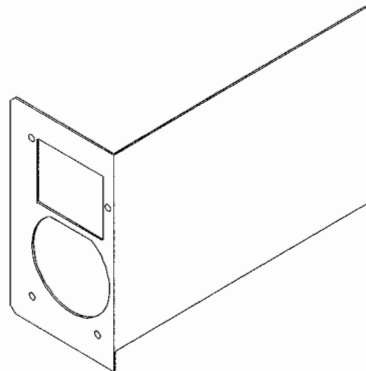

04-11091
POWER SUPPLY BRACKET

LINE CORD APPLICATION CHART

Country

United States
United Kingdom
Japan

Part Number

5850-15521-01
5850-14699-03
5850-15521-06

REAR DOOR LOCKING HASP ASSEMBLY

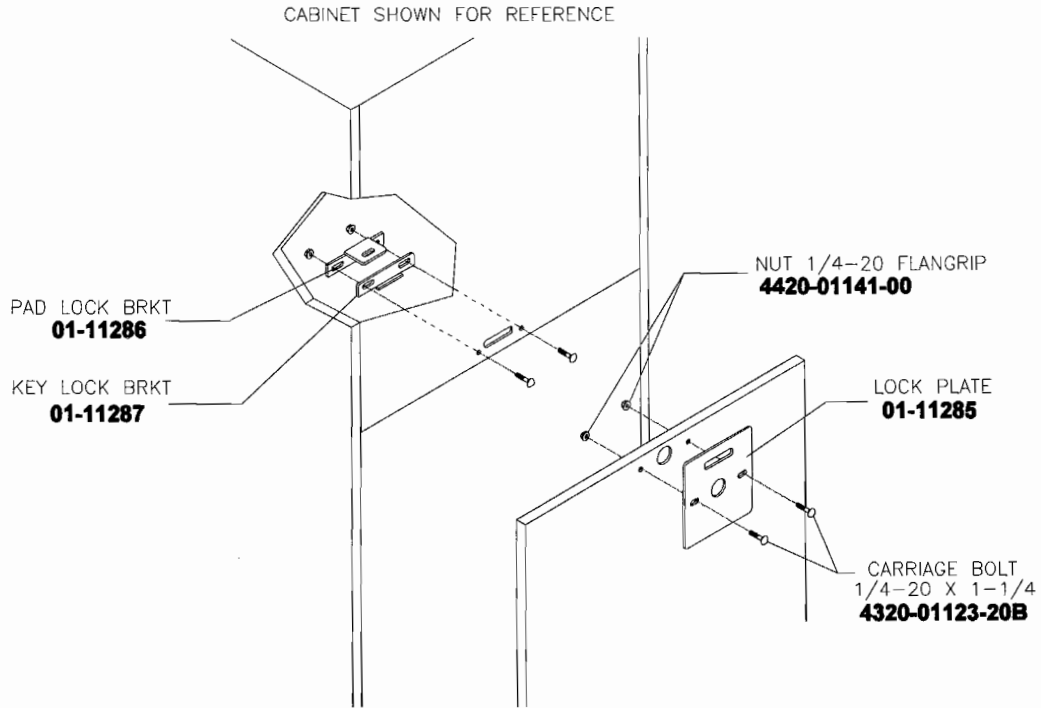

REAR DOOR ASSEMBLY A-22120

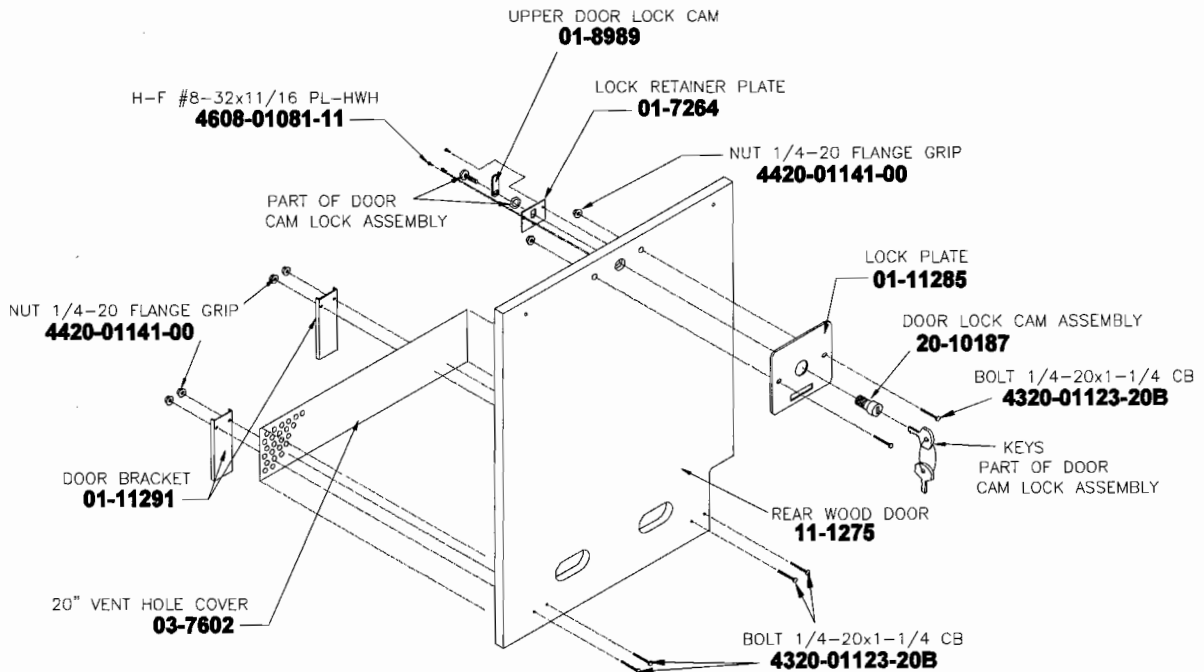

A-22115 ELECTRONICS ASSEMBLY (30024)

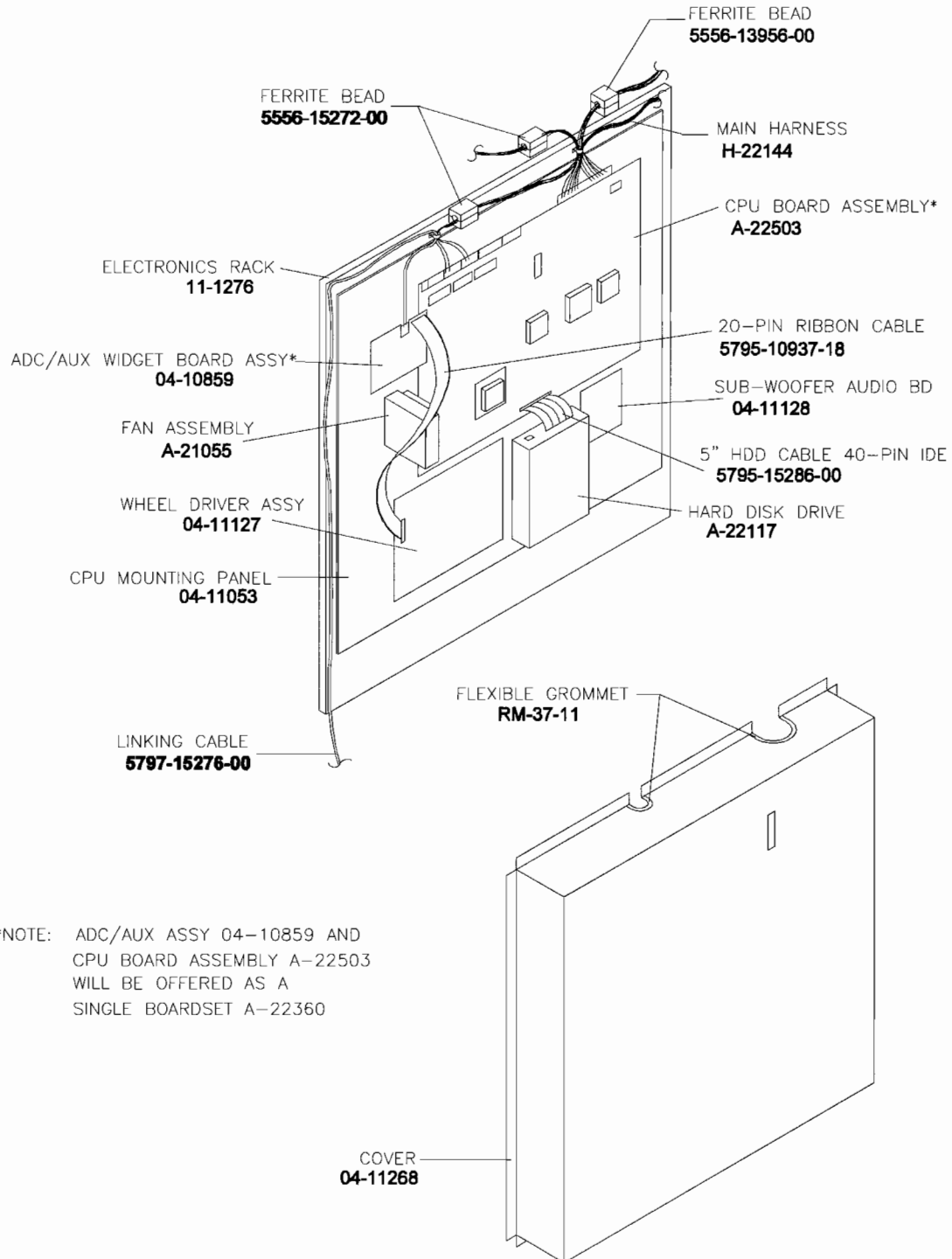

*NOTE: ADC/AUX ASSY 04-10859 AND CPU BOARD ASSEMBLY A-22503 WILL BE OFFERED AS A SINGLE BOARDSET A-22360

A-22503 CPU BOARD ASSEMBLY

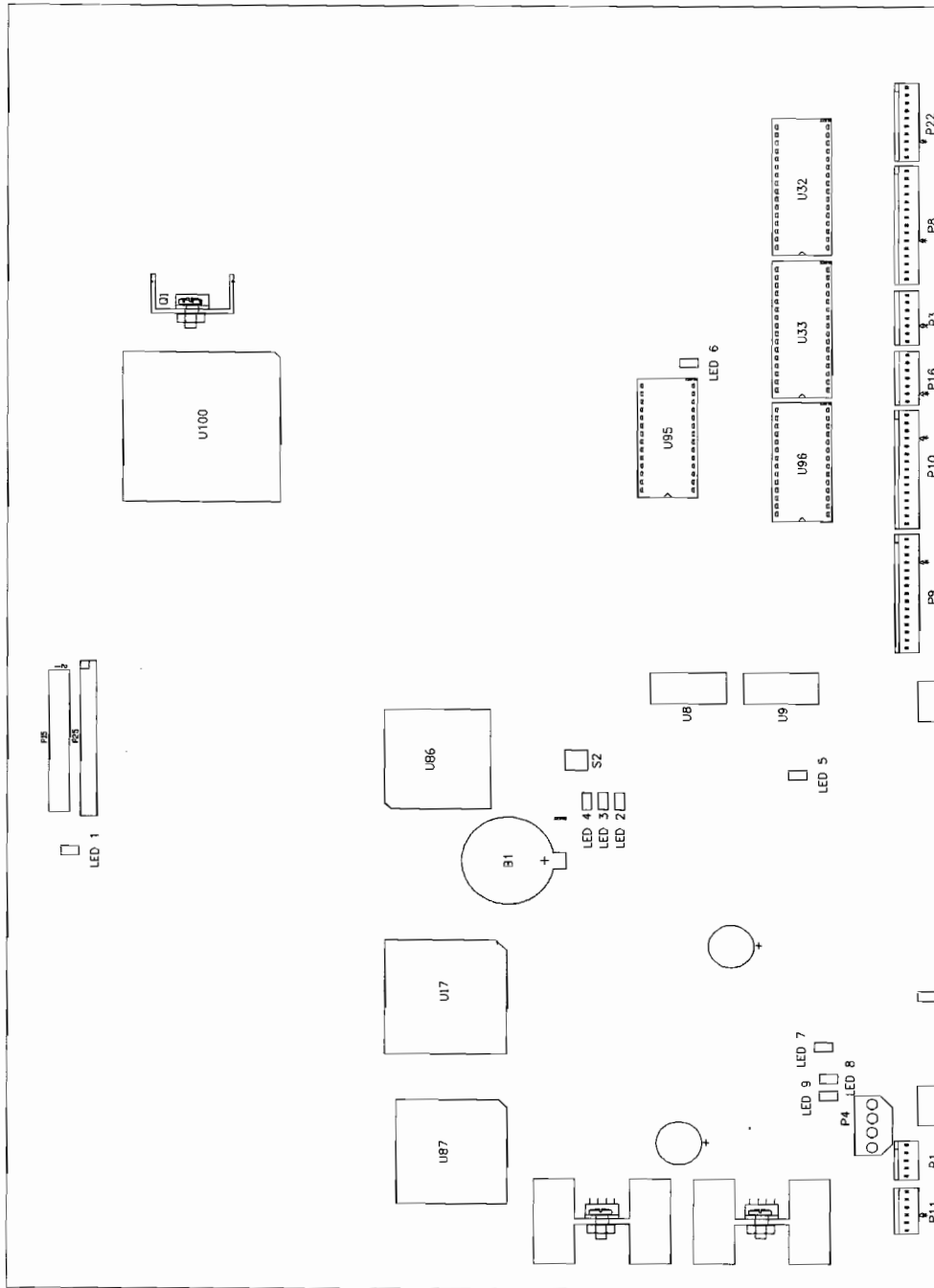

Field Replaceable Parts

| DESIGNATION | PART NUMBER | FUNCTION | DESCRIPTION |
|-------------|----------------|--------------------|-----------------------|
| B1 | 5880-11056-00 | Memory Backup | 3Volt Lithium Battery |
| U32 | A-5343-30024-1 | CPU Boot ROM | EPROM Assembly |
| U33 | --- | Boot Expansion ROM | EPROM Assembly |
| U95 | A-5343-30024-2 | Sound Boot ROM | EPROM Assembly |
| U96 | A-22504 | Video PIC | EPROM Assembly |
| U100 | 04-11048.4 | Microprocessor | CPU Assembly |

04-11128 SOUND SUB-WOOFER ASSEMBLY

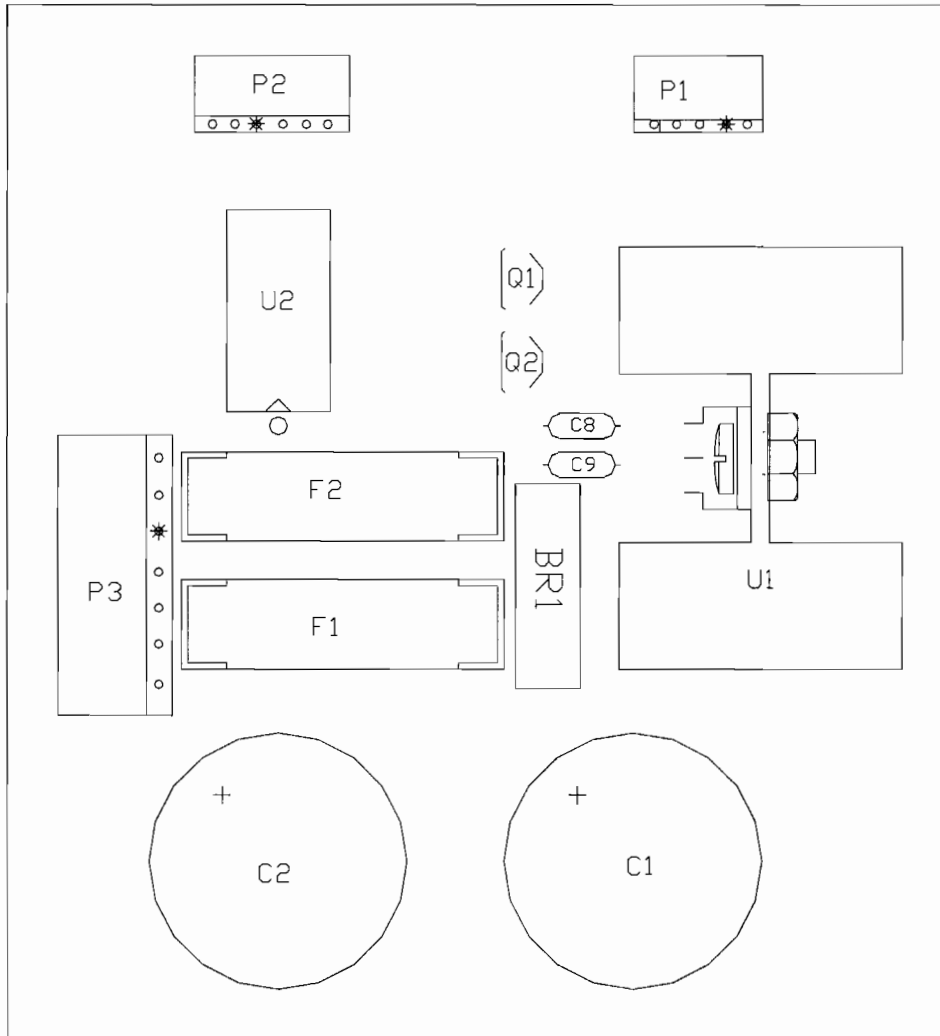

Field Replaceable Parts

| <i>Designation</i> | <i>Description</i> | <i>Part Number</i> | <i>Function</i> |
|--------------------|---------------------------|--------------------|--------------------|
| U1 | Heat Sink | 5705-12638-00 | Device Cooling |
| U1 | TDA 2030A | 5370-13419-00 | Audio Amplifier |
| U1 | Screw | 4004-01005-06 | Mounts Amplifier |
| U1 | Nut | 4404-01124-00 | Mounts Amplifier |
| F1, F2 | Fuse 2.5A, 250V, 5x20mm | 5731-14532-00 | Circuit Protection |
| BR1 | Rectifier 4A, 100V, GBL02 | 5100-13945-01 | Bridge Rectifier |
| Q1 | Voltage Regulator 78L05 | 5250-13302-00 | +5V Regulator |
| Q2 | Voltage Regulator 79L05 | 5250-13303-00 | -5V Regulator |

04-11127 WHEEL DRIVER BOARD ASSEMBLY

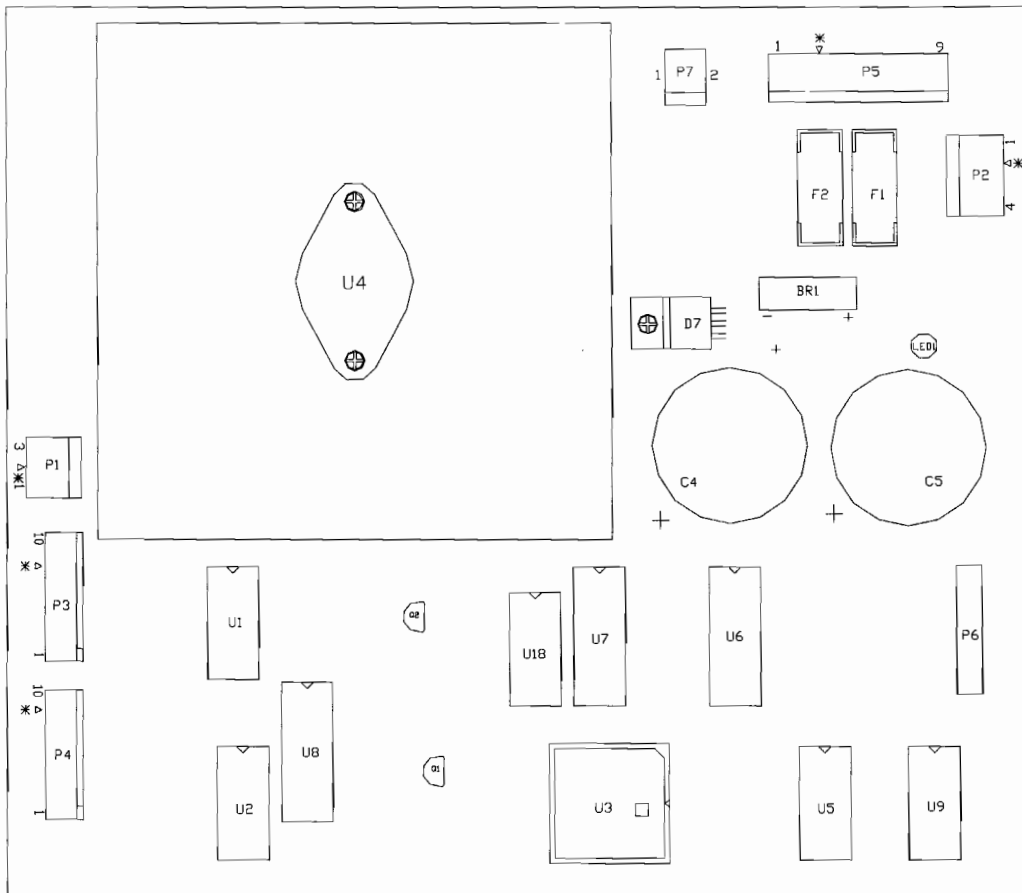

Field Replaceable Parts

| <i>Designation</i> | <i>Description</i> | <i>Part Number</i> | <i>Function</i> |
|--------------------|----------------------------|----------------------|----------------------|
| IC1, IC2 | ULN2064 Integrated Circuit | 5370-12602-00 | Lamp Drivers |
| IC5 | 26LS32A Integrated Circuit | 5340-12959-00 | Control Circuit |
| IC6 | 74LS541 Integrated Circuit | 5281-12887-00 | Control Circuit |
| IC7, IC8 | 74HC574 Integrated Circuit | 5311-14068-00 | Data Latch |
| IC9 | 26LS31 Integrated Circuit | 5340-12958-00 | Data Output |
| IC18 | DAC 0800 | 5371-14070-00 | Wheel Output |
| U3 | PLCC Assembly | 5700-13173-00 | Control Instructions |
| U4 | LM12 Power Op-Amp | 5370-14069-00 | Motor Driver |
| BR1 | Bridge Diode SIP, 4A, 100V | 5100-13945-01 | Rectifier |
| D7 | Diode MUR1605 | 5070-15115-00 | Clamp Diode |
| Q1 | Transistor 2N6427 | 5162-08976-00 | Timing Circuit |
| Q2 | Transistor 2N3904 NPN | 5160-10269-00 | Signal Inverter |
| F1, F2 | Fuse 4A, 250V, 5x20mm, SB | 5731-14094-00 | Circuit Protection |

04-10859 ADC/AUX WIDGET BOARD ASSEMBLY

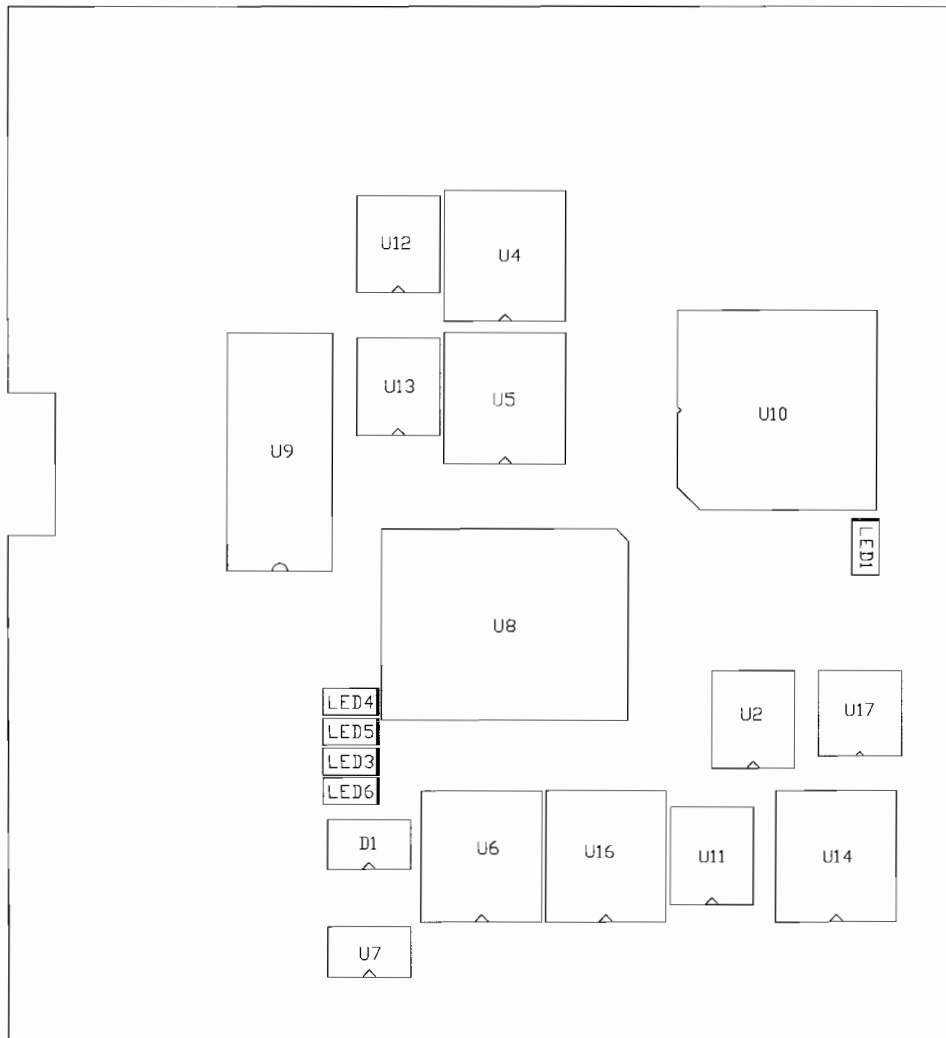

NOTE: There are no field replaceable parts in this assembly at this time.

Other Parts Necessary

Power and Protection

| | |
|--------------------------------|----------------------|
| A.C. Line Filter, 6A, 250V | 5102-14240-00 |
| Fuse, 3AG, 250V, 1A | 5730-15278-00 |
| Fuse, 3A, 250V, 5 x 22 mm | 5731-14468-00 |
| Fuse, 4A, 250V, 5 x 20 mm, SB | 5731-14094-00 |
| Fuse, 2.5A, 250V, 5 x 20 mm | 5731-14532-00 |
| Bulb, Incandescent, 14V, #161 | 24-8840 |
| Bulb, Incandescent, 6.3V, #555 | 24-8768 |

Cables

| | |
|---------------------------------|----------------------|
| Main Harness Cable | H-22144 |
| Speaker Cable Assembly (2) | H-22304 |
| View Cable Assembly (2) | H-22305 |
| Fluorescent Lamp Cable Assembly | H-21492 |
| AC Harness | H-22303 |
| IEC AC Power Cord | 5350-15521-01 |
| FFB Pot Cable | H-22368 |
| Pitch Pot Cable | H-22367 |
| Ground Wire | H-21672 |

Documents

| | |
|---------------------------------|------------------|
| Product Registration Card | 16-9478.2 |
| DBV Installation Instructions | 16-9637 |
| Hard Drive Handling Guide | 16-10076 |
| Electronic Device Caution Sheet | 16-10077 |

Tools

| | |
|---------------|-----------------|
| T-20 Torx key | 20-9620 |
| T-27 Torx key | 20-10140 |

VAPOR TRX™



SECTION THREE

WIRING

Warning

Failure to reconnect all ground wires or replace metal shields and covers with each mounting screw installed and securely tightened may result in radio frequency interference.

Edge Connector Chart

| FUNCTION | WIRE COLOR | PIN | PIN | WIRE COLOR | FUNCTION |
|--------------------|---------------|-----|-----------------------|--------------|------------------|
| Ground | Black | A | 1 | Black | Ground |
| Ground | Black | B | 2 | Black | Ground |
| +5VDC | Red | C | 3 | Red | +5VDC |
| +5VDC | Red | D | 4 | Red | +5VDC |
| Not Used | N/C | E | 5 | Yellow | -5VDC |
| +12VDC | Orange | F | 6 | Orange | +12VDC |
| Key | N/C | H | 7 | N/C | Key |
| Not Used | N/C | J | 8 | Brown | Coin Counter 1 |
| Not Used | N/C | K | 9 | N/C | Not Used |
| Speaker -, Left | Brown/Grey | L | 10 | Red/Grey | Speaker +, Left |
| Speaker -, Right | Brown/White | M | 11 | Red/White | Speaker +, Right |
| Video Green | Yellow/Green | N | 12 | Yellow/Red | Video Red |
| Video Sync | Yellow/White | P | 13 | Yellow/Blue | Video Blue |
| Service Credits | White/Grey | R | 14 | Yellow/Black | Video Ground |
| Slam/Tilt | Black/Green | S | 15 | Black/Blue | Test |
| Right Coin | Black/Red | T | 16 | Black/Brown | Left Coin |
| Not Used | N/C | U | 17 | White | Left Throttle |
| Not Used | N/C | V | 18 | N/C | Not Used |
| Left Switch | Violet/Brown | W | 19 | N/C | Not Used |
| Not Used | N/C | X | 20 | N/C | Not Used |
| Right Switch | Violet/Orange | Y | 21 | N/C | Not Used |
| Not Used | N/C | Z | 22 | White/Yellow | Right Throttle |
| Not Used | N/C | a | 23 | White/Green | Left Thumb |
| Not Used | N/C | b | 24 | White/Blue | Right Thumb |
| Not Used | N/C | c | 25 | N/C | Not Used |
| Not Used | N/C | d | 26 | N/C | Not Used |
| Ground | Black | e | 27 | Black | Ground |
| Ground | Black | f | 28 | Black | Ground |
| SOLDER SIDE | | | COMPONENT SIDE | | |

Dashboard Wires Not Part of Edge Connector

| FUNCTION | WIRE COLOR | PIN | PIN | WIRE COLOR | FUNCTION |
|------------------|--------------|-----|-----|-------------|-------------------|
| Left Start Lamp | White/Red | - | 2 | Red | +5V Up/Down |
| Left Start Lamp | Orange | + | 5 | White/Brown | -11.5V to -13.5V |
| Right Start Lamp | White/Orange | - | 15 | Black | Ground Up/Down |
| Right Start Lamp | Orange | + | 1 | Red | +5V Left/Right |
| Wheel Motor | White | 1 | 4 | White/Black | Sense Left/Right |
| Wheel Motor | Black | 2 | 14 | Black | Ground Left/Right |

D.C. Power Source Voltage Limits

| FUNCTION | RANGE LIMITS | COLOR | COLOR | RANGE LIMITS | FUNCTION |
|------------------|------------------|--------|--------|------------------|-----------------|
| Digital Circuits | +4.90V to +5.10V | Red | Yellow | -4.75V to -5.25V | Coin Lights |
| Audio, Lights | +11.5V to +13.5V | Orange | Blue | -11.5V to -13.5V | Auxiliary Power |

| FUNCTION | RANGE LIMITS | VOLTS | VOLTS | RANGE LIMITS | FUNCTION |
|-----------------|------------------|--------|--------|------------------|---------------|
| Steering Driver | +32.0V to +40.0V | +36VAC | +22VAC | +20.0V to +24.0V | Woofers Audio |

CABINET WIRING DIAGRAM

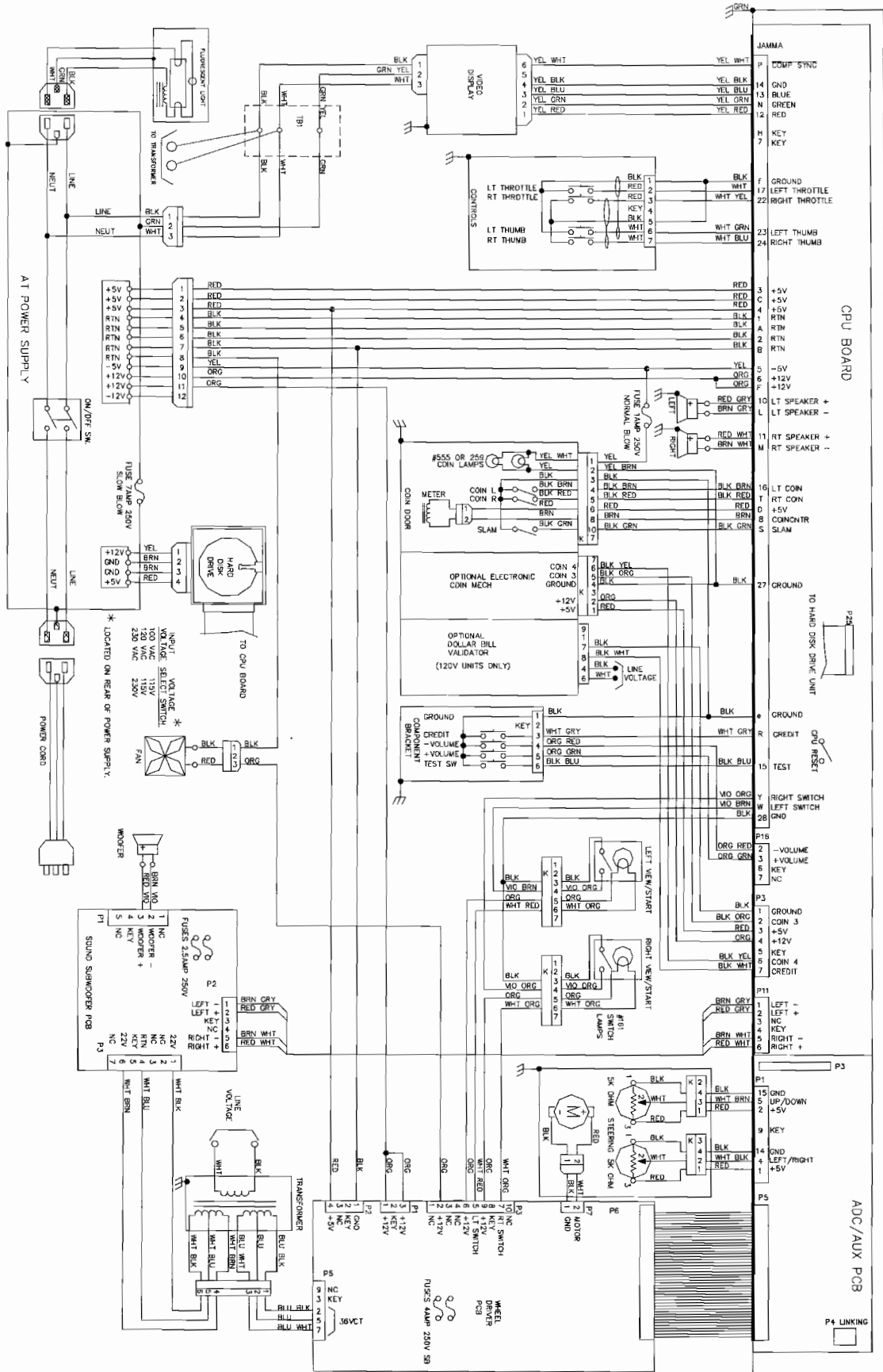

POWER WIRING DIAGRAM

| FUSE APPLICATION CHART | |
|------------------------|-------------|
| LINE VOLTAGE | FUSE RATING |
| 120 | 4A SB 250V |
| 230 | 2A SB 250V |

NOTE: THERE ARE 4 ITEMS THAT MUST BE CHANGED FOR OPERATION ON OTHER LINE VOLTAGES:

1. RATING OF POWER SUPPLY FUSE
2. FLUORESCENT LAMP ASSEMBLY
3. VOLTAGE SWITCH ON POWER SUPPLY
4. A.C. POWER TRANSFORMER

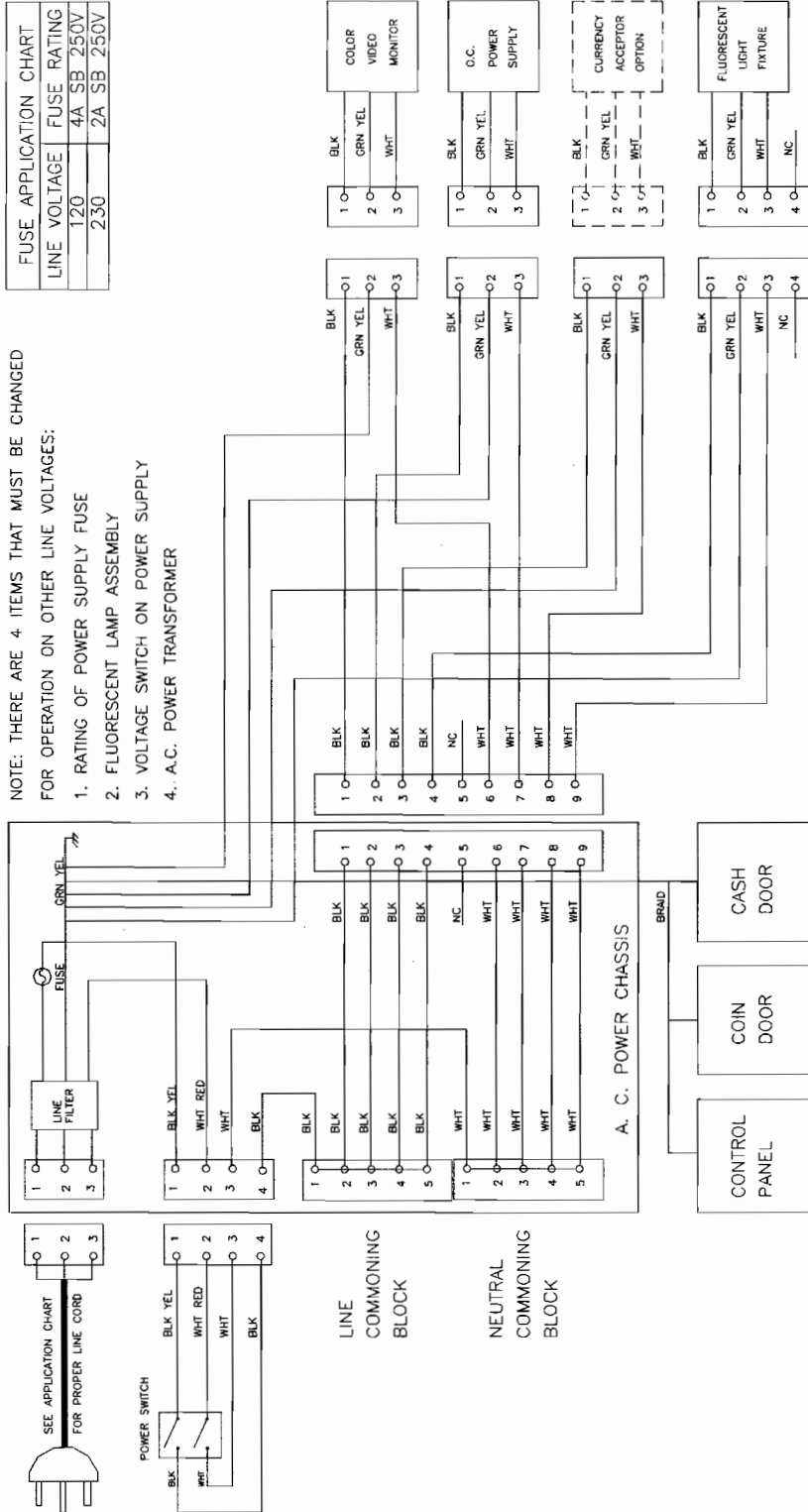

DOLLAR BILL VALIDATOR WIRING

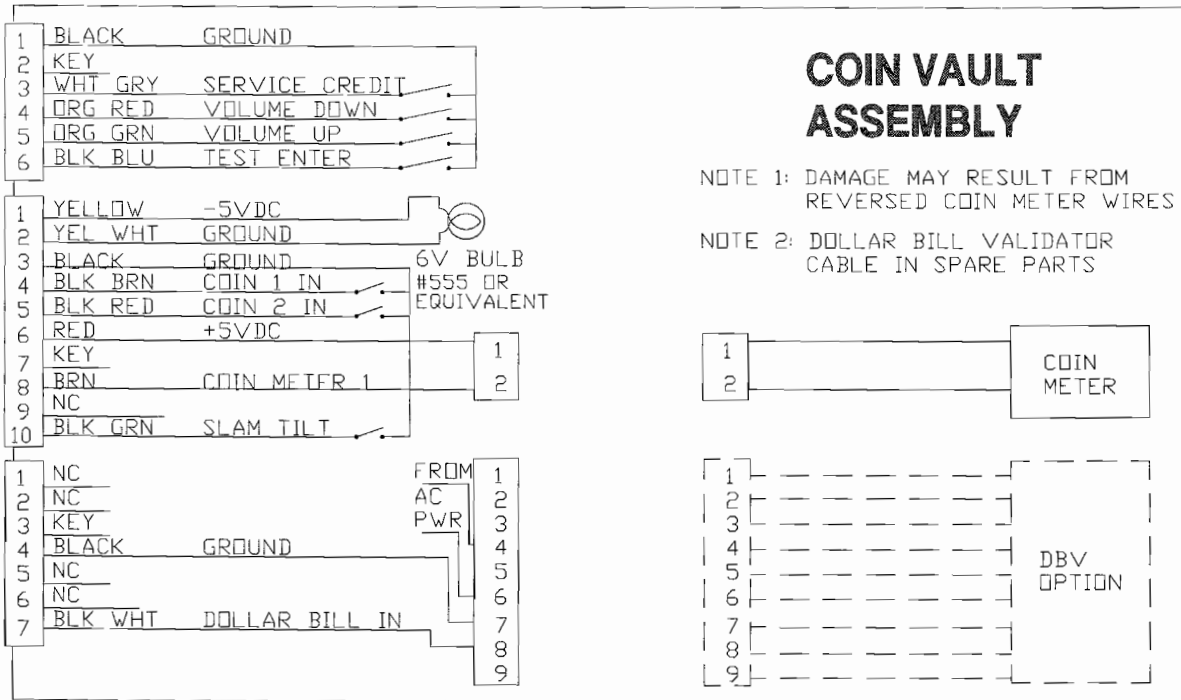

ELECTRONIC COIN ACCEPTOR WIRING

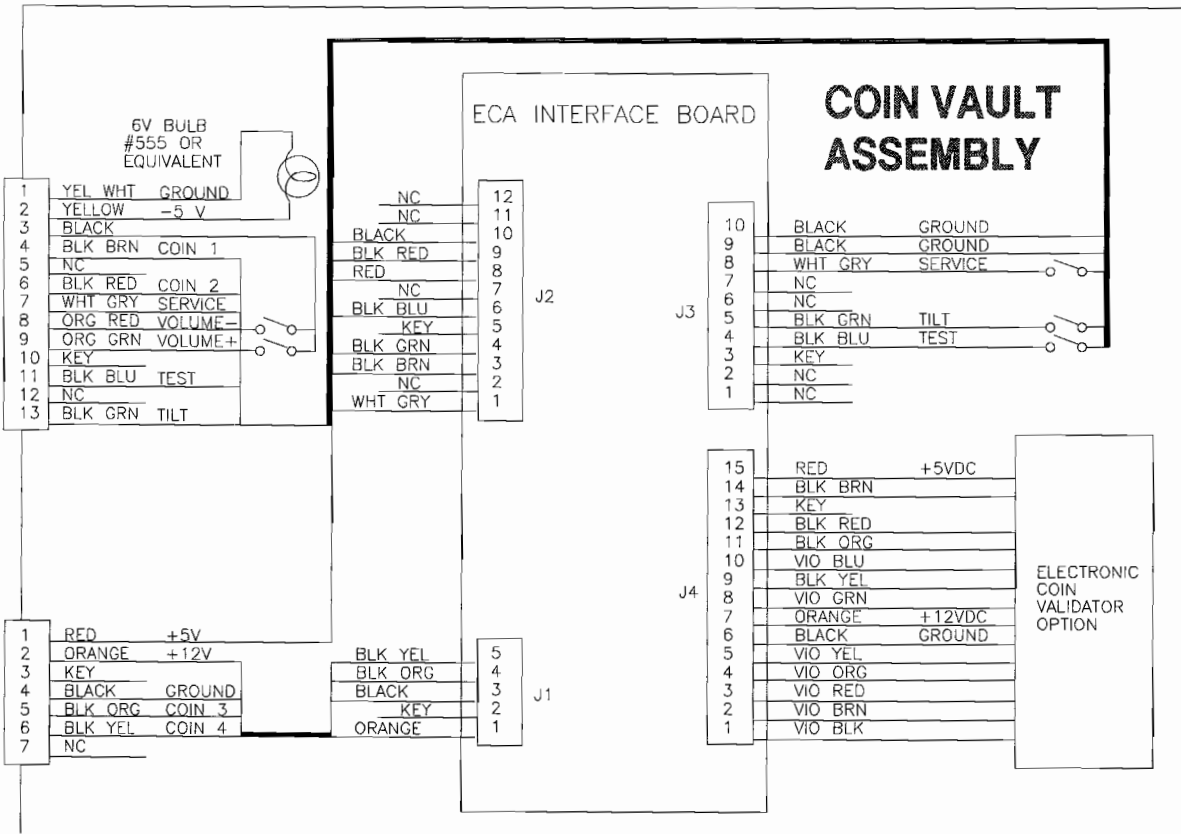

CPU BOARD INDICATOR AND SWITCH LOCATIONS

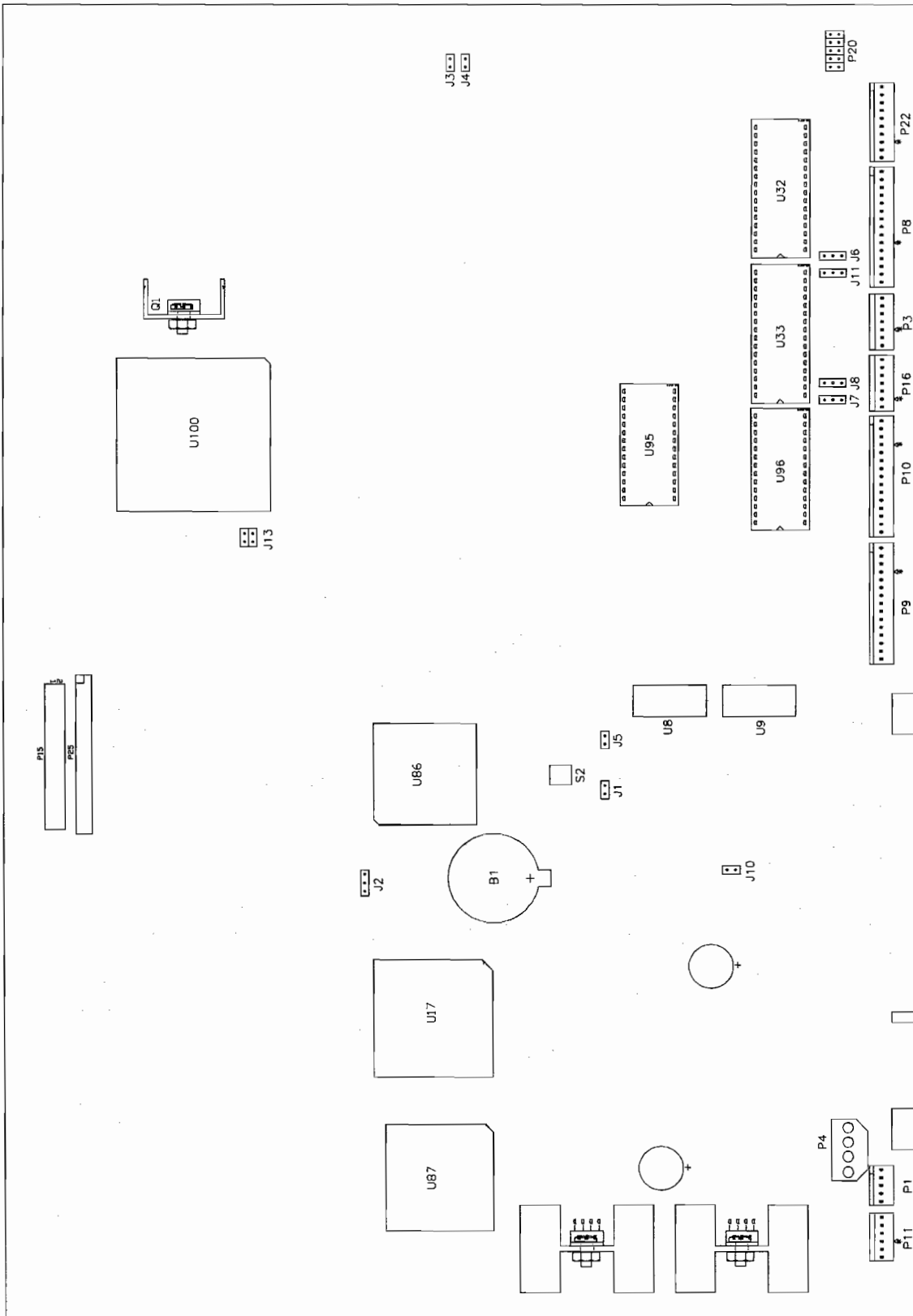

CPU BOARD JUMPER STATUS CHART

| DESIGNATION | LOCATION | FUNCTION | MEANING | SETTING | DEFAULT |
|-----------------|--------------------------------|--------------------------------------|---|------------------------------|---------|
| J1 (NOTE 1) | MIDDLE CENTER NEAR B1 & S2 | REMOTE GAME RESET | RESERVED FOR FUTURE DEVELOPMENT | OPEN | ■ |
| | | | | 1 & 2 | |
| J2 (NOTE 1) | MIDDLE CENTER NEAR B1 & U86 | FUTURE USE ONLY | RESERVED FOR FUTURE DEVELOPMENT | OPEN | ■ |
| | | | | 1 & 2 | |
| J3 (NOTE 2) | LEFT CENTER NEAR C1 & C589 | WATCHDOG CIRCUIT ENABLE | FACTORY DEFAULT SOFTWARE FAIL SAFEGUARD | OPEN | ■ |
| | | | | 1 & 2 | |
| J4 (NOTE 1) | LEFT CENTER NEAR C11 & C240 | FUTURE USE ONLY | RESERVED FOR FUTURE DEVELOPMENT | OPEN | ■ |
| | | | | 1 & 2 | |
| J5 (NOTE 1) | MIDDLE CENTER NEAR D6 & U64 | FUTURE USE ONLY | RESERVED FOR FUTURE DEVELOPMENT | OPEN | ■ |
| | | | | 1 & 2 | |
| J6 (NOTE 3) | UPPER LEFT NEAR P8 & U32 | MAIN BOOT ROM SIZE AND TYPE | CONFIGURES U32 FOR 4 MEGABYTE BOOT ROM | OPEN | |
| | | | | 1 & 2 | |
| | | | | 2 & 3 | ■ |
| J7 (NOTE 3) | UPPER LEFT NEAR P10 & U33 | MAIN BOOT ROM SIZE AND TYPE | CONFIGURES U32 FOR 4 MEGABYTE BOOT ROM | OPEN | |
| | | | | 1 & 2 | ■ |
| | | | | 2 & 3 | |
| J8 (NOTE 3) | UPPER LEFT NEAR P16 & U33 | MAIN BOOT ROM SIZE AND TYPE | CONFIGURES U32 FOR 4 MEGABYTE BOOT ROM | OPEN | |
| | | | | 1 & 2 | ■ |
| | | | | 2 & 3 | |
| J9 (NOTE 4) | NONE | NOT USED | NONE | NONE | --- |
| J10 (NOTE 5) | UPPER RIGHT NEAR C640 & U14 | VIDEO SYNC SIGNAL | NEGATIVE VIDEO SYNC POLARITY | OPEN | ■ |
| | | | | 1 & 2 | |
| J11 (NOTE 3) | UPPER LEFT NEAR P3 & U33 | EXPANSION ROM SIZE AND TYPE | RESERVED FOR FUTURE DEVELOPMENT | OPEN | |
| | | | | 1 & 2 | ■ |
| | | | | 2 & 3 | |
| J12 (NOTE 4) | NONE | NOT USED | NONE | NONE | --- |
| J13 (NOTE 1) | LOWER LEFT NEAR U25 & U100 | JTAG PROCESSOR FEATURES | RESERVED FOR FUTURE DEVELOPMENT | OPEN | ■ |
| | | | | 1 & 2 | |
| | | | | 3 & 4 | |
| P20 | UPPER LEFT NEAR P22 & U32 | CPU BOARD PRODUCTION TEST JACK | USED FOR FACTORY TEST ONLY | DO NOT USE JUMPER S | --- |

NOTES:

1. Jumper is not required for any version of this CPU Board. Connections are made with copper on board.
2. Jumper is not required for versions 01-05 of this CPU Board. Jump pins 1 & 2 for version 06 and up.
3. Jumper changes for some sizes and types of ROM. Jumper positions shown in ROM kit instructions.
4. Jumper is not required for any version of this CPU Board. These pins are not present on CPU Board.
5. Jumper is not required for production video monitors. Jump pins 1 & 2 for positive sync type monitors.

CPU SWITCHES

| DESIGNATION | LOCATION | FUNCTION | POSITIONS | STATE | MEANING |
|-------------|---------------------------------|------------------------|-----------|-------|----------------------|
| S2 | MIDDLE CENTER NEAR U41 & B1 | WARM START RESET | 1 | OFF | NORMAL OPERATION |
| | | | | ON | FORCED CPU RESET |
| U8 | MIDDLE CENTER NEAR U20 & U94 | SOFTWARE GAME MODES | 8 | OFF | STANDARD SETTINGS |
| | | | | ON | CUSTOM SETTINGS |
| U9 | MIDDLE CENTER NEAR U20 & U94 | SOFTWARE GAME MODES | 8 | OFF | STANDARD SETTINGS |
| | | | | ON | CUSTOM SETTINGS |

NOTES:

1. Use S2 during testing or troubleshooting. This restart is faster than switching power off and on again.

CPU BOARD LED INDICATOR STATUS CHART

| DESIGNATION | LOCATION | FUNCTION | COLOR | STATE | MEANING |
|----------------|---------------------------------|------------------------|--------|----------|------------------------|
| LED 1 (HDD) | BOTTOM CENTER NEAR P15 & P25 | HARD DISK ACTIVITY | RED | OFF | NOT IN USE |
| | | | | ON | LOCKED UP (NOTE 1) |
| | | | | BLINKING | NORMAL OPERATION |
| LED 2 | MIDDLE CENTER NEAR B1 & S2 | CPU RESET INDICATOR | RED | OFF | NORMAL OPERATION |
| | | | | ON | PROCESSOR RESET |
| | | | | BLINKING | RESET LOOP (NOTE 2) |
| LED 3 | MIDDLE CENTER NEAR B1 & S2 | INDICATOR | YELLOW | OFF | NORMAL OPERATION |
| | | | | ON | PROCESSOR RESET |
| | | | | BLINKING | RESET LOOP (NOTE 3) |

NOTES:

1. Hard Disk Drive LED 1 only active in short bursts during game. May appear continuous during start up. If this LED is always on, there may be a fault that has caused the drive to be in a locked up condition.
2. LED 2 monitors a part of the ROM boot instruction set. Must be active only during power on or reset.
3. LED 3 monitors a part of the ROM boot instruction set. Must be active only during power on or reset.

CPU BOARD LED INDICATOR STATUS CHART (continued)

| DESIGNATION | LOCATION | FUNCTION | COLOR | STATE | MEANING |
|-----------------|--------------------------------|-------------------------|--------|----------|--------------------------------|
| LED 4 | MIDDLE CENTER NEAR B1 & S2 | INDICATOR | GREEN | OFF | NO BOOT ROM (NOTE 4) |
| | | | | ON | PROCESSOR RESET |
| | | | | BLINKING | NORMAL OPERATION |
| LED 5 (IOA) | UPPER CENTER NEAR U8 & U9 | CONTROL ACTIVITY | GREEN | OFF | NO I/O FUNCTIONS PRESENT |
| | | | | ON | NORMAL OPERATION |
| | | | | BLINKING | I/O ASIC FAULT (NOTE 5) |
| LED 6 (SND) | UPPER LEFT NEAR U95 & U101 | SOUND ACTIVITY | YELLOW | OFF | NO AUDIO ROM (NOTE 6) |
| | | | | ON | READING ROM INSTRUCTIONS |
| | | | | BLINKING | NORMAL OPERATION |
| LED 7 (+12V) | UPPER RIGHT NEAR C409 & L1 | +12V POWER INDICATOR | RED | OFF | NO POWER |
| | | | | ON | NORMAL OPERATION |
| | | | | BLINKING | POWER FAULT (NOTE 7) |
| LED 8 (-5V) | UPPER RIGHT NEAR L2 & P4 | -5V POWER INDICATOR | RED | OFF | NO POWER |
| | | | | ON | NORMAL OPERATION |
| | | | | BLINKING | POWER FAULT (NOTE 8) |
| LED 9 (+5V) | UPPER RIGHT NEAR P14 & R571 | +5V POWER INDICATOR | RED | OFF | NO POWER |
| | | | | ON | NORMAL OPERATION |
| | | | | BLINKING | POWER FAULT (NOTE 9) |

NOTES:

4. Boot ROM is only active in short bursts during start up. May appear very irregular during circuit reset.
5. I/O ASIC is only active in short bursts during start up. Must be on continuously during game play.
6. Sound is only active in short bursts during start up. Must be on continuously during game play.
7. LED 7 monitors a regulated power supply voltage source. Must be on continuously at all times.
8. LED 8 monitors a regulated power supply voltage source. Must be on continuously at all times.
9. LED 9 monitors a regulated power supply voltage source. Must be on continuously at all times.

WHEEL DRIVER ASSEMBLY INDICATOR LOCATIONS

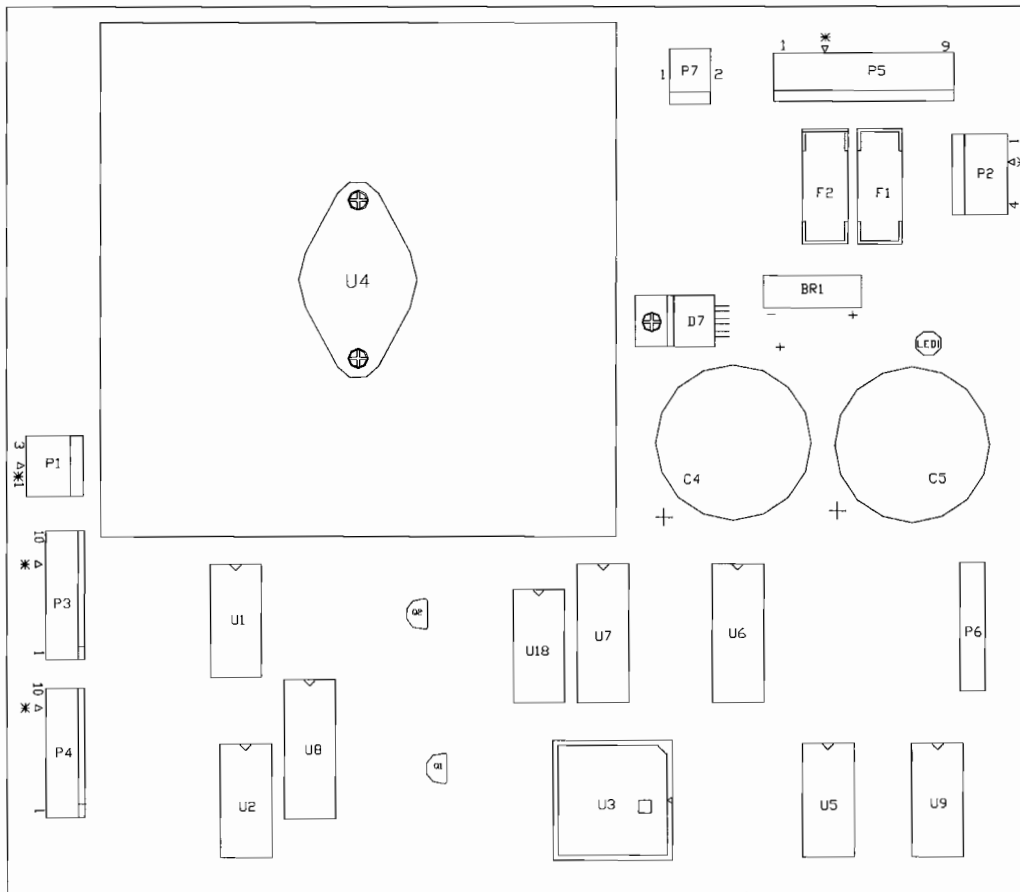

WHEEL DRIVER BOARD LED INDICATOR STATUS CHART

| DESIGNATION | LOCATION | FUNCTION | COLOR | STATE | MEANING |
|-------------|----------|---------------------------------|-------|----------|----------------------|
| LED 1 | NEAR C5 | DIGITAL POWER INDICATOR (+5VDC) | RED | OFF | NO POWER |
| | | | | ON | NORMAL OPERATION |
| | | | | BLINKING | POWER FAULT (NOTE 1) |

NOTE: LED1 monitors a regulated power supply voltage source. It must be on continuously.

ADC/AUX WIDGET BOARD INDICATOR LOCATIONS

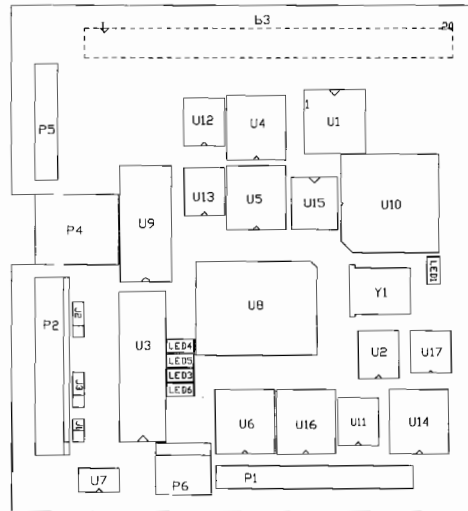

ADC/AUX WIDGET BOARD LED INDICATOR STATUS CHART

| DESIGNATION | LOCATION | FUNCTION | COLOR | STATE | MEANING |
|----------------|--------------------------------|----------------------|--------|----------|--------------------------------|
| LED 1 (IOA) | MIDDLE CENTER NEAR Y1 & R28 | CONTROL ACTIVITY | RED | OFF | NO I/O FUNCTIONS PRESENT |
| | | | | ON | NORMAL OPERATION |
| | | | | BLINKING | INTERMITTENT OPERATION |
| LED 3 (RX) | LOWER LEFT NEAR R67 & U3 | LINK RECEIVE | YELLOW | OFF | NOT IN USE (NO GAME LINK) |
| | | | | ON | RECEIVING DATA |
| | | | | BLINKING | NORMAL OPERATION |
| LED 4 (LNK) | LOWER LEFT NEAR R67 & U3 | LINK VERIFY PULSE | GREEN | OFF | NOT IN USE (NO GAME LINK) |
| | | | | ON | NORMAL OPERATION |
| | | | | BLINKING | LINK FAULT |
| LED 5 (SEL) | LOWER LEFT NEAR R67 & U3 | CPU LINK ACTIVITY | RED | OFF | NOT IN USE (NO GAME LINK) |
| | | | | ON | CPU LINK ACTIVITY |
| | | | | BLINKING | NORMAL OPERATION |
| LED 6 (TX) | LOWER LEFT NEAR R67 & U3 | LINK TRANSMIT | RED | OFF | NOT IN USE (NO GAME LINK) |
| | | | | ON | SENDING DATA |
| | | | | BLINKING | NORMAL OPERATION |

VAPOR TRX™

SECTION FOUR

TROUBLESHOOTING



This game uses complex electronic components that are very **SENSITIVE** to static electricity. Observe and follow these precautions prior to handling any of the game electronics:

1. Turn **OFF** the A.C. power to the game prior to servicing the electronics.
2. Discharge any static electricity build up in your body by touching the safety ground stud of the power supply chassis while the line cord is connected to a properly grounded outlet. Do this **BEFORE** touching or handling the electronic assemblies.
3. Store the electronic assemblies in an anti-static area. Use anti-static bags to store or transport the game CPU Board Assembly.
4. **DO NOT** remove or connect any electronic assemblies when the cabinet power is **ON**. This can damage the electronic assemblies and will void the warranty.
5. Always replace ground wires, shields, safety covers, etc. when maintenance or service is completed. Tighten all ground and mounting screws firmly when replacing.

GAME DOES NOT START

1. Game appears completely non-functional; no audio, no illumination, no video display.

- A: Plug in the line cord. Turn the Power Switch ON (center left rear corner of the game cabinet).
- B: Turn OFF the game power. Unplug the A.C. line cord. Examine the power supply A.C. fuse. Set the power supply line voltage switch to agree with the local A.C. line voltage.
- C: Remove the line cord. Test the line cord, power plug and I.E.C. connector for breaks or damage. Verify continuity of each wire in the cord. Fully seat connector in the supply receptacle.
- D: Unlock and open the rear door. Lift the door up and out, remove it and set it aside. Seat the cabinet wiring harness connectors fully in their corresponding A.C. and D.C. Power Supply Assembly connectors (refer to Power Wiring Diagram, Section Three).
- E: Examine the D.C. fuses on the electronic equipment shelf. If any fuse is faulty, replace it with an identical fuse from the spare parts bag. Replace the spare fuse when repairs are complete.
- F: Fully seat the A.C. plug in the outlet. Check the A.C. line voltage. Turn the game power ON. Check the D.C. wiring harness and connectors if the fuse opens the circuit again.

2: Video game appears non-functional, but coin door price indicator is illuminated.

- A: Unlock and hold the cabinet rear door partially open. Inspect the CPU board assembly under low light level conditions. The light emitting diodes glow if there is voltage in the processor circuits. This does not mean that voltages or signals are as they should be, but does indicate that the CPU board is receiving some D.C. power from the power supply.
- B: Turn OFF the game power. Remove the cabinet rear door. Inspect the CPU board assembly. Seat the JAMMA wire harness connector fully onto its mating board connector. Check all other wiring harness connectors in the same way.



CAUTION: DO NOT REMOVE OR INSTALL ANY CONNECTOR WHILE POWER IS TURNED ON! THIS CAN DAMAGE THE GAME CPU BOARD ASSEMBLY AND WILL VOID THE WARRANTY!

- C: Check the game CPU DIP switch settings. Refer to the Switch Configuration Chart (Section One) for variables and default settings.
- D: Turn ON the game power. Using the 20 Volt D.C. setting on a digital voltmeter, measure D.C. voltages at the power connector pins. Adjust the +5V source only if necessary. Refer to the Cabinet Wiring Diagram (Section Three) for specific wiring information and voltage limits.
- E: Using the 2 Volt A.C. setting on a digital voltmeter, measure the same D.C. voltages as above. Any reading here indicates unstable supply voltages and possible ripple or noise.
- F: Verify that the game runs and completes the Power On Test sequence without any errors. Note errors and/or failures during these tests.
- G: Enter the game Menu System by pressing and holding the TEST MODE switch inside the coin door. From the SELF TEST menu, choose the MONITOR TESTS (refer to Section One for additional details). Use this set of tests to check the operation of each screen in the game.

GAME CANNOT BE PLAYED

1. Game will not accept currency or tokens and cannot be started. Audio and video are present.

- A: Unlock and open the cash door. Empty the cash box. Inspect the revenue for any counterfeit currency. Check the vault and remove any items that block the path from the mechanism.
- B: Unlock and open the coin door. Check each mechanism by hand to ensure proper mounting. Remove the mechanism and clear the currency path. Reinstall the mechanism and latch it.
- C: Close the mechanism doors and check leveling. Repair or replace the coin door if it is bent or damaged. Adjust the cabinet leg levelers if necessary to keep mechanisms vertical.
- D: Enter the game Menu System by pressing and holding the TEST MODE switch inside the coin door. From the SELF TEST menu, choose COIN OPTIONS (refer to Section One for additional details). Use these tests to confirm the pricing and setup of each mechanism used in the game.
- E: Enter the game Menu System by pressing and holding the TEST MODE switch inside the coin door. From the SELF TEST menu, choose the CONTROL TESTS (refer to Section One for additional details). Use this set of tests to check the operation of each coin or bill mechanism.

2. Game accepts currency or tokens, but does not start. Audio and video are present.

- A: Unlock and open the coin door. Check each mechanism by hand to ensure proper mounting. Verify that each of the release latches is in the closed and locked position. Test known good and bad coins to see if the mechanism accepts and rejects currency correctly.
- B: Check the hinges, latches, and switch contacts for obstructions or loose parts.
- C: Inspect to see if the external coin door indicators (pricing, flashing arrows, etc.) are illuminated. Check connectors and cables for wiring continuity from CPU Board to the coin mechanisms.
- D: Enter the game Menu System by pressing and holding the TEST MODE switch inside the coin door. From the SELF TEST menu, choose COIN OPTIONS (refer to Section One for additional details). Use these tests to confirm the pricing and setup of each mechanism used in the game.
- E: Check for continuity in each of the suspect switch connections (Common to Normally Open or Common to Normally Closed). Replace faulty switches (bent levers, broken actuators, etc.).
- F: Verify that each coin mechanism is operating properly by placing it in a known good unit.

3. Game does not accept paper currency. Coin mechanism operates properly.

- A: Dollar bill validators or other currency acceptors may be installed in games manufactured with an additional wiring connector (DBV ready). Some units may require modification to fit the coin door; the recommended installation procedure is elsewhere in this manual (refer to Servicing in Section One). The Wiring Diagrams (Section Three) show the DBV power and signal connections.
- B: Ensure that the game recognizes the electronic signals from the Dollar Bill Validator. Enter the game Menu System by pressing and holding the TEST MODE switch inside the coin door. From the SELF TEST menu, choose COIN OPTIONS (refer to Section One for additional details). Consult the manufacturer's information the validator assembly needs changes.

4. Game accepts currency or tokens, but number of credits per coin or bill is incorrect.

- A: Enter the game Menu System by pressing and holding the TEST MODE switch inside the coin door. From the SELF TEST menu, choose COIN OPTIONS and MECH SETUP (refer to Section One for additional details). Use these tests to confirm the operation of each coin switch.
- B: From the GAME ADJUSTMENTS menu, choose COIN OPTIONS to verify units and credits.
- C: Check that the cabinet wiring is correct for this game. Ensure that the coin meter and coin switches are properly connected to the control input wires from the JAMMA connector and other CPU wiring. Refer to the Power Wiring Diagram (Section Three) for specific wiring information.

COIN SWITCH AND METER WIRING

FACTORY STANDARD

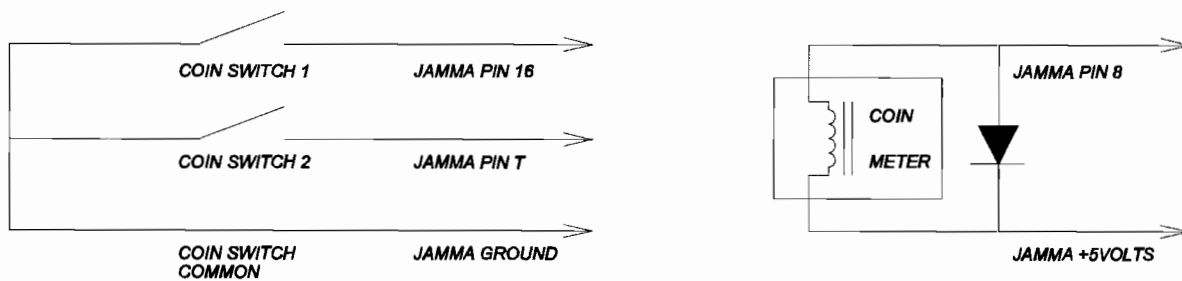

OPTIONAL WIRING

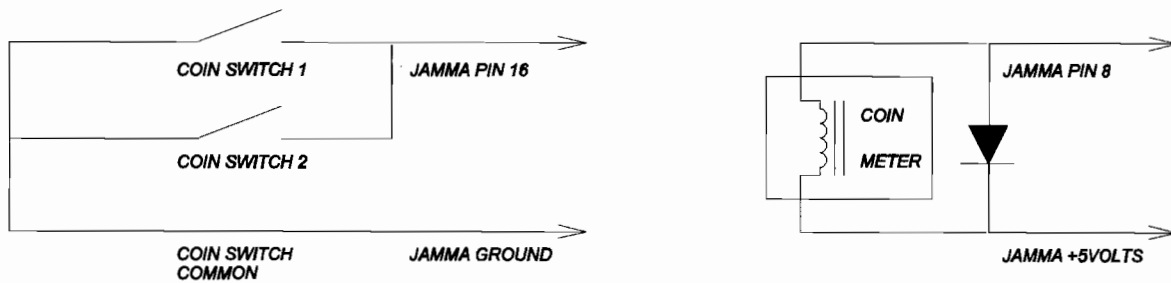

INCORRECT WIRING

A connection between JAMMA coin input pins will cause twice the desired credits for each coin inserted. A coin meter with a defective or missing diode may eventually damage driver circuits on the CPU Board.

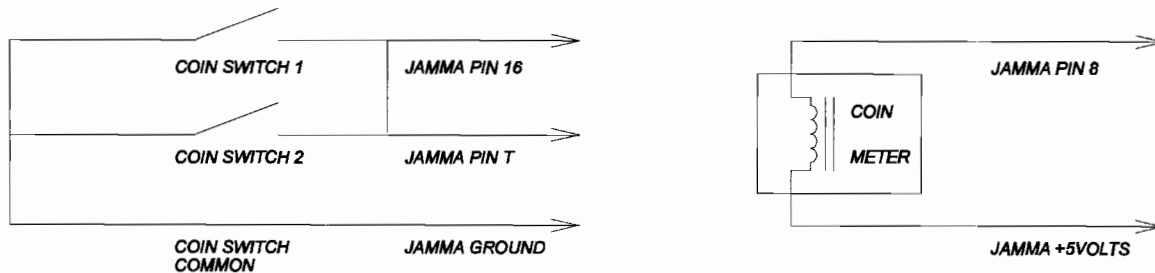

LINKING PROBLEMS

1. Cannot connect games together. Games have linking cables.

- A: Interconnection among games requires a linking kit. Basic Linking Kits contain a crossover coupler, brackets, and spacers necessary to link two cabinets. Each kit connects two games (one pair).
- B: A local network needs a concentrator hub. Hub Link Kits permit up to eight game connections. A complete game array requires basic kit brackets and spacers.
- C: This linking system uses 10Base-T ETHERNET-type Category 5 twisted-pair communications wiring for the game data exchanges. *Do not substitute other cables or communication wiring without factory authorization.*

2. Game functions correctly by itself, but does not recognize other players in linking operation.

- A: Note and record any error messages that occur during self-test. If the message "BAD GAME OPTIONS: TWO [COLOR] STATIONS" appears on screen, two or more of the linked cabinets have the same color vehicles. Open the coin door. Press and hold the TEST MODE switch to enter the menu system. On the GAME OPTIONS menu, check that the vehicle color is different for each cabinet. A unique color is required for each vehicle in a linked race.
- B: From the SELF TESTS menu, choose NETWORK TESTS. These tests verify some of the communication functions in this game. Verify that power is on if a Hub is in use.
- C: Inspect the hub indicator lights. Each active port should have an illuminated indicator. If a cable is connected and there is no indicator for that position, check for cable continuity from hub to game. Ensure that no loose parts or wires are caught in the hinges, doors, or under the cabinet.
- D: Unlock and open the rear door. Verify that the linking cable is connected to the CPU Board. Compare the CPU Board LED Indicator Status Chart (refer to Section Three) against the CPU network indicators, particularly LED 6 (Receiving), LED 10 (Linking), and LED 12 (Transmitting).
- E: Verify that each linking cable is operating properly by placing it in a known good unit.

3. Some games in a group link properly while others do not.

- A: All linked cabinets require the same software version. Unlock the coin door and press the TEST MODE button. The software version has two dates at the bottom of the menu screen: GUTS and MAIN. It does not matter which revision level is installed, only that all games must be the same.
- B: If the message "VERSION INCOMPATIBLE WITH [COLOR] STATION" appears on screen, check the software versions of each game. All versions must be identical for linked games to operate properly.
- C: If the message "BAD GAME OPTIONS: TWO [COLOR] STATIONS" appears on screen, two or more of the linked cabinets have the same color vehicles. Go to GAME OPTIONS and set each GAME ID to a unique value. Restart all linked games after resetting the GAME OPTIONS.
- D: Coupled games require crossover connections. Standard couplers appear identical to the devices supplied with Basic Link Kits, but they do not have the internal crossover. Verify that each linking crossover coupler is operating properly by placing it in a known good link between two games.

- E: Networked games do not require a crossover (the hub has an electronic crossover function). Ensure that the switches on the hub are set correctly according to the Hub Link Kit instructions. Inspect the hub indicator lights for link activity. Consult manufacturer's literature for diagnostics.
- F: *Do not use an additional crossover connector and another cable to extend a Basic or a Hub Link connection.* Two crossovers will cancel out and cause the same problem as no link crossover. The transmit and receive line pairs must interconnect in order for data to be exchanged.
- G: Separate communications wiring from other wiring, especially line cords. If unavoidable, cross at right angles to limit noise pickup. *Do not bundle network cables with any other wires.*

PLAYER CONTROL PROBLEMS

1. Player controls are intermittent or completely non-functional. Game starts normally.

- A: Turn off power for one minute and turn the game on again. The automatic game POWER ON TESTS routine will test electronics and controls. The screen will report any errors on completion. *Do not touch the steering wheel or pedals during this calibration routine unless directed to do so.*
- B: Unlock and open the coin door. Enter the game Menu System by pressing and holding the TEST MODE switch inside the coin door. From the SELF TEST menu, choose the CONTROLS TEST (refer to Section One for additional details). Use these tests to confirm the operation of each switch and light used in the game.
- C: Check that the cabinet wiring is correct for this game. Ensure that the controls are properly connected to the control input wires from the JAMMA connector. Refer to the Power Wiring Diagram (Section Three) for specific wiring information.
- D: Ensure that no loose parts or wires are caught in the hinges, latches, or switch contacts. Check continuity in each of the switch connections (Common to Normally Open or Common to Normally Closed). Verify that the control is operating properly by placing in a known good unit.
- E: Verify that dashboard switch light bulbs are the type specified in the parts listing. Other bulbs will light, but the higher heat level can cause the switches to bind or stick after hours of operation.

2: Steering control is partly functional, but video is present and game appears to start normally.

- A: Turn off power for one minute and turn the game on again. The automatic game POWER ON TESTS routine will test electronics and controls. The screen will report any errors on completion. *Do not touch the steering control or pedals during this calibration routine unless directed to do so.*
- B: With the game power ON, check the flow of air from each of the fans at the rear of the cabinet.
- C: Unlock and hold the cabinet rear door partially open. Inspect the Motor Board Assembly under low light level conditions. A glow will be seen from the Light Emitting Diodes if there is voltage in the motor driver circuits. This does not mean that voltages or signals are as they should be, but it does indicate that the Motor Board is receiving some A.C. power from the transformer.
- D: Turn OFF the game power. Adjust the seat to its maximum rear position. Open the dashboard. Support the steering control and remove the outer mounting screws. Remove the support and gently lower the control to the floor. Inspect for faulty belts, bearings, couplings, etc.



WARNING: Motor Driver Board heatsink, power resistors, and other components may be very HOT. The D.C. motor in the Steering Wheel Assembly also may be HOT.

- E: Examine the fuses and cables on the Motor Driver Board. If any fuse is faulty, replace it with an identical fuse from the spare parts bag. Replace the spare fuse after completing repairs.
- F: Using a digital voltmeter, verify that D.C. voltage present between the heatsink and ground is half of the full supply voltage (approx. -27V). Check the +15V, -15V, +10V and +5V sources. Refer to the Power Wiring Diagram (Section Three) for specific wiring information and voltage limits.
- G: Using the 2 Volt A.C. setting on a digital voltmeter, measure the same D.C. voltages as above. Any reading here indicates that the supply voltages are unstable and may contain ripple or noise.
- H: Verify proper operation of game Motor Board Assembly by placing it in a known good game.

AUDIO PROBLEMS

1: Audio is non-functional, but video is present and game appears to operate normally.

- A: Unlock and open the coin door. Enter the game Menu System by pressing and holding the TEST MODE switch inside the coin door. From the SELF TEST menu, choose ADJUST VOLUME (refer to Section One for additional details). Verify that the attract and game volume levels are set above zero. Increase the volume if necessary to make the game very loud.
- B: Follow the on-screen instructions to return to the first menu. From the SELF TEST menu, choose SOUND TESTS. Use these tests to confirm the operation of each speaker in the cabinet.
- C: Turn OFF the game power. Inspect each speaker and its wiring harness. Ensure that no loose parts or wires are caught in speaker cones, terminals, mounting screws, or stuck to the magnets. Do not use excess force when removing or tightening mounting screws threaded into plastic.
- D: Verify correct cabinet wiring for this game. Ensure that the speakers are properly connected to the audio output wires from the speaker connector. Verify speaker continuity. Refer to the Power Wiring Diagram (Section Three) for specific wiring information.
- E: Turn ON the game power. Using the 20 Volt D.C. setting on a digital voltmeter, measure D.C. voltages present at the Power connectors. Verify the +12V source at the Audio board. Refer to the Power Wiring Diagram (Section Three) for specific wiring information and voltage limits.
- F: Using the 2 Volt A.C. setting on a digital voltmeter, measure the same D.C. voltages as above. Any reading here indicates that the supply voltages are unstable and may contain ripple or noise.
- G: Verify proper operation of suspect audio and CPU boards by placing in a known good game.

2: The audio is distorted, muffled or missing frequencies. There may be a constant low hum.

- A: Unlock and open the coin door. Enter the game Menu System by pressing and holding the TEST MODE switch inside the coin door. From the SELF TEST menu, choose SOUND TESTS. These tests will verify some of the functions of the audio circuits in this game.
- B: Turn OFF the game power. Remove the grills and check the speakers. This game uses four speakers and one woofer. Ensure that all small speakers are 8Ω FULL RANGE (100-10,000 Hz response) and rated for at least 15 WATTS. The 4Ω woofer must rate at least 25 WATTS.
- C: Check that the speaker wiring is not reversed at one of the speakers. Weak low frequencies and a thin or hollow sound quality are symptoms of incorrectly phased speakers. These conditions will not be detected by the SOUND TESTS, but will be audible during the ADJUST VOLUME music.

- D: Check that the cabinet wiring is correct for this game. Verify that the cabinet wiring provides separate wires (not a common return) for each speaker. Ensure that all cabinet ground wires are connected. Refer to the Power Wiring Diagram (Section Three) for specific wiring information.
- E: Using the 2 Volt A.C. setting on a digital voltmeter, measure voltages at the speaker terminals. Any reading here indicates that the supply voltages are unstable and may contain ripple or noise.
- F: Verify that each speaker is operating properly by placing in a known good unit.

VIDEO PROBLEMS

1. Monitor does not work, but there is sound and controls operate as expected.

- A: Unlock and open the rear door. Verify that A.C. Power is connected to the Video Monitor. Inspect the neck of the CRT under low light level conditions. A glow will be seen near the CRT base if there is voltage in the filament circuits. This does not mean that other voltages or signals are as they should be, but it does indicate that some of the monitor circuits are receiving power.
- B: Turn OFF the game power. Verify that the Video Signal and the Remote Adjustment Board connectors are fully seated on the Video Monitor Board Assembly. Check the other monitor connectors in the same way. ***Do not operate a monitor without a Remote Adjustment Board.***



WARNING: CRT and Video Monitor Board may store voltage after power is turned off.

- C: Examine the A.C. line fuse on the Video Monitor Board Assembly. If the fuse is faulty, replace it with an identical fuse of the proper voltage and current rating.
- D: Ensure that no loose parts or wires are caught on the chassis or the mounting brackets.
- E: Unlock and open the coin door. The monitor adjustment controls are mounted on the rear wall. Check that the brightness (intensity) and contrast have not been set to their minimum levels.
- F: Verify that the Video Monitor is operating correctly by placing it in a known good unit.

2: The Power On Tests will run, but the game does not appear. No audio is present.

- A: Note and record any error messages that occur during the Power On Test. Open the coin door. Press and hold the TEST MODE switch to enter the menu system. From the SELF TESTS menu, choose DISK TESTS. These tests will verify some of the game Hard Disk Drive functions.
- B: Turn OFF the game power. Unlock and remove the rear door. Inspect the CPU Board Assembly. Ensure that Hard Disk Drive Assembly ribbon cable and power connectors are fully seated into the mating connectors on the CPU Board. Verify that all disk drive mounting screws are installed.

CAUTION: DO NOT REMOVE OR INSTALL ANY CONNECTOR WHEN POWER IS TURNED ON. THIS WILL DAMAGE THE CPU BOARD OR HARD DISK DRIVE AND VOID THE WARRANTY.

- C: Check that the Hard Disk Drive Assembly is the correct part for this game. Each Hard Disk Drive is labeled with the assembly number and the software version. Refer to Parts (Section Two).
- D: Verify that the ROM instruction set is correct for this game. There is more than one ROM in a game set. Each ROM circuit is labeled with the assembly number and the software version.
- E: Verify that the CPU Board Assembly is correct for this game. Each CPU Board is marked with the manufacturer name, assembly number and the hardware version.

- F: Turn ON the game power. Using the 20 Volt D.C. setting on a digital voltmeter, measure D.C. voltages present at the drive power connector pins. Verify the +5V source if it is adjustable. Refer to the Power Wiring Diagram (Section Three) for specific wiring information and voltage limits.
- G: Using the 2 Volt A.C. setting on a digital voltmeter, measure the same D.C. voltages as above. Any reading indicates that the supply voltages are unstable and may contain ripple or noise.
- H: Compare CPU Board Light Emitting Diode states with the CPU Indicator Chart (Section Three). Press the CPU reset button (near the battery) and observe the start up sequence of the LEDs.

3. Monitor will not lock onto the signal and provide a stable picture, colors are missing, etc.

- A: Unlock the coin door. Adjust vertical and horizontal hold controls at the remote adjustment board.
- B: Check connectors and cables for wiring continuity from the CPU Board to the video monitor. Check connectors and cables for wiring continuity from the adjustment board to the video monitor.
- C: Ensure that the Video Monitor Assembly is correct for this game. Use of video monitors with different resolution will result in what appears to be horizontal tearing or complete loss of sync.
- D: Verify that the Video Monitor is operating correctly by placing it in a known good unit.

4: Game operates normally, but video picture wavers or rolls, has dark bars, uneven colors, etc.

- A: Check connectors and cables for wiring continuity from the CPU Board to the Video Monitor. Ensure that all the cabinet ground wires are connected, especially at the Video Monitor Chassis.
- B: Move the cabinet farther away from machines, appliances, other games, etc. Very strong electrical or magnetic fields are emitted from some equipment during normal operation.
- C: Verify that the Video Monitor is operating correctly by placing it in a known good unit.

MISCELLANEOUS

1: Marquee lamp is intermittent or non-functional. Game starts and plays normally.

- A: Open the marquee and remove the glass. Remove the fluorescent tube from its holders. Clean the tube. If the lamp has cracks or darkened ends, install a new one.
- B: Verify that the lamp and starter pins are making good connection with their socket contacts.
- C: Measure the Fluorescent Lamp Assembly A.C. voltages (Power Wiring Diagram, Section Three). Check wiring and connector continuity from the A.C. Power Chassis to the Lamp Assembly.
- D: Ensure that the fluorescent lamp ballast is rated for the local A.C. line voltage and frequency.
- E: Check for continuity of both fluorescent lamp filaments, the starter, and the ballast. One at a time, verify that the lamp, starter, and ballast operate by placing each in a known good unit.

2. Game operates normally, but fan is noticeably noisy.

- A: Check bottom and rear of cabinet for blocked air flow. Move game away from sources of heat.

B: Turn OFF the game power. Apply a high power vacuum cleaner to vent holes to remove dust.

C: Unlock and remove the rear door. Ensure that the fan is connected to wiring harness.

3. Error messages appear on the screen. The game does not start and there is no audio.

A: Check any assembly (RAM, ROM, Battery, etc.) identified in the error message.

B: Call your authorized distributor for help with unresolved screen messages.

WARNINGS & NOTICES

WARNING

USE OF NON-ATARI PARTS OR CIRCUIT MODIFICATIONS MAY CAUSE SERIOUS INJURY OR EQUIPMENT DAMAGE! USE ONLY ATARI AUTHORIZED PARTS.

* For safety and reliability, substitute parts and modifications are not recommended.

* Substitute parts or modifications may void FCC type acceptance.

* Use only authorized components and parts. Failure to do so will void warranty and may result in incorrect and/or unsafe operation.

* This game is protected by federal copyright, trademark and patent laws. Unauthorized modifications may be illegal under federal law. This also applies to ATARI logos, designs, publications and assemblies. Moreover, facsimiles of ATARI equipment (or any feature thereof) may be illegal under federal law, regardless of whether or not such facsimiles are manufactured with ATARI components.

NOTE: This equipment has been tested and found to comply with the limits for a Class A digital device, pursuant to Part 15 of the FCC Rules. These limits are designed to provide reasonable protection against harmful interference when the equipment is operated in a commercial environment. This equipment generated, uses and can radiate radio frequency energy and if not installed and used in accordance with the instruction manual, may cause harmful interference to radio communications. Operation of this equipment in a residential area is likely to cause harmful interference in which case the user will be required to correct the interference at his own expense.

When ATARI ships a game, it is in compliance with FCC regulations. Your label is proof. If the label is missing or damaged, legal repercussions to the owner or distributor of the game may result. If your game does not contain an FCC label, call ATARI immediately.

WARNING

Plug this game into a properly grounded outlet to prevent shock hazards and assure proper game operation. Do not use a cheater plug to defeat the power cord's grounding pin. Do not cut off the ground pin.

WARNING

A very small portion of the population has a condition which may cause them to experience epileptic seizures or have momentary loss of consciousness when viewing certain kinds of flashing lights or patterns that are present in our daily environment. These persons may experience seizures while watching some kinds of television pictures or playing certain video games. People who have not had any previous seizures may nonetheless have an undetected epileptic condition.

If you or anyone in your family has experienced symptoms linked to an epileptic condition (e.g. seizures or loss of awareness), immediately consult your physician before using any video games.

We recommend that parents observe their children while they play video games. If you or your child experience the following symptoms: dizziness, altered vision, eye or muscle twitching, involuntary movements, loss of awareness, disorientation, or convulsions, DISCONTINUE USE IMMEDIATELY and consult your physician.

NOTICE

Information in this manual is subject to change without notice. ATARI reserves the right to make improvements in equipment function, design, or components as progress in engineering or manufacturing methods may warrant.

NOTICE

No part of this publication may be reproduced by any mechanical, photographic, or electronic process, or in the form of a phonographic recording, nor may be transmitted, or otherwise copied for public or private use, without permission from the publisher.

FOR SERVICE: CALL YOUR AUTHORIZED ATARI DISTRIBUTOR.