



Trade Marks of Taito
America Corporation

Wild Western



"WILD WESTERN"™ UPRIGHT

TABLE OF CONTENTS

1. "WILD WESTERN"™ UPRIGHT GAME SET-UPPage 2	3. ILLUSTRATIONS AND PART LISTS
A. Introduction2	Figure 14 Cabinet Assembly Upright Rear View16
B. Game Inspection2	Figure 15 Revolving Control Assembly18
C. Game Installation2	Figure 16 Filter Board20
D. Dip Switch and Volume Control Settings2	Figure 17 Power Supply21
2. MAINTENANCE3	Figure 18 ROM Board24
A. Cleaning3	Figure 19 CPU Board26
B. Fuse Replacement3	Figure 20 Video Board28
C. Video Monitor Removal3	Figure 21 Game Board30
D. Video Monitor Adjustments (Separate Manual)4	Figure 22 Power Supply Schematic 1 of 133
E. Cover Glass Removal4	Figure 23 ROM PC Board Schematic 1 of 134
F. Printed Circuit Board Replacement4	Figure 24 CPU PC Board Schematic 1 of 335
3. ILLUSTRATIONS AND PART LISTS	Figure 25 CPU PC Board Schematic 2 of 336
Figure 1 Option Switches3	Figure 25 CPU PC Board Schematic 3 of 337
Figure 2 Volume Control Locations3	Figure 26 Video PC Board Schematic 1 of 538
Figure 3 Fuse Replacement3	Figure 27 Video PC Board Schematic 2 of 539
Figure 4 Video Monitor Removal3	Figure 28 Video PC Board Schematic 3 of 540
Figure 5 Cover Glass Removal4	Figure 30 Video PC Board Schematic 4 of 541
Figure 6 Printed Circuit Board Replacement4	Figure 31 Video PC Board Schematic 5 of 542
Figure 7 Incandescent Panel5	Figure 32 Game PC Board Schematic 1 of 743
Figure 8 8-Way Joystick6	Figure 32 Game PC Board Schematic 2 of 744
Figure 9 Control Panel7	Figure 34 Game PC Board Schematic 3 of 745
Figure 10 Door Assembly8	Figure 35 Game PC Board Schematic 4 of 746
Figure 11 Coin Door10	Figure 36 Game PC Board Schematic 5 of 747
Figure 12 Coin Door12	Figure 37 Game PC Board Schematic 6 of 748
Figure 13 Cabinet Assembly Upright Front View14	Figure 38 Game PC Board Schematic 7 of 749
	Figure 39 Wiring Diagram50

"WILD WESTERN"™ UPRIGHT

1. GAME SET-UP

A. INTRODUCTION

"WILD WESTERN"™ Taito America Corporation's 'WILD WESTERN' game is a journey back in time to the Wild West. You will mount your fiery steed in pursuit of a gang of bandits and feel like a real western hero when all the bandits are shot down and the locomotive safely passes through the desert.

The horses speed and direction is controlled by the 8-Way Joystick. Directional gunfire is controlled by the Revolving Control hitting the Button the player fires at the runaway bandits. The Bandits gunfire, running into cacti, rocks, or the train is fatal to the player.

When a Bandit hops on the train, the player must also climb aboard in order to shoot him. Getting aboard the train requires skill and timing as he must run parallel with the train at a safe distance and push the button to get aboard. The same is true when the player returns to his horse, he must wait for his horse to run alongside the train and time his jump in order to remount his horse.

Riding the train too long is also dangerous because the player must watch for outstretched waterpipes when passing by watertanks. The player must push the button to duck under the waterpipes or be knocked from the train.

The Player gets a chance to improve his aim in the bonus frame hitting the coin tossed into the air by his horse. Double the Bonus for a hit, or the horse laughs when missed.

The game ends when the player has lost all of his sheriffs or when 3 bandits have hopped aboard the train.

An additional sheriff is added for scoring 30,000 points (adjustable).

B. GAME INSPECTION

TAITO AMERICA'S CORPORATION'S "WILD WESTERN"™ upright game is ready to play when received. However, careful inspection is necessary to insure your game is in perfect condition. Please verify the following before turning the game on.

- * Examine external parts for chips, dents, or broken parts.
- * Open the service door and examine the following:
 - * Plug-in connectors to make sure they are firmly seated.
 - * Speaker
 - * Player Controls
 - * Printed Circuit Boards making sure there is no damage to the components.
 - * Check for loose foreign objects, especially metal objects which may cause electrical problems.
 - * Fuses, making sure they are firmly in the holders.
 - * Coin Mechanisms

The Video Monitor is properly adjusted before shipping. If there are any adjustments necessary refer to our Video Monitor Manual (72-00020-001).

If problems occur or technical assistance is required, contact our Customer Service Department HOT LINE Toll Free 800-323-0666 (except Illinois). Illinois phone 312 981-1000 X215.

POWER REQUIREMENTS

TAITO AMERICA CORPORATION'S "WILD WESTERN"™ upright game is shipped ready for operation at 120VAC, 60Hz with a power consumption of approximately 250 Watts.

CAUTION

For safe operation it is recommended the cabinet be grounded. This game is equipped with a three conductor power cable. The third conductor is the ground conductor and when the cable is plugged into an appropriate receptable, the game is grounded. The offset pin on the power cable's three-prong connector is the ground connection.

LOCATION SPACE REQUIREMENTS

Depth - 35" (87.5cm)
 Width - 24" (61cm)
 Height - 68" (171cm)
 Weight - 300 lbs.
 (Packaged Weight)

C. GAME INSTALLATION

The following precautions should be followed when installing the game.

- * Avoid rough handling of the game, the picture tube is fragile.
- * Install the game on a level surface.
- * Avoid installing the game where it may receive excessive sunlight or heat, to prevent the game from rising internal temperature.
- * Do not install in a damp or dusty location.
- * For a short time after connecting the power to the game, the picture may be temporarily distorted.

D. DIP SWITCH AND VOLUME CONTROL SETTINGS

Dip Switch A

SETTING	POSITION	1	2	3	4	5	6	7	8
Points For Adding a Sheriff	70,000	ON	ON						
	50,000	OFF	ON						
	30,000	ON	OFF						
	10,000	OFF	OFF						
Hi-Score Name Registration	Name Reg.			ON					
	No Name Reg.			OFF					
No. of Sheriffs	6				ON	ON			
	5				OFF	ON			
	4				ON	OFF			
	3				OFF	OFF			
Test Switch	Test						ON		
	Normal						OFF		
Screen Inversion	1-P Side							ON	
	2-P Side							OFF	
Game Mode	Upright								ON
	TT								OFF

Dip Switch B

	POSITION							
	1 - WAY				2 - WAY			
Play Pricing	1	2	3	4	5	6	7	8
1 Coin - 1 Play	ON	ON	ON	ON	ON	ON	ON	ON
1 Coin - 2 Plays	OFF	ON	ON	ON	OFF	ON	ON	ON
1 Coin - 3 Plays	ON	OFF	ON	ON	ON	OFF	ON	ON
2 Coins - 1 Play	ON	ON	ON	OFF	ON	ON	ON	OFF
3 Coins - 1 Play	OFF	ON	ON	OFF	OFF	ON	ON	OFF

Dip Switch C

SETTING	POSITION	1	2	3	4	5	6	7	8
Display of 1982	No Display						ON		
	Display						OFF		
No Hits are Made By Player	No Hit							ON	
	Normal							OFF	
Coin System	1-Way								ON
	2-WAY								OFF

OPTION SWITCHES
FIGURE 1

SWA

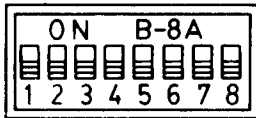

SWB

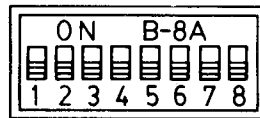

SWC

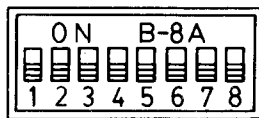

VOLUME CONTROL LOCATIONS
FIGURE 2

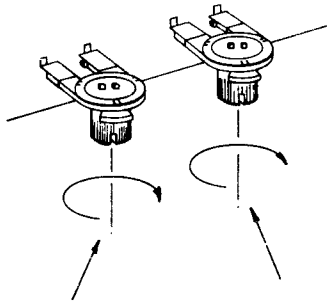

VOLUME CONTROL SETTING

The Volume increases by turning the potentiometer as indicated in Figure 2. The Volume Control is located on the game near the (H) connector.

2. MAINTENANCE

All games require a certain amount of maintenance to keep them in good condition. A periodic check of mechanical controls would be beneficial to guarantee your game will be profitable.

A. CLEANING

The exterior of the game, all metal parts and all plastic parts can be cleaned with a non-abrasive cleanser. Caution should be used when cleaning the plastic, a dry cloth can cause scratches and result in a foggy appearance.

B. FUSE REPLACEMENT

This game contains 8 fuses. Seven of these fuses can be found on the Power Supply Assembly, five (5) are on the PCB and two (2) are on the Power Supply Bracket. One (1) is located at the bracket where the AC line cord comes into the cabinet. See Figure () for location of these fuses.

FUSE REPLACEMENT
FIGURE 3

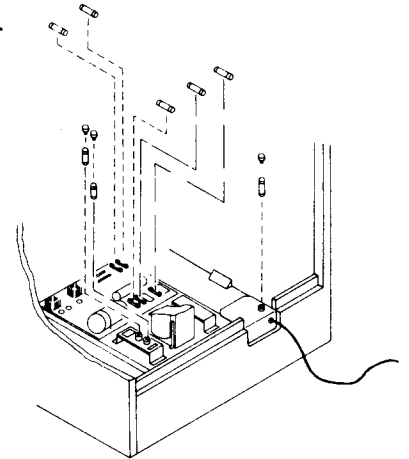

C. VIDEO MONITOR REMOVAL

If you need to remove the Video Monitor, follow the instructions listed below.

CAUTION

It is recommended the game be left disconnected for at least one hour before removing the Video Monitor. This will probably discharge the Video Tube but EXTREME CAUTION is still necessary.

- * Disconnect power from the line voltage.
- * Disconnect the Monitor cable connector.
- * Remove the wire cable clamp.
- * Take out the two side bolts, one on each side of the cabinet.
- * Remove the four mounting bolts and disconnect the green ground wire.
- * Slide the Monitor out by pulling the Monitor toward you.

CAUTION

Use extreme caution and do not touch electrical parts of the Monitor Yoke area with your hands or with any metal object in your hands! High voltages may exist in any Monitor, even with power disconnected.

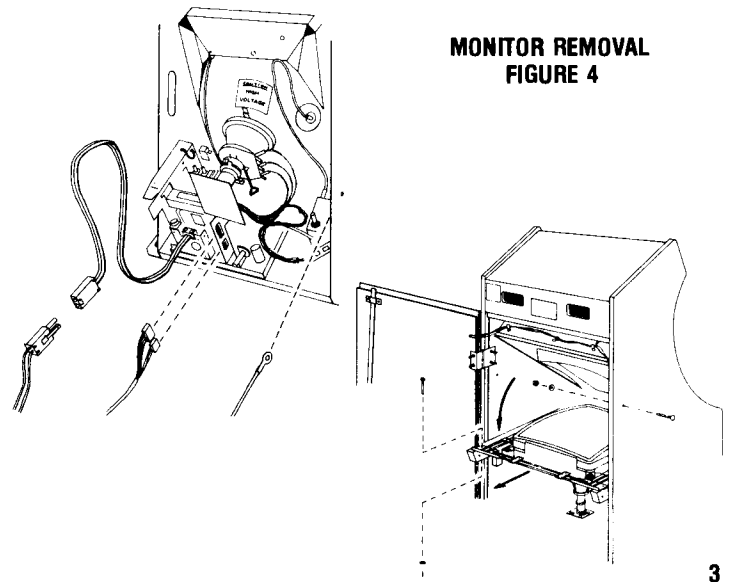

MONITOR REMOVAL
FIGURE 4

D. VIDEO MONITOR ADJUSTMENTS

TAITO AMERICA CORPORATION presently uses either a Wells-Gardner or an Electrohome 19" color monitor in the "WILD WESTERN"™ game. Refer to Monitor Manual (72-00016-001) for your specific Video Monitor. Be sure to heed all the WARNINGS AND CAUTION INSTRUCTIONS provided before repairing or replacing your Video Monitor.

E. COVER GLASS REMOVAL

To remove the Cover Glass follow the Instructions listed below:

1. Remove the control Panel.
2. Loosen three (3) screws on the Cover Glass, front bracket.
3. Open Service Door and remove the (Rear) Cover Glass Bracket.
4. Slide glass out through the Service Door.

**COVER GLASS REMOVAL
FIGURE 5**

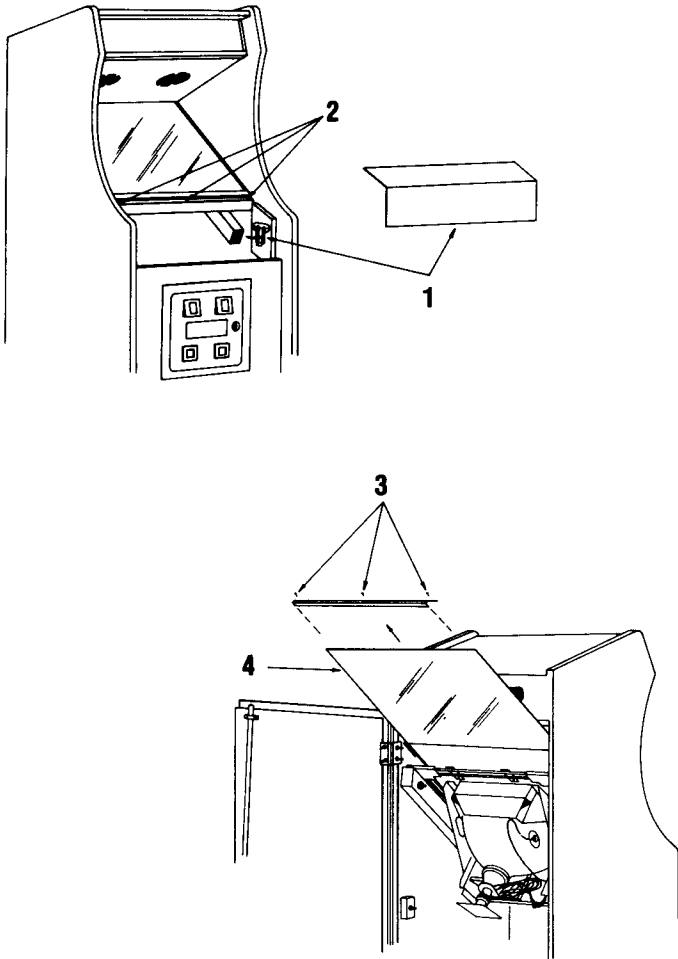

F. PRINTED CIRCUIT BOARD REPLACEMENT

You may wish to remove the "WILD WESTERN"™ Printed Circuit Boards for servicing. Refer to Figure 6.

The "WILD WESTERN" Printed Circuit Boards are located on the inside of the Rear Service Door for easy access.

To remove the boards the following steps should be followed:

1. Open the rear service door, the power will automatically be removed by the Interlock Switch located on the inside of the door frame.
2. Disconnect the connector G, H, and T from the boards.
3. Loosen and turn the Stop Bracket and pull the boards toward you out of the board guides.

**PRINTED CIRCUIT BOARD REPLACEMENT
FIGURE 6**

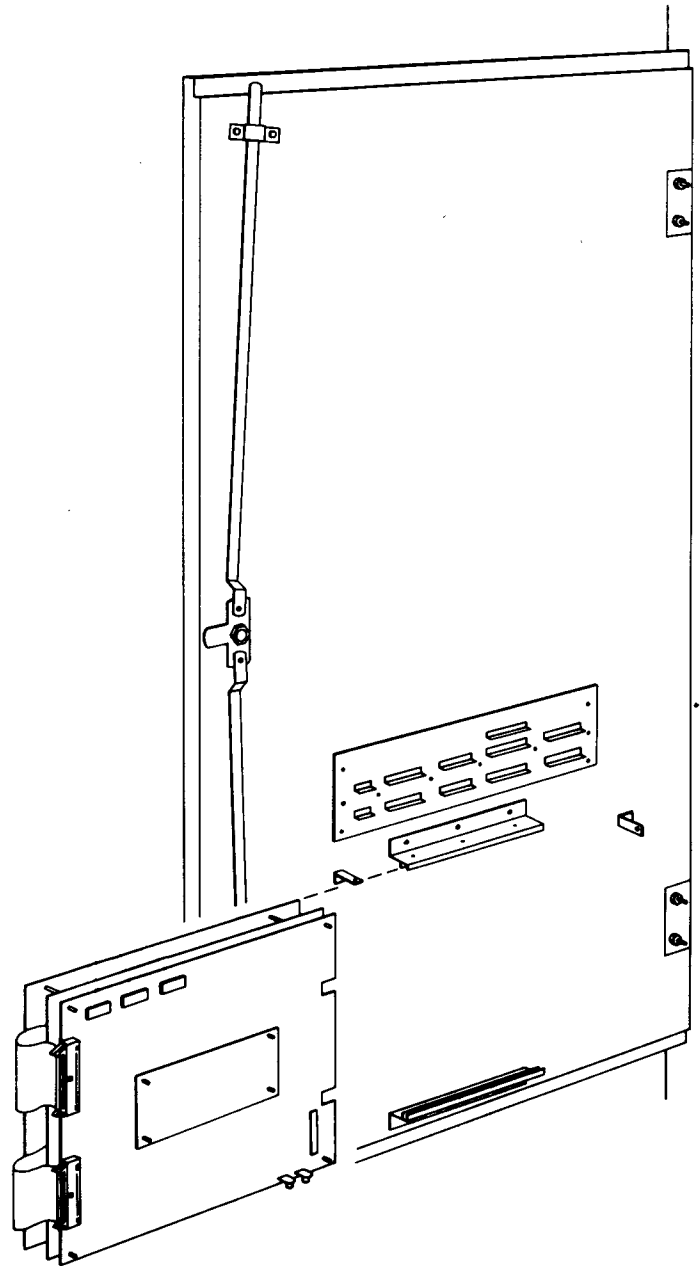

INCANDESCENT PANEL

FIGURE 7

ITEM	TAITO PART NO.	DESCRIPTION
1	27-00006-001	Lamp #47
2	26B00009-001	Bayonet Base Socket
3	61D00112-001	Marquee Lighting Plate

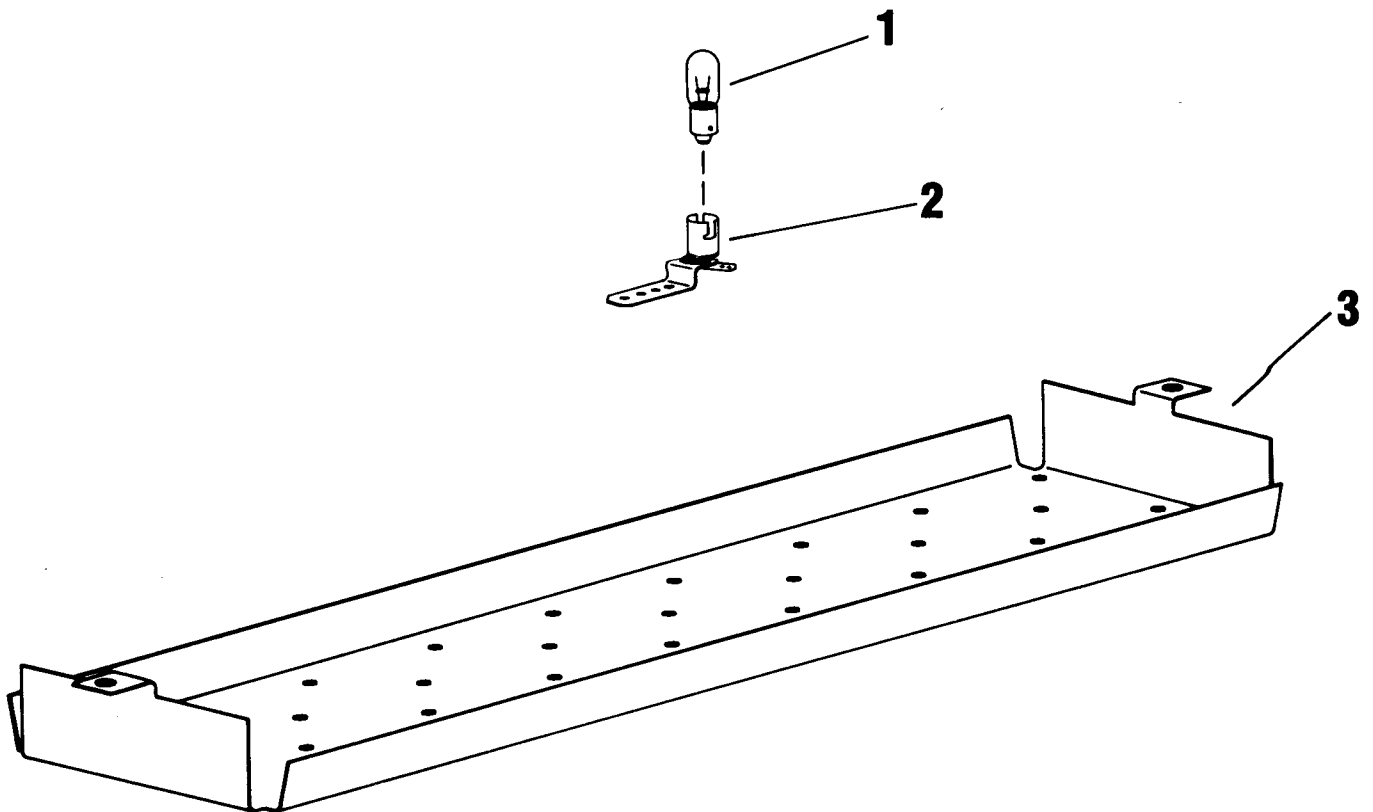

8-WAY JOYSTICK

FIGURE 8

ITEM	TAITO PART NO.	DESCRIPTION
1	63B00031-001	Ball & Shaft
2	63A00033-001	Mask
3	63C00027-001	Mounting Plate
4	62A00002-001	Shock Mount Pad
5	63A00028-001	Switch Plate
6	63A00030-001	Actuator
7	61A00078-001	"L" Ring
8	63C00029-001	Switch Spacer
9	29B00018-001	Leaf Switch
10	63A00029-001	Spacer
11	59B00020-017	"E" Ring

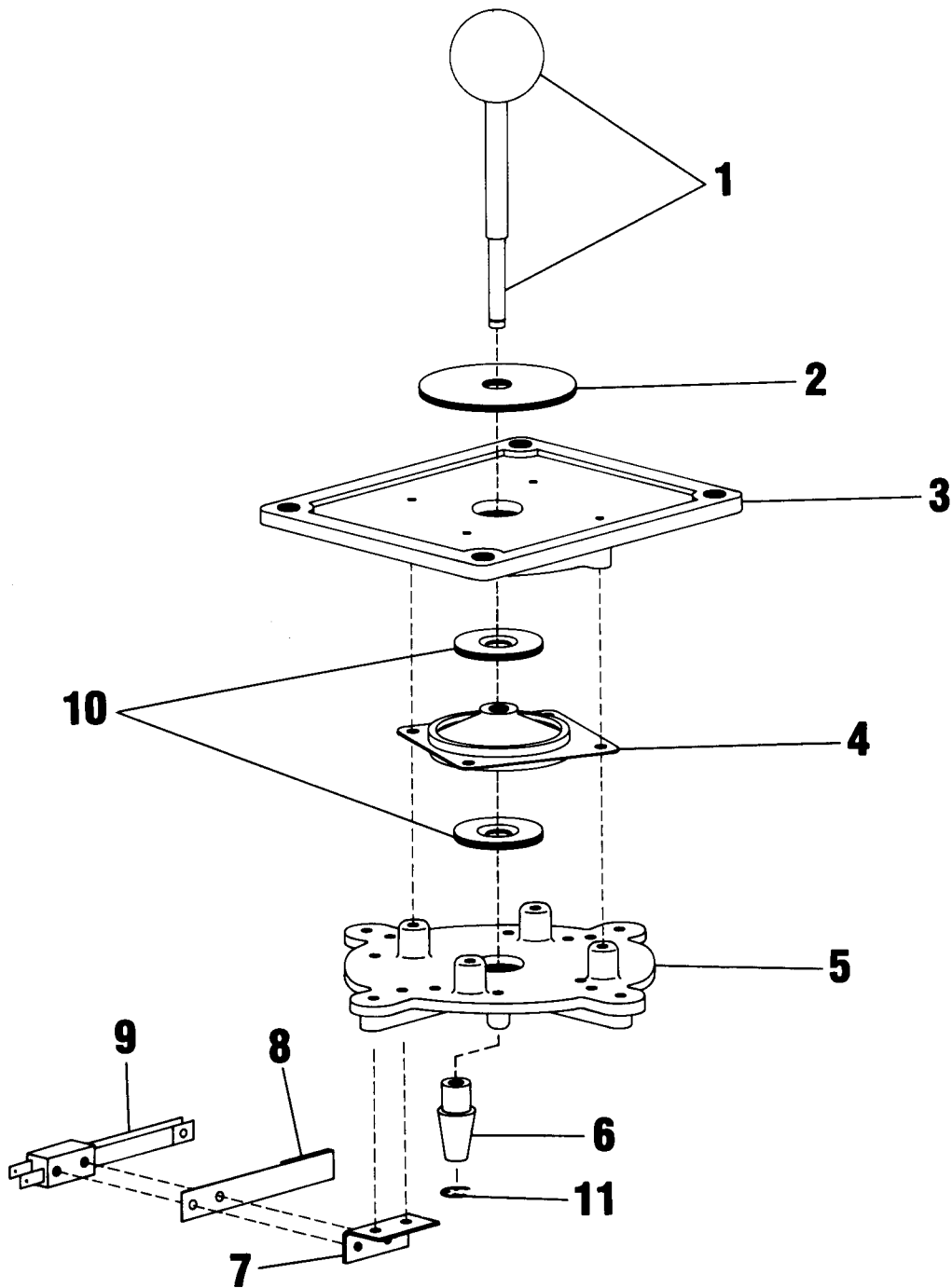

CONTROL PANEL

FIGURE 9

ITEM	TAITO PART NO.	DESCRIPTION
1	63B00031-001	Ball & Shaft
2	63B00024-001	Push Button White
3	42B00108-001	Cleat Wood
4	63D00032-006	8-Way Control
5	07-00136-001	Control Assy., Revolving
6	42B00132-001	Standoff Control Assembly
7	61A00015-001	Strike Hook
8	42D00017-001	Control Panel Wood
9	07M00135-001	Control Panel, Metal
10	63D00086-001	Lexan Decal
11	63-00025-001	Switch Support
12	54A07001-008	Nut, Stamped $\frac{5}{8}$ -11
13	29B00020-001	Switch, Push Button

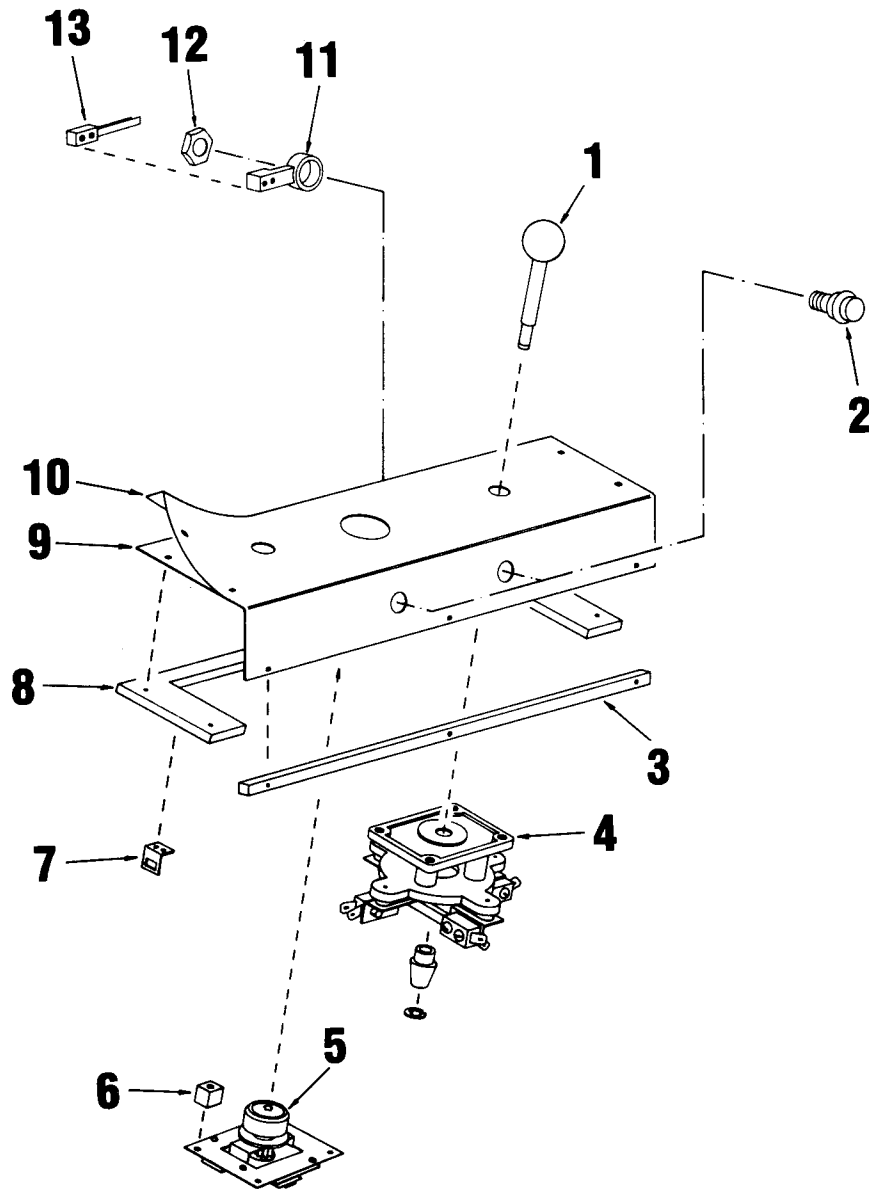

DOOR ASSEMBLY

FIGURE 10

ITEM	TAITO PART NO.	DESCRIPTION	REFERENCE
1	61A00111-001	Bracket, Lock Rod	
2	08-00036-002	Game P.C.B.	AAO 17808
3	08-00036-003	CPU P.C.B.	AAO 17809
4	08-00036-004	Video P.C.B.	AAO 17810
5	08-00028-005	ROM P.C.B.	AAO 17811
6	08-00017-001	Filter P.C.B.	
7	07C00131-001	Bracket P.C. Board	
8	61A00014-001	"L" Bracket	

DOOR ASSEMBLY

FIGURE 10

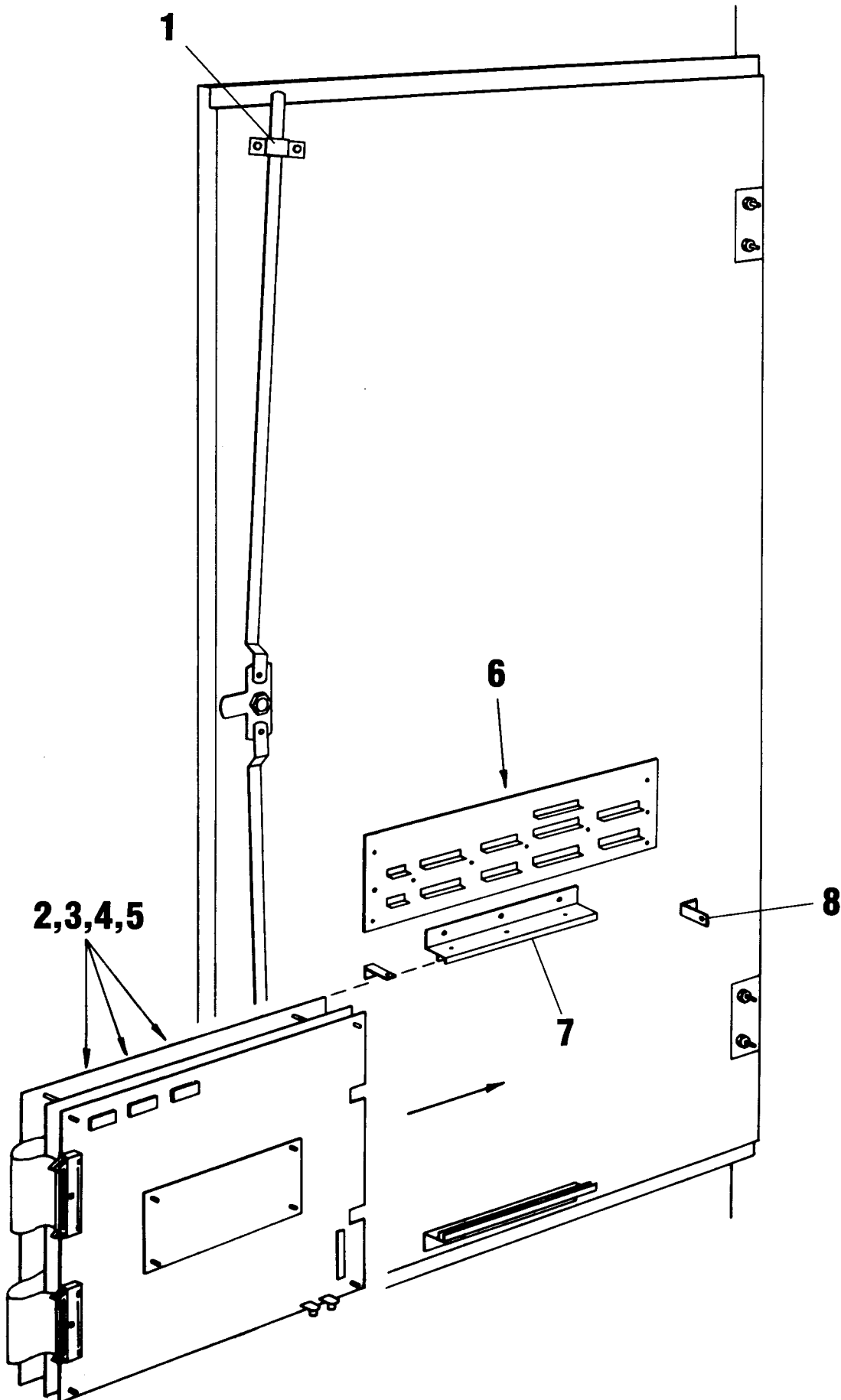

COIN DOOR

FIGURE 11

ITEM	TAITO PART NO.	DESCRIPTION	REFERENCE
1	07-00027-001	Inner Panel With Levers Sub Assembly	404429
2	54-03013-001	Nut #8-32	400-8
*	09-00017-001	Custom Harness Assembly (SHL Coin)	
*	09-00017-002	Custom Harness Assembly (Dual Coin)	
3	61B00113-001	Service Switch Bracket	
4	29-00022-001	Service Switch	
5	54-03011-001	Nut #4-40	
6	63-00014-001	Switch Cover	904762
7	51-02052-001	Screw #6-32 x ³ / ₁₆ SS ph	100-6-3
8	23-00001-001	C.R.E.M. Coil Assembly	404354
9	51-02052-001	Screw #6-32 x ³ / ₁₆ SS ph	100-4-12
10	59-00019-001	Retainer	900651
11	28-00029-001	Silver Switch Wire for U.S. 25¢	904710-1
12	29-00007-001	Switch	904845
13	61-00044-001	Coin Chute	904701
14	61-00045-001	Coin Return Box	904598
15	61-00025-001	Switch & C.R.E.M. Coil Bracket	404428
16	59-00018-001	25¢ Acceptor	5301-10
17	51-02051-006	Screw 4-40 x ³ / ₈ SS ph	110-4-6
18	27-00003-001	Miniature Bayonet Base Lamp	904717
*	26-00006-001	Lamp Socket	
19	27-00003-001	#47 Lamp (6.3 Volt)	904716
20	61-00048-001	Coin Inlet Chute	904418
21	61-00047-001	Right Half of Coin Inlet Chute	904594
22	54-00001-001	"U" Type Fastener	904712
23	51-02051-006	Screw 4-40 x ¹ / ₂ SS ph	116-4-8
24	29-00006-001	Slam Switch Assembly	904704
25	998325	Coin Meters	

*Item not shown on drawing.

COIN DOOR

FIGURE 11

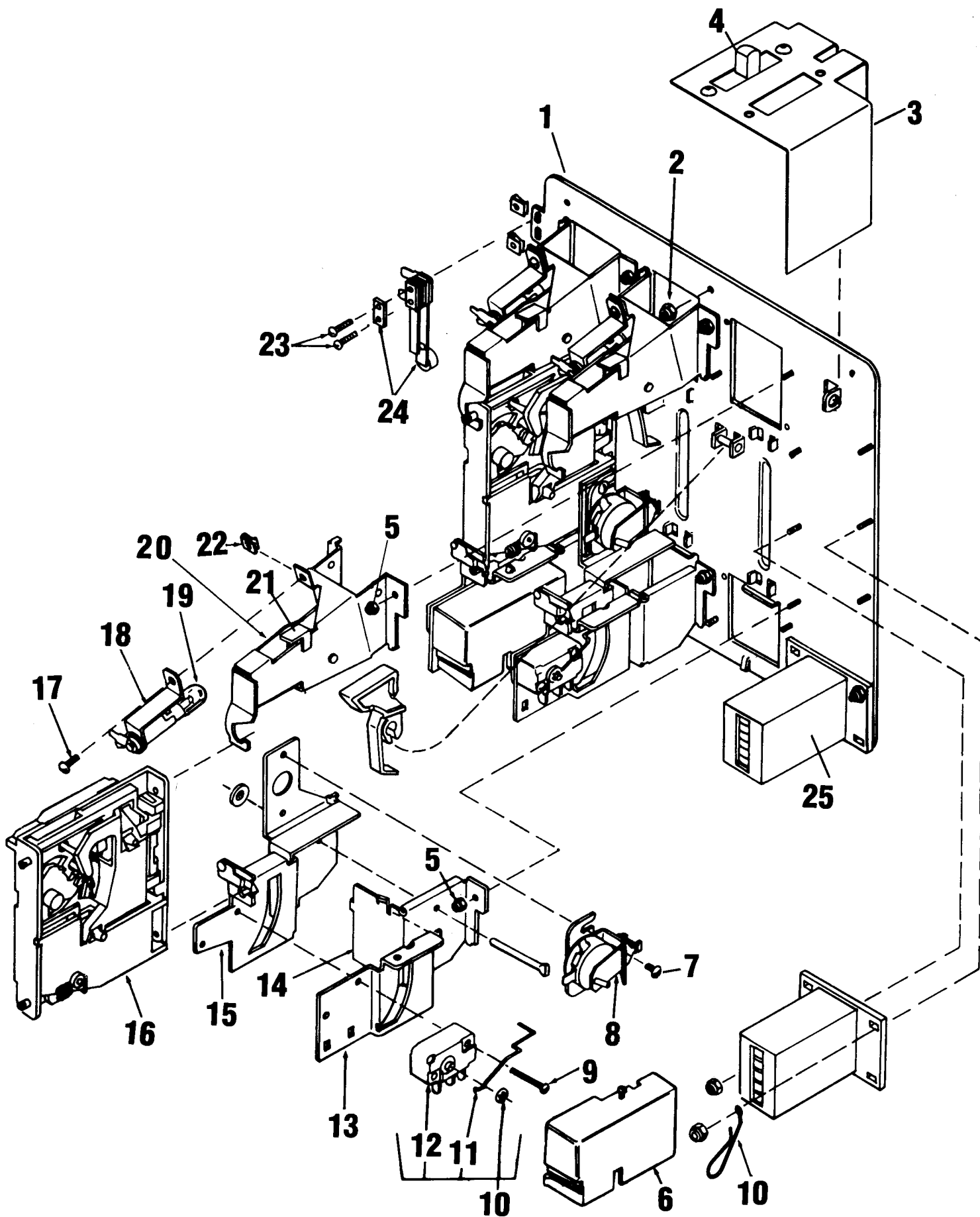

COIN DOOR**FIGURE 12**

ITEM	TAITO PART NO.	DESCRIPTION	REFERENCE
1	61-00042-001	Coin Door Only (2 Coin)	404341
2	07-00023-001	Coin Return Button Assembly For U.S. 25¢ Coin	404348-1
3	63-00015-001	Coin Return Button	904591
4	79-50004-001	U.S. 25¢ Price Decal	904703
5	63-00016-001	Coin Return Button Cover for U.S. 25¢ Coin	
6	07-00025-001	Lock Assembly	904707-1
6A	07-00025-001	Lock Assembly	904707-1
7	51-01051-003	Screw #4 x $\frac{5}{16}$ SL ph Type B	345-4-5
7A	51-01051-003	Screw #4 x $\frac{5}{16}$ SL ph Type B	345-4-5
8	63-00011-001	Coin Button Housing	904588
9	51-02051-002	Screw #4-40 x $\frac{1}{4}$ SL ph	325-4-4
10	63-00012-001	Coin Return Bezel	904590
11	63-00013-001	Coin Return Cover	904599
12	61-00040-001	Coin Door Frame $11\frac{3}{8}$ x $13\frac{3}{8}$ Mounts in a $10\frac{3}{8}$ x $12\frac{3}{16}$ Opening	904581
13	54-01005-001	Hex Nut $\frac{1}{4}$ -20	406-416
14	51A03003-113	Carriage Bolt	904734
15	07-00026-001	Lock Arm Assembly	404357

COIN DOOR

FIGURE 12

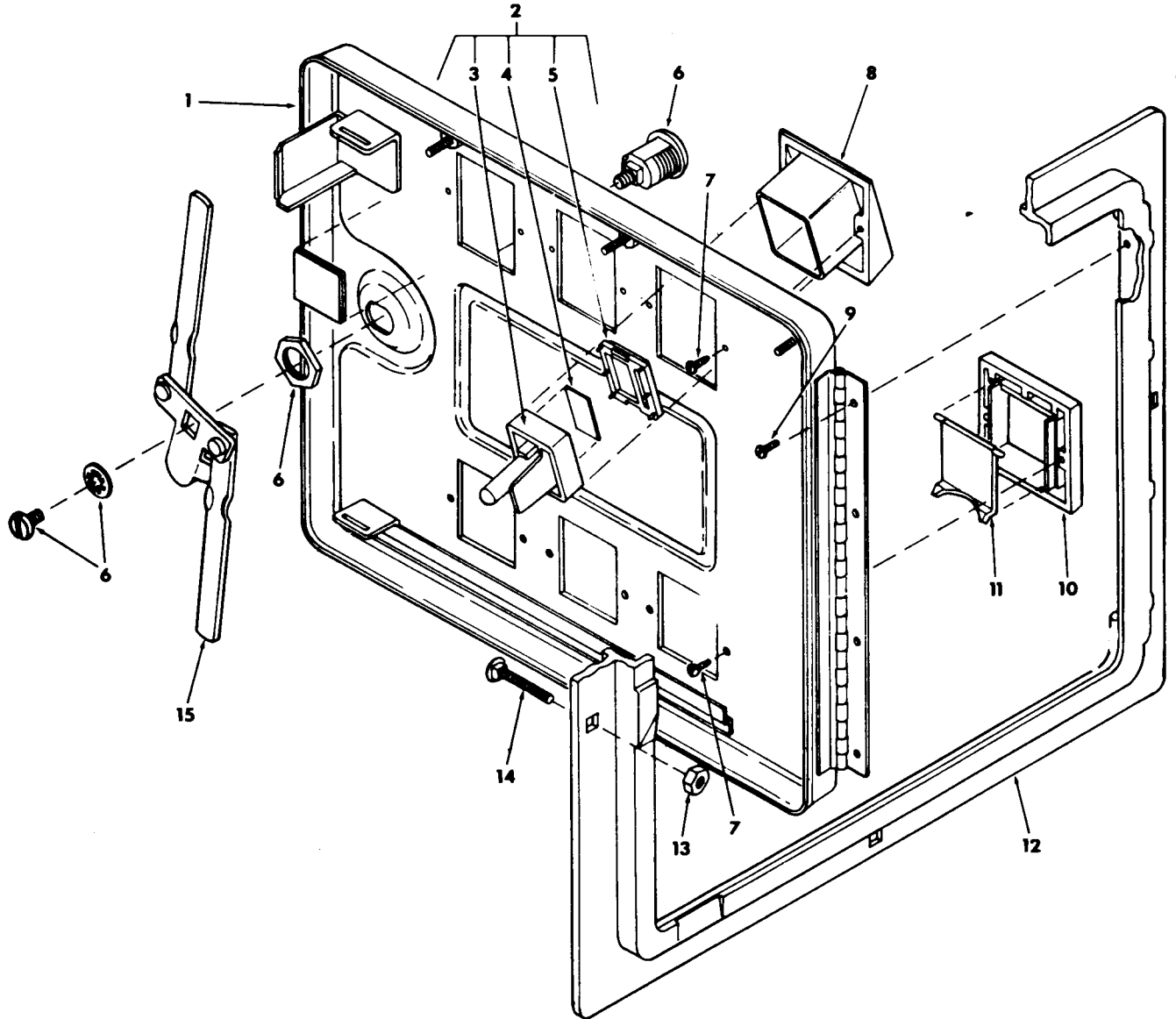

CABINET ASSEMBLY FRONT VIEW**FIGURE 13**

ITEM	TAITO PART NO.	DESCRIPTION
1	07M00055-002	Incandescent Panel
2	63B00006-003	"U" Channel Bracket
3	47D00012-008	Marquee
4	61C00115-001	Marquee Retaining Bracket
5	61D00012-001	Lower Coverglass Bracket
6	07-00132-001	Control Panel Assembly
7	07-00050-001	Coin Door
8	61B00113-001	Switch Bracket
9	07-00118-001	Service Switch Assembly
10	29-00022-001	Slide, Center Return Switch
11	29B00015-001	Interlock Switch
12	61B00114-001	Interlock Switch Bracket
13	59-00008-001	Latching Clamp
14	63B00002-004	"T" Molding
15	29A00023-001	Power ON/OFF Switch
16	41-00015-003	Finished Cabinet

CABINET ASSEMBLY FRONT VIEW

FIGURE 13

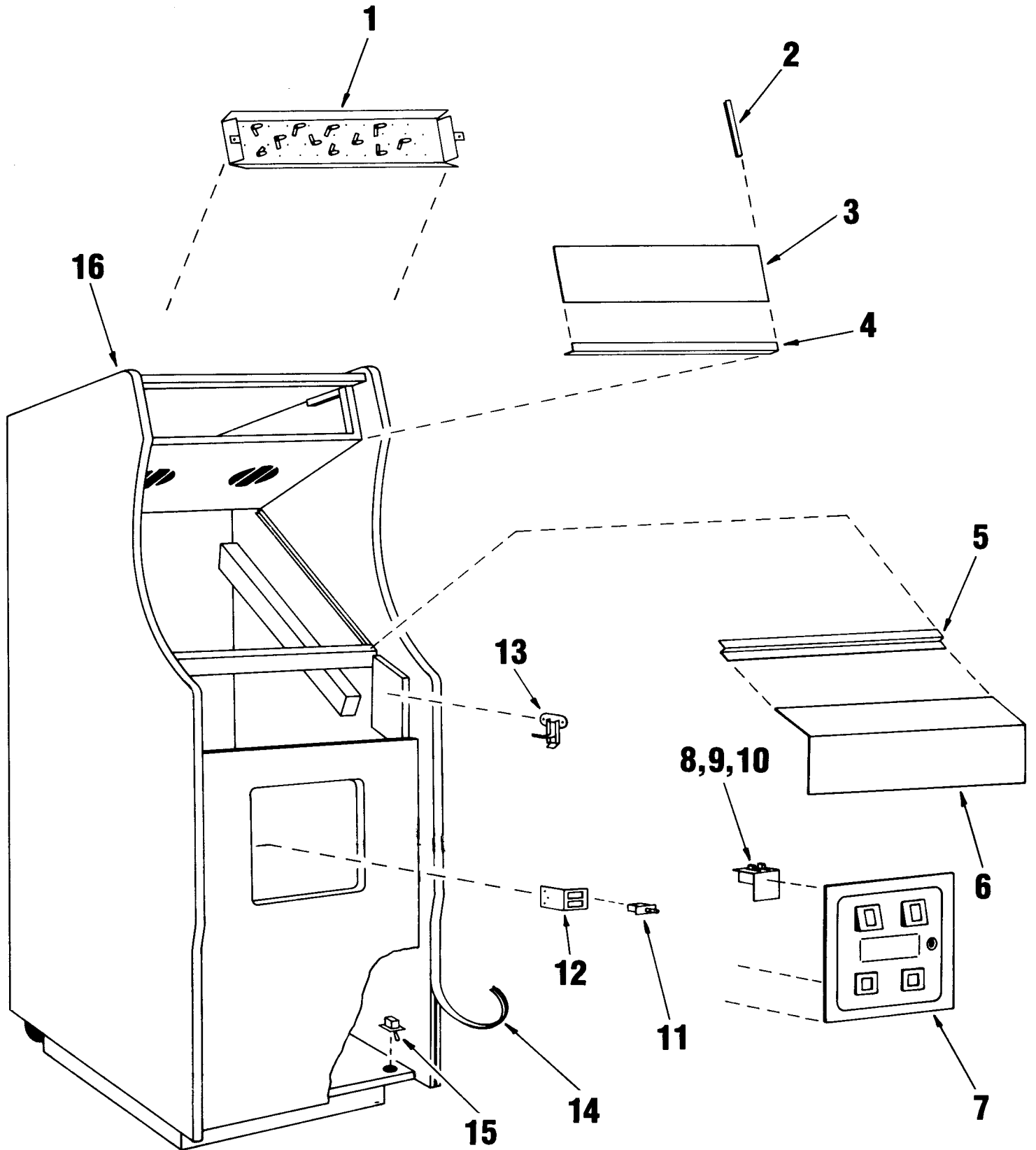

CABINET ASSEMBLY REAR VIEW**FIGURE 14**

ITEM	TAITO PART NO.	DESCRIPTION
1	07-00083-001	Speaker
2	61B00038-001	Speaker Grill
3	41D00015-003	Finished Cabinet
4	63C00005-004	(L) Molding
5	07M00042-001	A/C Line Cord Assembly
6	63C00005-002	Lock Kit
7	61B00030-002	Interlock Bracket
8	29B00015-001	Interlock Switch
9	07M00039-001	Power Supply
10	61C00054-001	Cash Box Lid
11	61D00060-001	Cash Box
12	07M00054-001	Cash Tray Assembly
13	63R00010-001	Cash Tray (only)
14	63-00019-001	Cash Tray Separator
15	61B00039-001	Cash Tray Handle
16	42C00013-001	Monitor Support Cleat
17	61D00208-001	Monitor M.T.G
18	31-00011-001	19" Color Monitor
19	26-00010-001	Socket Lamp Clip-on Mini-Bay
20	27-00006-001	#47 Bulb
21	47M00013-008	Coverglass
22	63C00035-001	Monitor Shroud
23	61C00006-001	Upper Cover Glass Bracket
24	61-000142-001	Lock Rod Assembly
25	04-00037-002	Lock Assembly
26	44-00001-001	Wheel Assembly
27	42-00134-001	Back Door

CABINET ASSEMBLY REAR VIEW

FIGURE 14

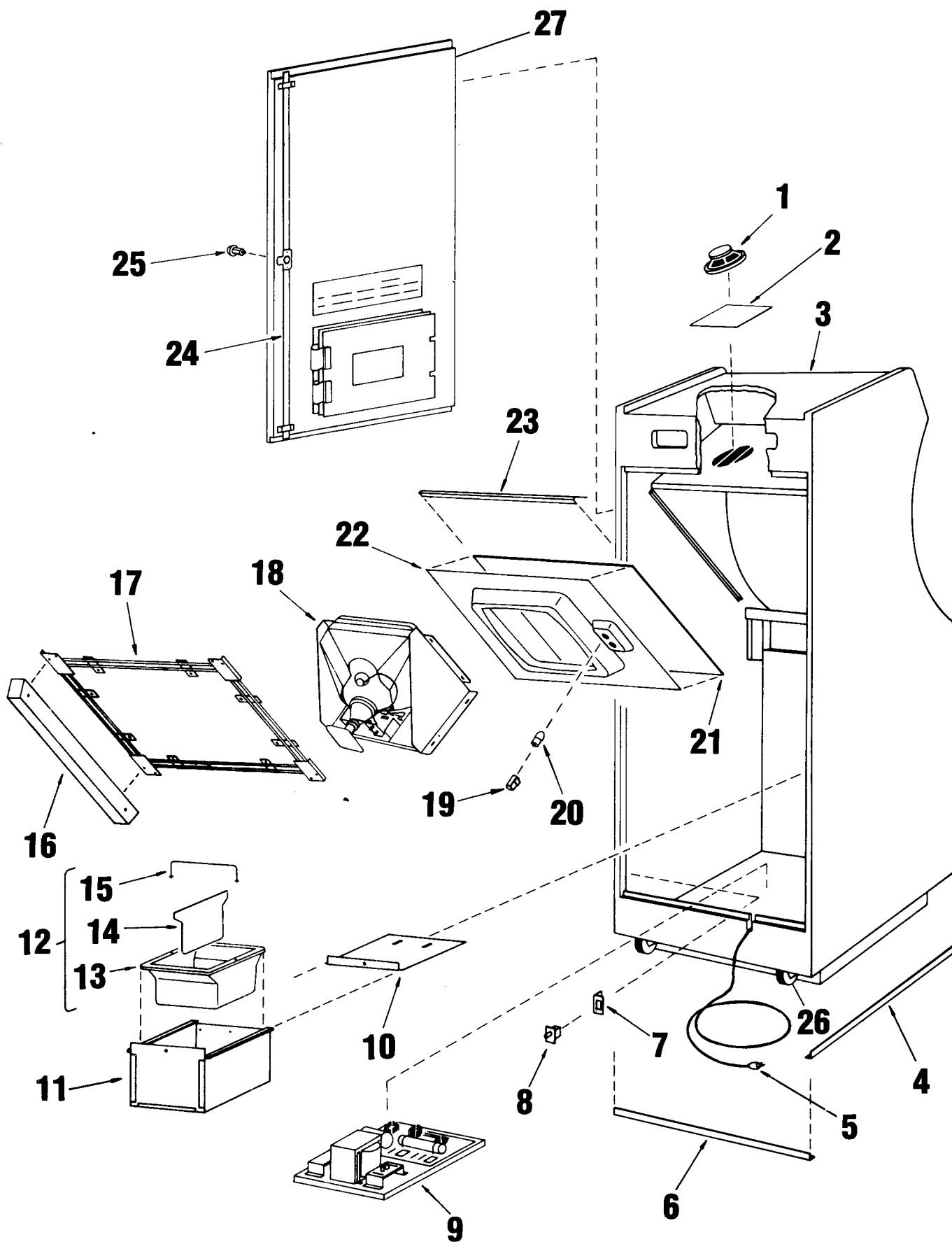

REVOLVING CONTROL ASSEMBLY (WWK00003)

FIGURE 15

ITEM	TAITO PART NO.	DESCRIPTION
1	99-WW090002	Knob
2	99-WW020006	Roll Pin
3	99-AA019609	Plastic Washer
4		Pan Hd. Screw M4 x 14
5	99-WW020004	¼" Steel Ball
6	99-WW050002	Spring
7	99-WW020003	Spring Guide
8	99-AA012510	Spacer
9	99-WW020005	Adjust Pipe
10	99-WW050001	Spring
11	99-WW020002	Parallel Key
12	99-WW040002	CAM
13		Plain Washer
14	99-AA013658	Tap Plate
15		Flange Nut M4
16	99-WW030002	Base Bracket "B"
17	99-AA013658	Tap Plate
18	99-AA019504	Insulator
19	99-AA052532	Micro Switch V10FL22-1C28
20		Bind Hd. Screw M 3 x 16
21	99-AA019504	Insulator
22	99-AA052531	Micro Switch
23		Bind Hd. Screw M3 x 16
24		Pan Hd. Screw M4 x 6
25		Lock Washer 4M
26	99-WW030003	M.S. Base
27	99-WW040001	Gear
28		Plain Washer 9.5 dia x 15 dia x 1.6 thick
29		Screw M4 x 6
30		Spring Washer 4M
31	61A-00244-001	Inlay Knob
32	99-WW030001	Base Bracket "A"

REVOLVING CONTROL ASSEMBLY (WWK00003)

FIGURE 15

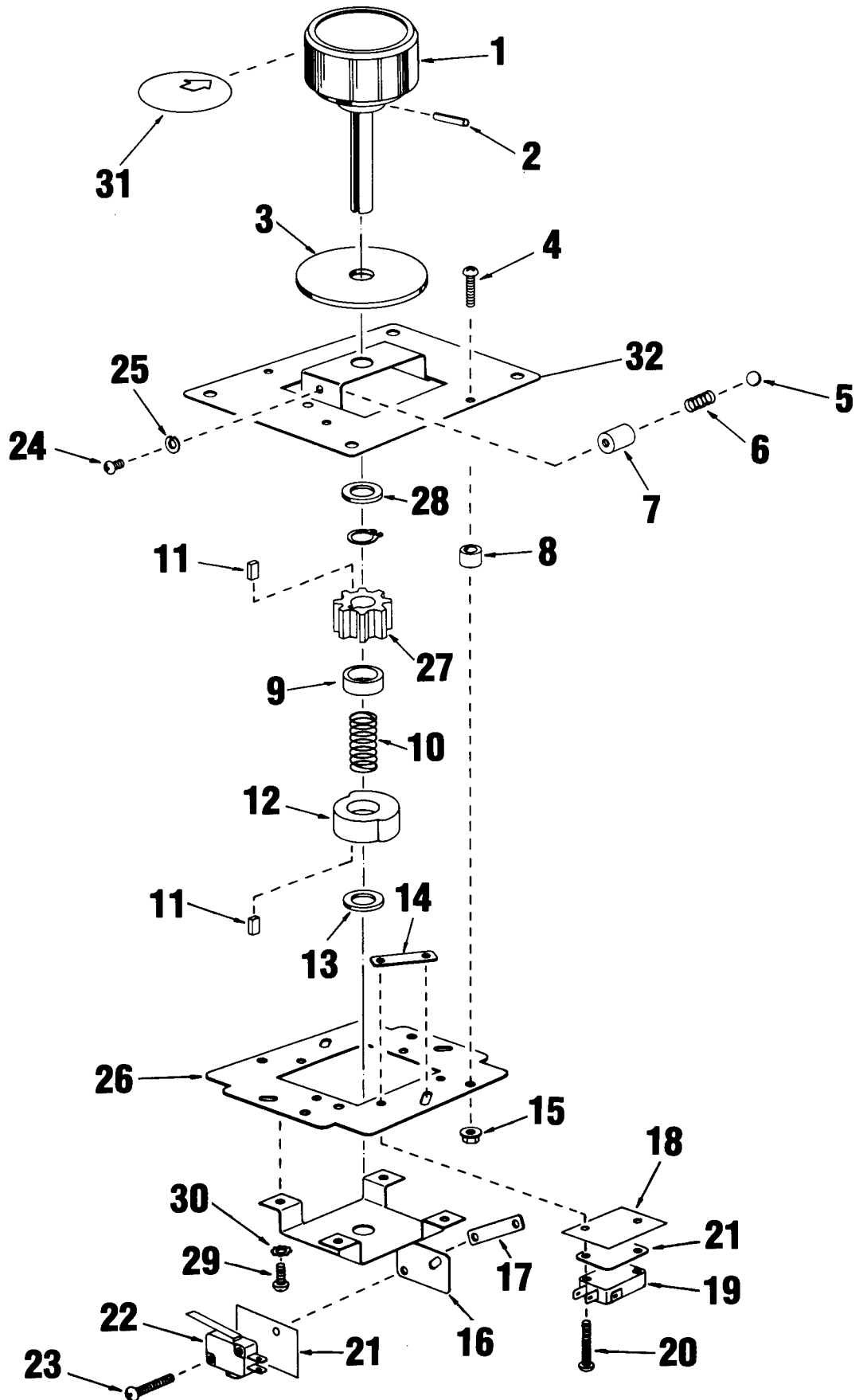

FILTER BOARD

FIGURE 16

ITEM	TAITO PART NO.	DESCRIPTION	QUANTITY
1	12-10003-471	Cap, 470pf ± 10% Axial Lead	74
2	17-00001-001	Ferrite Bead Assembly	42
3	25-00002-014	Connector 14P	9
4	25-00002-005	Connector 5P	2
5	14-23904-001	Transistor NPN 2N3904	1
6	11-00001-102	Resistor 1K ohm ¼W	1
7	11-00001-332	Resistor 3.3F ohm ¼W	2
8	63B00068-001	Stand Off	6

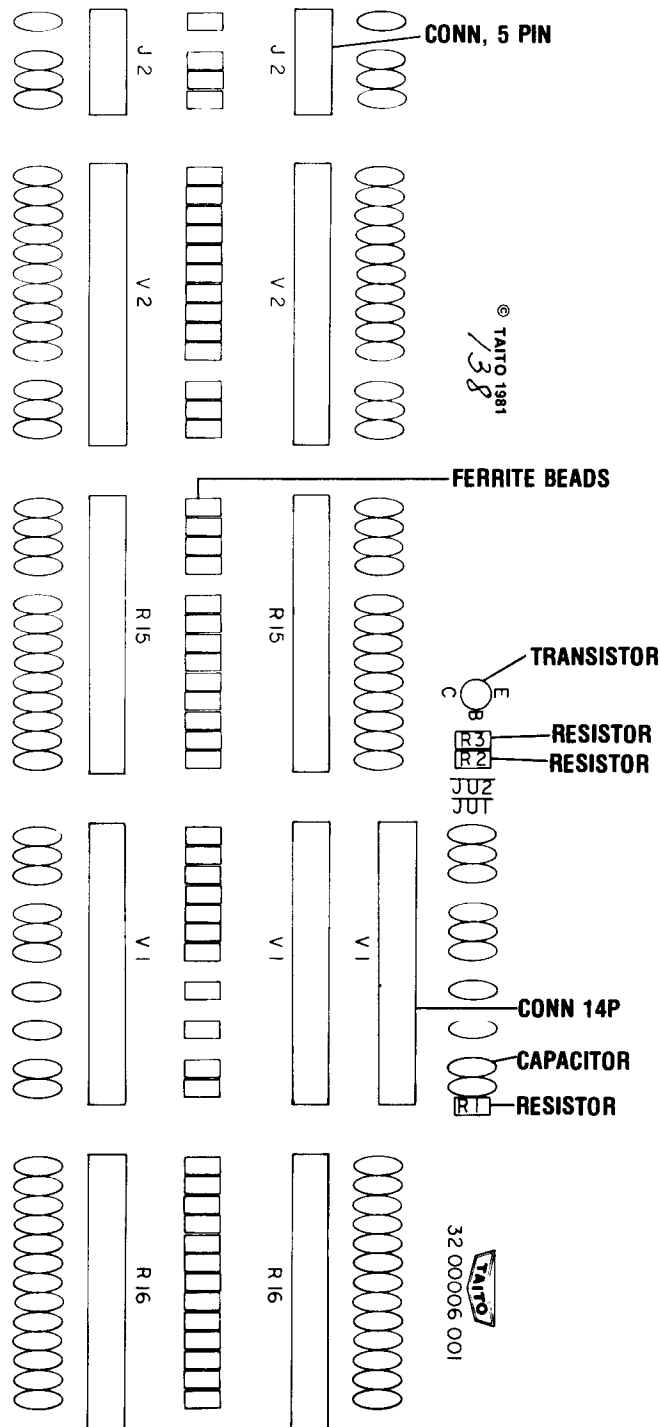

POWER SUPPLY

FIGURE 17

SYM	TAITO PART NO.	DESCRIPTION
R1	11-00001-102	Resistor 1.0K 5% ¼W 5%
R2	11-00001-512	Resistor 5.1K ¼W 5%
R3	11-00001-183	Resistor 18K ¼W 5%
R4	11-00001-224	Resistor 220K ¼W 5%
R5	11-00001-472	Resistor 4.7K ¼W 5%
R6	11-00001-222	Resistor 2.2K ¼W 5%
R7	11-10001-101	Resistor 100 ¼W 5%
R8	11-00001-102	Resistor 10K ¼W 5%
R9	11-00001-472	Resistor 4.7K ¼W 5%
R10	11-10001-101	Resistor 100 ½W 5%
R11	11-30001-015	Resistor .15 4W 5%
R12	11-30001-015	Resistor .15 4W 5%
R13	11-00001-472	Resistor 4.7K ¼W 5%
R14	11-00001-222	Resistor 2.2K ¼W 5%
R15	11-00001-222	Resistor 2.2K ¼W 5%
R16	11-60001-252	Pot 2.5K ¼W 20%
R17	11-00001-222	Resistor 2.2K ¼W 5%
R18	11-60001-102	Pot 1.0K ¼W 20%
R19	11-00001-511	Resistor 510 ¼W 5%
R20	11-10001-470	Resistor 47 ½W 5%
R21	11-00001-162	Resistor 1.6K ¼W 5%
R22	11-00001-103	Resistor 10K ¼W 5%
R23	11-00001-472	Resistor 4.7K ¼W 34
R24	11-00001-222	Resistor 2.2K ¼W 5%
R25	11-60001-102	Pot 1.0K ¼W 5%
R26	11-00001-472	Resistor 407K ¼W 5%
R27	11-00001-222	Resistor 2.2K ¼W 5%
R28	11-60001-252	Pot 2.5K ¼W 20%
R29	11-00001-472	Resistor 4.7K ¼W 5%
R30	11-00001-122	Resistor 1.2K ¼W 5%
R31	11-10001-470	Resistor 47 ¼W 5%
R32	11-30001-015	Resistor .15 4W 5%
R33	11-00001-222	Resistor 2.2K ¼W 5%
R34	11-00001-122	Resistor 1.2K ¼W 5%
R35	11-00001-511	Resistor 510 ¼W 5%
R36	11-00001-222	Resistor 2.2K ¼W 5%
R37	11-00001-104	Resistor 100K
R38	11-00001-103	Resistor 10K ¼W 5%
R39	11-00001-224	Resistor 220L ¼W 5%
C1	12-30001-225	Capacitor, Tantalum 2.2uf 25V
C2	12-10004-103	Capacitor, Ceramic .01uf
C3	12-10004-103	Capacitor, Ceramic .01uf
C4	12-30001-105	Capacitor, Tantalum 1.uf 35V

SYM	TAITO PART NO.	DESCRIPTION
C5	12-10001-102	Capacitor, .001uf
C6	12-30001-106	Capacitor, Tantalum 10uf
C7	12-20003-509	Capacitor, Electrolytic 50,000uf
C8	12-30001-105	Capacitor, Tantalum 1.uf 35V
C9	12-20003-209	Capacitor, Electrolytic 20,000uf
C10	12-10001-332	Capacitor, Ceramic .0033uf
C11	12-30001-476	Capacitor, Tantalum 47uf
C12	12-30001-105	Capacitor, Tantalum 1.uf 35V
C13	12-10004-103	Capacitor, Ceramic .01uf
C14	12-10001-102	Capacitor, .001uf
C15	12-30001-476	Capacitor, Tantalum 47uf
C16	12-20002-108	Capacitor, Electrolytic 1,000uf
C17	12-30001-225	Capacitor, Tantalum 2.2uf 25V
C18	12-30001-225	Capacitor, Tantalum 2.2uf 25V
C19	12-30001-105	Capacitor, Tantalum 1.uf 35V
F1	24-00003-010	10A Fuse
F2	24-00003-010	10A Fuse
F3	24-00003-003	Fuse, 2A
F4	24-00003-004	Fuse, 4A
F5	24-00003-004	Fuse, 4A
BR1	13-00100-025	Diode Bridge 25A, 100V
BR2	13-00100-012	Diode Bridge 12A, 100V
BR3	13-00100-002	Diode Bridge 2A, 100V
D1	13-14002-001	Diode IN4002
D2	13-14002-001	Diode IN4002
D3	13-10752-001	Diode, Zener IN752
D4	13-14002-001	Diode IN4002
D5	13-14002-001	Diode IN4002
D6	13-14002-001	Diode IN4002
D7	13-10964-001	Diode, Zener IN964
D8	13-14002-001	Diode IN4002
D9	13-14002-001	Diode IN4002
D10	13-14002-001	Diode IN4002
D11	13-14002-001	Diode IN4002
D12	13-14002-001	Diode IN4002
LED1	13-00001-001	LED (Red)
LED2	13-00001-001	LED (Red)
LED3	13-00001-001	LED (Red)
LED4	13-00001-001	LED (Red)
U1	15-62500-001	Opto Coupler H11AA2
U2	15-50556-001	Timer (Dual) 556
U3	15-50723-001	Voltage Regulator 723
U4	15-50723-001	Voltage Regulator 723

POWER SUPPLY

FIGURE 17

SYM	TAITO PART NO.	DESCRIPTION
REG1	15-57912-001	Voltage Regulator 7912
REG2	15-57905-001	Voltage Regulator 79L05
Q1	14-22905-001	Transistor 2N2905
Q2	14-22905-001	Transistor 2N2905
Q3	14-22905-001	Transistor 2N2905
Q4	14-22905-001	Transistor 2N2905
Q5	14-23055-001	Transistor 2N3055
Q6	14-22905-001	Transistor 2N2905
Q7	14-20030-001	Transistor TIP-30A
Q8	14-26401-001	SCR 2N6401
Q9	14-26401-001	SCR 2N6401
J1	25-00022-006	Connector, 1-380999-0 6Pin
J2	25-00022-008	Connector, 350212-1 8Pin
J3	25-00002-014	Connector, 09-60-1141 14Pin
J4	25-00002-014	Connector, 09-60-1140 14Pin
	24-10001-001	Fuse Clips
	30-00220-002	Heat Sink Dual To-220
	30-00003-001	Heat Sink Single To-3

POWER SUPPLY COMPONENT LAYOUT

FIGURE 17

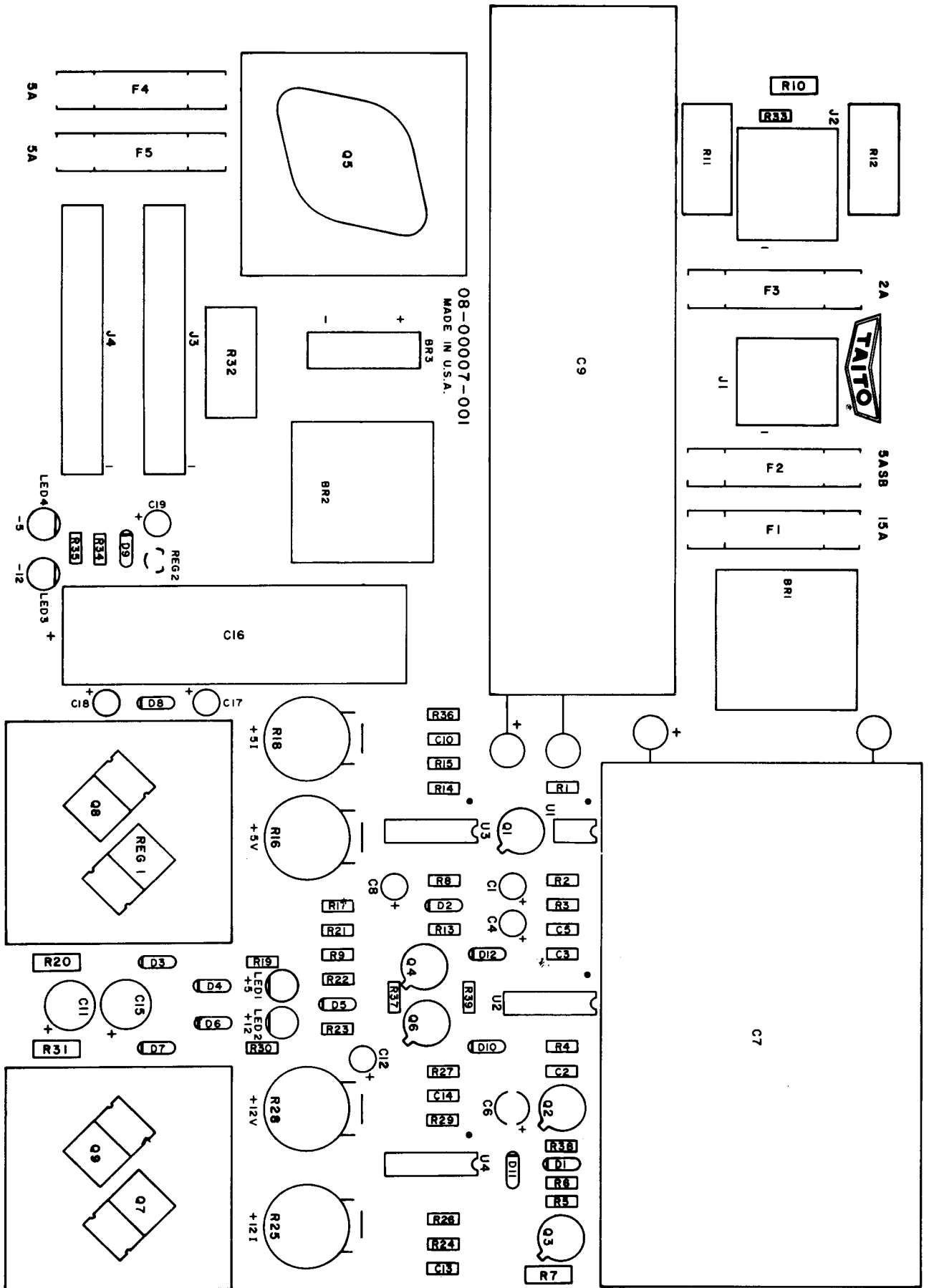

ROM BOARD**FIGURE 18**

ITEM	SYM	TAITO PART NO.	DESCRIPTION
1		99-WW070004	ROM PC BOARD
2			NOT USED
3	30P	99-AA055161	CONNECTOR SOCKET HKP-30FD
4	1S	99-AA055787	IC - SOCKET 24P
5			NOT USED
6	IC1	99-AAT33096	LS - IC 74LS138
7	IC2	99-AAT36071	CMOS 40193
8	ROM 1	99-WW090408	PROM (2732) WW08
9	ROM 2	99-WW090409	PROM (2732) WW09
10	ROM 3	99-WW090410	PROM (2732) WW10
11	ROM 4	99-WW090411	PROM (2732) WW11
12	ROM 5	99-WW090412	PROM (2732) WW12
13	ROM 6	99-WW09041	PROM (2732) WW13
14			NOT USED
15			NOT USED
16			NOT USED
17	C1	99-AAT41244	CAP, FILM TDY-1H-104
18	C2	99-AAT41430	CAP, TANTALUM SSG25-10F
19	C3	99-AAT41436	CAP, TANTALUM SSG35-1F
20	R	99-AAT51765	RES, CARBON 1 KOHM ¼W 5%
21	RB	99-AA062637	TINNED COPPER WIRE 10
22			NOT USED
23	S1	99-WW070213	PC BOARD STICKER WWN00004

ROM BOARD COMPONENT LAYOUT

FIGURE 18

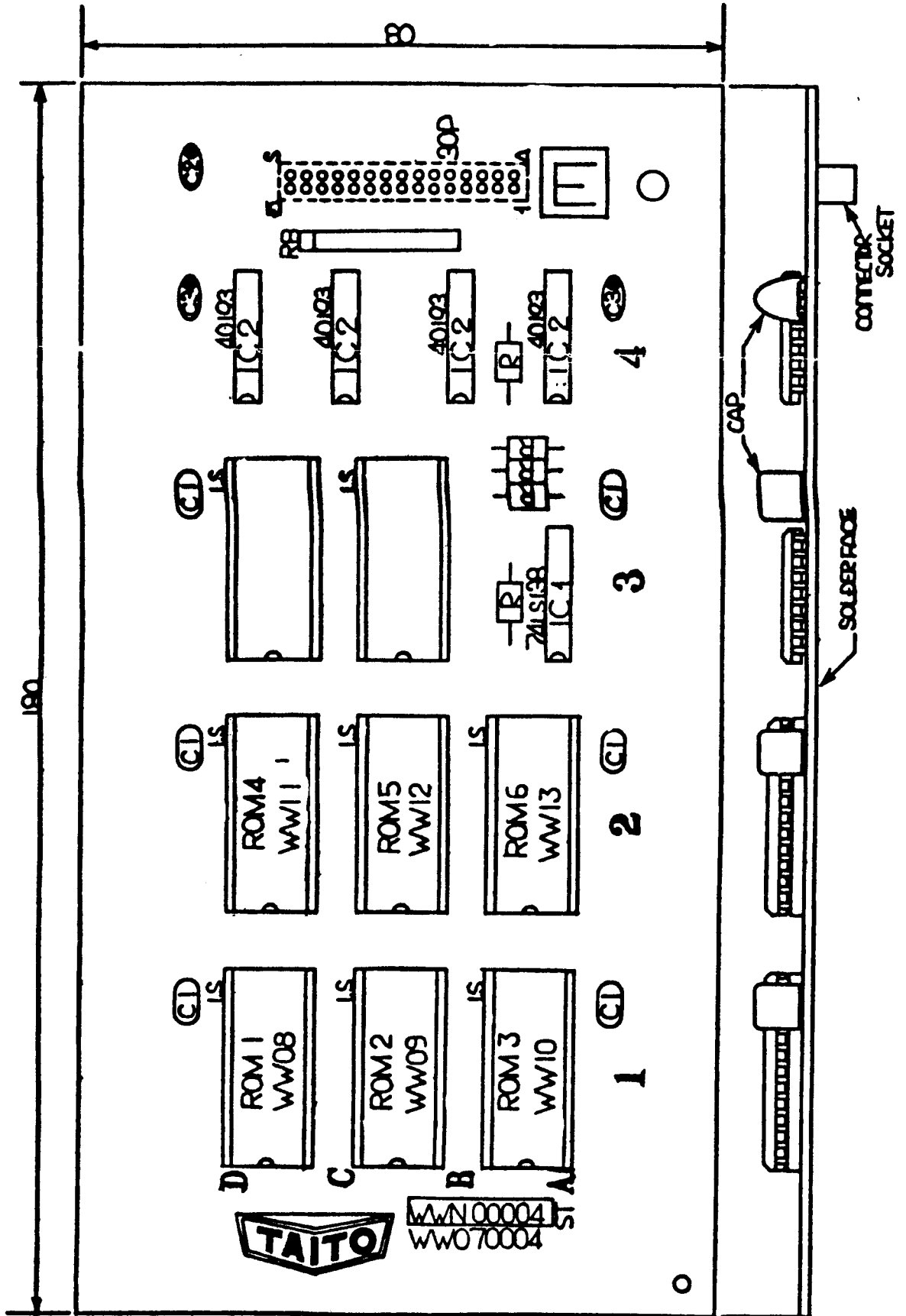

CPU BOARD

FIGURE 19

ITEM	SYM	TAITO PART NO.	DESCRIPTION
1		99-WW070003	CPU BOARD
2	ST	99-WW070202	PC BOARD STICKER WWN00003
3	50P	99-AA055310	ANGLE PIN HEADER PS-50P
4	1S1	99-AA055787	IC - SOCKET 24P
5	1S2	99-AA055812	IC - SOCKET 40P
6	TP	99-AA056551	TEST POINT
7	XTAL 2	99-AA069605	X-TAL 12MHZ
8	XTAL 1	99-AA069608	X-TAL 8MHZ
9	1S3	99-AA055103	IC - SOCKET 18P
10	CB	99-AA069557	LOCKING CIRCUIT BOARD SUPPORT
11	IC1	99-AAT32163	STATIC RAM 2114-7
12	IC2	99-AAT32178	STATIC RAM TMM2016P
13	IC3	99-AAT33001	LS-IC 74LS00
14	IC4	99-AAT33003	LS-IC 74LS02
15	IC5	99-AAT33005	LS-IC 74LS04
16	IC6	99-AAT33009	LS-IC 74LS08
17	IC7	99-AAT33011	LS-IC 74LS10
18			NOT USED
19	IC9	99-AAT33027	LS-IC 74LS32
20	IC10	99-AAT33051	LS-IC 74LS74
21	IC11	99-AAT33059	LS-IC 74LS83
22	IC12	99-AAT33061	LS-IC 74LS85
23	IC13	99-AAT33062	LS-IC 74LS86
24	IC14	99-AAT33096	LS-IC 74LS138
25	IC15	99-AAT33112	LS-IC 74LS157
26	IC16	99-AAT33116	LS-IC 74LS161
27	IC17	99-AAT33119	LS-IC 74LS164
28	IC18	99-AAT33126	LS-IC 74LS173
29	IC19	99-AAT33127	LS-IC 74LS174
30	IC20	99-AAT33128	LS-IC 74LS175
31	IC21	99-AAT33203	LS-IC 74LS367
32	IC22	99-AAT33209	LS-IC 74LS374

ITEM	SYM	TAITO PART NO.	DESCRIPTION
33	IC23	99-AAT33220	LS-IC 74LS393
34	CPU	99-AAT34008	CPU 7-80A
35	IC24	99-AAT32003	TTL-IC 7404
36	IC25	99-AAT32099	TTL-IC 74367
37	C1	99-AAT41023	CAP, ELECTROLYTIC 16VB220
38	C2	99-AAT41244	CAP, FILM TDY-1H-104
39	C3	99-AAT41302	CAP, CERAMIC 22PF50V
40	C4	99-AAT41324	CAP, CERAMIC 180PF50V
41	C5	99-AAT41330	CAP, CERAMIC 330PF50V
42	C6	99-AAT41411	CAP, CERAMIC 10000P50V
43	C7	99-AAT41436	CAP, TANTALUM SSG35-1F
44	R1	99-AAT51749	RES, CARBON 220 OHM ¼W 5%
45	R2	99-AAT51253	RES, CARBON 330 OHM ¼W 5%
46	R3	99-AAT51265	RES, CARBON 1 KOHM ¼W 5%
47			NOT USED
48	ROM 1	99-WW090401	PROM (2732) WW01
49	ROM 2	99-WW090401C	PROM (2732) WW02
50	ROM 3	99-WW090403	PROM (2732) WW03
51	ROM 4	99-WW090404	PROM (2732) WW04
52	ROM 5	99-WW090405	PROM (2732) WW05
53	ROM 6	99-WW090406	PROM (2732) WW06
54	ROM 7	99-WW090407	PROM (2732) WW07
55			NOT USED
56			NOT USED
57			NOT USED
58	IC26	99-AAT38003	S-IC 74S04
59	IC27	99-AAT32006	TTL-IC 7475
60			NOT USED
61	C8	99-AAT41318	CAP, CERAMIC DT-201 100pf 50V
62	RB	99-AAT55038	RES BLOCK 1 OHM 8 ELEMENTS

CPU BOARD COMPONENT LAYOUT

FIGURE 19

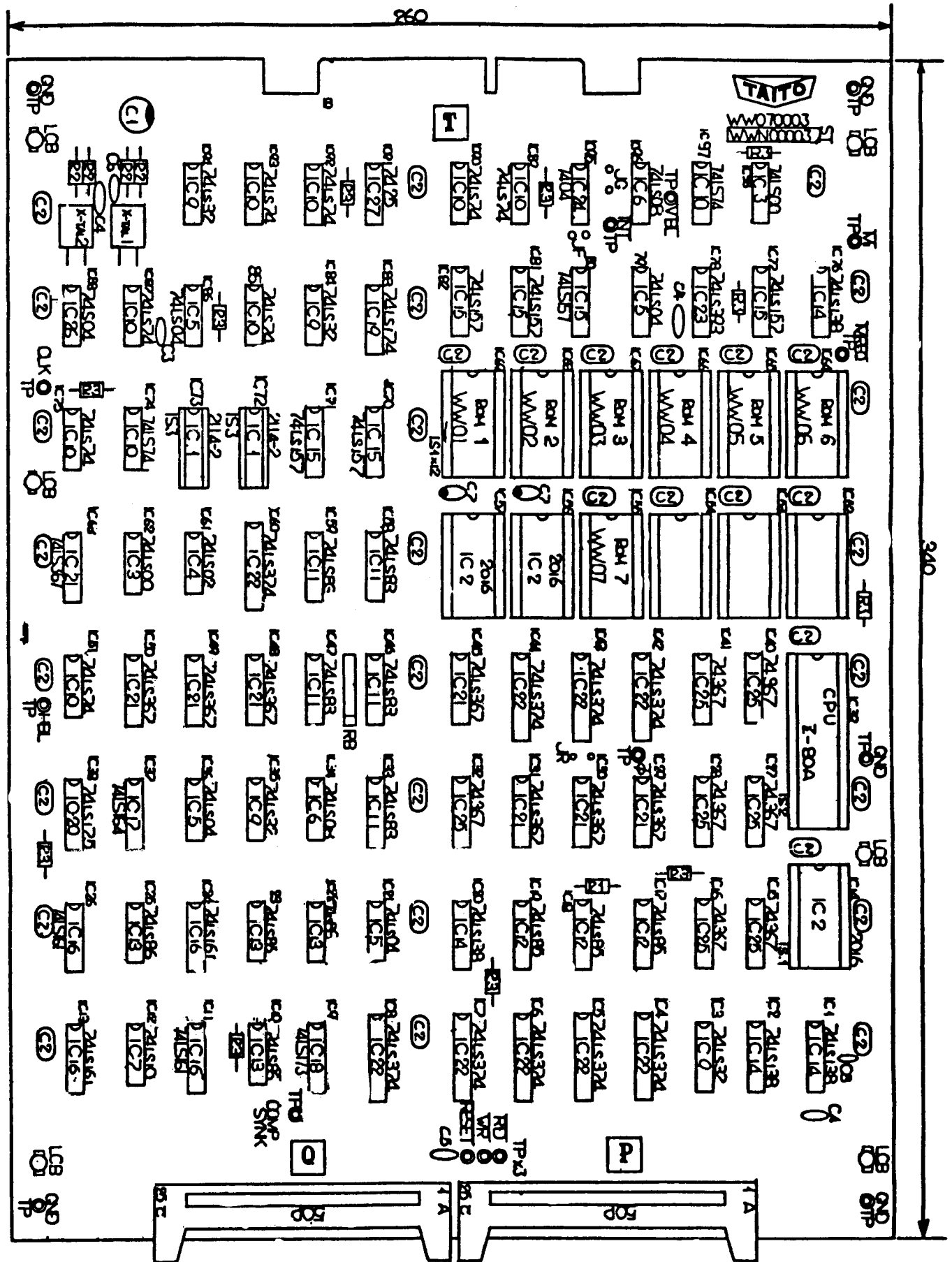

VIDEO BOARD

FIGURE 20

ITEM	SYM	TAITO PART NO.	DESCRIPTION
1		99-WW070002	VIDEO PC BOARD
2		NOT USED	
3	FRC	99-AAS00262	FRC HARNESS ASSY 50P
4	IS1	99-AA055103	IC SOCKET 18P
5	IS2	99-AA055786	IC SOCKET 16P
6	IS3	99-AA055787	IC SOCKET 24P
7	IS4	99-AA055999	IC SOCKET 22P
8	TP	99-AA056551	TEST POINT CHIP
9	CB	99-AA069589	LOCKING CIRCUIT BOARD SUPPORT
10	IC1	99-AAT32163	STATIC RAM 2114-2
11	IC2	99-AAT32178	STATIC RAM TMM2016P
12	IC3	99-AAT32180	TTL-RAM 93422
13	IC4	99-AAT33001	LS-IC 74LS00
14	IC5	99-AAT33003	LS-IC 74LS02
15	IC6	99-AAT33005	LS-IC 74LS04
16	IC7	99-AAT33009	LS-IC 74LS08
17	IC8	99-AAT33011	LS-IC 74LS10
18	IC9	99-AAT33019	LS-IC 74LS20
19	IC10	99-AAT33024	LS-IC 74LS27
20	IC11	99-AAT33026	LS-IC 74LS30
21	IC12	99-AAT33027	LS-IC 74LS32
22	IC13	99-AAT33051	LS-IC 74LS74
23	IC14	99-AAT33059	LS-IC 74LS83
24	IC15	99-AAT33062	LS-IC 74LS86

ITEM	SYM	TAITO PART NO.	DESCRIPTION
25	IC16	99-AAT33097	LS-IC 74LS139
26	IC17	99-AAT33108	LS-IC 74LS153
27	IC18	99-AAT33112	LS-IC 74LS157
28	IC19	99-AAT33118	LS-IC 74LS163
29	IC20	99-AAT33119	LS-IC 74LS164
30	IC21	99-AAT33121	LS-IC 74LS166
31	IC22	99-AAT33127	LS-IC 74LS174
32	IC23	99-AAT33128	LS-IC 74LS175
33	IC24	99-AAT33163	LS-IC 74LS253
34	IC25	99-AAT33170	LS-IC 74LS273
35	IC26	99-AAT33203	LS-IC 74LS367
36	IC27	99-AAT33209	LS-IC 74LS374
37	IC28	99-AAT32099	LS-IC 74LS367
38	ROM	99-AAT90417	ROM (745287) WW17
39			NOT USED
40	C1	99-AAT41023	CAP, ELECTROLYTIC 16VB220
41	C2	99-AAT41244	CAP, FILM TDY-1H-104
42	C3	99-AAT41324	CAP, CERAMIC DT-203-180P
43	C4	99-AAT41436	CAP, TANTALUM SSG35-1F
44	R1	99-AAT51757	RES, CARBON 470 OHM 1/4W 5%
45	R2	99-AAT51765	RES, CARBON 1 OHM 1/4W 5%
46	RB	99-AAT55036	RES BLOCK 1K OHM 8 ELEMENTS
47	ST	99-WW070202	P C BOARD STICKER WWN00002
48	C5	99-AAT41318	CAP, CERAMIC DT20 100P

GAME BOARD

FIGURE 21

ITEM	SYM	TAITO PART NO.	DESCRIPTION
1		99-WW070001	GAME PCB
2	IS5	99-AA055103	IC SOCKET 18P
3	DS	99-AA052566	DIP SWITCH
4	12P	99-AA055115	SL56 POST HEADER 12P
5	30P	99-AA055160	CONNECTOR PLUG HKP-30M
6	IS1	99-AA055169	IC SOCKET 28P
7	50P	99-AA055310	ANGLE PIN HEADER PS-50PA
8	IS2	99-AA055787	IC SOCKET 24P
9	IS3	99-AA055817	IC SOCKET 40P
10	IS4	99-AA055815	IC SOCKET 20P
11	TP	99-AA056551	TEST POINT
12	ICB	99-AA060557	LOCKING CIRCUIT BOARD SUPPORT
13	TR1	99-AAT11040	TRANSISTOR 25A423
14			PAN HO SCREW M3X6
15			NUT M3
16	TR7	99-AAT11070	TRANSISTOR 25D635
17			PAN HO SCREW
18			NUT M3
19	OP1	99-AAT31011	OP AMPLIFIER 1M3000
20	OP2	99-AAT31050	OP AMPLIFIER MR3230
21			PAN HO SCREW M3X8
22			NUT M3
23	IC1	99-AAT32033	TTL-IC 7416
24	IC2	99-AAT32049	TTL-IC 7417
25	IC3	99-AAT32163	STATIC RAM 2114.2
26	IC4	99-AAT32165	SOUND IC AY38910
27	IC5	99-AAT32179	TTL - RAM 93410
28	IC6	99-AAT33001	LS-IC 74LS00
29	IC7	99-AAT33003	LS-IC 74LS02
30	IC8	99-AAT33005	LS-IC 74LS04
31	IC9	99-AAT33008	LS-IC 74LS08
32	IC10	99-AAT33027	TI (ONLY) 74LS37
33	IC11	99-AAT33051	LS-IC 74LS74
34	IC12	99-AAT33020	LS-IC 74LS96
35	IC13	99-AAT33096	LS-IC 74LS138
36	IC14	99-AAT33097	LS-IC 74LS139
37	IC15	99-AAT33108	LS-IC 74LS153
38	IC16	99-AAT33110	LS-IC 74LS155
39	IC17	99-AAT33163	LS-IC 74LS253
40	IC18	99-AAT33164	LS-IC 74LS257
41	IC19	99-AAT33166	LS-IC 74LS259
42	IC20	99-AAT33127	LS-IC 74LS174
43	IC21	99-AAT33203	LS-IC 74LS367
44	IC22	99-AAT33209	LS-IC 74LS374
45	IC23	99-AAT33220	LS-IC 74LS393
46	CPU	99-AAT34008	CPU Z-80A
47	IC24	99-AAT36105	CMOS MB14584

ITEM	SYM	TAITO PART NO.	DESCRIPTION
48			NOT USED
49	IC26	99-AAT32099	TTL IC 74367
50	IC27	99-AAT32019	TTL IC 7404
51	IC28	99-AAT32011	TTL IC 7474
52	IC29	99-AAT32151	TTL IC 74273
53			NOT USED
54	C1	99-AAT41019	CAP, ELECTROLYTIC 16VB220 MF
55	C2	99-AAT41023	CAP, ELECTROLYTIC 16VB220
56	C3	99-AAT41238	CAP, FILM TDY-1M-103
57	C4	99-AAT41740	CAP, FILM TDY-1H-223
58	C5	99-AAT41244	CAP, FILM TDY-1H-104
59	C6	99-AAT41310	CAP, CERAMIC 47PF 50V
60	C7	99-AAT41242	CAP, FILM
61	C8	99-AAT41322	CAP, CERAMIC 150PF 50V
62	C9	99-AAT41374	CAP, CERAMIC 180PF 50V
63	C10	99-AAT41321	CAP, CERAMIC 22pf 50V
64	C11	99-AAT41334	CAP, CERAMIC 470PF 50V
65	C12	99-AAT41430	CAP, TANTALUM SSG25-10F
66	C13	99-AAT41431	CAP, TANTALUM SSG25-0R1F
67	C14	99-AAT41436	CAP, TANTALUM SSG35-1F
68	C15	99-AAT41432	CAP, TANTALUM SSG35 7R2F
69	R1	99-AAT51741	RES, CARBON 100 OHM 1/4W 5%
70	R2	99-AAT51761	RES, CARBON 680 OHM 1/4W 5%
71	R3	99-AAT51751	RES, CARBON 270 OHM 1/4W 5%
72	R4	99-AAT51753	RES, CARBON 330 OHM 1/4W 5%
73			NOT USED
74	R6	99-AAT51757	RES, CARBON 470 OHM 1/4W 5%
75	R7	99-AAT51765	RES, CARBON 1K
76	R8	99-AAT51779	RES, CARBON 3.9K 1/4W 5%
77	R9	99-AAT51781	RES, CARBON 4.7K OHM 1/4W 5%
78	R10	99-AAT51789	RES, CARBON 10K 1/4W 5%
79	R11	99-AAT51796	RES, CARBON 20K OHM 1/4W 5%
80	R12	99-AAT51797	RES, CARBON 22K OHM 1/4W 5%
81	R13	99-AAT51803	RES, CARBON 39K OHM 1/4W 5%
82	R14	99-AAT51775	RES, CARBON 82K OHM 1/4W 5%
83	R15	99-AAT51811	RES, CARBON 82K OHM 1/4W 5%
84	R16	99-AAT51812	RES, CARBON 100K 1/4 W 5%
85	R17	99-AAT51823	RES, CARBON 270K 1/4W 5%
86	R18	99-AAT51825	RES, CARBON 330K 1/4W 5%
87	R19	99-AAT51827	RES, CARBON 390K 1/4 W 5%
88	R20	99-AAT51829	RES, CARBON 470K 1/4W 5%
89	R21	99-AAT51833	RES, CARBON 680K 1/4 W 5%
90	R22	99-AAT51837	RES, CARBON 1M OHM 1/4W 5%
91	R23	99-AAT51733	RES, CARBON 47 OHM 1/4W 5%
92			NOT USED
93	R25	99-AAT51845	RES, CARBON 22M OHM 1/4W 5%
94			NOT USED

GAME BOARD**FIGURE 21**

ITEM	SYM	TAITO PART NO.	DESCRIPTION
95			NOT USED
96	R28	99-AAT51068	RES, CARBON 15 OHM ¼W 5%
97	R29	99-AAT51969	RES, CARBON 30K OHM ¼W 5%
98	R30	99-AAT51971	RES, CARBON 1M OHM ¼W 5%
99	R31	99-AAT51982	RES, CARBON 1 OHM ¼W 5%
100	VR	99-AAT53041	RES, VARIABLE RESISTOR B-50K
101	RB1	99-AAT55036	RES, BLOCK 1K OHM 8 ELEMENTS
102	RB2	99-AAT55061	RES, BLOCK 10K½00 OHM 8 ELEMENTS
109	R32	99-AAT55033	WINDING RES 6 OHM 2W 10%
108	D	99-AAT12007	DIODE V03C
104	ZD1	99-AAT13025	FENNER DIODE RD4.7EC
105	ZD2	99-AAT13042	FENNER DIODE RD2 7FBF
106	ZD3	99-AAT13028	FENNER DIODE RD9A-M
107	ST	99-EE070004	HARNESS STICKER
108			NOT USED
110	X-TAL	99-AA069593	X-TAL .6MHz
111	ROM 1	99-WW090414	PROM (2732) WW14
112	ROM 2	99-WW090415	ROM WW15
113	ROM 3	99-WW090416	ROM WW16

GAME BOARD COMPONENT LAYOUT

FIGURE 21

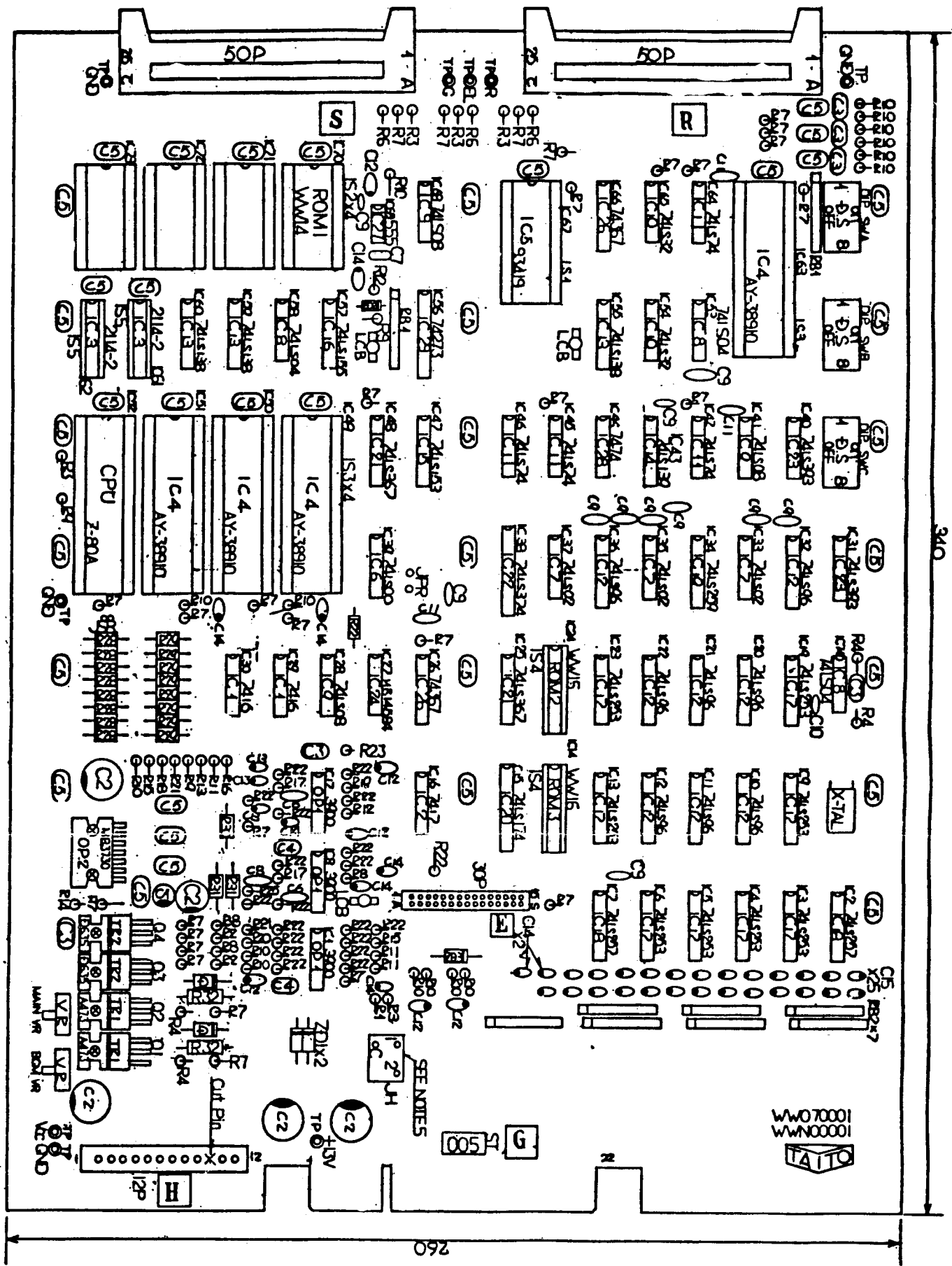

ROM PC BOARD SCHEMATIC 1 of 1

FIGURE 23

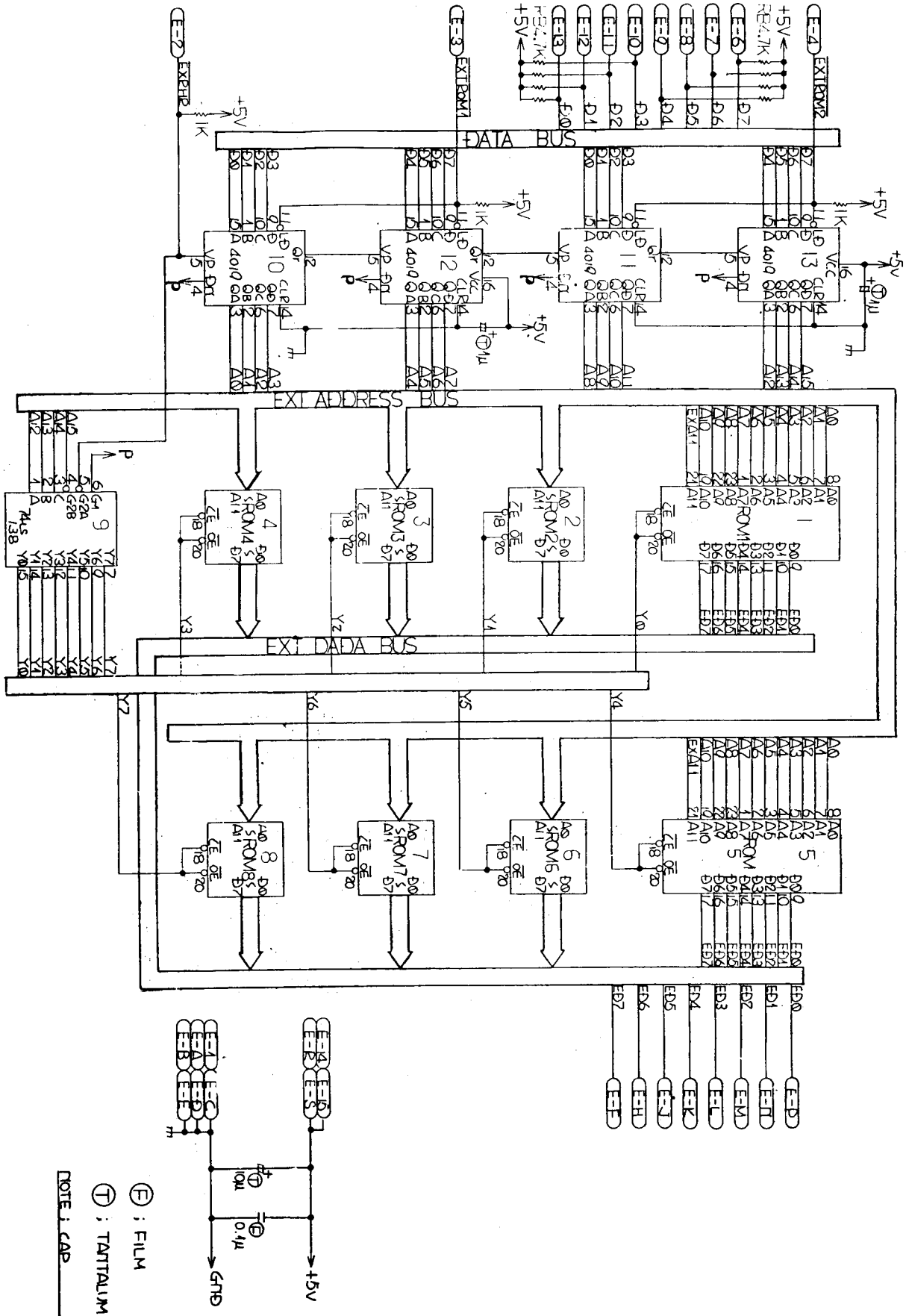

CPU PC BOARD SCHEMATIC 1 of 3

FIGURE 24

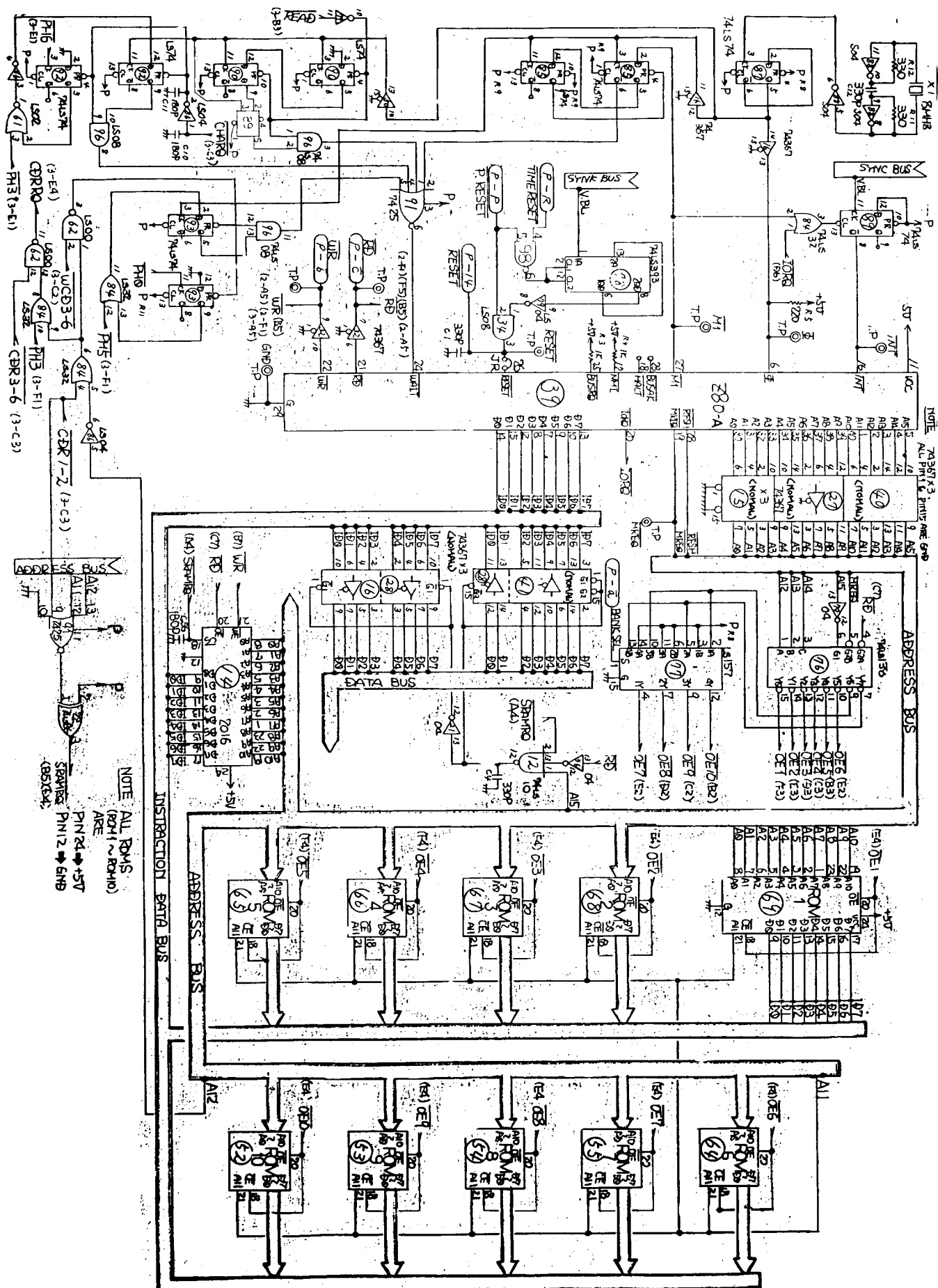

CPU PC BOARD SCHEMATIC 2 of 3

FIGURE 25

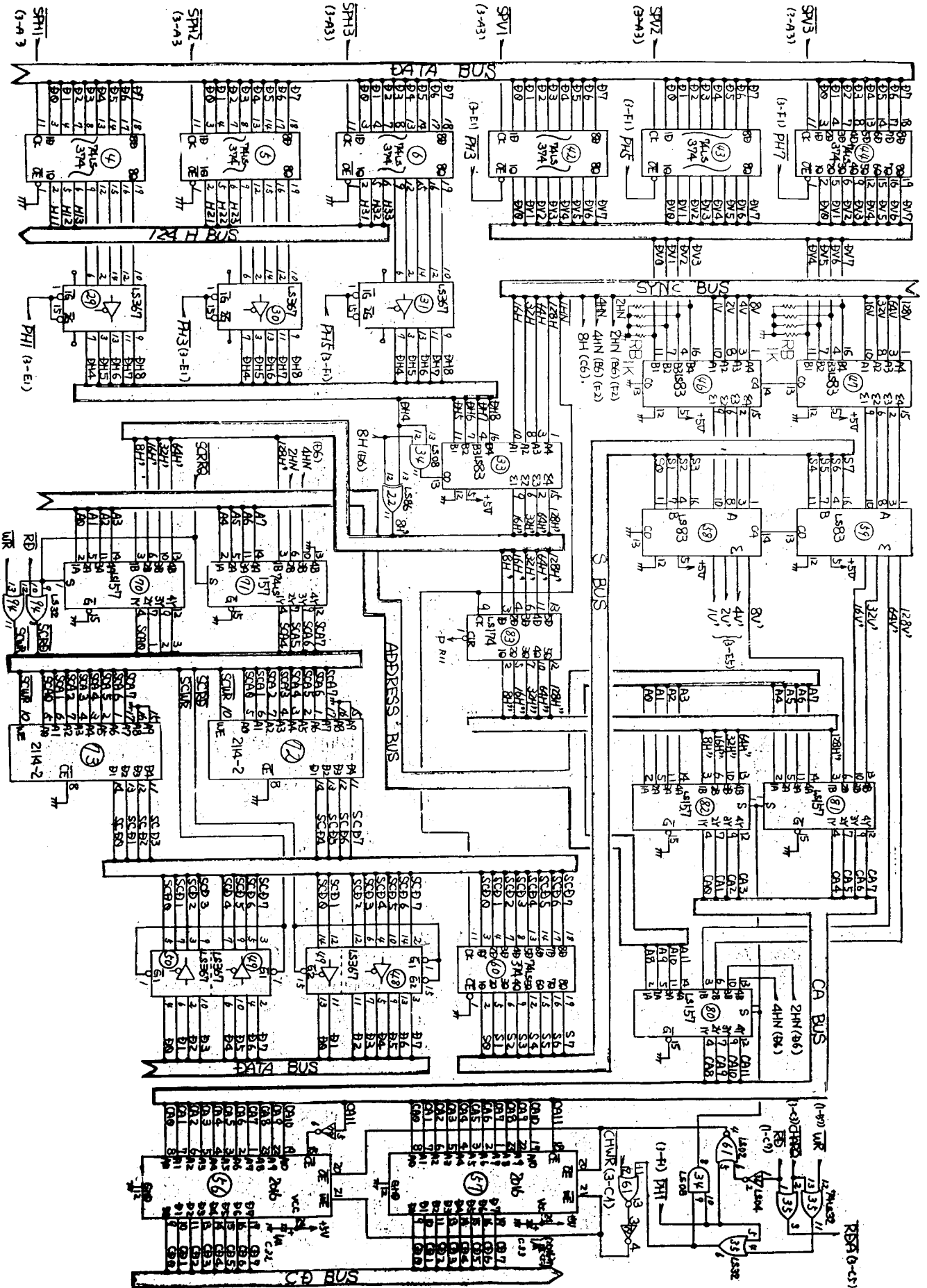

CPU PC BOARD SCHEMATIC 3 of 3

FIGURE 26

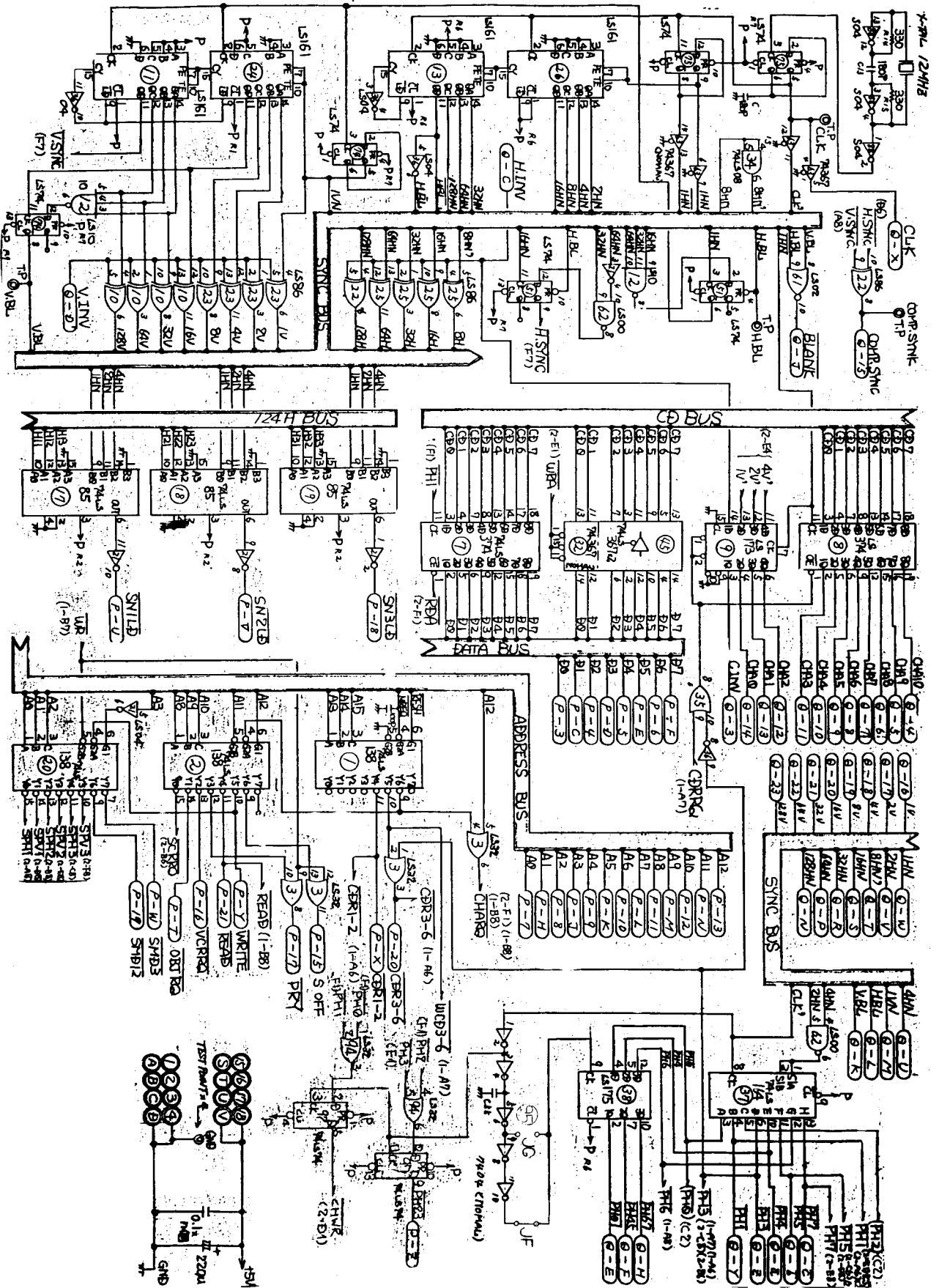

VIDEO PC BOARD SCHEMATIC 1 of 5

FIGURE 27

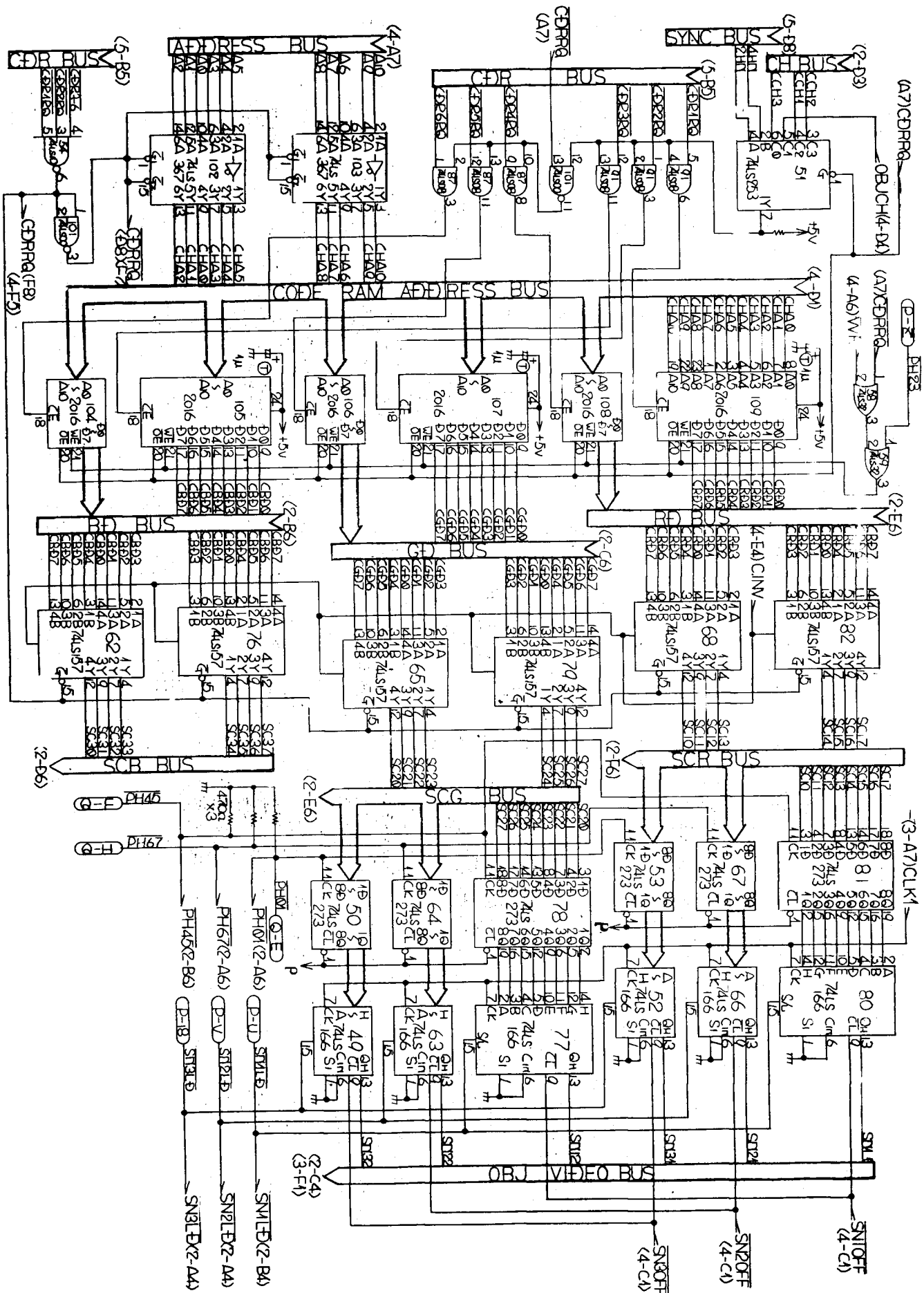

VIDEO PC BOARD SCHEMATIC 3 of 5

FIGURE 29

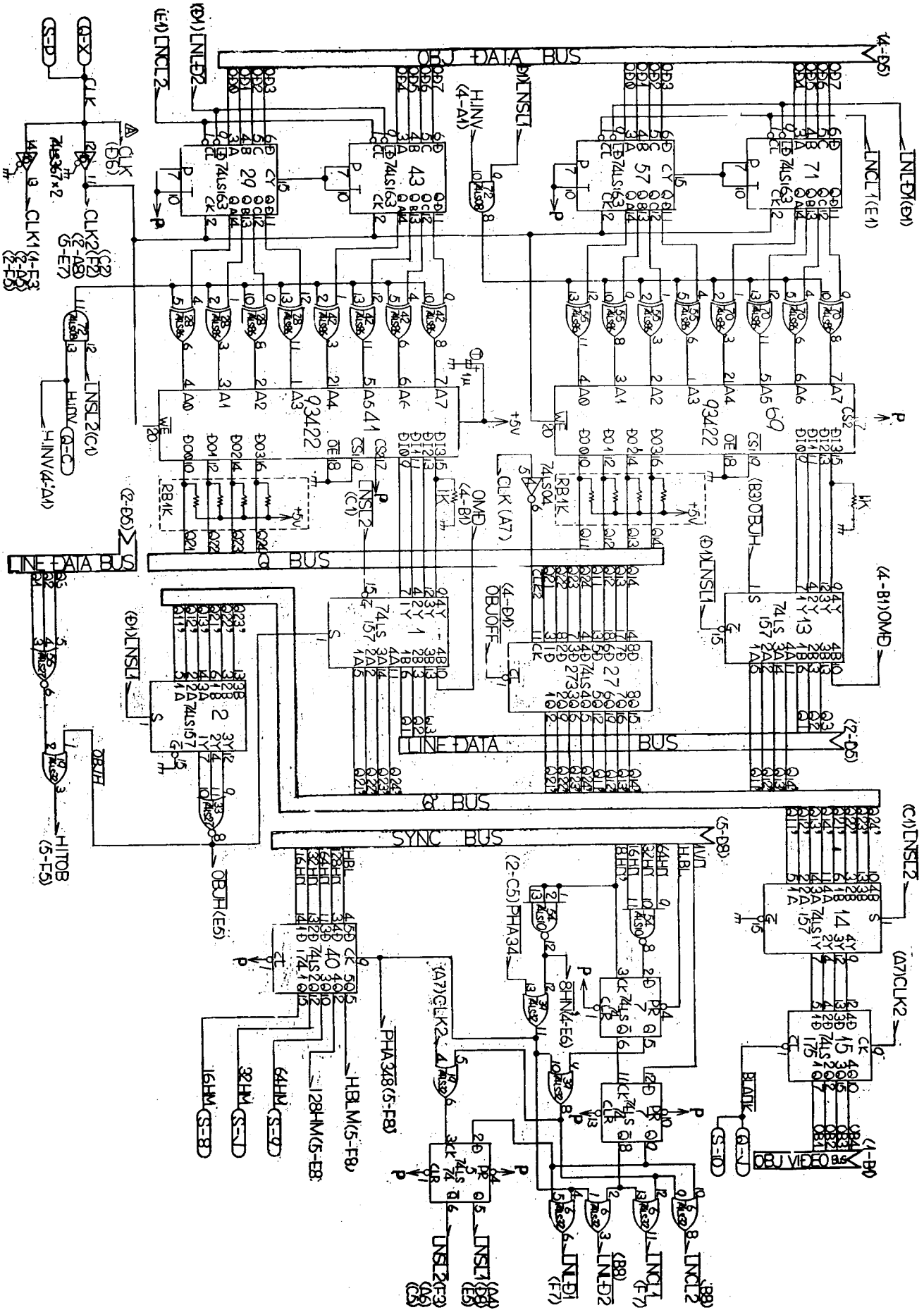

VIDEO PC BOARD SCHEMATIC 4 of 5

FIGURE 30

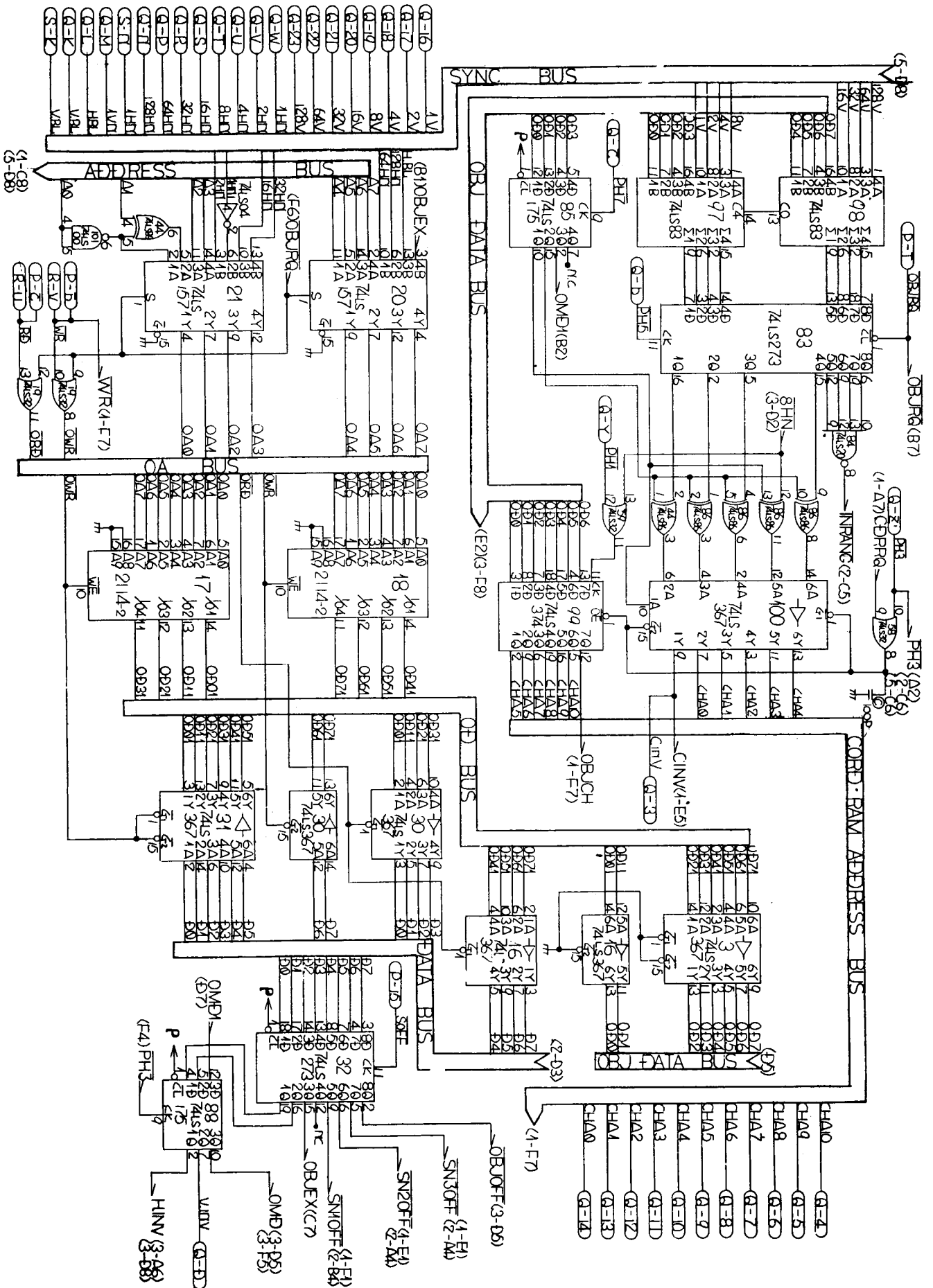

VIDEO PC BOARD SCHEMATIC 5 of 5

FIGURE 31

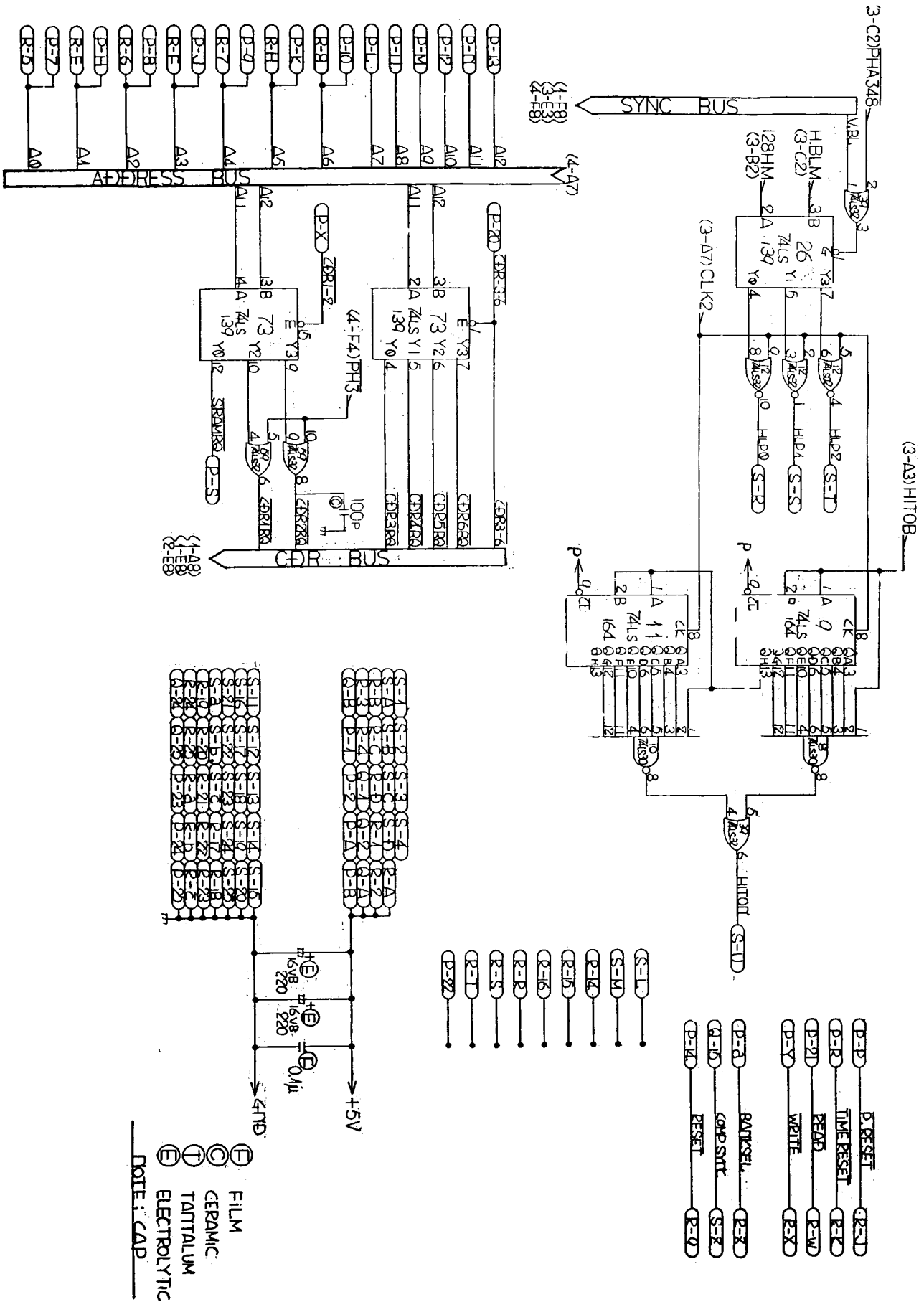

GAME PC BOARD SCHEMATIC 1 of 7

FIGURE 32

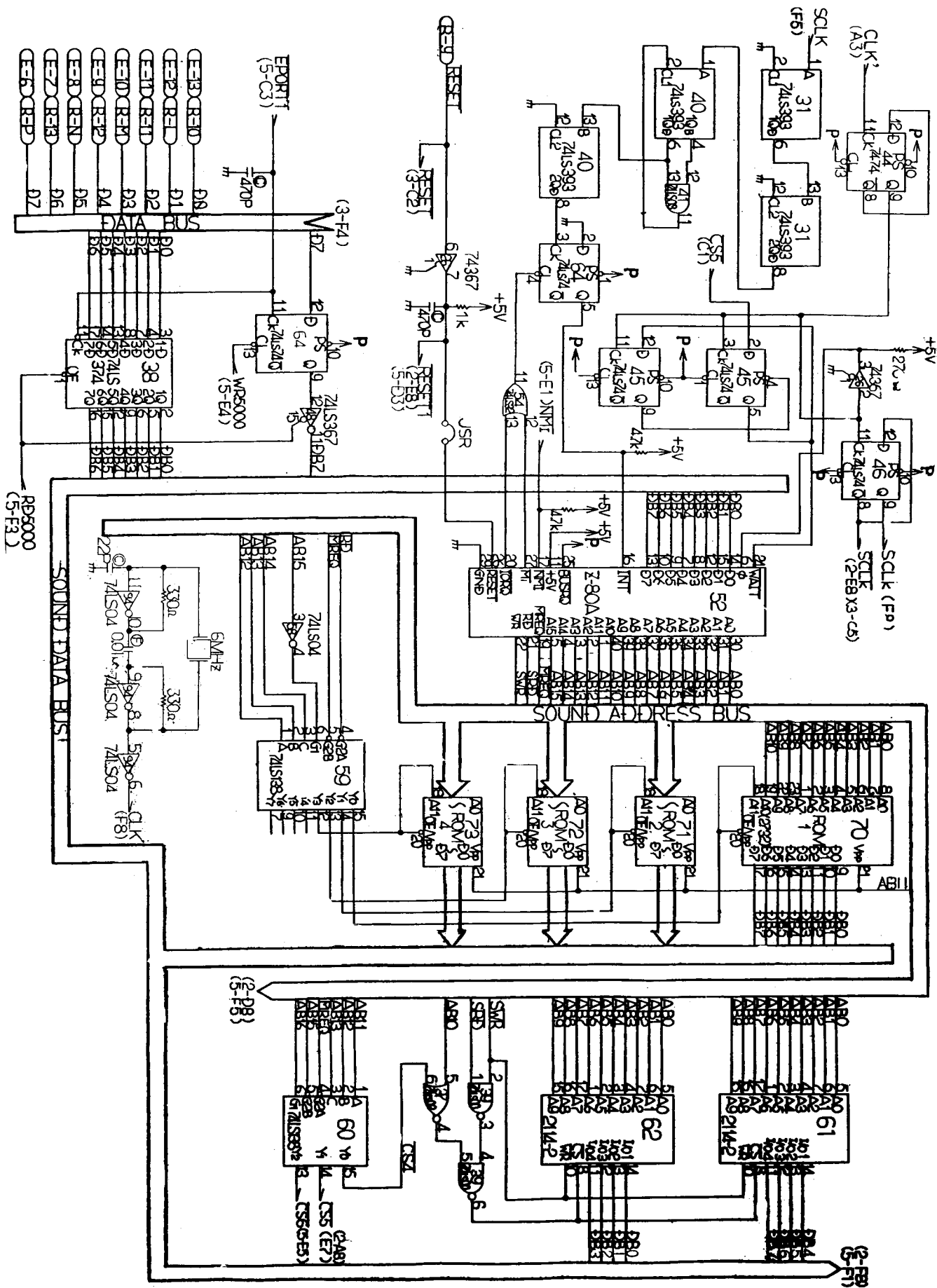

GAME PC BOARD SCHEMATIC 2 of 7

FIGURE 33

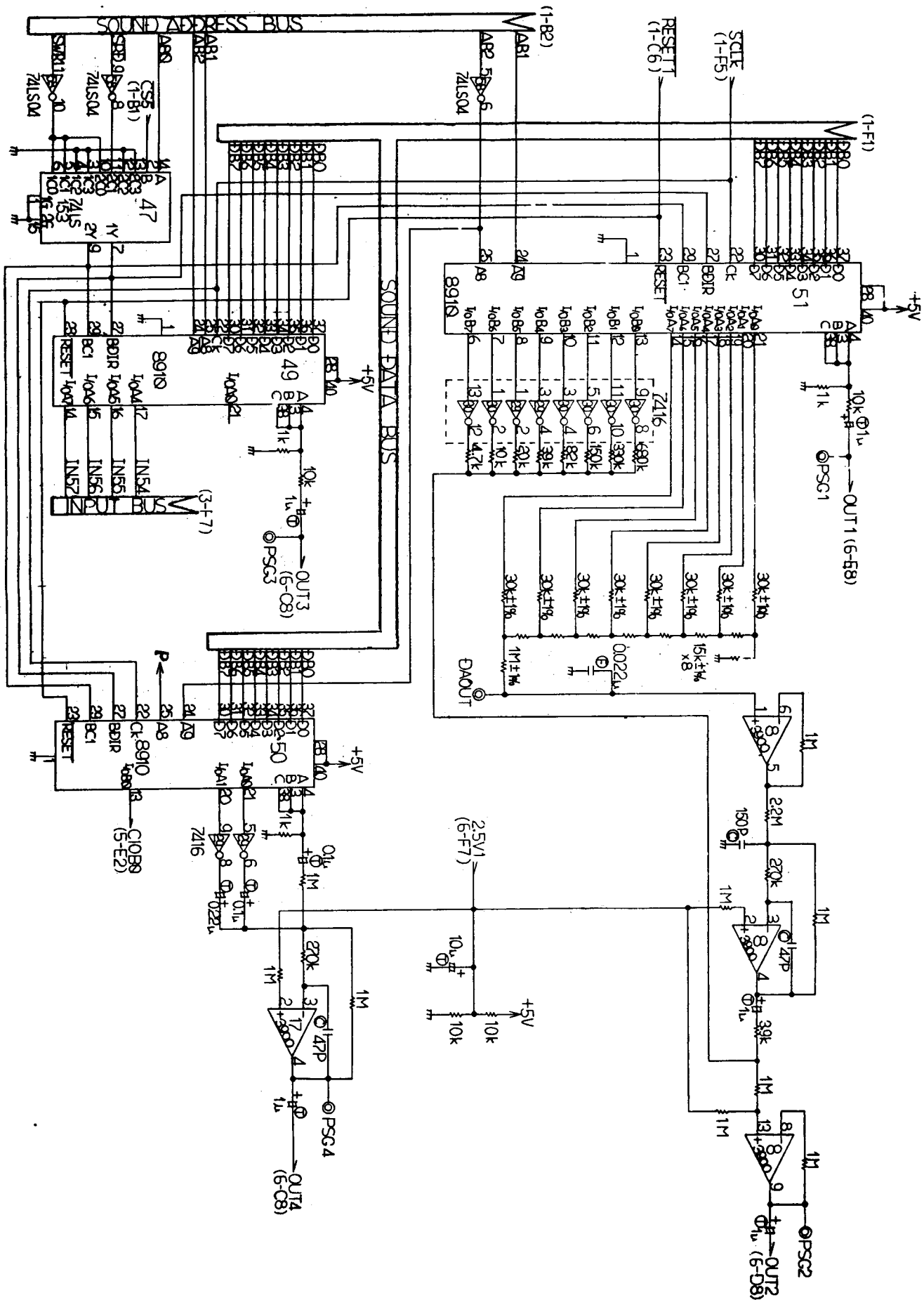

GAME PC BOARD SCHEMATIC 4 of 7

FIGURE 35

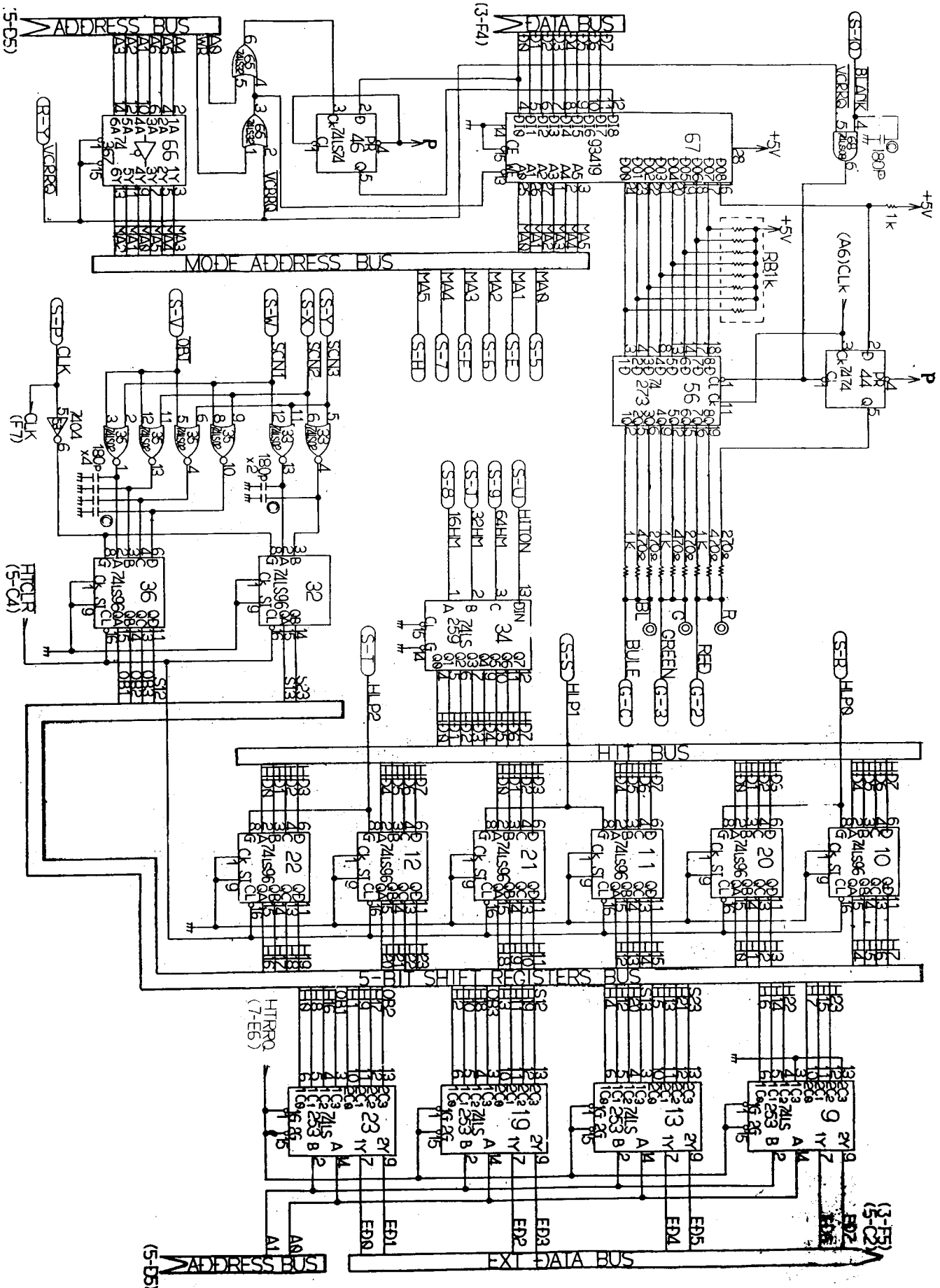

GAME PC BOARD SCHEMATIC 7 of 7

FIGURE 38

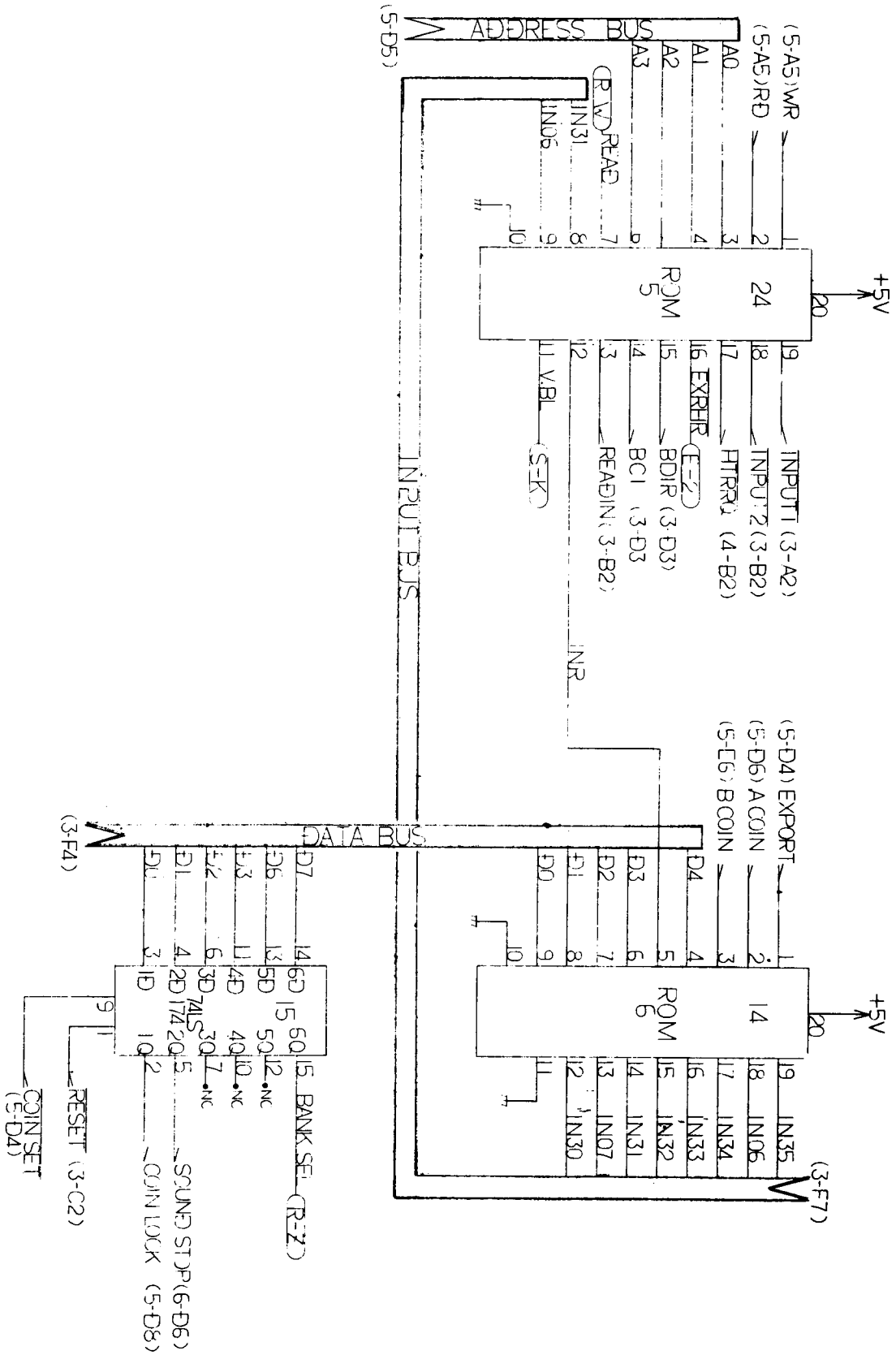



TAITO AMERICA CORPORATION

1256 Estes Avenue, Elk Grove Village, IL 60007
Telephone (312) 981-1000 Telex 25-3290