

ATARI[®] 2600[™]

CLIMBER 5



CLIMBER 5 © 2004 by Dennis Debro

NOTE: Always turn the console **POWER** switch **OFF** when inserting or removing an ATARI® Game Program™ cartridge. This will protect the electronic components and prolong the life of your ATARI 2600™ Video Computer System™ game.

©2004 DENNIS DEBRO, ALL RIGHTS RESERVED



TABLE OF CONTENTS

1. GAME PLAY	1
2. USING THE CONTROLLER	1
3. CONSOLE CONTROLS	2
4. GAME VARIATIONS	3
5. SCORING/BONUSES	4
6. STRATEGY	5
7. ACKNOWLEDGEMENTS	6
8. NOTES	7
9. YOUR BEST TIMES	8

1. GAME PLAY

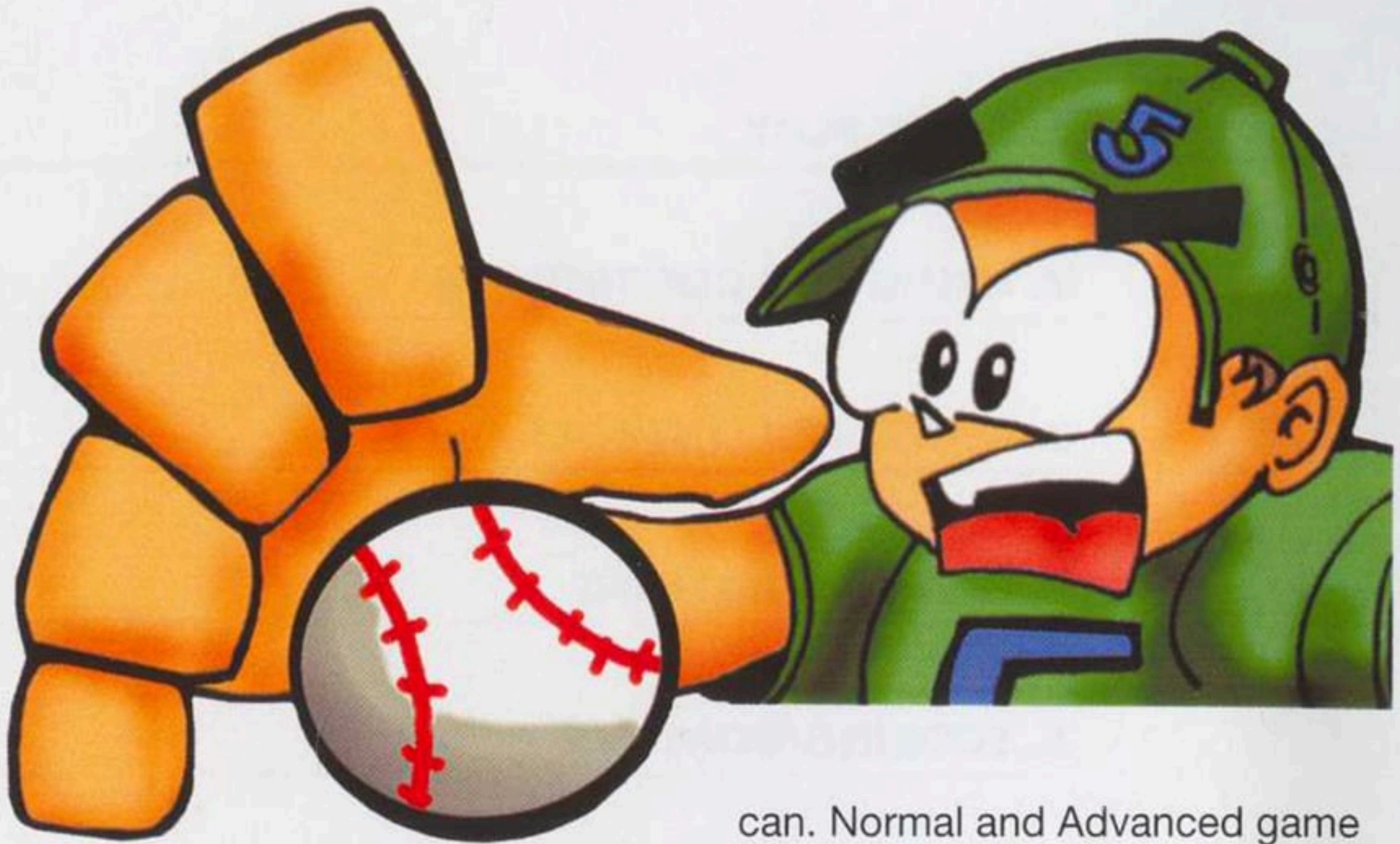

Your objective in CLIMBER 5 is to retrieve the baseball located on the construction site while avoiding the moving girders.

You are given three tries to retrieve as many baseballs as you possibly

can. Normal and Advanced game options award another try once 10,000 points has been reached.

With each level the girders increase in speed and your Climber's speed is reduced. The game continues in this fashion getting progressively more difficult.

2. USING THE CONTROLLER

Use your Joystick controller with this ATARI Game Program cartridge. Plug one Joystick firmly into the **LEFT CONTROLLER** jack at the back of your 2600 Video

Computer System console. Hold the Joystick with the red button pointing to your upper left, toward the television screen. (See your owner's manual for further details.)

CONTROLLER ACTION

Use your Joystick controller to maneuver your climber to retrieve the baseball. Your climber may move left or right while standing on a platform. Use the ladders provided to ascend/descend the construction site to retrieve the ball or to avoid girders. Just move the Joystick in the direction you want the climber to go.

NOTE: You cannot use the red button to interrupt a game and begin a new game. Use the **GAME RESET** switch for that purpose.

Press the red button to change the direction of the girders (Only in Normal and Advanced games.) The bonus timer is reduced by 500 units each time the red button is pressed, penalizing the player.

NOTE: During higher levels of the Advanced option this may be used to the player's advantage. In higher levels, the girders push falling obstacles. With good timing the player can use this to capture out-of-reach bonus items or to avoid dangerous items.

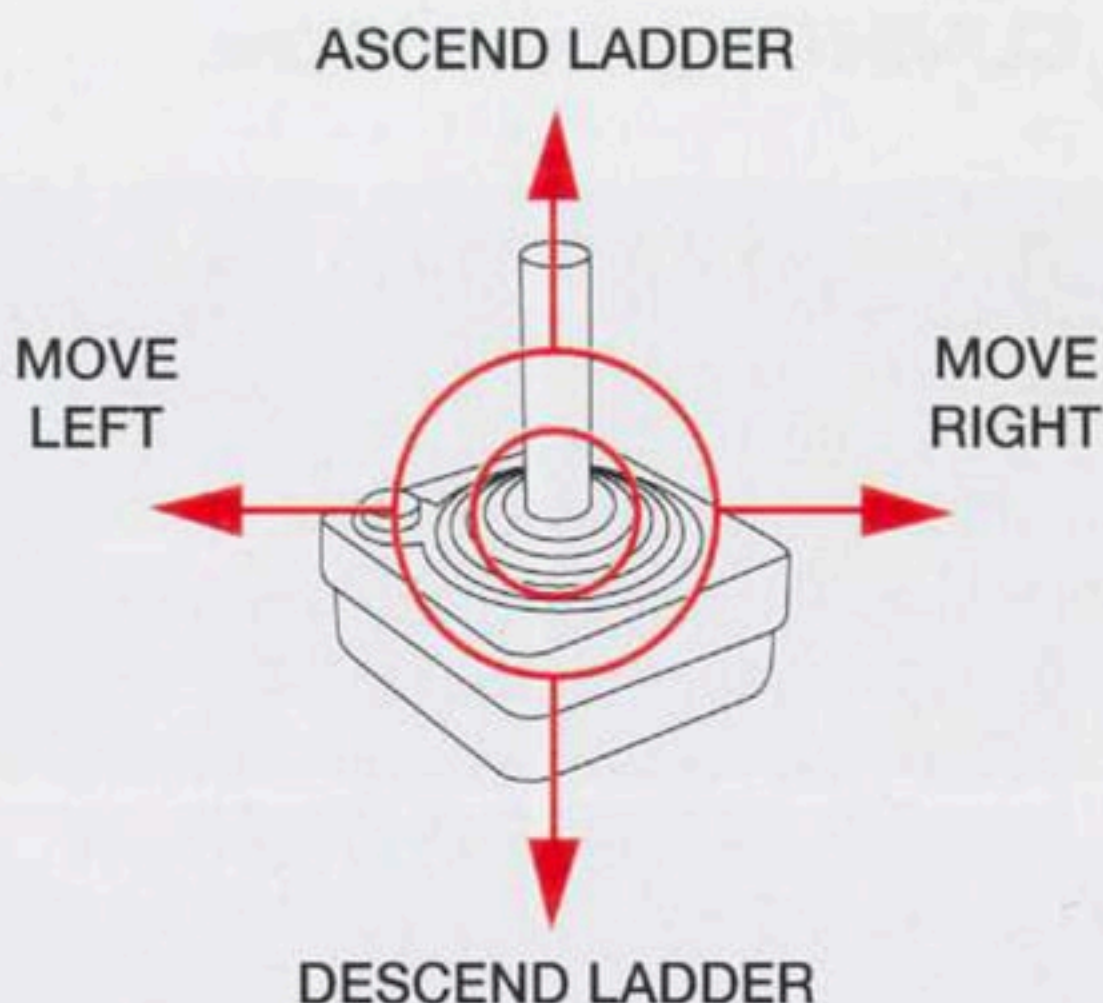

3. CONSOLE CONTROLS

TV TYPE SWITCH (PAUSE 7800)

This switch is used to pause the game action. 2600 users will need to toggle the switch back and forth to cause the game action to pause. 7800 users only need to press the **PAUSE** button

If the game has been paused for approximately 10 minutes, the

screen will black out to save the television from image burn. To resume play from the black out mode the player must wiggle the joystick.

To resume play 2600 users must toggle the **TV TYPE** switch. 7800 users only need to press the **PAUSE** button.

GAME RESET SWITCH

Use the **GAME RESET** switch to start the game, or to restart the game at any time during play. The red controller button can also be used to start a new game from the title screen.

GAME SELECT SWITCH

Use the **GAME SELECT** switch to toggle between the different CLIMBER 5 game variations.

DIFFICULTY SWITCHES

The **LEFT DIFFICULTY** switch is used only for Normal and Advanced game options.

EXPERT: Position A- the player is not warned before the girders change direction.

NOVICE: Position B- the girders flash to warn the player before they change directions.

4. GAME VARIATIONS

ORIGINAL:

This option mimics the original Atari 8-bit type in version as closely as I could execute. In this option the girders move from left to right trying to stop the climber from reaching the baseball at the top of the construction. There is no score and no extra tries are rewarded. See how many levels you can conquer.

NORMAL:

The ladder positions and the girder movements are random in this option. You begin the game with a timer bonus of 5000 that ticks down approximately every 2 seconds. Your goal is to reach the baseball before time runs out or the player loses a turn. The player

is awarded the remaining timer value as a score once the baseball has been retrieved. Move quickly...the baseball will change positions if you take too long.

ADVANCED:

This option is the same as the Normal option with the exception of falling obstacles. As the climber tries to retrieve the ball, various obstacles fall from the platforms above. Some of these obstacles are harmful to the climber (example: lunch box, brick, and hammer.) If a falling obstacle does touch the climber the player will lose a turn.

5. SCORING/BONUSES

A score is only awarded for game options Normal and Advanced.

Some obstacles will reward the player with points so keep your eyes peeled. To achieve high scores, try to catch these in the order of cup, teddy bear, butterfly, and the AtariAge logo.

These point values will increase every fifth level until the player reaches level 20. If the player retrieves an obstacle out of order they are rewarded the minimum point value and the sequence starts over.

CLIMBER 5  100 PTS	CUP  300 PTS	TEDDY BEAR  500 PTS	BUTTERFLY  700 PTS
AA LOGO  0 PTS	HAMMER  0 PTS	LUNCH BOX  0 PTS	BRICK  0 PTS

CLIMBER 5 BONUS TABLE

Extra Try At 10,000 PTS

Retrieving The Baseball Remaining Timer Value

NOTE: Each bonus item is worth 100PTS unless retrieved in a specific order!

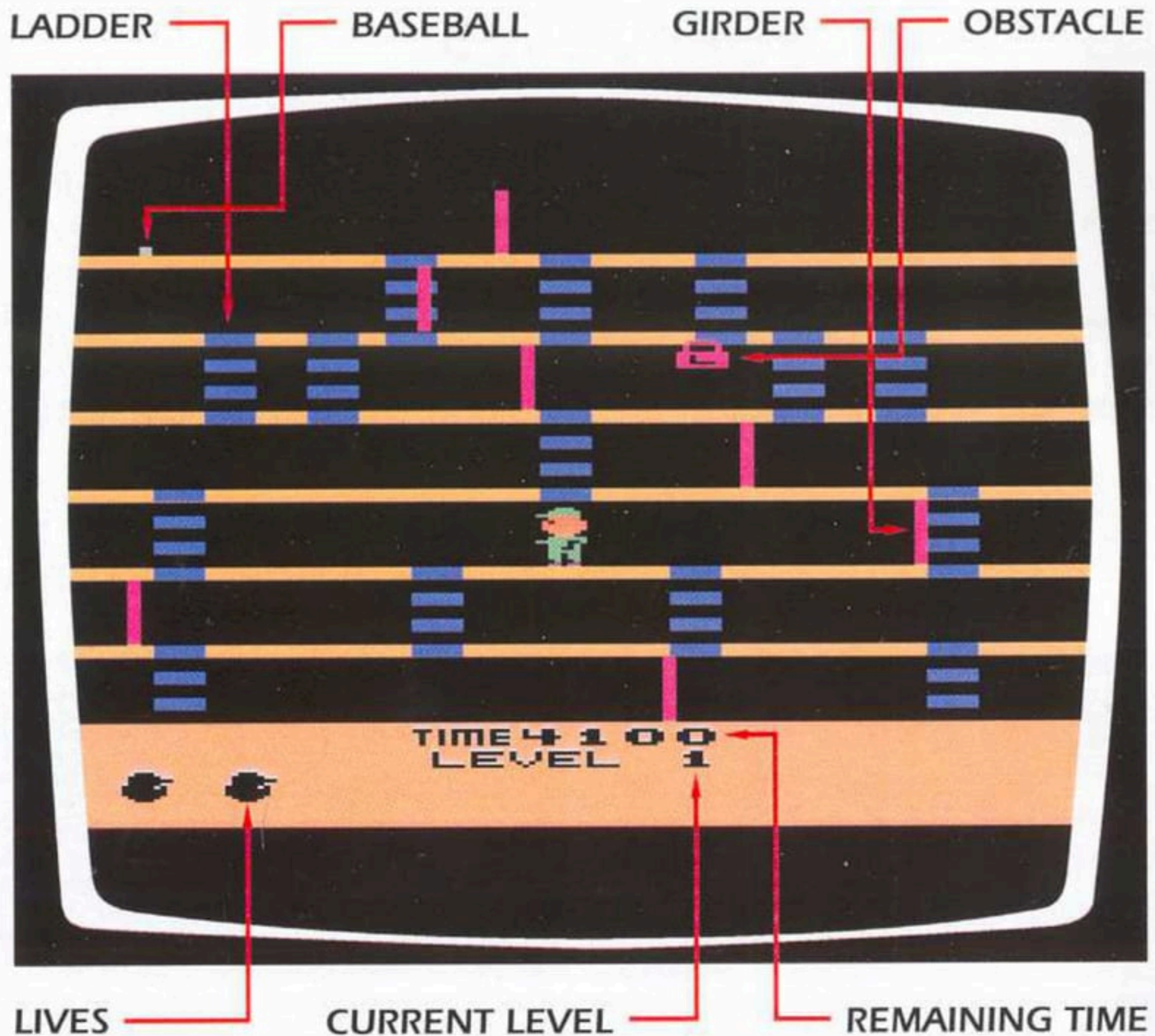

6. STRATEGY

ORIGINAL:

- The girders always move from left to right in this option. Once it passes it will continue to the right edge before coming back again.
- The Climber can climb a ladder while hanging off the left or right edge of the ladder. Keep this in mind for levels 5 and higher.

- You can get past levels 5 and higher...timing is the key.

NORMAL / ADVANCED:

- The girders don't make full use of the screen range before changing their direction. See if you can locate their "secret" zones when you need a little breather.

- Keep your eyes peeled for falling bonus items to watch your score increase rapidly.
- Try to use the red controller button to change girder direction

to your advantage. It can be a nice tool to push bonus items toward you or push harmful items away from you.

7. ACKNOWLEDGEMENTS

Here is a short list people that helped me along the way, in no particular order:

Peiro Cavina

CLIMBER 5 uses snippets from Peiro Cavina's PCMCD demo, with his permission, which later became Oystron. I couldn't have done this game without this code. Thank you Peiro!! Go to the AtariAge store for more information on this excellent game. If you don't own it, I suggest you buy it, it's a great game.

Dale Crum

Dale worked on the layout of the Climber 5 manual. His talents give the manual a feel that it was released back in the '80s. Thank you Dale!

Jason Dvorak

AtariAge hosted a label contest for the label art for Climber 5. Jason's work was outstanding! After winning the contest he went the extra mile and supplied the

wonderful comic strip in the manual. Thank you Jason!

Andrew Davie

Andrew, along with Thomas, knows how to squeeze every last byte out of 6502/7 assembler code. Andrew was instrumental in helping me reduce my first ROM image by over 190 bytes! Using these same techniques I was able to get more into CLIMBER 5 while still keeping it within my 4K ROM set limit. For the techies...you should see how Andrew clears the game RAM and sets the stack to the beginning-it's pure genius!

Thomas Jentzsch

Thomas has helped to improve CLIMBER 5 by showing code samples and unselfishly sharing source code to his 2600 works. Through his guidance I learned much about 2600 programming in the last 2 years. There were areas that I thought were impossible to do. Thomas pushed me to keep

adding more and ultimately showing me what I thought was impossible was possible.

Manuel Rotschkar

Manuel suggested the falling objects. This was probably the most frustrating thing to code, though the best aspect to the game play. The display kernel timings weren't coming out right but, I was able to pull it off though with help from Thomas. Manuel also made suggestions on improving the look of the game (graphics).

Albert Yarusso

Albert is a perfectionist and there was no way I was going to get a mediocre game past him. He gave

a lot of suggestions for improving the game that you see in the Normal and Advanced options; random girder movement, random ball placement and score.

Fabrizio Zavagli

I sent many PAL builds to Fab to test on his PAL system. He helped me make sure the PAL timings were equivalent or comparable to the NTSC timings.

Stella Mailing List and AtariAge Message Board Members

Thank you for all of your suggestions, support, encouragement, and bug testing. It was invaluable to the release of CLIMBER 5.

8. NOTES

CLIMBER 5 is based on an Atari 8-Bit public domain game of the same name. The original game was written by James Rogers and appeared in COMPUTE! magazine (Aug. 1987 - Vol. 9, No. 8, Iss. 87). My college roommate and I had hours of fun playing this game.

The CLIMBER 5 project started in the first quarter of 2002. I was originally planning on attending the CCAG (Classic Computer and

Gaming Show, Cleveland, Ohio) that year and it was going to be my first classic gaming event. A new hack based off of Fox's Futurama TV show was planned to be released at this event.

Unfortunately, the developer of the Futurama hack was contacted and asked not to release the game for legal reasons.

Being that this was going to be my

AtariAge Presents:

CLIMBER 5

Original Concept - James Rogers

Atari 2600 Game - Dennis Debro

Comic Version - Jason Dvorak



So yeah, I'm the ball boy.

It's not as glorious as
batting clean up, but
I'm still important
to the team.

I even have my lucky number 5
on my uniform.

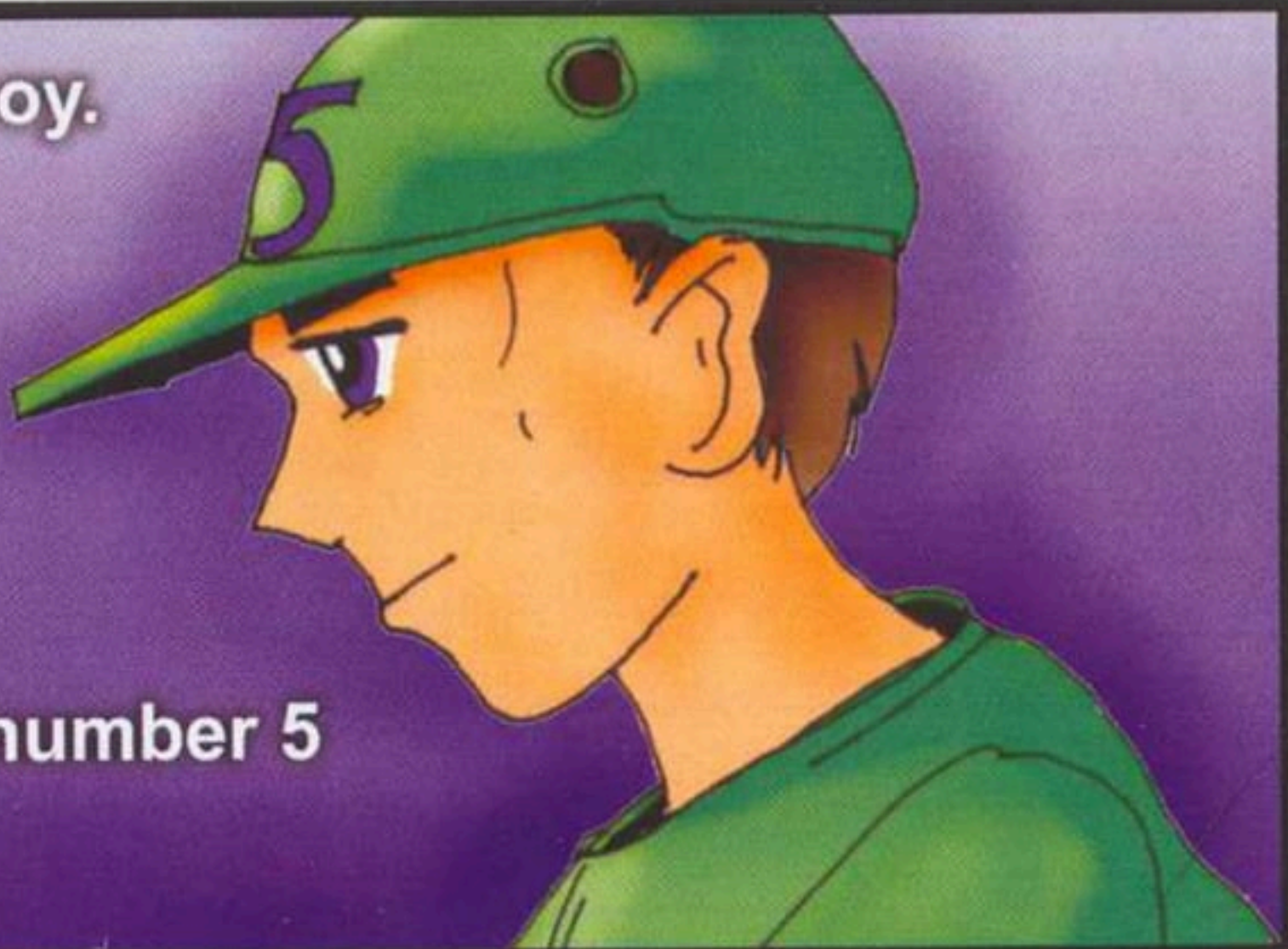

Lots of home runs
today. Right now
the visitors are
losing by four
with the bases
loaded.

Ump says we're
down to our last
baseball as well.



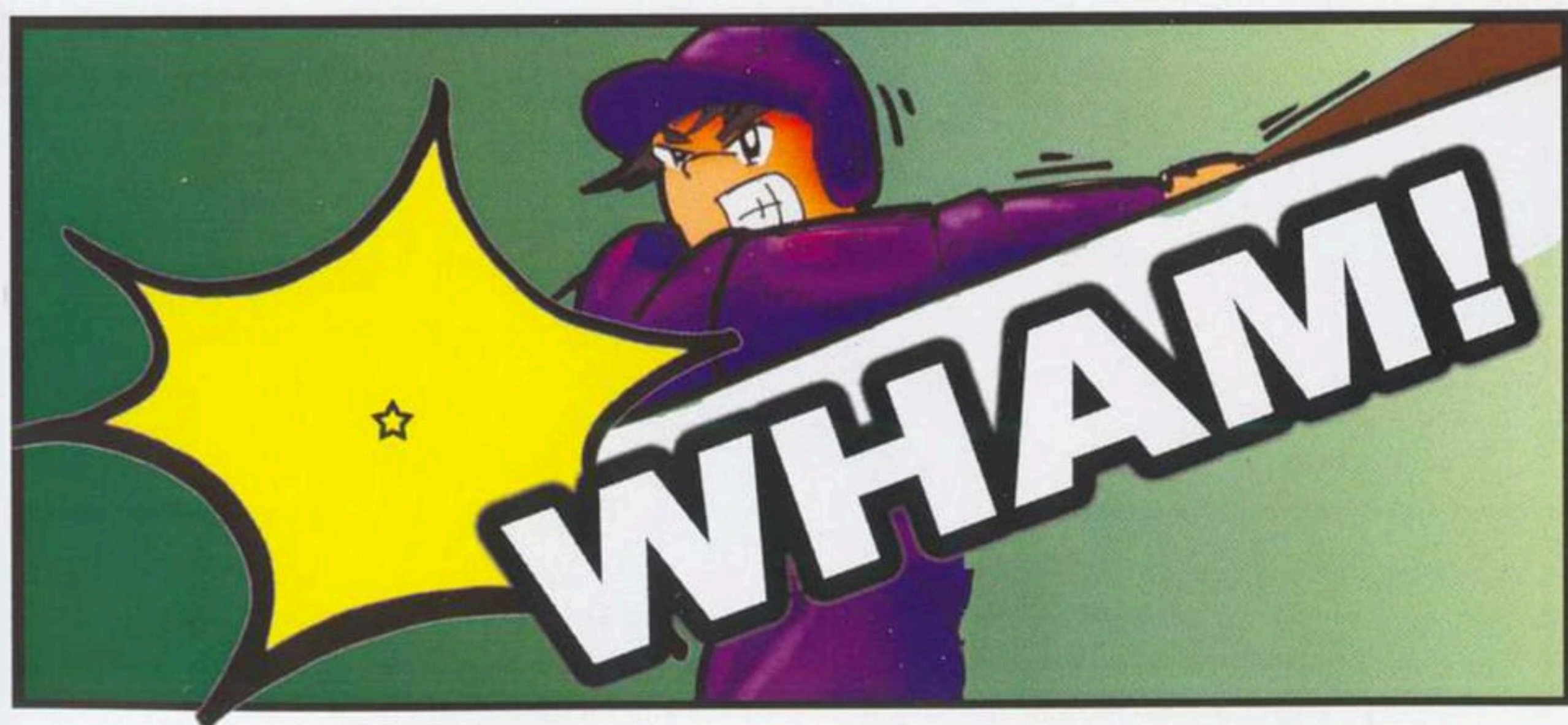
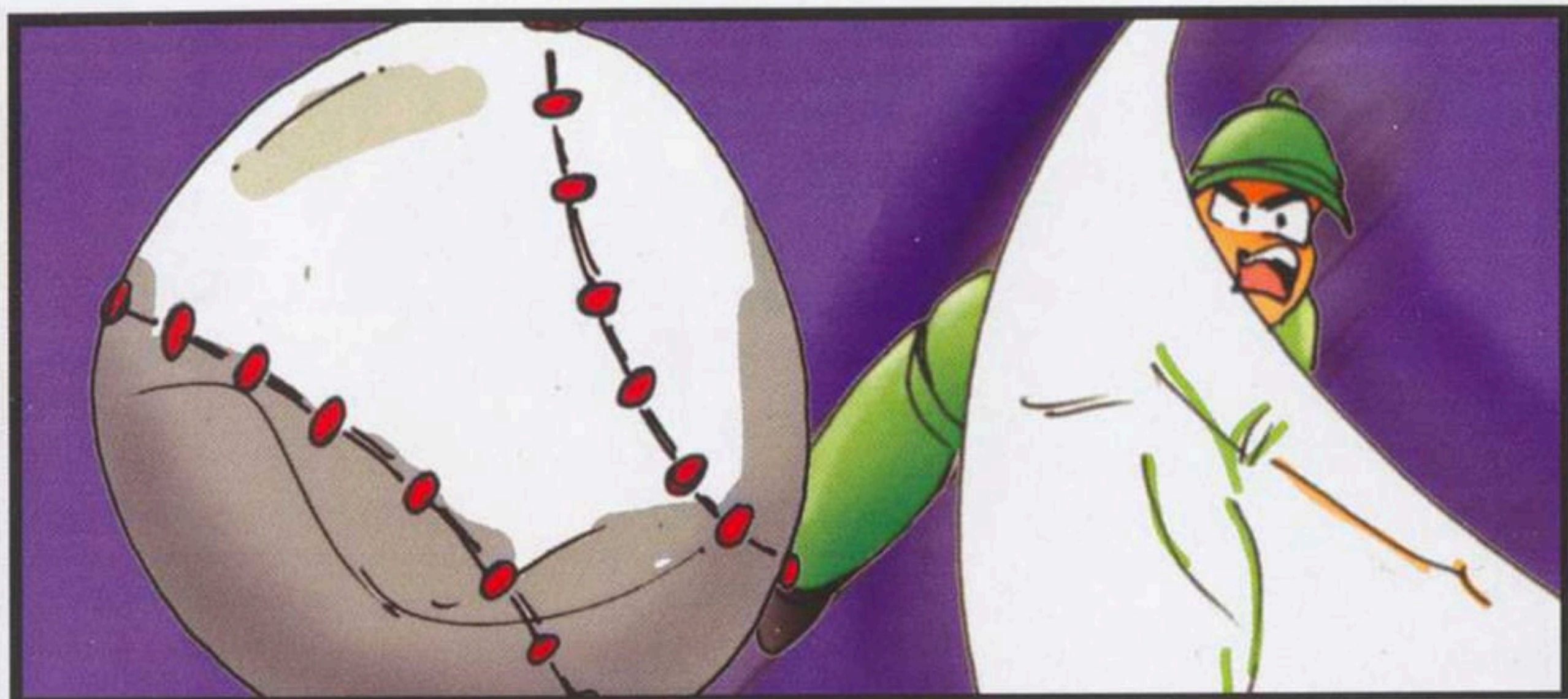
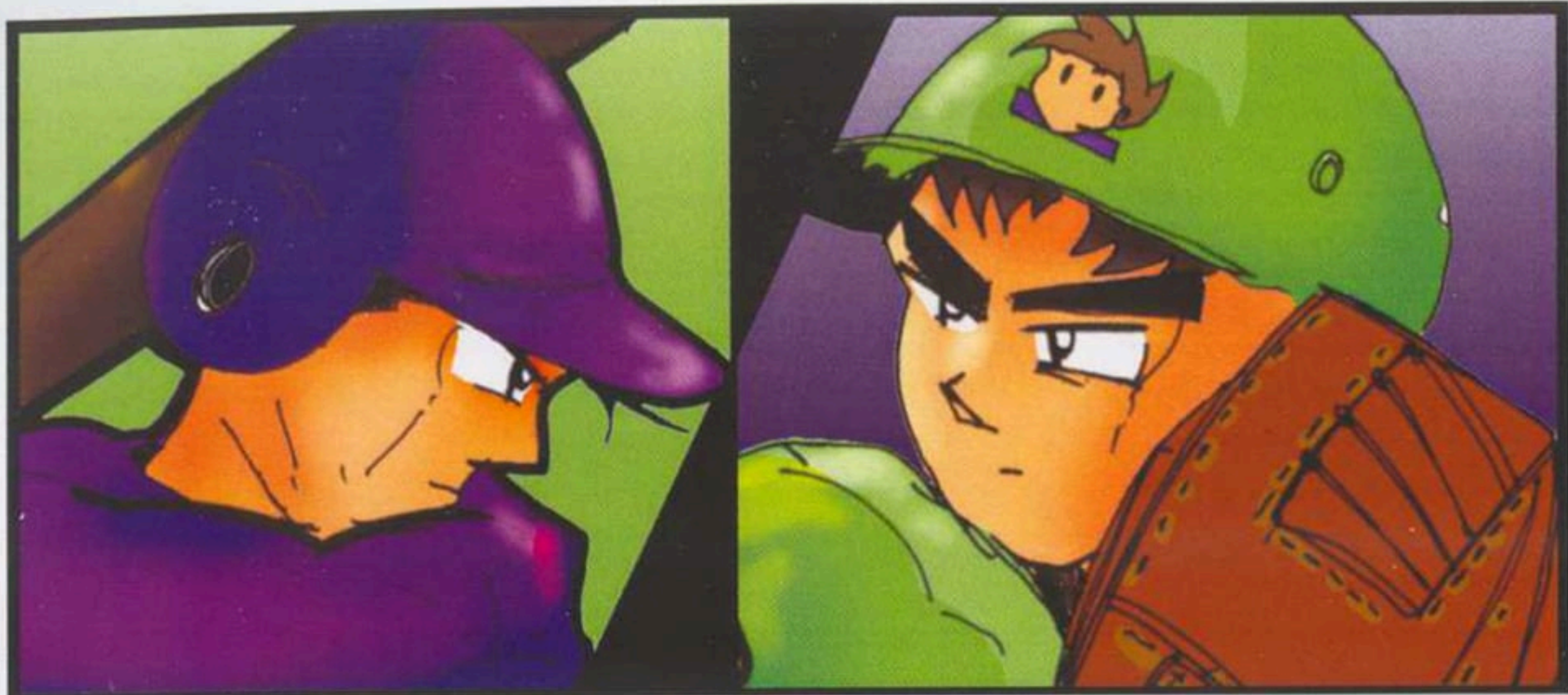

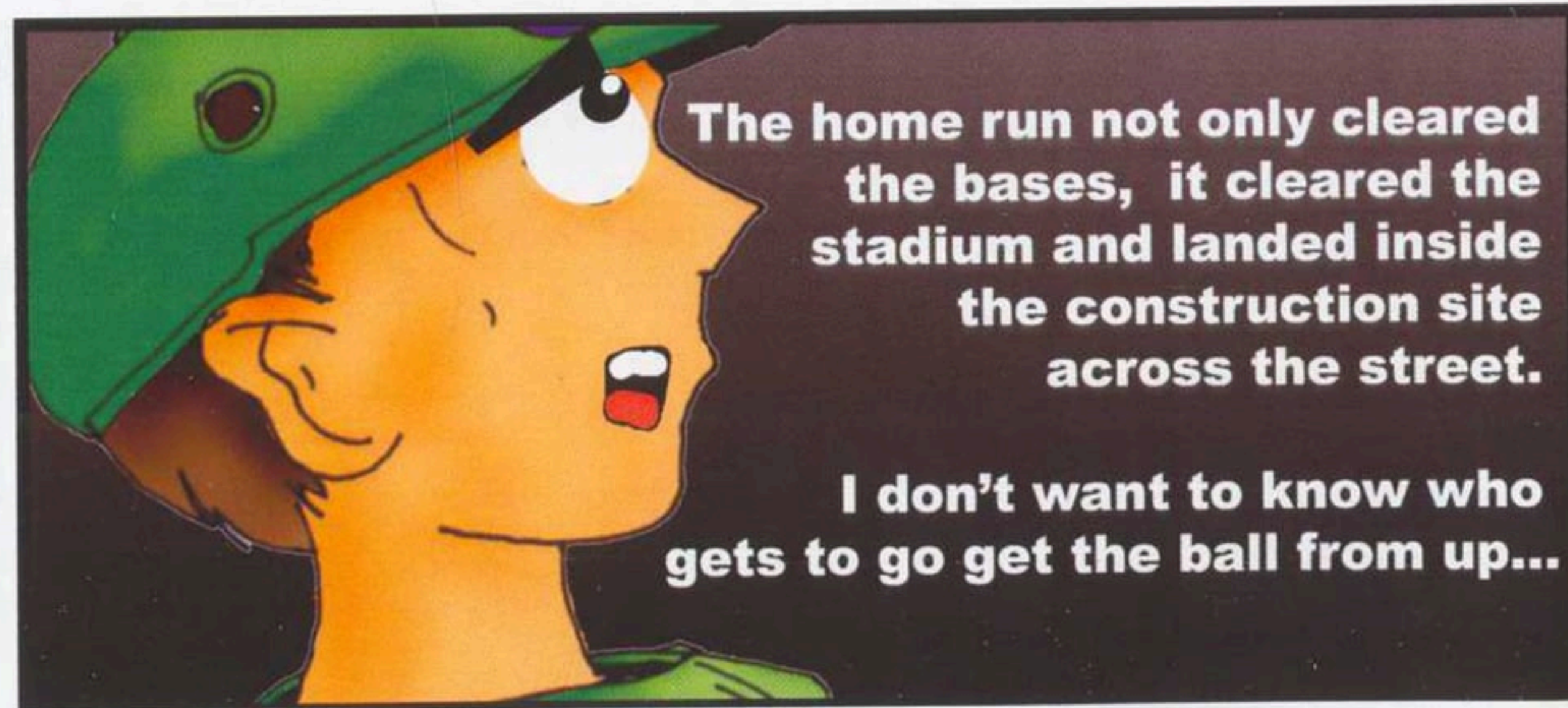
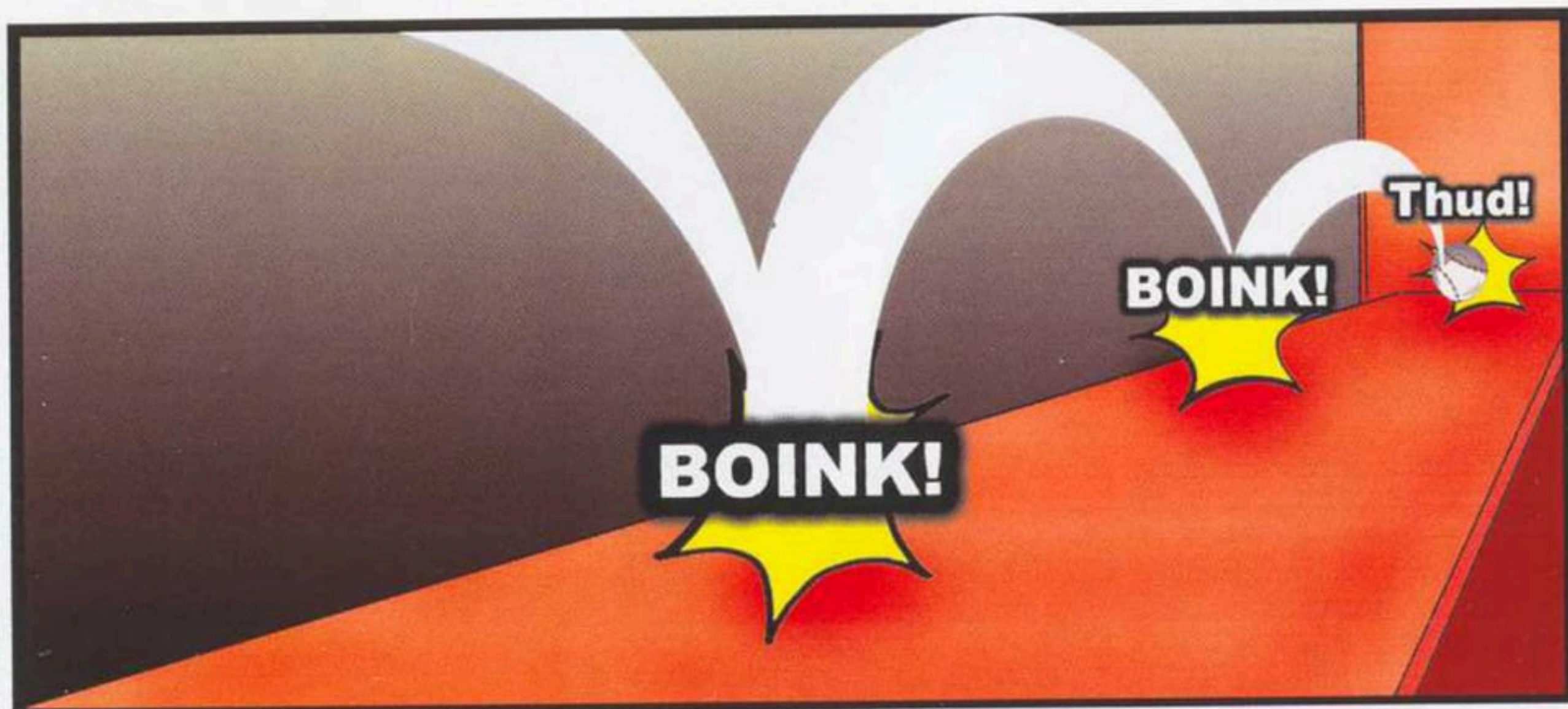
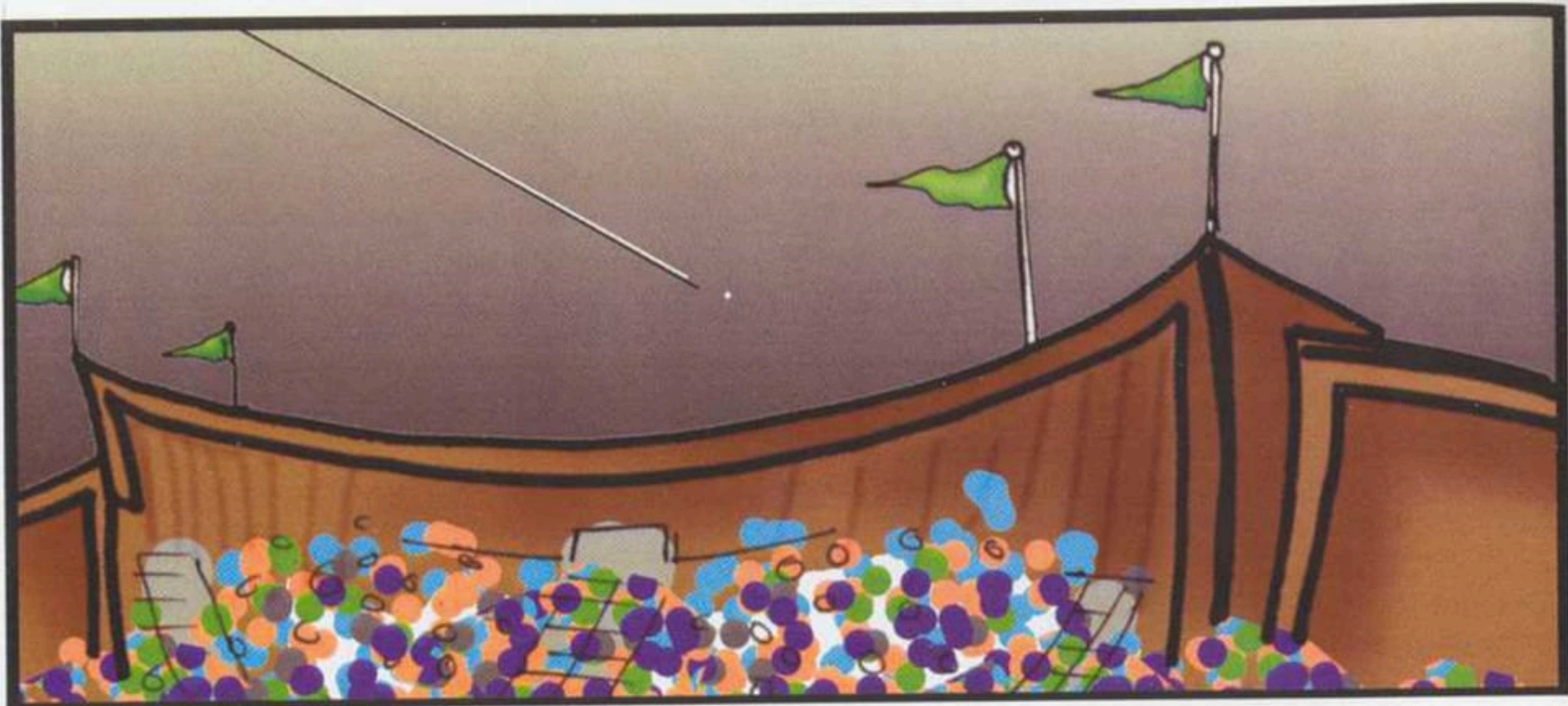



**BALL
BOY!**

Me?

Oh yeah, Me!

**The game can't continue
unless I go grab our
last ball back.**

Everything depends on me!



Hmm. Shoeless Joe...

The Babe...

**One day
I will be
known
as...**



CLIMBER 5!

GAME PROGRAM™ CARTRIDGE INSTRUCTION MANUAL

ATARI® and 2600™ are trademarks or registered trademarks of Atari, Inc.

CLIMBER 5 © 2004 by Dennis Debro. No guarantees, written or implied are made on this product. Neither Dennis Debro, AtariAge nor AtariCart are responsible for any damages caused by the use of this product.

Game developed by: Dennis Debro

Cartridge and Manual Published by: AtariAge Web site: www.AtariAge.com

Label Artwork, Layout, Concept and Manual Artwork by: Jason Dvorak

Manual Layout by: Dale Crum / AtariCart Email: Dale@AtariCart.com

NOTE: Always turn the console POWER switch OFF when inserting or removing an ATARI® Game Program™ cartridge. This will protect the electronic components and prolong the life of your ATARI® Video Computer System™ game.

