



LANCELOT™



GET INTO SOME HEAVY METAL

Datascop®

LANCELOT

This adventure recreates the tales of King Arthur and the Knights of the Round Table, as related in Sir Thomas Malory's *Le Morte D'Arthur*.

The game starts with a different scene of the meeting between Arthur and Lancelot than the one in Malory's tale. It also gives Lancelot a few adventures that Malory ascribed to other heroes of the Round Table. Other than this, the adventure is reasonably faithful to *Le Morte D'Arthur*.

Parts 1, **Camelot** and) recreates Lancelot's arrival at Camelot and his rise to become the best knight in the world.

Part 2, **Logris**, involves the completion of the company of Knights of the Round Table.

Part 3 is **The Quest for the Holy Grail**, the highest achievement in chivalry, in which the best knights come near to God. However, it leads to the demise of the company of the Round Table.

Concept and Game Design: Pete Austin

Game Program: Mike Austin

Story and Final Game Text: Christina Erskine

Systems: Mike and Nick Austin, John Jones-Steele, Mike Bryant

Computer Translations: Nick Austin and Mike Bryant

Pictures: Joan Lamb, Neil Scrimgeour, Dicken Peeke

Documentation Design: Kathi B. Somers

Lancelot game © 1988 Mandarin Software.

Datasoft is a registered trademark of IntelliCreations, Inc., a Software Toolworks company.
Apple is a registered trademark of & Macintosh is a trademark licensed to Apple Computer, Inc.

ST is a trademark and Atari is a registered trademark of Atari Computer, Inc.

Workbench is a trademark and Amiga is a registered trademark of Commodore-Amiga, Inc.

Commodore 64/128 is a trademark of Commodore Business Machines, Inc.

IBM is a registered trademark of International Business Machines, Inc.

©1988 IntelliCreations, Inc. All rights reserved. Printed in USA.

TABLE OF CONTENTS

GETTING STARTED	1
Amiga	1
Atari ST	1
Commodore	1
Macintosh	1
MS-DOS	2
SAVING GAMES.....	2
SaveTo Disk.....	2
RAM Save.....	2
GAME COMMANDS.....	2
Movement.....	3
Action.....	3
Commands To Others.....	3
System.....	3
HINTS.....	3
Camelot.....	3
Logris.....	3
The Quest For The Holy Grail.....	4
General Hints.....	4
KING ARTHUR & THE KNIGHTS OF THE ROUND TABLE	5
The Birth of a King.....	5
The Sword in the Stone.....	6
Excalibur.....	7
Guenever.....	8
Merlin and Nimue.....	9
Sir Lancelot du Lac.....	9
The Coming of the Holy Grail.....	11
The Quest for the Holy Grail.....	13
The Death of Arthur.....	17
Epilogue.....	19

GETTING STARTED

Lancelot is designed for Amiga 500/1000/2000; Atari ST (520 or 1040); Commodore 64/128; Macintosh (256K minimum memory) and Macintosh Plus; and MS-DOS machines (IBM PC and compatibles, 256K minimum memory).

Before loading the game, format a blank disk to use as a Save-Game disk (consult your computer users' manual for disk-formatting instructions).

- Amiga**
- 500:** Insert game disk into drive and turn on computer. The game loads.
- 1000/2000:** Insert Kickstart™ disk and turn on computer. When you're prompted for Workbench™, insert game disk. The game loads.
- Drag the picture up (to uncover the text) or down (to see the graphics) using the left Mouse button. You can do this at any time during the game.
- Atari ST**
- Insert game disk into drive Ø; turn on computer. The game loads.
- You can change the size of the on-screen text. Experiment by typing a line or two of text; *don't* press RETURN. Now, press F1 and F2 until you get the size of text you like.
- Drag the picture up (to uncover the text) or down (to see the graphics) using the left Mouse button. You can do this at any time during the game.
- There is a self-running demonstration game. To see it, press Alternate R when you see the "What now?" prompt. To escape the demo, reboot the game.
- Commodore**
- Turn on TV or monitor, disk drive, and computer (with C-128, hold down Commodore key while turning on the computer). Insert game disk into drive and close the door. Type **LOAD "*" ,8,1** and press RETURN. The game loads.
- Most of the graphics are on Side 2 of the game disk. If you want to play a text-only game, just start playing. If you want pictures, turn the disk over after the game has loaded and is waiting for your first command.
- Drag the picture up (to uncover the text) or down (to see the graphics) using the ↑ and ↓ cursor keys. You can do this at any time during the game.
- Macintosh/
Mac Plus**
- Insert your Mac operating system into the drive and turn on the computer. Insert the game disk; double click on the LANCELOT icon.
- Drag the picture up (to uncover the text) or down (to see the graphics). You can do this at any time during the game.

MS-DOS Machines

Insert DOS 2.1 (or later) into drive A; turn on computer. When you see the **A>** prompt, remove DOS and replace it with the game disk. Type **MENU** and press ↵. Select one of the 23 screen display formats from the menu and press ↵.

Note: To use the EGA mode, you must have a 128k EGA board. Not all these formats will work on all computers. If a format you've selected doesn't allow the game to run on your machine, reboot and make another selection.

To see a self-running demonstration game, press ALT R after selecting the screen display format and before pressing ↵. To escape the demo, reboot the game.

SAVING GAMES

These instructions for saving and loading games apply to all computers.

SaveTo Disk Use a separate save-game disk to save your games. Do not save games on your game disk. Anytime during gameplay, type **SAVE** and press RETURN. Follow the prompts.

To reload a saved game, type **RESTORE** (press RETURN), then **YES** (press RETURN), and follow the prompts.

RAM Save To save your game in the computer's memory while playing, type **RAM SAVE**. To reload a RAM-saved game, type **RAM RESTORE** and press RETURN.

Remember that saving in memory is quick and convenient -- it's an ideal way of saving your position before trying something risky.

Caution: A RAM-saved position will be lost if your computer is turned off, so save to disk occasionally.

GAME COMMANDS

The prompt (**more**) or (**shift**) (depending on your computer) lets you know when there's more text to display than will fit on the screen. Read what's visible, then press any key to continue.

When you see **WHAT NOW?** or **>**, you can type commands. After typing, press RETURN.

You can abbreviate commands (NORTH to N, SOUTHEAST to SE, INVENTORY to INV, etc.) and even type several commands on one line (EAST, TAKE ALL, WEST, etc.).

There are four kinds of commands in Lancelot: Movement, Action, Spell, and System.

Movement Type the name of the direction you want to go: NORTH, NORTHEAST, EAST (and the other compass directions), IN, OUT, UP, DOWN, ACROSS, etc.

Note: The game doesn't know the words GO and RUN.

Action Type the name of the action you want to accomplish: LOOK, TAKE THE HARP, DROP IT, EXAMINE THE CROSS, WEAR THE HAT, DRINK THE WINE, etc.

Commands to Others Type the name of the person, then the action: SIR GAWAIN, FOLLOW ME, etc.

System Type these commands to get information: INVENTORY (tells you the names of all items you're carrying); EXITS (tells you where all possible exits are from your current location); and SCORE (tells you how many points you've earned out of the number of possible points).

Type these commands to control how the game reacts to you: WORDS (turns off the graphics and gives you a text-only game); PICTURES (turns the graphics back on); BRIEF (gives short descriptions of locations); VERBOSE (gives complete details about locations); EXITS ON (gives the locations of all possible exits automatically); and EXITS OFF (gives the locations of exits only if you ask for them).

Type these commands to save and load games: SAVE (to disk), RESTORE (from disk), RAM SAVE; RAM RESTORE.

Type UNDO to go back a step to your previous action. Type this command over and over to go back several steps.

Type QUIT to end the game in progress and start over again.

HINTS

Below are hints for all three games, plus hints for the games in general. If you're really stuck, use the clue booklet included with this game.

- Camelot**
- Lancelot must go to Camelot to be knighted by Arthur.
 - He must do valorous deeds in Logris to become the best knight in the world.
 - When he returns to Camelot after achieving fame, he must look to Guinever.
- Logris**
- Despite the Damosel Maledisant's manner, her quest is genuine.
 - Lancelot must free all the captive knights; then he can command them.
 - Lancelot must ensure that Galahad comes to Camelot.

The Quest For The Holy Grail

- Virtue is vital; avoid sinning.
- Galahad is the holiest knight.

General Hints

- To make gameplay simpler, the objects that matter in a location are listed in a descriptive sentence, like, "You can see a shopkeeper and a bunch of herbs." The rest of the surroundings are probably scenery, but make sure by trying actions like, GET TREE, LOOK AT FLOWERS, etc.
- Examine all the objects that you see, and take everything you can. Most objects are useful in some fashion.
- You can solve some puzzles only with cooperation from other people, so get used to giving orders. To cancel orders you've given in error, type STOP after the name of the person you gave the order to (SIR GAWAIN, STOP).
- If you make a mistake and get "killed" or lose a vital object, use the UNDO command; it takes you back in time – hopefully to before the fatal mistake. You can use UNDO many times in succession to step backwards a long way through the game.
- Even weird or dangerous actions sometimes provide clues. Be sure to RAM-Save the game before trying a potentially fatal move.
- You can word a command in many ways. For example, if there were an axe and a ball on the ground, you could take the axe by typing any of the following:
 - > GET THE AXE
 - > TAKE AXE
 - > GET ALL BUT THE BALL
 - > LOOK AT THE AXE AND TAKE IT
- For more game background, read the stories that follow.

King Arthur & The Knights Of The Round Table

The following stories are a condensed version of the Arthurian legend, based on Sir Thomas Malory's *Le Morte D'Arthur*.

THE BIRTH OF A KING

In the days when Uther Pendragon was King of all England, the mighty Duke of Tintagel stood against him and, for a long time, warred against the King.

After many battles, Uther sent for the Duke that they might talk of peace. But he also charged him to bring his wife, Igraine, for Uther had heard she was most fair. And when the Duke and his wife were with Uther, the King declared his love to her. Igraine was much distressed and warned the her husband that they should flee, for the King surely intended her dishonor.

After they secretly departed, Uther was wrathful, both for pure anger and great love of fair Igraine. The Duke heard warning of this and made provision for a long siege. He set Igraine in Tintagel Castle, which was strongly fortified, while he set out for Castle Terrabil.

Ere long, Uther's pavilions and knights surrounded Terrabil and a bitter battle began. But Uther was sick with his love, and remained listless in his tent. His knights were greatly worried. In hope of a cure for the King, one of his men sought Merlin, a wizard renowned for his knowledge of ancient crafts and remedies. And Merlin said that he would help Uther, if Uther would be sworn to reward Merlin in his turn. The noble knight assented that Merlin should have whatever he desired if he could make Uther whole again.

Merlin rode to Uther's pavilion, where he told the King that Uther might spend the night with Igraine, for by Merlin's magic, he would appear to her in the likeness of her husband. In return, Uther must deliver any child born of their union for the magician to raise.

Uther could not hold his patience, and rode out with his party for Tintagel at once. The Duke saw Uther's knights riding hard, as if in retreat, and he left his Terrabil fortress to pursue in all haste. On the field, he met with Uther's remaining men, and was slain ere the King came to the castle of Tintagel. And so, as Uther lay with Igraine, she was already a widow.

Igraine thought her lover that night was her husband; but when she heard tell of the Duke's death she marvelled who that knight who lay with her might be. Even when she assented unto marriage with Uther, to unite their two houses, he did not tell her. And when the child was born, Merlin came, as he had told Uther he would, to take the baby away, reassuring the father he would be well-nourished.

But Uther was unable to spend a long and happy life with Igraine. Within two years he had fallen sick of a great malady and died, to Igraine's great sorrow, for she had learned to love him.

The rule of the Kingdom fell into jeopardy, for there was no known heir. Many lords made claim to the throne, and fought bitterly for the right to reign, but none could take the Kingdom by just cause.

THE SWORD IN THE STONE

After years of great feuding, Merlin went to the Archbishop of Canterbury and counseled him that he would find the right-born King. All the lords of the realm and all the gentlemen of arms were summoned to London for a New Year's Day tournament, where the new ruler would be revealed.

Sir Ector, his son Kay, and his adopted son Arthur were among those who rode to London for the jousting, Kay making great excitement, for he was to be made a knight at the tournament.

As they rode to the jousts, Kay discovered with dismay that he had lost his sword, for he had left it at their lodging. He prayed young Arthur to run back to collect it.

Arthur found the inn empty and locked; everyone had already left for the tournament. Trudging dolefully back to his father and brother, he went through a churchyard, where near the high altar, he espied, to his joy, a sword. It was stuck through an anvil, set upon a wide marble stone, and glittered in the winter sunlight.

"I will take that sword," Arthur decided. "My brother Sir Kay shall not be without a sword today of all days." He grasped it firmly and found that it came easily out of the anvil. Hurrying after his party, he never noticed the words that were written in gold about the sword.

But when Arthur delivered the sword to Kay, his brother turned quite pale. For Kay too had seen the sword in the stone in the churchyard, but he had also seen what Arthur had not, the lettering around it, which read:

WHOSO PULLETH OUT THIS SWORD OF THIS STONE AND ANVIL, IS
RIGHTWISE KING BORN OF ALL ENGLAND.

A small smile appeared on Kay's face as he took the sword from Arthur, and so he rode to find Sir Ector. "Look, father," he cried. "I have the sword from the stone. I must now be King of all England."

Sir Ector was no fool. He took Kay and Arthur back to the churchyard, and he made Kay swear upon The Book how he had come by the sword. Kay faltered. "My brother Arthur brought it to me", he said. Ector turned to his adopted son, and Arthur explained how he had taken it. Then Ector replaced the sword in the anvil and told Arthur to pull it out again.

"There is no great skill to it," said Arthur airily, and lifted it smoothly and cleanly out of the anvil.

Then Ector and Kay both tried pulling the sword from the stone for themselves, with all their might, but it would not move. When the two elder men learned full well that the sword would give only for Arthur, they both knelt down to the earth before him.

Arthur was greatly dismayed. "My own father and brother!" he exclaimed. "Why do ye kneel before me?"

"Nay, Arthur, I am not your father, nor of your blood," said Sir Ector gently, and for the first time he told the boy how Merlin had delivered Arthur to Sir Ector as a newborn baby, and charged him to nourish Arthur as his own.

At Pentecost, young Arthur was crowned at Carleon and took on the heavy duties of King of all England.

EXCALIBUR

The early years of Arthur's reign were not easy. Many lords and Kings had no joy of him because of his youth and lowly upbringing and he spent much time in bloody battles, defending his right to the throne. Merlin was ever nearby to help him when he was on the brink of defeat, and after long years, Arthur finally vanquished most of the enemy lords.

As a young man, Arthur fathered two children, Borre and Mordred. Mordred's mother was Margawse, wife of King Lot of Orkney and the daughter of Igraine and the Duke of Tintagel. Though none could know but Merlin, she was Arthur's half-sister, and Merlin blamed the King.

"God will not forgive your foul deed," the magician warned. "You have lain with your sister and on her ye have gotten a child, born on May day, that shall destroy you and all the knights of your realm."

Sore afraid at Merlin's words, Arthur sent for all the children born on May day, and he set them adrift in a ship. The ship was wrecked and the most part of the children perished, but Mordred was washed up alive on a beach, and raised by a good man.

Arthur's battles were long and bloody and oft there was danger that he might be slain, so Merlin thought that Arthur should have his own special sword. He took Arthur on a journey to a wide and still lake, and, in the middle of the waters, an arm, clothed in rich samite silk, rose from the water. The hand was clasping a fair sword.

"This is the sword that shall be yours," Merlin told Arthur. "The Lady of the Lake will come to you, and ye must speak fair to her to get the sword. And indeed the Lady told Arthur to row out in a barge to the centre of the lake to take the sword and its scabbard.

When he returned to the shore, he looked on his new sword and liked it well. Merlin asked him, "Which do you like better - the sword or the scabbard?"

Arthur considered. "The sword," he replied.

Merlin looked at him. "Ye are still so unwise," he said with annoyance. "The scabbard is worth ten of the sword. While ye have the scabbard with ye, ye will never lose blood however sorely wounded ye may be."

GUENEVER

When Arthur first saw Guenever, daughter of King Leodegrance of Camelot, he knew straightway that he wished to marry her. Arthur thought her the most valiant and fairest lady living.

But, as ever in these early years of his reign, he asked for the counsel of Merlin, for he was still for the most part ruled much by the magician's words.

"In beauty and fairness she is above all women," Merlin assented. "But if your heart was not set, I could find you a damosel of great beauty and goodness, who would certainly please you. But when a man's heart is set, and there is nought that can make him return."

Merlin further advised the King against taking Guenever as his wife, "I warn you, she will be loved by Lancelot du Lac, and she will love him back." But Arthur's mind was set fast on his choice, and so Merlin went forth to King Leodegrance to tell him that King Arthur wanted his daughter for his wife.

Leodegrance, to be sure, was overjoyed. "That is the best tidings that ever I heard," he cried. "And I shall send Arthur a gift, which might please him more than lands, for he has lands enough. I shall give him the Table Round, which was given to me by Uther Pendragon. The Table will seat a hundred and fifty knights, and I will myself send a hundred good knights."

Leodegrance was right. The gift of a hundred knights and the Table Round pleased Arthur far greater than land, and he sent out Merlin to find fifty

accomplished knights to complete the number, while he made preparations for the royalest wedding he could devise. But Merlin could only find forty eight knights of enough prowess to grace the Table Round, and so there were two empty seats.

Then Merlin, by his magic craft, made each of the names of the knights appear in gold lettering in their places at the table, and in just two places was there no name.

As the knights came to Camelot, where the King was wedded unto Guenever, Arthur set out their duties as Knights of the Table Round. He charged them never to commit treason or murder, never to be cruel, never to enter into battle for a wrongful reason whatsoever the reward, but ever to grant mercy when it was asked for, and ever to help ladies, whether gentlewomen or damsels, whenever succor was needed. And every Knight was sworn to this oath and every year at Pentecost they affirmed it again.

MERLIN AND NIMUE

Merlin fell in love with one of the ladies of the lake, called Nimue (sometimes known as Viviane). He became besotted upon her and could not bear to be away from her, and she kept in his company until he had taught her all manner of things she desired to know of his magic crafts.

Merlin also knew that despite all his magic, he would not live long in the earthly world, so he told Arthur prophecies that would befall the young King. He warned him to keep always his sword and scabbard with him, and he told him of the end of his reign and of the last days of the Table Round.

Soon afterward Nimue departed from the court, and Merlin went with her. He followed her wherever she went, and within a while Nimue began to be weary of him.

Then one day Merlin showed her a rock, inside which were marvels wrought by enchantment. Nimue tricked Merlin by subtlety and made him go underneath the rock, to tell her of the marvels, and then, by use of the crafts which he had taught her, she enclosed the rock.

Merlin was not harmed, and spoke happily enough to passing knights, but, no matter what charms Merlin practised to assay to open up the rock, he remained trapped.

SIR LANCELOT DU LAC

As King Arthur's reign drew on, and the deeds of the Knights of the Table Round became ever more renowned throughout the land, so many knights came to the tournaments and jousts.

Some knights who came off improved their prowess so that they surpassed most of their fellows, but none more so than Lancelot du Lac. Never in any of his fights was he beaten, unless it were by trickery, and he was the knight who was admired most of all by the people after Arthur. And because of his excellence, Queen Guenever favoured him above all other knights, and he favoured her, and many of his great knightly deeds were done for love of Guenever.

Sir Lancelot was riding in Corbin, when he saw the fairest tower he had ever seen. Inside was the lady, Elaine, enchanted to remain in scalding water until the best knight in the world should take her hand. Lancelot rescued her; she thanked him, and he thought she was the fairest lady in the world, apart from Guenever.

Lancelot slew a fiendish dragon nearby, then they rode to Carbonek, castle of Elaine's father, King Pelles. At the celebratory feast, a damsel came into the hall, carrying a golden vessel, which shone richly with a pure and dazzling light. King Pelles knelt in front of the vessel, and prayed devoutly before it, and all the company did the same after him. Lancelot marveled much at this and asked wonderingly what this apparition meant.

"This vessel is the richest thing that any living man could have," replied Pelles. It is the Holy Grail, blessed by Our Lord at the Last Supper." And he left Lancelot to ponder on this marvel. Lancelot found that, after the appearance of the Grail, all the wounds and bruises he had suffered in his joust had healed and that his flesh was smooth and new, and he determined to see the Grail once more before he died.

King Pelles knew it was ordained that Elaine should conceive a child by Lancelot; that the child should be named Galahad; that he would become the best of all knights, surpassing even his father; and that he would be worthy of the Holy Grail. Yet how could it be done, fair though Elaine was, when every man knew that Lancelot kept himself only for love of the Queen Guenever?

Then Dame Brisen, one of the greatest enchantresses that lived at the time, came unto Pelles, and told him that she could work this thing by using her crafts.

Lancelot was given wine, which had Brisen infused with potion to make him blinded with lust, and when he was taken unto Elaine's chamber, he thought that she was Guenever, and lay with her until morning.

Elaine knew well that the child she carried from that night was born to be the noblest knight in the world, and when he was born, she christened him Galahad, and kept him well and nourished him. But Lancelot was shamed by the trickery, and left the castle that same morning to continue his travels.

Some months after, Arthur decreed that a feast be held.

Elaine deemed it right that she should attend the feast and bring the baby Galahad with her. She came with her servant Dame Brisen, and a retinue of twenty knights, and was so richly attired that all of Camelot agreed she was the fairest lady ever seen in that court. All, that is, save Lancelot, for fear of Guenever's fury.

Elaine was heavy of heart that Lancelot would not speak kindly to her, nor look at her, and went unto Brisen for advice. The enchantress assented to work her special powers so that Elaine might lie again with Lancelot that night.

When the court had retired, Guenever commanded Elaine to sleep in a chamber near her own, and she bad Lancelot to come unto her in the night. "Or else I am sure," chided Guenever, "ye will go to your lady Elaine's bed, for have you not got a son by her?"

But Brisen's enchantments were stronger than Lancelot's promises; she came to Lancelot in the likeness of one of Guenever's maidens, and led him to Elaine's chamber instead of Guenever's. Lancelot thought that it was Guenever he held in his arms, for so Brisen had devised it.

Then Guenever sent her servant to summon Lancelot to her, but the servant came to the Queen and said that she had found Lancelot's bed cold and empty. The Queen went nigh out of her wits with wondering where he was. She was not long in doubt, for Lancelot had the habit of talking in his sleep, and through the walls, she could hear his voice in Elaine's room.

Then was Guenever nigh mad with anger and with pain. She knew not what to do, but then she coughed so loudly that Lancelot awoke, and he heard her cough. Then he knew too that he lay not with his queen as he had thought and ran out of Elaine's chamber, only to meet a white-faced Guenever in the passageway.

"Thou false traitor knight!" she cried. "Never more wilt thou abide in my court; never will I let thee come into my sight again!" Lancelot could not bear the anger of her words and, filled with shame and the loss of his love, he leapt from the castle window.

Lancelot ran mad in the forests, sometimes tended by hermits and village folk, more often living off berries and plants. Only after many years did he return to King Arthur's court.

THE COMING OF THE HOLY GRAIL

Each year, the Knights of the Table Round came to Camelot for the high feast of Pentecost, to relate their deeds and the marvels they had seen. But still the Table was not complete, for the last place, the Seige Perilous, was not filled.

Then one year the knights had found, according to the custom, that their names were written about the Table Round in gold lettering, but this time there were new words written above the empty Siege Perilous.

FOUR HUNDRED WINTERS AND FOUR AND FIFTY ACCOMPLISHED
AFTER THE PASSION OF OUR LORD JESUS CHRIST OUGHT THIS SIEGE
TO BE FULFILLED.

"It seemeth me," said Sir Lancelot who had accounted the time between the birth of Christ unto that day itself, "This siege ought to be fulfilled this very day, for this is the feast of Pentecost after the four hundred and four and fifty year."

And the other knights agreed, and they ordained to cover the Siege Perilous with a silken cloth, so that the letters could not be seen until the rightful knight came unto the Table.

As they set themselves in their own places at the table the next evening to be served their feast, an old man accompanied by a very young, fresh-faced knight, unarmed, save for an empty scabbard at his waist, came unto the hall at Camelot.

And as the other knights set all eyes upon the two, the elderly one led the young boy right up to the Table Round, and he led him to the Siege Perilous, where beside sat Sir Lancelot.

The old man lifted up the silken cloth, which showed that the words inscribed in gold had changed again. Now it read:

THIS IS THE SIEGE OF GALAHAD THE HIGH PRINCE.

The old knight set his young charge surely in that seat, and departed, so that the boy was in the centre of the others' looks. Many marvelled that one so young did dare sit in that siege, but Lancelot knew him as his own son, and his heart swelled up with pride.

The next day, King Arthur took Galahad to a lake near Camelot, where the court had found a sword set into a stone in a lake. This sword was inscribed with lettering, which read that only the best knight in the world could pull the sword clear.

Now, many thought that this knight must surely be Sir Lancelot, but Lancelot had remembered the sins of his love for the Queen, and had said he was unworthy to try the sword. Sir Gawain and Sir Percival were both knights of great renown, but when they tried to lift the sword, it would not move.

Now Arthur was sure that Galahad was the rightful owner of the sword, and so it was, for Galahad lifted it cleanly and easily, and it fitted perfectly into his empty scabbard.

Then Arthur organised a great jousting tournament, that Galahad might test his skill against the other knights. And Galahad acquitted himself superbly, and many good knights of the Table Round were unhorsed by the young man, save two whom he did not fight, Lancelot and Sir Percival.

That evening the knights were again come unto the hall in Camelot for their supper, every man in his place at the Table Round, and this time there were no empty seats.

Scarcely had they sat down, when there was a great cracing and a crying of thunder that shook the very walls of Camelot, and in the midst of this clamour a great burst of light flooded into the hall, like a sunbeam that was seven times clearer than daylight.

Then all the knights felt themselves filled with the grace of the Holy Ghost. They beheld one another to be fairer than ever they were before, and they were struck dumb by the brilliance of the light.

Then came into the hall a golden centre to this light, and it was the Holy Grail, covered in a cloth of white samite, so that none could see the vessel underneath. And with the Grail came all manner of meat and drink that the knights loved best.

As the Holy Grail crossed over the length of the hall it vanished as suddenly as it had come, and in the sudden emptiness of the hall after its passing, the knights all burst into voice at once.

Sir Gawain, ever impetuous, leapt to his feet and spoke unto the company. "One thing has beguiled us this evening," he cried. "We could not see the Holy Grail because it was so preciously covered. And I will vow here and now, that tomorrow without delay, I will go out in quest of the Holy Grail. I will labour for a year and a day, or longer if needs be, and I shall not rest until I have seen the Grail more openly than it has been seen here."

The other knights were greatly inspired by this and once Gawain had sat down, each of them rose and made vows such as he had done. And as they were rejoicing and making great plans for their quest, only Arthur was silent.

For Arthur remembered the prophecies and teaching of the soothsayer Merlin, and he knew that many of his knights would never return, and the Table Round would never be restored.

THE QUEST FOR THE HOLY GRAIL

The quest for the Holy Grail continued for many years, and all the knights who set out to seek the Holy vessel had many marvelous adventures, but none more than Sir Lancelot who was to see the Grail at Castle Carbonek, or Galahad whose destiny was to fulfil the quest.

Lancelot rode hard for several days, until he came unto an old chapel, where he thought to find himself rest.

He tried to enter therein, but could only reach the altar, richly arrayed in silk and with six great candles set into a fair silver candlestick. He could find no entry to the chapel itself and at last, tired and dismayed, laid himself to sleep on his shield at a stony cross outside.

He was half wakened some time after when two fair white palfreys rode up to the cross. The palfreys bore a litter which carried a sick knight, that moaned in pain for the Holy Grail to come to heal him.

Lancelot stirred, still half asleep, for it seemed to him that he could not rise into wakefulness, and he espied the candlestick from the altar carry itself, as if floating, unto the cross. It was followed by a silver table, and the shining holy vessel of the Holy Grail, although Lancelot could see none that was bearing it aloft. He heard the sick knight sit up and welcome the Holy Grail, and he saw him kneel down to the ground to touch the vessel and kiss it. Then the knight rose up again whole and healed. The Holy Grail remained at the cross for a long while before it glided back into the chapel, and yet still had Lancelot no power to follow it.

After some hours Lancelot woke fully. He recalled how the sick knight had been healed, but it was as though it were all a dream. And even as he thought this, a voice came to him, and told him to withdraw from the holy place in which he had been sleeping, for he was unworthy.

Lancelot was sore unhappy and wept at these words, and the more unhappy still when he discovered that his horse and helm and sword had been taken away by the healed knight, yet he knew well the message.

"My sin and wickedness have brought me unto great dishonor. When I sought worldly adventures and worldly desires, I achieved them. Now I have taken up a holy adventure and my old sin has come back to shame me, so that I have no power when holy blood appears before me."

With much sorrow, Lancelot departed from the cross on foot and went unto a hermitage where the hermit would hear his confession. The hermit counseled Lancelot that his shame in God's eyes had to do with his sinful love for Guenever, and that he should forswear his lust for her. And Lancelot fully repented of his earthly sins, and with the hermit's blessing set out to start his quest afresh.

After many months, Lancelot came unto the water of Mortaise, where he laid down to rest. A vision came to him in his sleep and told him to enter the first ship that he could find. Lancelot arose and went to the strand, where he found a ship without either sail or oar and he entered and a great feeling of peace and joy overwhelmed him, and he remained with the ship for over a month.

Then one day, somewhat weary of the small ship, he was sitting on the shore when he heard a thundering of hooves, and a most seemly looking knight on a fair horse galloped up to the shore. He dismounted and, taking his saddle and bridle with him, went straight into the ship.

Lancelot followed, curious about this self-assured young man, and made himself known to the young man, whereupon the knight revealed that he was Sir Galahad, Lancelot's own son. There was much rejoicing between them as the two embraced, and told each other of their adventures.

Galahad had ridden from Camelot into strange lands. Many adventures befell him and always he was successful in his endeavors and gained much in knightly experience. He had defeated many knights in fair combat, he had given support to the defenders in a great siege at a castle, and with their comrades Sir Bors and Sir Percival, he had been set adrift to sea in a boat which had beached them in the marshes of Scotland, there to do battle with many knights who had challenged them.

Lancelot made great joy to hear his tales. His own quest had been tortuous, with little success, and he took much pride in his son. For a full six months, Lancelot and Galahad voyaged together in that boat, encountering many perilous adventures.

But never did they come near the Holy Grail, that was the true nature of their quest and so Galahad then left the ship to seek the vessel as he was ordained.

This made Sir Lancelot sad, for he was alone and downhearted, but he prayed daily to God that he might still see some tidings of the Holy Grail. The ship carried him over the sea, he knew not whereto, but trusted it to steer him safely.

After a month at sea, the ship beached at midnight beside a fine castle. A postern opened out towards the sea and a voice bade Lancelot to enter in. Lancelot armed himself and went to the gate, for here, so he thought, might at last be his adventure.

As he neared the castle, Lancelot saw two lions on guard. He drew his sword, but it was smitten from his hand and a voice chided his evil faith, that he put more trust in weapons than in his Maker.

He entered the castle without further challenge, but inside he could find no door or gate which would open. But behind one door he could hear sweet and reverent singing, and he knew full well that the Holy Grail was in that room. Lancelot fell to his knees and prayed to God to show him at least some part of the Grail.

He looked up from his prayers and was filled with awe to see the chamber door swing slowly open. From inside shone out a great light, that was the clearest, purest light Lancelot had ever seen.

Lancelot looked up and into the chamber, and there was the silver table, and the Holy Grail covered in red samite and all the ornaments of an altar, and a priest who seemed to celebrate mass. Lancelot could not bear to stay outside, and taking a deep breath, he strode into the room where the Grail was.

As Lancelot reached out to touch the Grail, a scorching wind threw him down. His body would not move, and then he felt hands all about him, that carried him out of the room and left him in the passageway.

The next morning the people of the castle found Lancelot's body outside the chamber door. He was taken to a bedchamber, where he lay without stirring.

Lancelot awoke on the twenty fifth day and learned that he had achieved as much of the Holy Grail as he would ever see, and Lancelot understood and thanked God for that which he had been allowed.

Elsewhere, Galahad, since departing from the ship, had many further adventures before he met again with Sir Percival and Sir Bors. The three of them then rode together until they came to the Castle Carbonek. When they entered within, King Pelles was full glad to see them, for he knew that now the quest for the Grail would be achieved.

King Pelles, his son Eliazar, and the three Grail knights sat down to dinner, but before they could eat, a voice came to them. "There are two among you that are not in the quest for the Holy Grail, and therefore you both should depart."

King Pelles stood up. The moment had come, and with a single look at Galahad he and his son slipped away. Scarce had they gone, when a man and four angels appeared before the knights. The angels set the man down before a table of silver and on the table the Holy Grail appeared.

The man, who was dressed as a bishop, set about the ritual of the celebrating of mass. He kissed Galahad and bade Galahad kiss his fellow knights, which he did and then the bishop vanished away.

The three knights sat at the table in full dread of what might next happen. They looked up and saw a man come out of the holy vessel, a man with open wounds bleeding freely, as did those of Jesus Christ, and he offered the holy vessel to Galahad.

Galahad knelt and received his Saviour, and Our Lord then told Galahad that he must depart with Bors and Percival the next morning to the sea, where he would find a ship waiting for him.

On the morrow, the three knights set off, and after three days came to a rivage where they found a ship waiting for them. On board the ship they found a table of silver and the Holy Grail covered in a cloth of red samite. The three knelt down and prayed with much reverence.

The ship took them across the water to the city of Sarras. They disembarked and, taking the table of silver, went into the city where they remained for a full twelve months.

On that day at the year's end, the man in the likeness of a bishop came to Galahad and Bors and Percival, and he had the Holy Grail with him. They celebrated mass, and the man revealed himself to the knights as Joseph, son of Joseph of Arimathea, and now Galahad knew that his time on earth was near an end.

Galahad kneeled before the table which held the Holy vessel and made his prayers, and as he did so, his soul departed quickly and quietly to Jesus Christ. The watching Percival and Bors perceived a great multitude of angels take it up to heaven. They saw too that a great hand came down and took the Vessel and bore that up to heaven as well. And this was the last that any earthly man saw of the Holy Grail.

THE DEATH OF ARTHUR

When the Holy Grail had been achieved and that part of the knights that still lived had come back unto the Table Round, it seemed that the Kingdom would be as great as it had been before.

But Sir Lancelot soon forgot his repentance and his vows of the quest. Soon he began to resort unto Queen Guenever again, and truly the love that was between them was so great that they spent many hours together privily. Arthur was told, but he wished only for peace, and would not believe unless Sir Lancelot was taken with the deed. So Agravain and Mordred, who hated Lancelot, lay in wait with twelve knights and trapped him in the Queen's chamber.

Though he had none armour, shield, sword nor spear, Lancelot fought free and escaped, slaying all but Mordred, who fled to the King. Guenever was sentenced to the fire, but Lancelot returned to rescue her and they left Logres for Lancelot's lands in France.

For himself, Arthur desired only peace with Lancelot, for he had loved him well in earlier days. But Arthur listened to the counsel of Gawain, who was his nephew. And Gawain was mad for vengeance, for Lancelot had slain his bretheren in the rescue.

So Arthur took his army to France, leaving Sir Mordred to rule England in his absence, for Sir Mordred was his own natural son. And Arthur also put his wife Queen Guenever under Mordred's governance.

All the while Arthur was waging battle in France, Mordred made mischief at home. He forged letters the which he said had been sent from France, telling of Arthur's death in battle, and was himself crowned at Canterbury.

Next Mordred announced his plan to take Guenever as his wife. The Queen was passing sad, but she hid her heart and agreed to the wedding. Mordred trusted Guenever well and gave her leave to go to London, to buy all manner of things for their wedding, whereupon she went straight to the Tower of London and stocked it for a long siege.

When Arthur heard of all these deeds, he summoned his knights and turned for England to be avenged upon Mordred. The battle between them was bloody and vicious, but Arthur's courage and his men's prowess prevailed and, although many good knights died, Arthur's armies were victorious, though Sir Gawain was killed. Mordred retreated to Salisbury.

The final battle was assigned for Salisbury on the day after Trinity Sunday. The night before, Arthur could not sleep; his heart was heavy with the decline of his Kingdom and the enmity of Lancelot. At last he fell to sleeping fitfully, and as he slept, he dreamed, and it seemed that the ghost of Gawain appeared to him.

"I have come to warn you of your death," said the Gawain of Arthur's dream. "If ye fight with Mordred as ye both have assigned, doubt not that ye will be slain. But within the month, Sir Lancelot and all his noble knights will come to England to your rescue."

When Arthur woke, he called his two most trusted knights remaining, Sir Bedevere and Sir Lucan, and charged them to make a truce with Mordred. After some hours it was agreed, and the two leaders arranged to affirm the treaty betwixt their armies on Salisbury Field, and each should bring just fourteen knights.

Arthur and Mordred met, and were agreed. But it chanced that an adder slithered out of a heath bush, and it bit one of the knights on the foot. He drew his sword to kill the snake and the knights of the armies, that had been so wary, saw the point of the sword glinting in the sun and shouted, "Treachery!"

Suddenly all was bugles blowing and trumpeting, and the two hosts set upon each other in the most doleful battle of them all, until both armies were destroyed. Arthur slew Mordred and was himself wounded unto death.

The King turned to Bedevere, last of his knights, "I have not much time left," he said painfully. "Therefore, take my sword Excalibur and throw it into yonder lake." Bedevere took the jeweled sword and went down to the lakeside, but he hid it behind a tree. "I have done as you ask," he told Arthur.

"What saw thou at the lake?" asked Arthur. "Sire," replied Bedevere, "I saw nothing but waves and the wind on the water." "Then thou art lying," said Arthur heavily. "Go again, and quickly, for thy tarrying puts my life in jeopardy."

So Bedevere returned to the lake, and took up the sword and after a moment's hesitation, hurled it as far into the depths as he could. As he looked across the water, he saw a fair arm and a hand rise out of the lake and it caught the sword as it fell."

Arthur was satisfied. He charged Bedevere to take him down to the lakeside, where a barge drew alongside the water's edge. In the little barge were a number of fair ladies, all with black hoods, and when they saw King Arthur they wept and keened greatly. Bedevere placed the weakened King into the barge, where the ladies received him with great mourning.

Arthur struggled to speak. "Bedevere, I must go into the vale of Avalon to be healed of this wound." And Bedevere watched the barge as it sailed away.

EPILOGUE

When Queen Guenever heard that Arthur was slain, and of the bloodshed on Salisbury Field, she stole away to a nunnery at Almesbury, and spent the rest of her days in penance for her sins.

As Gawain had prophesied in Arthur's vision, Lancelot landed at Dover within a month, having heard of Mordred's treachery. He was too late to save Arthur, but was determined to see his lady Guenever again. For seven days he was on the road and on the eighth he came to a nunnery. As he entered the cloister, a nun dressed all in black and white saw him there and swooned.

They spoke together for a short time, and when Lancelot saw that Guenever had taken to a life of penance, he decided that this should be his destiny, too. He took to his horse, weeping for the loss of his love, and rode until he came to the hermitage at Glastonbury, where he took on a monk's habit.

Lancelot saw Guenever just once more, many years later. One night, a vision charged him to ride with all haste to Almesbury. This he did, but he was too late, Guenever was dead but a half hour since. Without his lady, Lancelot would eat but little meat, nor drink, until he sickened more and more and dwindled away. Within six weeks he too was dead.

Of King Arthur there is little more to be told. Some say he rests in Avalon. Others say he is not dead at all, but sleeping and will come again, with his Knights of the Table Round, when the need is greatest.

Datasoft®

19808 Nordhoff Place, Chatsworth, CA 91311/(818) 858-9000

CLUE BOOK FOR

LANCET

LANCELOT CLUES

Clue Book Designed By Kathi B. Somers

Maps Drawn By Thomas J. Clement

This book contains clues and maps for all three parts of the **LANCELOT** game.

As you play the game, note on your maps where you find particular items, people, or creatures. This way, if you neglect to save your game to disk or some other disaster befalls, you'll have an easier time of retracing your steps.

LANCELOT CLUES

Listed alphabetically below are most of the objects, creatures, people, and locations, in *Lancelot*. These clues are divided into sections corresponding with the three parts of the game: *Camelot/Logris* General Clues, Objects, Creatures & People; *The Grail Quest* General Clues, Objects, Creatures & People; and Answers for all three parts of the game.

To find out about an entry in the list, look up the bracketed numbers next to the entry. Keep looking up the numbered answers until you have all the information you need about an entry. These clues are designed so you get only a small bit of information at a time, without giving away too much of the game.

Example: *Armour: where (751); details (764)*. Look up entry 751, and you'll see that the Armour is *Worn by Lancelot*. Entry 764 tells you the Armour is *Always with Lancelot, except when he climbs the elm (703) or says farewell at the end (795)*. Look up 703 and...well, you take it from there!

A few "red herrings" have been mixed in with the real clues. You won't be referred to them if you use the clue sheet as instructed, but reading random entries can be misleading!

Camelot/Logris General Clues

- 01 Beginning the game (664).
- 02 Finding things (725).
- 03 Finishing *Camelot/Logris* (814).
- 04 Game background (850).
- 05 Going places (737).
- 06 Knights to rescue (683).
- 07 Orders to People (671).
- 08 Scoring (750).
- 09 Solution (900).

Camelot/Logris Objects

- 10 Anvil: where (624); details (650).
- 11 Apple Tree: where (570); details (707).
- 12 Armour: where (751); details (764).
- 13 Arrows: where (758); details (774).
- 15 Bars: where (123); details (620).
- 16 Bath: where (386); details (811).
- 17 Battering Ram: where (624); details (700).
- 18 Beacon: where (562); details (955).
- 19 Bed (Guenever's in Castle Meliagaunt):
where (334); details (851).
- 20 Bed (Guenever's Room): where (335);
details (582).
- 21 Bed (Lancelot's Room): where (342);
details (606).
- 22 Bed (Merlin's): where (362); details (651).
- 23 Bed (Meliagaunt's Guest Room): where (361);
details (582).
- 24 Bed in Perilous Bedroom: where (370);
details (701).
- 25 Bed (Straw): where (363); details (642).
- 26 Beetroot: where (346); details (665).

- 27 Blood Stain: where (712); details (740).
- 28 Boat: where (808); details (852).
- 29 Books: where (383); details (561).
- 30 Briers: where (625); details (652).
- 31 Bushes: where (367); details (881).
- 35 Cage: where (390); details (971).
- 36 Candle: where (281); details (800).
- 37 Cask: where (340); details (583).
- 38 Cart (Camelot): where (595); details (954).
- 39 Cart (Cornwall): where (601); details (889).
- 40 Cauldron: where (53); details (653).
- 41 Chest (Guest Suite): where (361); details (583).
- 42 Chest (Orkneys): where (605); details (717).
- 43 Cloth: where (302); details (622).
- 44 Coals: where (53); details (726).
- 45 Collection Bowl: where (292); details (606).
- 46 Crossbow: where (377); details (981).
- 47 Crystal: where (281); details (781).
- 50 Dead Wood: where (312); details (654).
- 51 Drawbridge: where (360); details (602).
- 52 Elm Tree: where (592); details (703).
- 53 Fire: where (275); details (583).
- 54 Flag: where (346); details (853).
- 55 Food: where (87); details (560).
- 56 Footstool: where (335); details (623).
- 57 Glass (Wine): where (626); details (708).
- 58 Gloves: where (41); details (780).
- 59 Grail: where (817); details (838).
- 60 Hammer: where (10); details (704).
- 61 Hand: where (100); details (659).
- 62 Harp: where (224); details (615).
- 63 Hat: where (41); details (859).
- 64 Hedge: where (346); details (882).

CAMELOT/LOGRIS CLUES

- 65 Holy Grail: where (817); details (838).
- 66 Horn: where (351); details (705).
- 70 Inscription: where (754); details (576).
- 71 Keyhole: where (387); details (606).
- 72 Lamp: where (291); details (746).
- 73 Lever: where (390); details (628).
- 74 Lift Cage: where (390); details (971).
- 75 Loose Planks: where (328); details (854).
- 76 Lunes: where (182); details (703).
- 80 Manor: where (563); details (974).
- 81 Mirror: where (716); details (752).
- 82 Oat Cakes: where (624); details (665).
- 83 Panel: where (370); details (887).
- 84 Pile (Sails): where (106); details (755).
- 85 Pillow: where (24); details (727).
- 86 Planks (Loose): where (328); details (854).
- 87 Plate: where (217); details (583).
- 88 Plough: where (797); details (957).
- 89 Poison: where (226); details (706).
- 90 Portcullis: where (388); details (972).
- 91 Pot of Stew: where (391); details (606).
- 92 Potion: where (57); details (57).
- 93 Pyre: where (596); details (729).
- 94 Relic: where (100); details (659).
- 95 Ring: where (226); details (760).
- 96 River: where (565); details (606).
- 97 Round Table: where (270); details (710).
- 100 Sack: where (753); details (786).
- 101 Sails: where (106); details (755).
- 102 Sandwich: where (616); details (820).
- 103 Secret Panel: where (328); details (873).
- 104 Seige Perilous: where (97); details (627).
- 105 Seiges: where (97); details (582).
- 106 Ships: where (275); details (789).
- 107 Shutters: where (119); details (566).
- 108 Snare: where (346); details (756).
- 109 Soup: where (40); details (606).
- 110 Stain: where (712); details (740).
- 111 Stool: where (335); details (623).
- 112 Sword: where (751); details (764).
- 115 Table Room: where (270); details (582).
- 116 Tree (Elm): where (592); details (703).
- 117 Tree (Apple): where (570); details (707).
- 118 Turquin's Manor: where (563); details (974).

Camelot/Logris Creatures, & People

- 119 Turret: where (625); details (730).
- 120 Weapons: where (764); details (764).
- 121 Willow: where (340); details (855).
- 122 Winch: where (390); details (971).
- 123 Window: where (324); details (620).
- 124 Wine: where (626); details (708).
- 125 Wood (Dead): where (312); details (654).
- 130 Agravaun: where (350); details (856).
- 131 Alice la Beale Pilgrim: where (797); details (958).
- 132 Aliduke: where (350); details (856).
- 133 Archers: where (758); details (774).
- 134 Army (Northgales): where (351); details (714).
- 135 Army (Roman): where (797); details (822).
- 136 Army (Tintagel): where (307); details (597).
- 137 Arthur: where (270); details (913).
- 140 Bear: where (346); details (567).
- 141 Beggar: where (290); details (582).
- 142 Black Knight: where (321); details (634).
- 143 Bors de Ganis: where (365); details (904).
- 144 Brachet: where (629); details (567).
- 145 Brandiles: where (350); details (856).
- 146 Breunis: where (323); details (709).
- 147 Brian: where (350); details (856).
- 150 Carter in Camelot: where (617); details (826).
- 151 Carter in Cornwall: where (630); details (826).
- 152 Colgreavaunce: where (963); details (905).
- 153 Constantine: where (647); details (638).
- 154 Crier: where (290); details (584).
- 155 Crowd: where (93); details (582).
- 156 Damosel Maledisant: where (349); details (713).
- 157 Damosel (Meliagaunt's): where (892); details (732).
- 158 Damosel (Meliot's): where (355); details (903).
- 159 Damosel (Turquin's): where (961); details (791).
- 160 Donkey: where (624); details (793).
- 161 Dragon: where (828); details (606).
- 162 Druid: where (624); details (883).
- 165 Ector de Maris: where (350); details (856).
- 166 Ector of Forest Sauvage: where (667); details (733).
- 167 Elaine: where (16); details (973).
- 168 Fox: where (797); details (567).

CAMELOT/LOGRIS CLUES

- 170 Galahad: where (598); details (959).
- 171 Gareth: where (350); details (856).
- 172 Garlon: where (670); details (591).
- 173 Gawain: where (680); details (904).
- 174 Geheris: where (350); details (856).
- 175 Ghost: where (975); details (975).
- 176 Giant Nabon: where (387); details (841).
- 177 Gnomes: where (655); details (906).
- 178 Green Knight: where (332); details (634).
- 179 Guard: where (388); details (955).
- 180 Guenever: where (930); details (912).
- 181 Hare: where (797); details (567).
- 182 Hawk: where (52); details (703).
- 183 Hawks: where (830); details (846).
- 184 Hellawes: where (302); details (893).
- 185 Herald: where (639); details (618).
- 186 Horses: where (768); details (768).
- 190 Ingrid: where (906); details (655).
- 191 Invisible Knight: where (670); details (591).
- 192 Kay: where (327); details (824).
- 193 King Alfred: where (961); details (840).
- 194 King Arthur: where (270); details (913).
- 195 King Mark: where (385); details (633).
- 196 King Pellam: where (827); details (839).
- 197 Knight (Black): where (284); details (634).
- 198 Knight (Green): where (332); details (634).
- 199 Knight (Magic): where (568); details (835).
- 200 Knight (Red): where (373); details (842).
- 201 Knight (White): where (346); details (634).
- 202 Knights (Queen's): where (656); details (668).
- 203 Knights (Thirty): where (302); details (715).
- 205 Lady near Elm: where (312); details (857).
- 206 Lady in Carriage: where (309); details (618).
- 207 Lamorak: where (673); details (904).
- 208 Lancelot: where (632); details (831).
- 209 Lionel: where (350); details (856).
- 210 Locusts: where (346); details (961).
- 211 Lynet: where (349); details (218).
- 215 Magic Knight: where (568); details (835).
- 216 Mark: where (385); details (633).
- 217 Maiden in Prison: where (294); details (952).
- 218 Maledisant: where (349); details (713).
- 219 Man+Snakes: where (568); details (631).
- 220 Marhaus: where (350); details (856).
- 221 Meliagaunt: where (360); details (994).
- 222 Meliot: where (355); details (909).
- 223 Merlin: where (657); details (833).
- 224 Mermaid: where (374); details (904).
- 225 Nabon: where (387); details (841).
- 226 Nimue: where (336); details (604).
- 230 Old Man: where (568); details (631).
- 231 Orkney People: where (285); details (990).
- 232 Peasants: where (391); details (582).
- 233 Palomides: where (716); details (894).
- 234 Pedivere: where (395); details (904).
- 235 Pellam: where (827); details (839).
- 236 Phelot: where (690); details (985).
- 240 Queen Eastlands: where (294); details (635).
- 241 Queen Guenever: where (930); details (912).
- 242 Queen Morgan: where (294); details (998).
- 243 Queen Northgales: where (294); details (635).
- 244 Queen Outisles: where (294); details (635).
- 245 Queen's Knights: where (656); details (668).
- 246 Red Knight: where (373); details (842).
- 247 Residents: where (285); details (990).
- 248 Rience: where (382); details (961).
- 250 Sentries in Cornwall: where (896); details (907).
- 251 Sentries in Orkneys: where (285); details (955).
- 252 Sesoines: where (136); details (136).
- 253 Someone Invisible: where (670); details (591).
- 254 Soothsayer: where (716); details (833).
- 255 Thirty Knights: where (302); details (715).
- 256 Toad: where (797); details (858).
- 257 Town Crier: where (290); details (584).
- 259 Tristram: where (311); details (920).
- 260 Turquin: where (953); details (962).
- 265 Whale: where (716); details (836).
- 266 White Knight: where (346); details (634).

Camelot/Logris Locations

- 270 Arthur's Castle: where (290); details (944).
- 271 Arthur's Hall: where (270); details (950).
- 272 Arthur's Seat: where (716); details (837).
- 273 Astolat: where (797); details (926).
- 275 Beach: where (585); details (941).
- 276 Bedroom/Boudoir: where (296); details (956).

CAMELOT/LOGRIS CLUES

- 277 Bedroom (Guest Room): where (296); details (939).
 278 Bedroom (Guenever's): where (923); details (963).
 279 Bedroom (Lancelot's): where (861); details (935).
 280 Bedroom (Merlin's): where (569); details (651).
 281 Bedroom (Morgan's): where (716); details (939).
 282 Bedroom (Perilous): where (305); details (743).
 283 Bishop's Gate: where (290); details (901).
 284 Black Launds: where (586); details (634).
 285 Broch: where (367); details (986).
 290 Camelot: where (607); details (918).
 291 Canterbury: where (797); details (936).
 292 Cathedral: where (290); details (851).
 293 Castle: Arthur's: where (290); details (944).
 294 Castle Chariot: where (570); details (951).
 295 Castle Lyonesse: where (351); details (960).
 296 Castle Meliagaunt: where (575); details (1010).
 297 Castle of Forest Sauvage: where (625); details (863).
 298 Castle Pellam: where (932); details (937).
 301 Castle (Wailing): where (866); details (692).
 302 Chapel Perilous: where (641); details (919).
 303 Clearing with Apple Tree: where (570); details (707).
 304 Coast Road: where (571); details (658).
 305 Corbin Castle: where (306); details (1001).
 306 Corbin Village: where (969); details (1020).
 307 Cornwall: where (625); details (925).
 308 Country Junction: where (862); details (658).
 309 Crossroads: where (608); details (843).
 310 Dungeon of Castle Chariot: where (294); details (952).
 311 Dungeon of Tintagel: where (385); details (942).
 312 Elm Tree: where (592); details (703).
 320 Folly: where (716); details (863).
 321 Ford: where (572); details (634).
 322 Forest Road: where (625); details (658).
 323 Forest Maze: where (785); details (770).
 324 Garden: where (844); details (620).
 325 Gate (Bishop's): where (290); details (901).
 326 Gate (King's): where (290); details (901).
 327 Gate (Serfs'): where (607); details (910).
 328 Gateway of Turquin's Manor: where (978); details (999).
 329 Gaul: where (590); details (1018).
 330 Glastonbury: where (336); details (964).
 331 Grail Lands: where (989); details (989).
 332 Green Launds: where (660); details (634).
 333 Guardroom: where (902); details (915).
 334 Guenever's Room (Castle Meliagaunt): where (296); details (956).
 335 Guenever's Bedroom: where (923); details (936).
 336 Isle of Avalon: where (796); details (716).
 337 Isle of Servage: where (996); details (1000).
 340 Joyous Gard: where (716); details (742).
 341 King's Gate: where (290); details (901).
 342 Lancelot's Bedroom: where (861); details (935).
 343 Launds (Black): where (845); details (634).
 344 Launds (Green): where (660); details (634).
 345 Launds (Red): where (610); details (634).
 346 Launds (White): where (716); details (634).
 347 Library: where (587); details (561).
 348 Listinoise: where (625); details (966).
 349 Logris: where (794); details (794).
 350 Lower Prison: where (971); details (997).
 351 Lyonesse: where (776); details (295).
 355 Manor (Meliot's): where (661); details (943).
 356 Manor (Turquin's): where (563); details (974).
 357 Marsh: where (573); details (932).
 358 Marsh Road: where (625); details (967).
 359 Maze: where (785); details (770).
 360 Meliagaunt's Castle: where (575); details (1010).
 361 Meliagaunt's Guest Room: where (360); details (979).
 362 Merlin's Guest Room: where (569); details (651).
 363 Mews: where (609); details (642).
 364 Mosaic: where (716); details (815).
 365 Nabon's Tower: where (379); details (1002).
 366 Northgales: where (790); details (790).
 367 Orkneys: where (643); details (1003).
 370 Perilous Bedroom: where (305); details (743).
 371 Prison (Lower): where (971); details (997).
 372 Prison (Upper): where (816); details (1011).
 373 Red Launds: where (610); details (634).
 374 Rock: where (931); details (968).
 375 Round Table Hall: where (270); details (710).
 376 Sea: where (777); details (1004).
 377 Secret Passage: where (812); details (1019).

THE GRAIL QUEST CLUES

- 378 Serfs' Gate: where (607); details (910).
 379 Servage: where (996); details (1000).
 380 Sesoine Ship: where (275); details (789).
 381 Shore: where (847); details (1004).
 382 Stepping Stones: where (340); details (813).
 383 Study: where (829); details (1014).
 385 Tintagel: where (864); details (1025).
 386 Tower (Elaine's): where (306); details (1007).
 387 Tower (Nabon's): where (379); details (1002).
 388 Tower in Orkneys: where (367); details (986).
 389 Turquin's Manor: where (563); details (974).
 390 Upper Prison: where (816); details (1011).
 391 Village: where (607); details (606).
 395 Wailing Castle: where (866); details (692).
 396 Warship: where (275); details (789).
 397 Westminster Meadows: where (575); details (1017).
 398 Windmill: where (716); details (1009).
 399 Windsor: where (817); details (970).
 425 Dagger: where (818); details (797).
 426 Dead Body: where (645); details (849).
 427 Dune: where (577); details (1024).
 430 Fire Wall: where (541); details (1030).
 432 Holy Grail: where (1005); details (838).
 433 Horn: where (412); details (684).
 434 Key: where (511); details (1006).
 435 Mead: where (421); details (588).
 436 Mistletoe: where (506); details (1022).
 440 Pavilion: where (810); details (877).
 441 Plate: where (467); details (691).
 442 Potato: where (616); details (782).
 443 Purse: where (466); details (802).
 444 Sand: where (427); details (1032).
 445 Shield: where (510); details (801).
 446 Sickle: where (797); details (874).
 447 Sword: where (412); details (801).
 450 Thicket: where (612); details (695).
 451 Thorn Tree: where (589); details (806).
 452 Tomb: where (510); details (772).
 453 Wall of Fire: where (541); details (1030).
 454 Water: where (1015); details (1038).
 455 Well: where (579); details (672).
 456 Wind: where (693); details (693).

The Grail Quest General Clues

- 400 Beginning the Quest (734).
 401 Finding Things (725).
 402 Finding the Holy Grail (938).
 403 Game background (759).
 404 Going Places (737).
 405 Orders to People (867).
 406 Score (911).
 407 Solution of Grail Quest (938).

The Grail Quest Objects

- 410 Altar: where (547); details (663).
 411 Bed: where (440); details (735).
 412 Boat: where (513); details (895).
 413 Body: where (645); details (849).
 414 Brooch: where (466); details (688).
 415 Cakes: where (467); details (745).
 416 Chalice: where (495); details (1013).
 417 Cheese: where (647); details (665).
 418 Cross (near Vagon): where (572); details (576).
 419 Cross (in wasteland): where (762); details (576).
 420 Crown: where (418); details (644).
 421 Cup: where (809); details (739).

The Grail Quest Creatures & People

- 460 Adder: where (716); details (749).
 461 Angels: where (531); details (875).
 462 Black Dragon: where (720); details (803).
 463 Black Knight: where (526); details (686).
 464 Bors de Ganis: where (511); details (748).
 465 Cleric: where (578); details (696).
 466 Dagonet: where (647); details (718).
 467 Damosel: where (540); details (763).
 468 Devils: where (682); details (876).
 469 Dragon (Black): where (720); details (803).
 470 Dragon (Red): where (720); details (803).
 471 Dust Elemental: where (1012); details (1012).
 472 Dwarf: where (527); details (721).
 475 Ector de Maris: where (527); details (721).
 476 Elementals: where (1012); details (1012).
 477 Fiend: where (452); details (804).
 478 Fiends: where (679); details (798).

ANSWERS

- 479 Fire Elemental: where (1012); details (1012).
 480 Follower of Nacien: where (518); details (637).
 481 Galahad: where (880); details (890).
 482 Hermit: where (532); details (646).
 483 Joseph of Aramathea: where (531); details (648).
 485 Knight (Black): where (526); details (686).
 486 Knight (Woodland): where (805); details (738).
 487 Knights (Barbarous): where (676); details (722).
 488 Lancelot: where (632); details (831).
 499 Lions: where (868); details (807).
 490 Maiden: where (527); details (721).
 491 Monks: where (578); details (696).
 492 Mordred: where (716); details (723).
 495 Nacien the Hermit: where (532); details (646).
 500 Percival: where (511); details (748).
 501 Pilgrim: where (613); details (672).
 502 Preacher: where (515); details (769).
 503 Priests: where (613); details (696).
 505 Red Dragon: where (720); details (803).
 506 Swan: where (647); details (858).
 507 Water Elemental: where (1012); details (1012).
 508 Woodland Knight: where (805); details (738).

The Grail Quest Locations

- 510 Abbey: where (579); details (788).
 511 Antechapel: where (589); details (1012).
 512 Avalon: where (796); details (716).
 513 Bleak Shore: where (871); details (886).
 514 Castle; Vagon: where (699); details (663).
 515 Church: where (766); details (929).
 516 Clearing with Dragon: where (546); details (803).
 517 Clearing with Pavilion: where (810); details (877).
 518 Cliff Path: where (1037); details (637).
 519 Courtyard: where (647); details (701).
 520 Cross near Vagon Castle: where (572); details (576).
 521 Cross in Wasteland: where (762); details (576).
 522 Dark Shore: where (933); details (1027).
 523 Dark Valley: where (933); details (1023).
 525 Fair: where (647); details (800).
 526 Ford: where (614); details (686).
 527 Forest Ride: where (594); details (721).
 530 Glades: where (1026); details (1031).
 531 Heaven: where (647); details (872).
 532 Hermitage: where (724); details (815).
 533 Hillock: where (546); details (870).
 534 Horses: where (768); details (768).
 535 Isle of Sand: where (1029); details (649).
 536 Isle of Turnance: where (927); details (1033).
 537 Lindisfarne: where (647); details (773).
 540 Pavilion: where (810); details (877).
 541 Sand Isle: where (1029); details (649).
 542 Sea: where (674); details (681).
 543 Shore; Bleak: where (871); details (886).
 544 Shore; Dark: where (933); details (1027).
 545 Temple: where (647); details (787).
 546 Turnance Isle: where (927); details (1033).
 547 Vagon Castle: where (699); details (663).
 548 Valley: where (658); details (1023).
 550 Well: where (579); details (672).
 551 White Abbey: where (579); details (788).
 552 Woodland: where (658); details (1023).

Answers

- 560 Best ignored; contains a potion.
 561 Read the books for clues.
 562 Atop an Orkney mountain.
 563 North from the junction; West of the crossroads.
 564 Wave to open the drawbridge.
 565 Flows across the ford.
 566 Use against the Invisible Knight. See (580).
 567 Follow it.
 568 Appears when Lancelot lies on the bed (24).
 569 North of Merlin's study (383).
 570 Beyond the Briers (30).
 571 East of the crossroads.
 572 East of where Lancelot starts.
 573 North of the marsh road (357).
 574 Wait, and she turns back from rock.
 575 South from the Bishop's Gate.
 576 Examine it for a hint.
 577 Beyond the Fire Wall. See (621).
 578 Wandering about.
 579 South of cross in the wasteland.
 580 All are equal in the dark (599).
 581 Worn for protection against arrows.

ANSWERS

- 582 Takes no part in the game.
 583 Examine for its contents.
 584 Follow for hints.
 585 Beyond the sentries (250).
 586 North of the country junction.
 587 East of Merlin's study (383).
 588 Honey wine. Can be drunk.
 589 East of the bleak shore.
 590 Corbin's land. Use the boat (28).
 591 A murderer who attacked while invisible. But his power could be countered. See (580).
 592 North, past Turquin's Manor.
 593 Can only be slain by a woman.
 594 East from wasteland cross (520).
 595 Travelled between Camelot and Castle Meliagaunt.
 596 In Camelot, after Meliagaunt has challenged Lancelot.
 597 Invading Sessoinnes, who block Lancelot. Deal with their source of supply. See (275).
 598 Son of Lancelot and Elaine (167).
 599 In the Turret, close the (107).
 600 Drink to be healed.
 601 Travels to and from the beach.
 602 Closed until late in this part, after the May celebrations.
 603 In the western sea (619).
 604 The Damosel of the Lake, loved by Merlin. She lures him under a rock.
 605 Downstairs in the Broch - Orkney Tower (285).
 606 Just scenery.
 607 East of the ford (321).
 608 In Logris, North of the King's Gate.
 609 In Camelot, East and North of the Serf's Gate.
 610 North of the Green Launds.
 612 Southeast of the cross (418).
 613 Wanders about.
 614 East of the pavilion.
 615 Needed by a harpist (259).
 616 Not invented yet.
 617 Travels between Camelot & Castle Meliagaunt.
 618 Appears but briefly.
 619 Not in this game.
 620 Desperate strength is needed to bend the bars. See (636).
 621 Co-operation is needed to extinguish it. See (662).
 622 Take to Meliot to cure him. (302).
 623 The only weapon to hand. (977).
 624 Not in this game.
 625 West from the crossroads.
 626 Keep when Queen Morgan offers it in the dungeon. Then see (640).
 627 Galahad's seat at the Round Table. Plays no part in the game.
 628 Pulled to release the chains of the prisoners below.
 629 East of the country junction.
 630 Travels to/from the beach (250).
 631 Apparition described by Malory.
 632 Here. You play Lancelot.
 633 Bad king, not directly in the game. See (259).
 634 Fight and spare the knight.
 635 Do not choose any queen.
 636 Lancelot could enter once Guenever had invited him for the night.
 637 The people with warnings were only illusions.
 638 King who ruled after Arthur.
 639 Met on the road.
 640 Offer the wine to (217).
 641 South of the manor (355).
 642 Not the best place to sleep. (362).
 643 North from the crossroads.
 644 Avoid temptation by leaving it.
 645 Discovered once the fiend had fled.
 646 Ignore him on the path — this was an illusion. Visit his hermitage for advice.
 647 Not in this game.
 648 Said to have brought Christianity to Britain.
 649 Tackle the fire to reach (444).
 650 Used to forge the Grail sword.
 651 Sleep here, not in the mews.
 652 Blocks Castle Chariot. See (669).
 653 Used to carry the coals.
 654 Has a use. See (666).
 655 Gnome Ranger and Ingrid's Back!
 656 Turn up in Castle Meliagaunt.
 657 In his house in Camelot.
 658 Scenic location.
 659 Use to defeat the giant. See (698).

ANSWERS

- 660 North of the Black Launds.
 661 Follow the brachet.
 662 Fill two containers with water – (416) and (421). See (675).
 663 Show respect before leaving (678).
 664 Fight and spare the knight. Then (677).
 665 Feed to the (160).
 666 Use to defeat Phelot. See (698).
 667 In the Castle of Forest Sauvage.
 668 Guarding Guenever.
 669 You need help to cut them (685).
 670 Near the turret (119).
 671 Rescued knights obey you. So does the Red Knight, if spared. See (683).
 672 See (416) to get water. See (689).
 673 Imprisoned in the Broch (285).
 674 East of the bleak shore.
 675 Get Galahad to repeatedly fill and throw a container. Lancelot does this simultaneously.
 676 Arrive and capture Galahad.
 677 To Camelot and find somewhere to sleep (22). Then (687).
 678 Pray.
 679 Often disguised. They are (467), (502), and, more powerful, (477).
 680 Imprisoned in Castle Chariot.
 681 Lake Mortaise in the original. May be death/purgatory. Sail in Boat (412) to (546), (541), and (544).
 682 In the detail. See (679).
 683 They are (246), (143), (173), (207), (222) who leaves; (234), (259), (170) who you cannot yet meet; and nine imprisoned in (389).
 684 Blow to summon wind for the (412).
 685 Get someone to repeatedly cut the Briers. Simultaneously, Lancelot does this too.
 686 To get past, see (694).
 687 Visit Arthur, then (697).
 688 Take this treasure and see (689).
 689 Give it to the pilgrim.
 690 Arrived when hawk had been freed.
 691 Does nothing in itself.
 692 Kill Breunis to free Pedivere.
 693 Blow the horn to summon one.
 694 Do not carry anything.
 695 Scenery; difficulties of faith.
 696 To make the place look occupied.
- 697 Free imprisoned knights in Logris.
 698 Throw it at him.
 699 Where Lancelot starts.
 700 Hit the drawbridge with it.
 701 Lie on this several times.
 702 Push off the trapdoor. See (717).
 703 Climb and free the hawk. Then worry about Phelot.
 704 Needed to use the anvil.
 705 Blow at Lyonesse to summon the Captain. When blown, this can be heard from a distance. See (711).
 706 Pour into the wine and see (250).
 707 Scenery. But see Queen Morgan (242).
 708 Take but don't drink. See (719).
 709 Evil knight. Follow and kill him.
 710 Not used directly; but you must free the knights to sit here.
 711 Use to regain your bearings (357) and to synchronize actions (for example, type KNIGHT, WAIT FOR HORN).
 712 After Lancelot breaks the bars.
 713 Follows and reports your deeds to Arthur.
 714 Blow the horn.
 715 Ignore their threats.
 716 Not in this game.
 717 Two must push simultaneously.
 718 King Arthur's jester.
 719 Offer to the damosel.
 720 In a clearing on Turnance (731).
 721 Immediately rescue the captives, going after (490) first.
 722 Fight on, regardless.
 723 Arthur's illegitimate son.
 724 Up the cliff path. See (637).
 725 Type FIND THING; GO TO PLACE; RUN TO PLACE; or FOLLOW SOMEONE.
 726 Burning hot. See (736).
 727 Take to swap later. See (379).
 729 Defeat Meliagaunt to free Guenever.
 730 Home of the Invisible Knight and where he can be defeated.
 731 Three locations from the hillock; one is north and the other south.
 732 Refuse to bargain away honour until she lowers her price.
 733 Visit for information.

ANSWERS

- 734 Consider (410), then (744).
 735 Avoid temptation; leave it alone.
 736 Carry them in (40). Then, see (747).
 737 EXITS shows the directions you can go; EXITS ON shows this after every move. To move, type compass directions. See (725).
 738 Honesty is best. Then see (722).
 739 Container to fill with (444)/(454).
 740 From Lancelot's injury. Proves someone slept here. Cannot be hid.
 741 Can only enter at Guenever's specific request.
 742 Lancelot's own island castle.
 743 Lie on the Bed and apparitions appear. See (215), (230).
 744 Ignore the crown. Visit the church (502). Then see (478).
 745 If you like, eat just one.
 746 Light robs power from the fiends.
 747 Put them on the (101).
 748 Grail knight. Helped get key.
 749 Bit to start Arthur's last battle.
 750 You score 200 each for: ensuring all the Round Table knights can join and are not imprisoned (06); reaching places listed in (761); and solving puzzles associated with (771).
 751 Worn by Lancelot.
 752 Look in it when fighting (184).
 753 Below Nabon's head. To get it, see (765).
 754 Outside tower in Corbin.
 755 Tinder dry. See (767).
 756 Put on the ground to catch (181).
 757 Wanders in the forest maze.
 758 Westminster Meadows after Guenever invites Lancelot to celebrate May.
 759 Lancelot must avoid all sins if he is to reach the Holy Grail.
 760 Wear it to see invisible things.
 761 Marsh Isle; Meliagaunt's Prison; (119); (271); (275); (276); inside (285); (310); (332); (335); (337); (342); (347); inside (356); inside (360); (370); (375); (378); (383); and (395).
 762 East; past the Woodland Knight.
 763 Do not trust her. See (775).
 764 Always with Lancelot, except when he climbs the Elm (703) or says farewell at the end (795).
 765 Replace it instantly; see (778).
 766 NE and N from the cross (521).
 767 Put (44) on them.
 768 There when needed.
 769 Do not trust him. See (783).
 770 Don't explore. Just slay (146).
 771 Finishing *Camelot/Logris*: (93); (275); (276); (305); (312); (321); (347); (350); and (351).
 772 Don't open it yourself. See (784).
 773 Holy Island, off northeast England.
 774 Cannot be avoided. Afterwards, use alternative transport (38).
 775 Eat a cake if you like, then (791).
 776 For game purposes, placed in North Wales, beyond all the Launds.
 777 Beyond the shore.
 778 Replace with (85). See (792).
 779 Use a different weapon. See (50).
 780 Wear to hide any wound. See (27).
 781 Give to the damosel in order to escape.
 782 Cook it in the fire, then eat it.
 783 Leave the crown alone; then (791).
 784 Galahad can. Then tell him to kill the occupant.
 785 North of the forest road.
 786 Once obtained (765), look inside.
 787 Dig to find the relic.
 788 Heed the warnings on objects here.
 789 To defeat the invaders; see (799).
 790 For game purposes, assumed to be North Wales (where there are many Arthurian sites).
 791 Make the sign of the cross.
 792 Tell someone to wait, and put the replacement under him. Take the sack, simultaneously.
 793 Ride this if your horse is slain.
 794 Arthur's Realm. Use King's Gate.
 795 See (56) and (335).
 796 Mythical Isle in the west; a valley in northeast Somerset.
 797 Not in this game.
 798 In disguise. To banish, see (791).
 799 Destroy them, using (44).
 800 Source of fire, to light (50).
 801 Get Galahad to take it.
 802 Offer to the preacher.
 803 Do not fight. See (821).
 804 Too powerful to dispell in the usual way (791). Lancelot cannot defeat it, but see (784).
 805 South of the thicket.

ANSWERS

- 806 Scenery, but the real Glastonbury Thorn may be grown from a cutting of the tree sprouted from Joseph's staff. It flowers near Christmas.
- 807 Trust in the Lord and pay no heed.
- 808 Shore, East of the coast road.
- 809 Reward for slaying the dragons with minimum effort. See (821).
- 810 Beyond the Woodland Knight.
- 811 Kept Elaine on the boil. See (167).
- 812 Beyond the secret panel.
- 813 Causeway to the isle.
- 814 Free the knights (683) and return to Arthur. Then see (823).
- 815 Visit for advice.
- 816 In the Middle of Turquin's Manor.
- 817 Complete this part of the game and the action continues with the quest for it.
- 818 Floating on the river.
- 819 Between London and Winchester.
- 820 Curling at the edges.
- 821 The red and black dragons predate *Le Morte D'Arthur* (like many of its tales) and originate in the Mabinogion. The dragons dislike each other. See (832).
- 822 Defeated by Arthur; when he took Rome. Lancelot was a commander.
- 823 Rescue Guenever from Meliagaunt. Accept her invitation and rescue her again. Then see (834).
- 824 Arrogant knight. Ignore him.
- 825 To defeat Nabon, you need (100).
- 826 See details of his cart.
- 827 In a hidden castle in the marsh.
- 828 Chapel in Corbin.
- 829 In Merlin's house in Camelot. From the Serf's Gate, E, E, N, N, W, W, -W, N, Up.
- 830 Hidden in the mews. Sleep there to discover them.
- 831 Best knight for most of Arthur's reign.
- 832 Bring them together. See (848).
- 833 Provider of hints and rescues.
- 834 Visit Guenever to say goodbye and defeat the ambushing knights.
- 835 Fight him. To win, see (83).
- 836 Leviathan, who pretends to be an Island. See (337).
- 837 Impressive summit in Edinburgh.
- 838 Item of dinnerware at Last Supper.
- 839 Wounded "fisher" king (one of four in *Morte D'Arthur*—probably a bug). Visit him for a hint.
- 840 King who ruled much later than Arthur, but with similar problems.
- 841 Evil giant who must be slain. See (100).
- 842 Fight and spare him. He helps later.
- 843 Central point on the map.
- 844 Beside Castle Meliagaunt.
- 845 North of the country junction.
- 846 The reason to sleep somewhere else.
- 847 East of the coast road.
- 848 From the hillock, type: GALAHAD, N, N, N, S, S, S, then S, S, S, N, N, N.
- 849 Focus for the Fiend. Leave alone.
- 850 The historical Arthur was a fifth century war leader in southwest Britain. Tales grow and change in the telling and, when Malory came on the scene a millenium later, there was a great diversity of stories in Britain and France. Malory imposed his own structure, where Arthur is the still centre to whom tales are told. Lancelot, in contrast, is the active knight: supreme in combat, tragic lover of Queen Guenever, and the only worldly knight to touch the Holy Grail. See (860).
- 851 Basically scenery.
- 852 Get in; then move as normal to travel by water. And see (869).
- 853 Wave to confuse your opponent.
- 854 Trigger the crossbow trap when anyone goes north. See (873). If asked if Lancelot wants to jump back, see (899).
- 855 Look in its branches.
- 856 Round Table knight. See (865).
- 857 Do as she asks. See (182).
- 858 Get Elaine to kiss it.
- 859 Don't wear it; you'd look silly.
- 860 Lancelot was the obvious hero for this game and we stuck as near as possible to Malory. But three types of change were desirable. First, *Le Morte D'Arthur* is a collection of several "books", in some of which Lancelot doesn't appear. So, we've given a few of the deeds of other knights to Lancelot. Second, we've emphasised the theme of completing the Round Table. And, finally, the game stops at its high point; the achievement of the Holy Grail; rather than continuing to the death of Arthur.
- 861 Lancelot was returned here once the Round Table was complete.
- 862 North from the elm tree.
- 863 Go inside for a chat.

ANSWERS

- 864 Cornwall, beyond the army (597).
- 865 Cannot be freed unless Lancelot has first dealt with (73). There is no time to free all the knights individually. See (879).
- 866 In the forest maze. Follow Breunis.
- 867 Galahad will obey orders once the mainland is free of evil. See (878). Knights in the Antechapel accept some orders later.
- 868 Just before the Grail.
- 869 When anyone moves in the boat, it moves. This helps with the (224).
- 870 Midway between the dragons (821).
- 871 East of the forest ride.
- 872 Destination of all Grail knights.
- 873 To destroy the trap, you must get through the secret panel (885) to the secret passage (377).
- 874 Use to get the (436).
- 875 Help if Galahad attacks the fiend.
- 876 Necessary consequence of unfettered free will.
- 877 Take care of the damosel. See (763).
- 878 Avoid sins and solve the problems associated with (515), (508), (540), (495), (550), (490), (464), and (487).
- 879 Free one knight; tell him to free the next four; tell one of these to free the next three and so on. Then see (888).
- 880 Wandering about.
- 881 Hide when the guard passes to (18).
- 882 Can only be cut with the axe.
- 883 Merlin in disguise.
- 884 Comic anti-heroine.
- 885 Tell someone to wait and hold the panel so it doesn't close. Then stand on the planks to trigger the trap and go inside.
- 886 Sail in the boat. See (895).
- 887 Opens to admit the Magic Knight. To defeat him, see (891).
- 888 The only way out is in the cage. You should first have arranged for someone to wait above and turn the winch at the right time. See (66).
- 889 Get inside and wait. Eventually it arrives on the beach.
- 890 New best knight and the only one worthy to solve several problems. See (867) to recruit him and (898) for more information.
- 891 While it's open, he can be healed. See (897).
- 892 Meliagaunt's prison.
- 893 Ignore her threats and take (43).
- 894 Infidel knight. Accept his gift.
- 895 Works as earlier boat, but Lancelot is not worthy to move it himself. See (481). For wind, see (433). Don't take the sword.
- 896 Block the way to the Sesoines' ships. To pass, see (39).
- 897 Keep closing it until it shuts.
- 898 Get him to solve problems linked with (551), (412), (536), (535), (511).
- 899 The floor is one end of a see-saw and tips up unless someone is waiting in (377).
- 900 East to the ford (634), then go to Camelot. Ignore Kay and see (908).
- 901 Closed on the first day. Find somewhere to sleep, then return.
- 902 North of the Upper Prison.
- 903 Tends wounded Meliot.
- 904 Round Table knight. Once freed, can be asked to help.
- 905 Defeat him. See (914).
- 906 Go out and buy a copy! (C&VG).
- 907 Get past; using (39).
- 908 Find Merlin and somewhere to sleep (22). Then to the library (29) and find Arthur. See (916).
- 909 Round Table knight. Bring the cloth to cure him.
- 910 Provides access to Camelot.
- 911 You score 100 for reaching places listed in (922); 200 for solving puzzles associated with (945); and 100 for reaching the Grail. There are penalties for committing sins.
- 912 The Queen, Arthur's wife, who was loved by Lancelot. For what to do at the start see (921). When invited to celebrate May, see (928). In Castle Meliagaunt, see (940). When challenged over her honour, see (948).
- 913 King of England, but he plays no great part in the game.
- 914 Get a weapon (56) and hit him.
- 915 Keep clear.
- 916 To Logris and ensure all the Round Table knights are free to join it. See (683), (924).
- 917 Escape from prison. See (157) and find the queen. Then see (729).
- 918 Arthur's capital.
- 919 Ignore all threats; take the cloth.
- 920 Round Table knight and expert musician. Take him the (62).
- 921 Visit Arthur and Guenever in the castle. Then ride off through the King's Gate to Logris to rescue Arthur's knights and complete the Round Table. Return to Guenever.

ANSWERS

- 9 2 2 (517), (540), (521), (532), (551), (535), (536), (544), (499), and the corridor leading to the Grail.
- 9 2 3 Visit, at the end, from Lancelot's bedroom, to say "Goodbye".
- 9 2 4 Back to Arthur. Accept Guenever's offer and rescue her (948). Then see (935).
- 9 2 5 Defeat Sessoinnes; enter Tintagel.
- 9 2 6 Town near Reading, where another Elaine lived.
- 9 2 7 At sea, Southeast of the shore.
- 9 2 8 South from Camelot, past the archers (774), and into Castle Meliagaunt. See (934).
- 9 2 9 Look at the preacher. See (769).
- 9 3 0 Various places.
- 9 3 1 At sea, SE and S from the shore.
- 9 3 2 Castle Pellam is hidden in the marsh. For orientation, get a knight to move away. See (66).
- 9 3 3 At sea; east of the bleak shore.
- 9 3 4 Spare Meliagaunt and go straight to Guenever.
- 9 3 5 Visit Guenever to say goodbye. Escape the resulting difficulty; see (335); and that's it.
- 9 3 6 Chief cathedral city of Logris.
- 9 3 7 Visit for a clue.
- 9 3 8 Begin the quest (400) and solve the problems to prove your worth to Galahad (867). See (949).
- 9 3 9 Consider the contents of the chest.
- 9 4 0 When Guenever invites Lancelot to return that night, go around and in by the (324). In the morning, leave immediately and see (947).
- 9 4 1 Destroy the ships. See (44).
- 9 4 2 All can be freed by Tristram (920).
- 9 4 3 Help Sir Meliot. See (909).
- 9 4 4 If locked, see (901). Visit to be knighted and return when Lancelot is best knight.
- 9 4 5 (502), (467), (490), (475), (501), (542), (412), (536), (434), and (511).
- 9 4 6 Consider the objects here.
- 9 4 7 Don't let the injury be seen (58) and return to Guenever. See (948).
- 9 4 8 When she is led away, start to leave the castle. See (917).
- 9 4 9 Solve the problems associated with (551), (412), (536), (535), and (511). Then head steadfastly to the Grail.
- 9 5 0 Visit to meet Arthur or Guenever.
- 9 5 1 Wait outside, not choosing any of the queens. Then see (310).
- 9 5 2 Accept Morgan's gift. See (708).
- 9 5 3 Challenges you outside his manor.
- 9 5 4 Alternative transport. See (965).
- 9 5 5 Light the beacon to decoy the Broch's guard. See (285).
- 9 5 6 Room commandeered by Guenever in Castle Meliagaunt. See (940).
- 9 5 7 Constellation in northern sky.
- 9 5 8 Wife of Alisander le Orpheelin.
- 9 5 9 This adventure is unusual in that it spans many years; long enough for Lancelot's son Galahad to be conceived, born, and come of age. He is essential to complete the Round Table, so bear this in mind when meeting his mother (167).
- 9 6 0 Deal with the army; see (66); then enter to meet Dame Lyonesse.
- 9 6 1 Not in this game.
- 9 6 2 Fight him, then go inside (356).
- 9 6 3 A group of knights, led by Mordred, seized their opportunity to catch Lancelot with Guenever and prove his adultery. Lancelot was not armed but had to fight. See (977).
- 9 6 4 Site of the formerly most important monastery in Britain.
- 9 6 5 Get into it and wait to be taken past the archers to the castle.
- 9 6 6 Land of mists and marshes.
- 9 6 7 The marsh is north. See (357).
- 9 6 8 You need the harp. See (224).
- 9 6 9 East of the sea. Use the boat (28).
- 9 7 0 Where a hermit lived; in the book.
- 9 7 1 The cage travels between the Upper and Lower Prisons when the winch is turned. See (980).
- 9 7 2 Lure the guard away with (18).
- 9 7 3 Rescued by Lancelot; if he has achieved enough to be worthy. Accept her invitation. See (982).
- 9 7 4 Turquin has captured nine knights. Defeat him first, then solve the gateway problems (328) and descend to the Lower Prison (350).
- 9 7 5 Look out for "Scapeghost".
- 9 7 6 Take her harp. See (984).
- 9 7 7 Let in just one knight. See (991).
- 9 7 8 In the manor. Defeat Turquin first.
- 9 7 9 Visit to get the glove.
- 9 8 0 Get into the cage to travel with it. See (987).
- 9 8 1 Triggered by the loose planks. You need to destroy it, so see (873).
- 9 8 2 When inside Corbin Castle, remember Lancelot's honour (988).
- 9 8 3 Remember Lancelot's honour (993).

ANSWERS

- 9 8 4 Move away instantly; get someone else to arrange it. See (869).
- 9 8 5 Improvise a weapon (50).
- 9 8 6 Circular stone tower; passages within its walls. To enter, see (18). Once inside, see (995).
- 9 8 7 Travel down is simple; but, to go back up you must have left someone behind to turn the winch. See (888).
- 9 8 8 Sleep in the perilous bedroom (743).
- 9 8 9 Finish this part of the game. See (03).
- 9 9 0 Attack if Lancelot stays in their tower (Broch) for too long.
- 9 9 1 Tell Guenever to wait; close the door. Then open it. One knight is trapped. See (914).
- 9 9 2 The loose floor works as a see-saw. Jump back, unless there is someone in (377) to balance it.
- 9 9 3 Wait until she no longer requires Lancelot to give up Guenever. Then kiss her.
- 9 9 4 False knight; don't kill him until the meeting in Camelot. See hints for Castle Meliagaunt and the rooms and objects therein.
- 9 9 5 Descend to the cellar; free the captive and escape; see (42).
- 9 9 6 At sea; roughly NE of the shore.
- 9 9 7 Free the knights; see (865).
- 9 9 8 Do not choose her and refuse her offers. See (708).
- 9 9 9 Disable the crossbow trap (981); then go North (992).
- 1 0 0 0 Kill Nabon and free his prisoner.
- 1 0 0 1 Cannot enter unless invited by Elaine. Then see (982).
- 1 0 0 2 Defeat Nabon. Get (85), then see (841).
- 1 0 0 3 Rescue a knight from the Broch Tower.
- 1 0 0 4 Travel in the boat (28).
- 1 0 0 5 Beyond the antechapel.
- 1 0 0 6 Needed to open the east door from the antechapel. See (1012).
- 1 0 0 7 Rescue Elaine, if you're worthy.
- 1 0 0 8 Someone must wait here to balance the floor beyond the gateway (328).
- 1 0 0 9 Hardly common at this date.
- 1 0 1 0 Closed until late in the game, after Guenever's invitation to celebrate May. See (928).
- 1 0 1 1 Avoid the guardroom to the north, but travel to the Lower Prison and rescue the knights there.
- 1 0 1 2 When Lancelot takes the key, Elementals appear; they must be negated. See (1021).
- 1 0 1 3 A container. Can be filled with (444) or (454) but, before this, give it to (501).
- 1 0 1 4 Room in Merlin's house.
- 1 0 1 5 Sea etc.
- 1 0 1 6 Wait here for the dwarf to return.
- 1 0 1 7 To pass the archers, see (774).
- 1 0 1 8 Where Corbin lies.
- 1 0 1 9 Smash the crossbow and see (1008).
- 1 0 2 0 Read the Inscription and visit Elaine. Rescue her if your score is good enough. After this, enter Corbin Castle (305).
- 1 0 2 1 This requires co-operation. Tell the Grail knights to wait and do the right things when Lancelot takes the Grail. See (1028).
- 1 0 2 2 Magical plant. A sign of the Grail.
- 1 0 2 3 Basically just scenery.
- 1 0 2 4 Fill container with sand.
- 1 0 2 5 Castle of King Mark. To enter, see (136). To leave, Tristram will help.
- 1 0 2 6 North and South of forest ride.
- 1 0 2 7 Look around.
- 1 0 2 8 Throw water (from a container) at the Fire Elemental; see (1034).
- 1 0 2 9 At sea, roughly NE of the shore.
- 1 0 3 0 Extinguish it. See (1036).
- 1 0 3 1 Visit the night one first (721).
- 1 0 3 2 Fill container; throw it at (507).
- 1 0 3 3 Dragons live here. See (803).
- 1 0 3 4 Throw (444) at the Water Elemental and, finally, use (433).
- 1 0 3 5 Polish it to summon (175).
- 1 0 3 6 Give a container – (416) or (421) – to Galahad and tell him to fill it and throw the water repeatedly. Meanwhile, Lancelot does similarly.
- 1 0 3 7 North of cross in the wasteland.
- 1 0 3 8 Use to extinguish wall of fire. Fill container; throw at (479).

CAMELOT CITY/CASTLE MELIAGAUNT MAPS

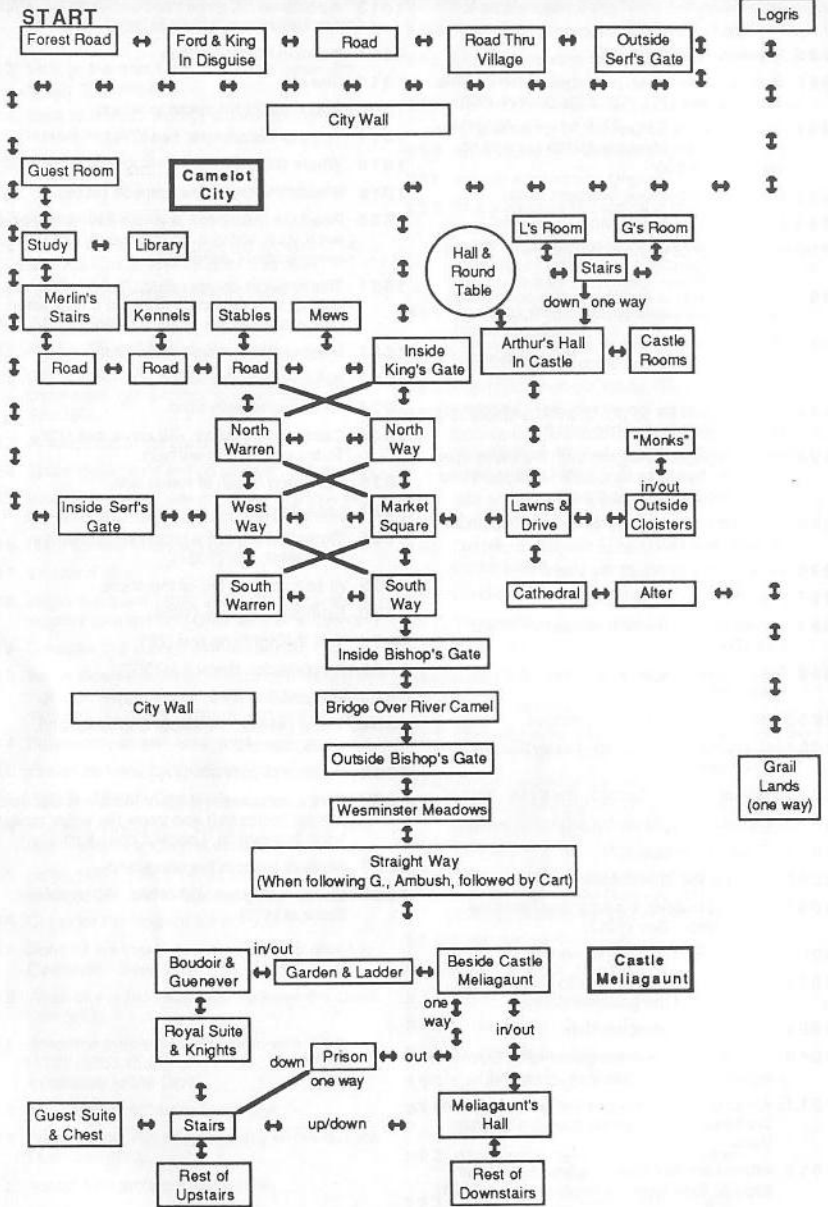

CENTRAL LOGRIS/CORNWALL MAPS

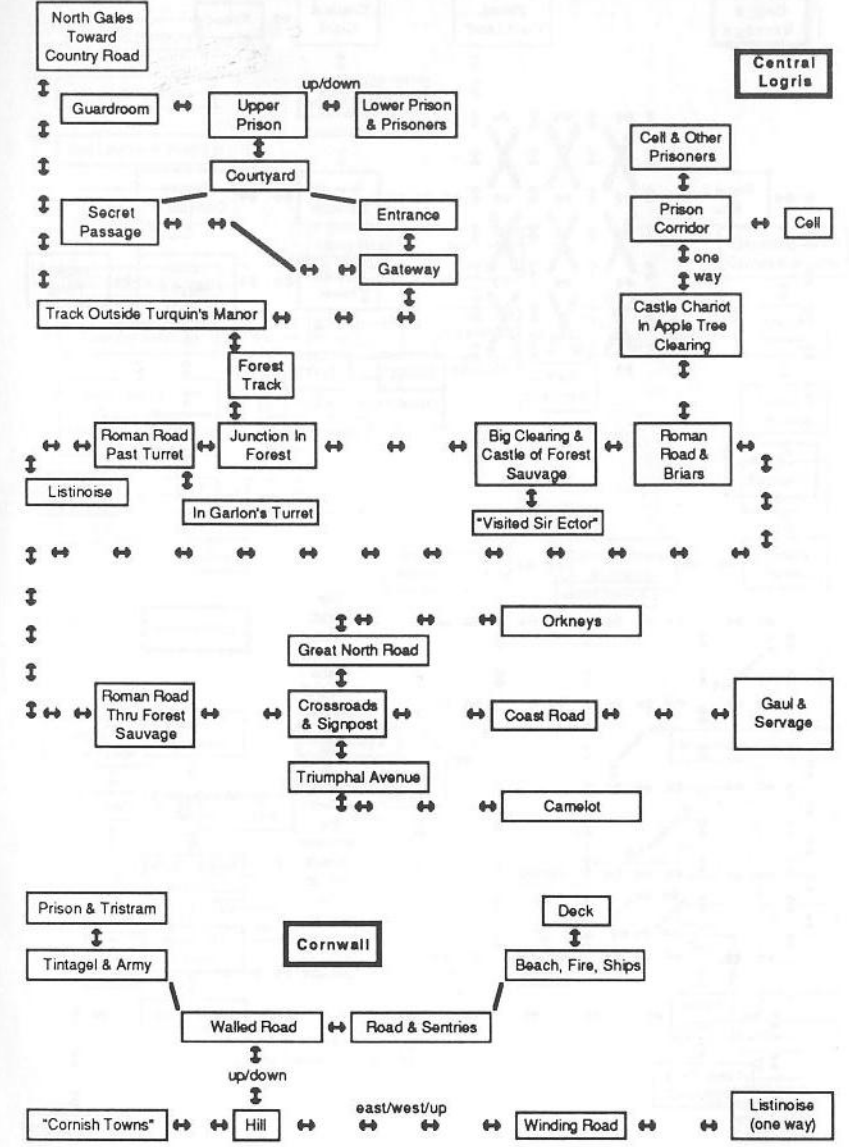

GAUL & SERVAE/LISTINOISE MAPS

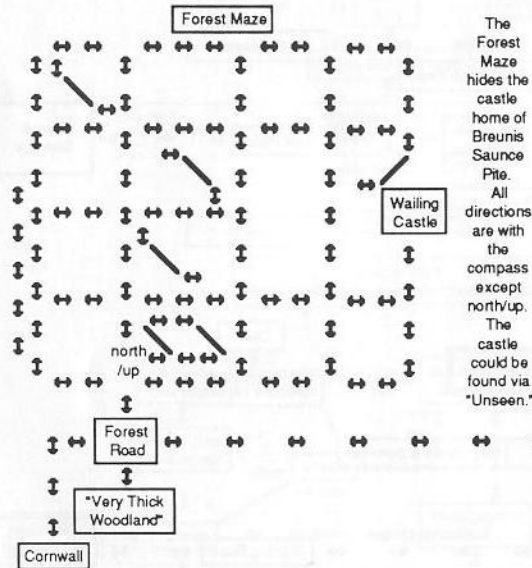
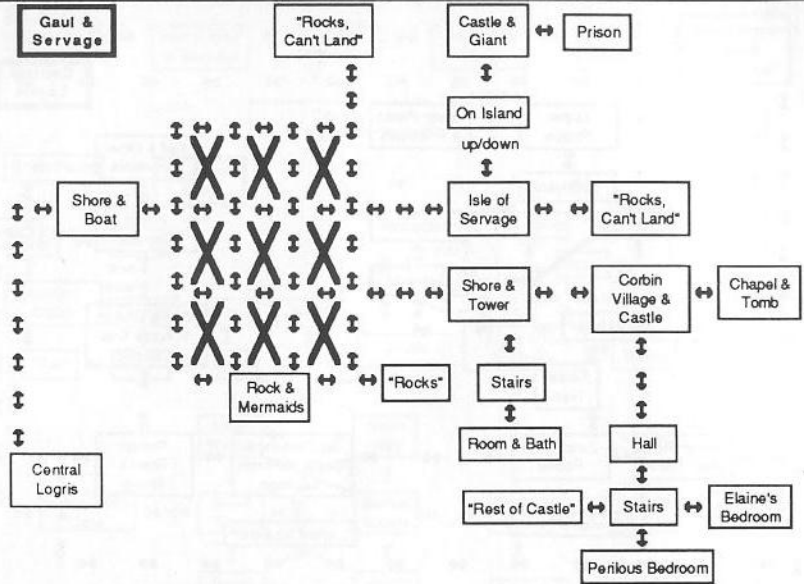

NORTHGALES/ORKNEYS MAPS

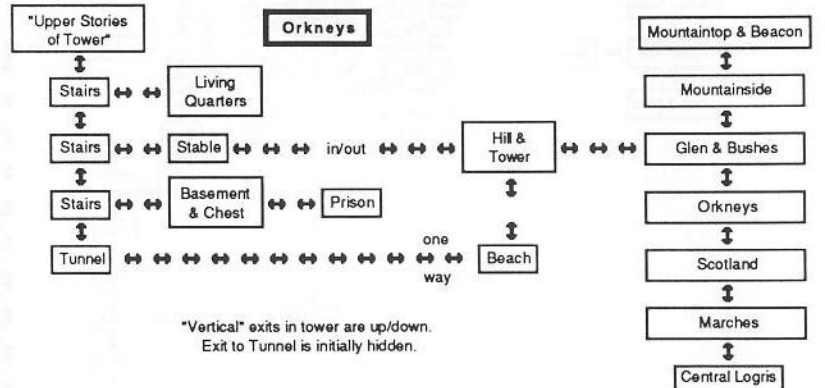
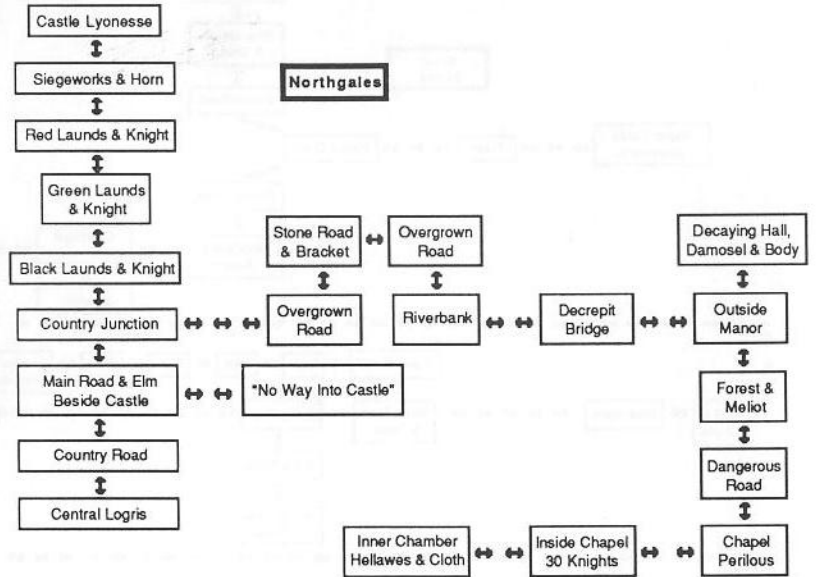

Vertical exits in tower are up/down. Exit to Tunnel is initially hidden.

GRAIL LANDS

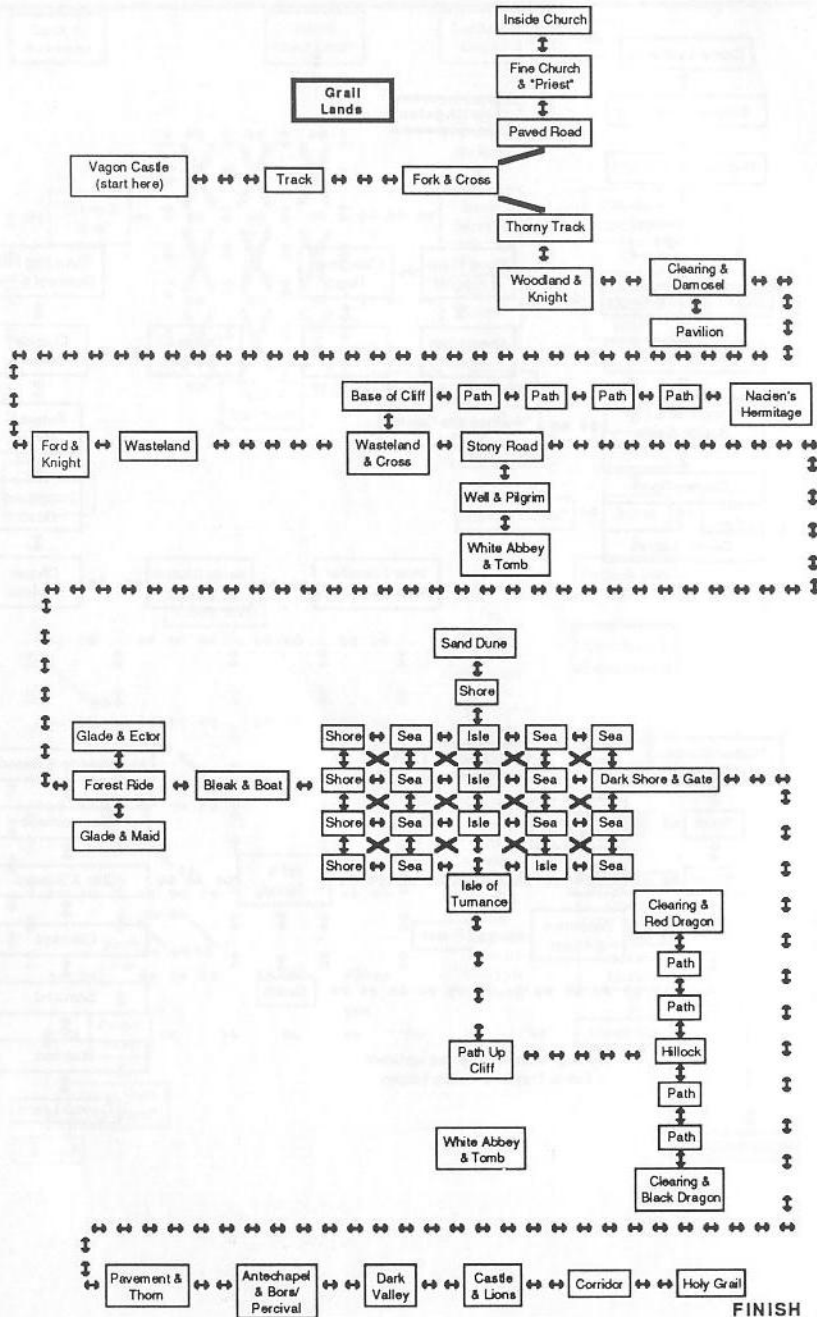

Datasoft[®]

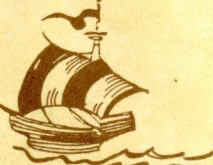
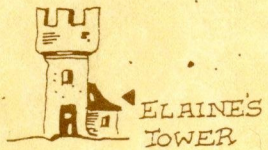
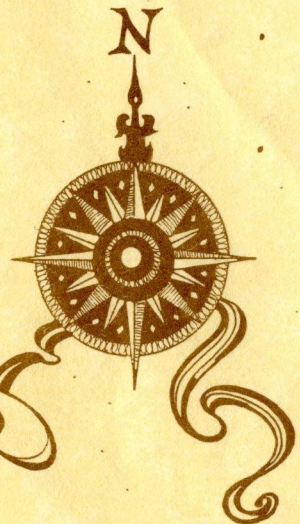

TO THE ORNYEYS

CHAPEL PERILOUS

LYONESSE

NORTHGALES

ELM

TURQUIN'S MANOR

CAMELOT

LISTINOISE

TINTAGEL

PELLAM'S TOWER

FOREST SAUVAGE

LOGRIS

CORBIN

ELAINE'S TOWER



MANDARIN SOFTWARE Level 9

Join the nationwide quest to find the Holy Grail – worth £5,000!



ere's an exciting opportunity to win the fabulous Grail pictured on the front cover of the Lancelot box. Encrusted with semi-precious stones – amethysts, garnets and opals – the 7in high solid sterling silver goblet has been hand crafted by one of the UK's most talented silversmiths and has an estimated market value of £5,000.

The goblet stands on an oak block with a solid silver plaque engraved with the winner's name, and fits in a carefully-lined presentation box. It will certainly be a prize to treasure.

The goblet has been carefully buried at a secret location somewhere in Britain. You must use your skill and ingenuity to find the exact location by solving the puzzles which Level 9 has cleverly devised.

To give everyone a fair chance, the Grail Quest has two stages:



How the contest works

The four preliminary contests all work along the same lines.

The telephone starting clues tell you which of the many clue words (in capital letters) contained within the Lancelot game to pick for each current contest.

You must find them and sort them into a master riddle which describes and spells out a place connected with Arthurian legend.

All the clue words for this example are hidden in part one of the game – in and around Merlin's house.

The starting clue given by ringing the special phone number would be as follows:

Welcome to the Grail Hotline. The clue for October 17 to November 7 is a weighty matter.

This means that all the clue words (shown in capitals) can be found in the same sentence as something to do with weight e.g. pound, ounce, ton. You have to sort them, adding punctuation, until they make sense and successfully produce a master riddle i.e. MERLIN'S GIANT MICRO UPON THE HEATH; THE WELL KNOWN STANDING CIRCLE. The answer is STONEHENGE which is reputed to have been an astronomical computer built by Merlin. You can check whether you are right because all correct master riddles spell out their own answer. Just take a look at the last letter of each word. Spotted it?

Note: This is only an example and does not form part of the contest.

Stage One

Four preliminary contests, each of which reveals a possible place (but not THE place) for the Grail. The senders of the first nine correct answers, drawn from the sack each time, will receive a scroll recording their achievement and will go forward to the final.

Stage Two

In February, all 36 finalists will simultaneously receive a further set of clues. If you are the first to telephone the correct answer you will be taken to the secret burial site to dig up the solid silver Grail, which will be yours to keep.

Stage One Preliminary Contests

The preliminary contests will run from October 1988 to January 1989. Dates are:

- From 9am October 17 to November 7
- From 9am November 8 to December 6
- From 9am December 7 to January 4
- From 9am January 5 to February 2

To take part, phone the special Grail Hotline on 0625 879914 between these dates and you will learn the current starting clue. This is the key to the individual clues within the game.

How to enter

When you have solved one of the contests, write to: *Grail Quest, Mandarin Software, Europa House, Adlington Park, Adlington, Macclesfield SK10 4NP.* Enclose the answer, the current coupon and your name, address and both daytime and evening telephone numbers.

Winners will be picked one week after each contest, from letters postmarked on or before the closing date. We regret that it will not be possible to give individual replies to other entrants.

Rules

- The competition is not open to the staff of the Europress Group and Level 9 or their relatives.
- Multiple entries are permissible only if accompanied by the correct token.
- The competition will be judged by Mandarin Software. Its decision is final, and no correspondence may be entered into.
- Please enclose a stamped addressed envelope if you would like a list of all the winners and a complete solution once the competition has been solved.



Token 1
Clue revealed:
October 17
Closing date:
November 7



Token 2
Clue revealed:
November 8
Closing date:
December 6



Token 3
Clue revealed:
December 7
Closing date:
January 4



Token 4
Clue revealed:
January 5
Closing date:
February 2



Send this token for a clue sheet to the adventure game, enclosing a stamped, addressed envelope.

