

Chapter 1

FLIGHT PREPARATIONS

Air combat is the excitement fighter pilots live for. But behind every white-knuckle second in the cockpit are hours of careful preparation.

Choose Activity Screen

The Choose Activity Screen acts as a “main menu” for the rest of the game. Each of the options on the Choose Activity Screen are discussed below.

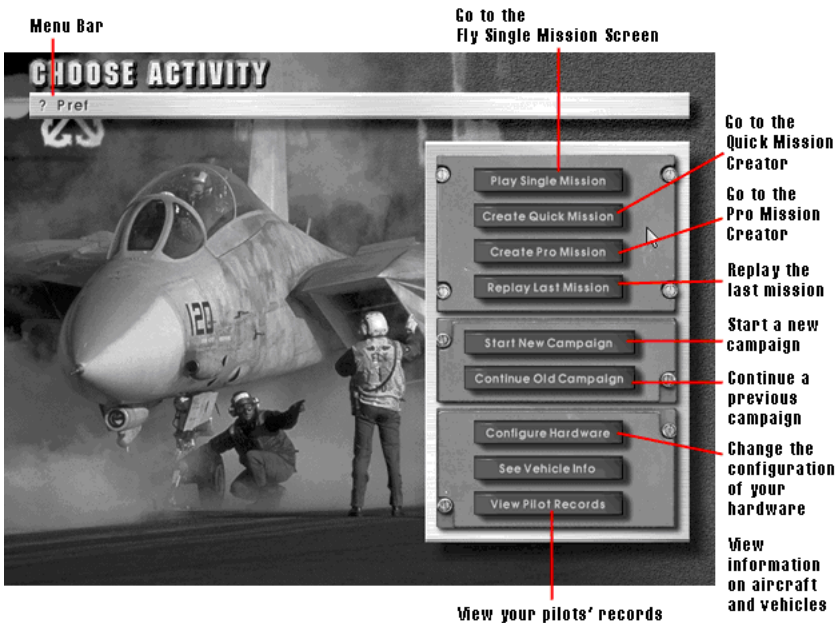

Choose Activity Menu Bar

The Choose Activity Menu Bar gives you access to the Graphics Prefs and Sound/Music Prefs control panels. Options on these control panels are described in the Install Guide.

Selecting Onscreen Options

You can select items on the screen using your mouse. Simply point at the option you want to select and click the left mouse button. Many of the flight preparation screens share features such as buttons and switches. These are described below.

Menu Bar

All flight preparation screens have pull-down Menu Bars along the top edge of the screen. To access a Menu Bar options, move the mouse cursor to a menu and hold down the left mouse button. When the options appear, drag the highlighted bar down to the option you want and release the mouse button.





Buttons

Buttons are another method for choosing options.



Those buttons identified by a blue hash mark allow you to confirm a choice and proceed to the next screen. The keyboard equivalent for these buttons is **Enter**.

Green buttons with the word “Cancel” on them allow you to return to the previous screen or the Choose Activity Screen. The keyboard equivalent for these buttons is **Esc**.

Text Buttons

Text buttons provide multiple options within the given context. Clicking on a text button cycles through different options. The left mouse button goes forward through the options; the right mouse button goes in reverse.

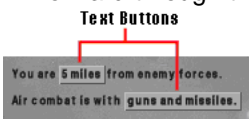

Switches and Dials

Switches and dials perform multiple functions depending upon what part of the switch or dial you click on. Text written next to switches and dials indicate what each particular position does.

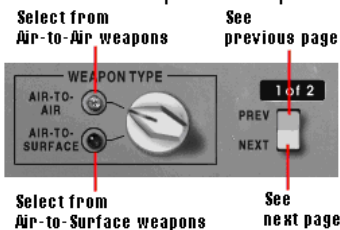

Objects You Can Drag

Objects you can drag — such as map objects and weapons — can be moved from one part of the screen to another. Click on the desired object select it, and then use the mouse to drag it to the desired position.

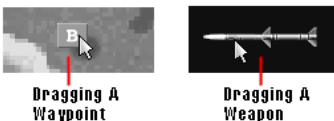

The ? Menu

The ? Menu is available on every menu bar in the game. In the preparation screens, the ? Menu contains a single option, **Quit to DOS (Ctrl-C)**. In the cockpit, the ? Menu contains an additional **End Mission (Ctrl-Q)** option.

Play Single Mission

The Play Single Mission option allows you to undertake a single, unique mission — either one of the many provided with the game, or one that you or a friend has custom-designed using the Pro Mission Creator.

To play a single mission:

1. From the Choose Activity Screen, select **Play Single Mission**. The Fly Single Mission Screen appears.

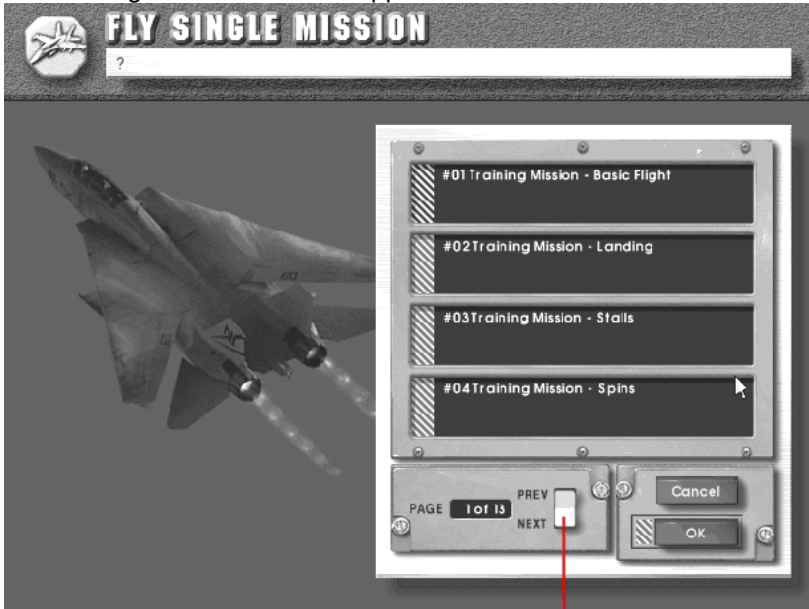

Page switch

2. Clicking on the Page Switch allows you to view the available single missions. When you see a mission you want to fly, click on the Mission Box to move the yellow highlight to that mission.

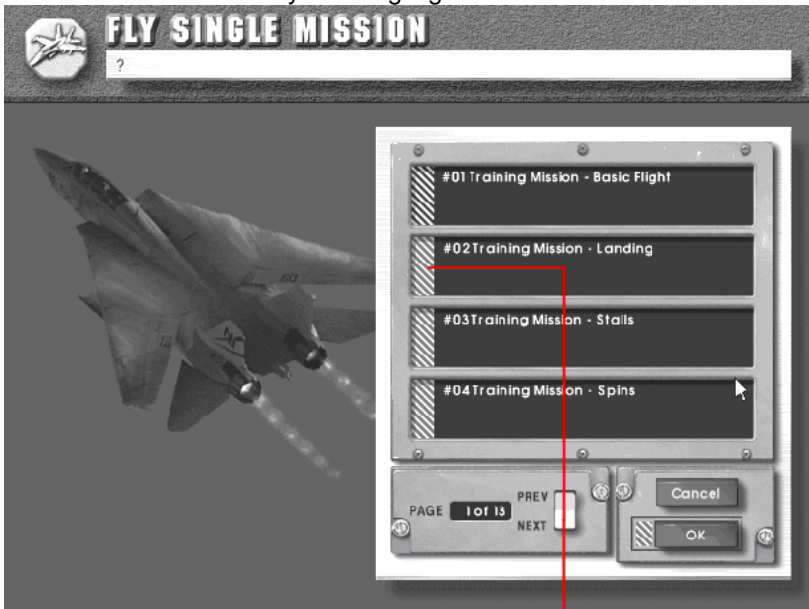

Click on Mission Box

3. Click on the **Ok** button or press **Enter** to select the mission. Depending

on how the mission was set up, you may see one or more of the following screens: Mission Brief, Mission Map, Aircraft Selection, or Load Ordnance. Each of these screens is covered in this chapter under [Start New Campaign](#).

Create Quick Mission

The Quick Mission Creator allows you to set up an air combat engagement quickly and painlessly. You specify general design parameters and the Quick Mission Creator delegates most design tasks to the computer. Quick Missions, therefore, retain the element of surprise, making excellent training missions.

To create a Quick Mission:

1. From the Choose Activity Screen, select **Create Quick Mission**. The Quick Mission Creator appears.



2. Click on the text boxes to bring up selection panels that let you change various mission parameters for both friendly and hostile forces. These parameters are explained below.

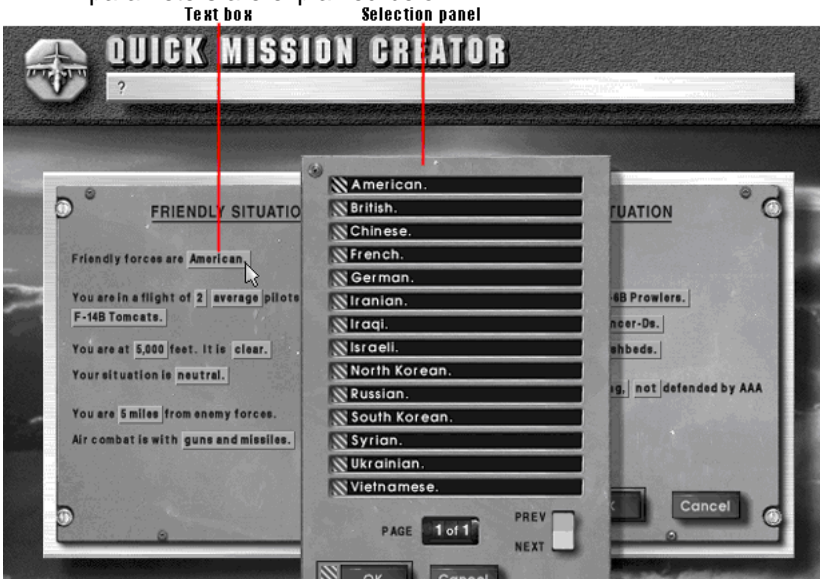

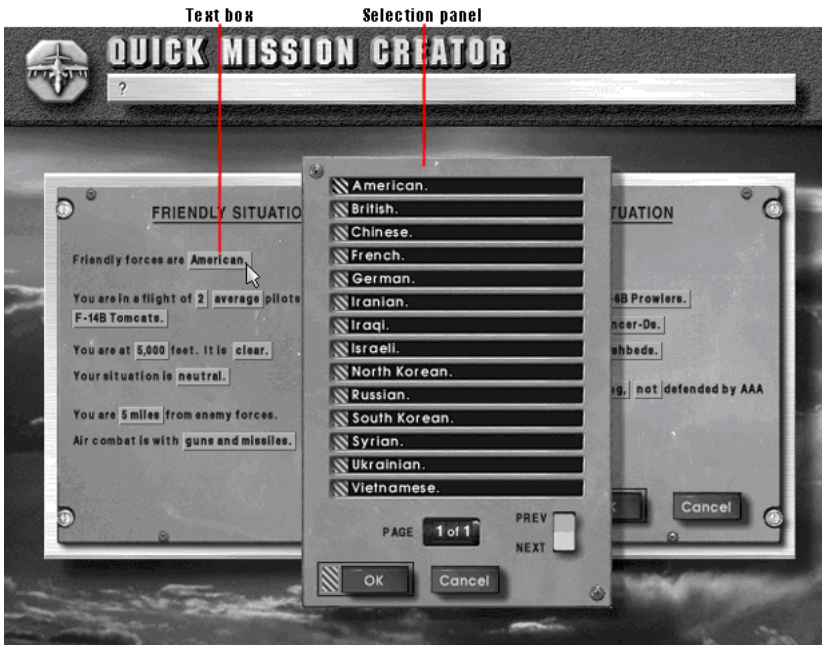

- When you have set the mission parameters to your liking, click on the **OK** button or press Enter. You will be placed in the lead aircraft of the friendly group. All aircraft carry default weapon loads.

Setting Up Quick Missions

The Quick Mission Creator allows up to three friendly aircraft, three enemy flights, and one option ground target in a single mission. How these units begin the scenario and fight is determined by the parameters you specify.

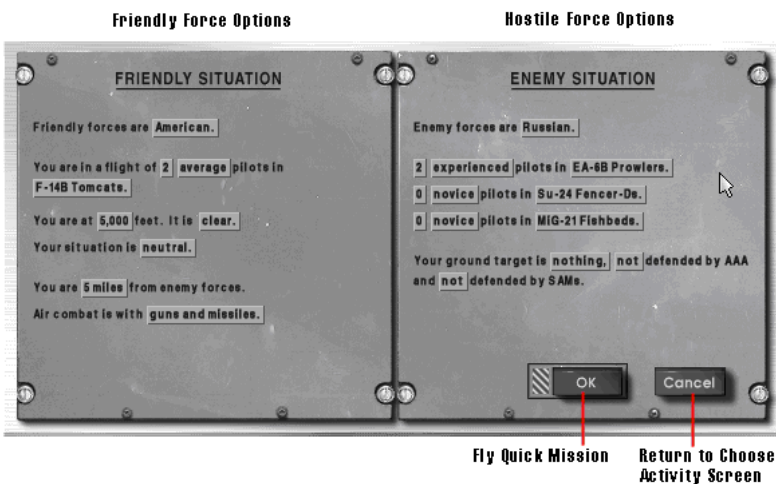

Friendly Forces

As the name implies, friendly forces fly and fight with you. By clicking on the text buttons you may alter:

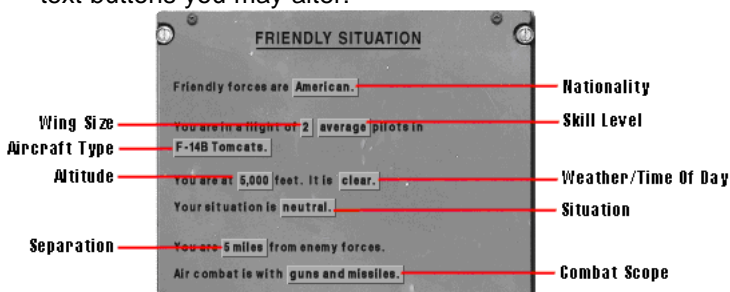

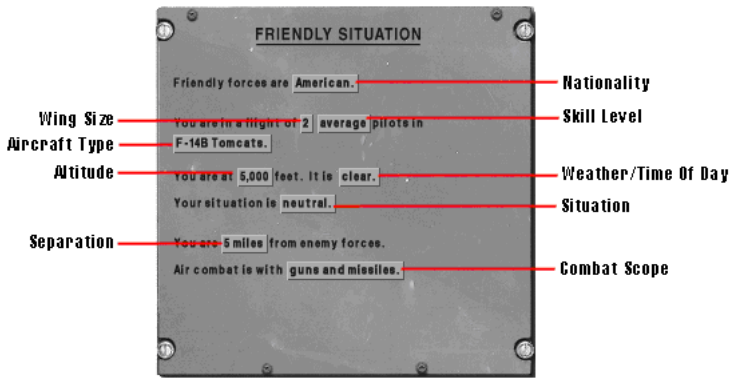

Nationality	Select the nationality for which you will fly. Choosing a nationality does not limit your choices of aircraft.
Wing Size	Specify the number of pilots (including yourself) in your group, up to a maximum of three.
Skill Level	Select Ace, Experienced, Average, or Novice skill level for your wingmen.
Aircraft Type	Choose the type of aircraft your forces will fly during this mission. All friendly aircraft will fly this same aircraft type. You may only choose one of the six aircraft available to players: the F-14, F/A-18, F-22, F-104, A-7, or Su-33.
Altitude	Specify the starting altitude of the group: from 5,000 to 40,000 feet.
Weather/Time of Day	Set the weather or time of day: Dawn, Clear, Cloudy, Overcast, Foggy, Sunset, or Night.
Situation	Specify the situation your friendly forces are in. Friendly forces can hold the Advantage, be in a Neutral situation, or be at a Disadvantage.
Separation	Set the initial separation between friendly and hostile forces: from 1 to 50 nm.
Combat Scope	Select which weapons will be used: Guns Only or Guns and Missiles. Note that guns only means no air-to-air missiles. Air-to-air ground missiles are still allowed so you can attack a ground target if you've specified one.

Hostile Forces

For hostile forces, you may alter the following:

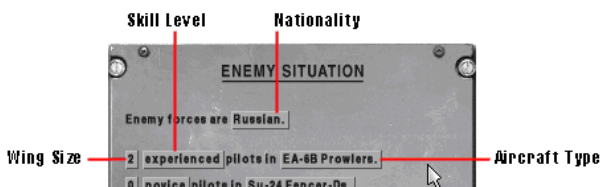

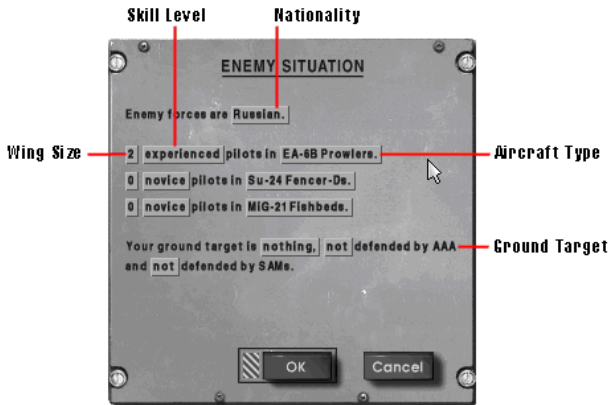

Nationality Specify which country enemy forces come from. This is merely for designation purposes and does not limit enemy aircraft to any certain nationality.

Wing Size You may add up to three enemy groups, each with up to 5 aircraft. Select 0 to disable a particular group.

Skill Level Choose from Ace, Experienced, Average, or Novice for the specified group. Select Ace, Experienced, Average, or Novice skill level for your wingmen. As with the friendly forces, the skill level indicates the *range* of skill levels in the given group. The exact skill level per pilot is chosen randomly by the Quick Mission Generator.

Aircraft Type Choose the type of aircraft used by the specified group.

Ground Target You may select a ground target for your forces. Additionally, you can determine how heavily SAMs and AAA defend the target.

Create Pro Mission

The Pro Mission Creator allows you to set up complex missions involving multiple wings, multiple ground targets, air defenses — even a campaign of your own.





The Pro Mission Creator is a complex tool requiring a detailed explanation. See [Chapter 7: Creating Custom Missions](#).

Replay Last Mission

The Replay Last Mission option allows you to do just that: repeat the last played mission. This option assumes that you haven't quit out of *U.S. Navy Fighters* since your last mission.

Start New Campaign

Campaign Mode is the heart of *U.S. Navy Fighters*. All of your training has prepared you for this moment. Trouble brews in the distant parts of the world, and you've been called upon to protect U.S. interests.

Select Campaign Screen

From the Choose Activity Screen, select **Start New Campaign**. The Select Campaign Screen appears.



Return to Choose Activity Screen Go to Select Pilot Screen



The original U.S. Navy Fighters comes with one 50 mission campaign: Ukraine 1997. Since this option is already highlighted, clicthe **OK** button or press **Enter**.

Select Pilot Screen

The Select Pilot Screen does more than let you choose your alter-ego in the campaign. A pilot is in essence a saved game. Creating a new pilot is equivalent to starting a new campaign. Likewise, choosing a pre-existing pilot is equivalent to continuing his campaign.

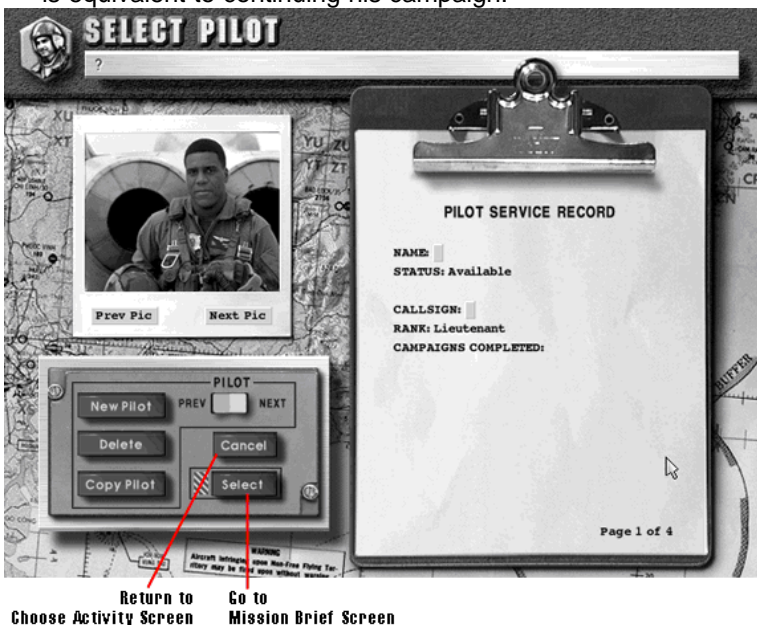

Use the **Page Up** and **Page Down** keys to flip through the clipboard pages, which allow you to alter your aircraft's nose and tail art as well as view any campaign medals you may have earned.

Click on any of the following onscreen options to alter a pilot file:

Pilot Switch	You can create multiple pilots, each active in a separate campaign. Use this switch to select the desired pilot.
New Pilot	Create an entirely new pilot. The pilot begins with the rank of Lieutenant and no awards or commendations.
Delete Pilot	Delete the currently selected pilot.
Copy Pilot	Create a backup copy of your pilot. If your pilot is killed or captured, you may resume his career from the last backup.
Name	Specify your pilot's full name.
Callsign	Specify your pilot's callsign.
Squadron	Choose your pilot's squadron. Squadron choice determines what emblems are displayed on your aircraft.
Prev Pic	View the previous picture. You choose the face of your pilot.
Next Pic	View the next picture.
Nose Art	You may add customized artwork to the nose of your aircraft.
Tail Art	You may add customized artwork to the tail of your aircraft.

When you've created the pilot you want, click the **Select** button or press **Enter**.

Video Briefings

You typically fly two missions a day. At the beginning of each day you receive a short briefing from the intelligence officer. Before each mission you receive an additional mission briefing from your CO. You can skip any individual briefing by pressing **spacebar**. If you want to skip all of the briefings before any given mission, press **Esc**.

Mission Brief Screen

The Mission Brief Screen allows you to read the background and objectives of each mission in the campaign.

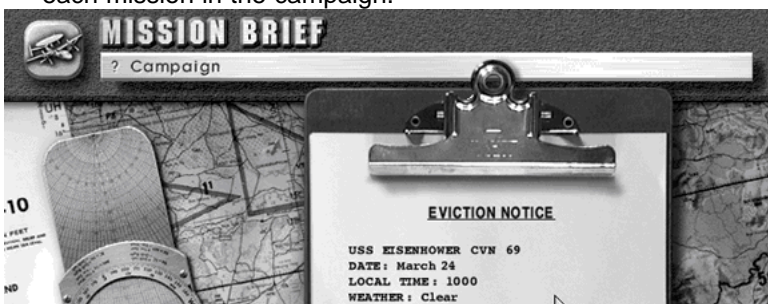



Page Switch

Go to Mission Map Screen

Return to Choose Activity Screen Mission Brief Menu Bar

Click on the Page switch or use the **Page Up** and **Page Down** keys to flip through the clipboard pages. Once you feel like you've got a handle on the situation, click on the **OK** button or press **Enter**.

Mission Brief Menu Bar

Campaign Menu

Option	Description
Replay This Mission	Go back to the beginning of the mission so you can view the videos again.
Exit Campaign	Return to the Choose Activity Screen.

Mission Map Screen

The Mission Map Screen lets you plan your waypoints according to the mission

objectives.





Editing Waypoints

You can edit waypoints in the mission for your wing only. Your superiors designate the waypoints for other aircraft in the mission — these *cannot* be altered.

Click on a waypoint to select it.



Waypoint settings appear in the Object Details panel. Click on the text buttons to change the following settings:

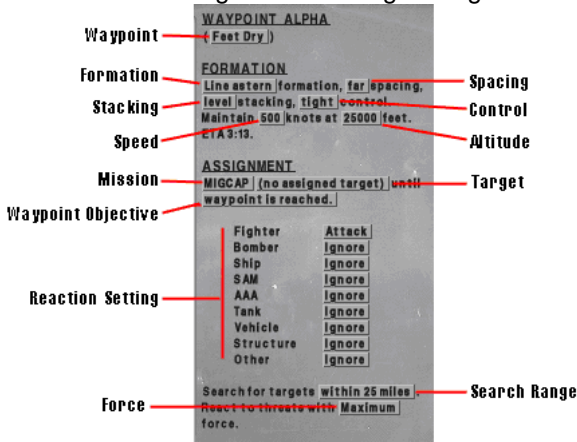

Setting

Options Description

Waypoint		Brings up a selection panel that lets you name the waypoint (Ingress, Merge, Strike, Feet Wet, etc.)
Formation	Echelon, Line abreast, Line astern	See Waypoint Formation for wing formations, spacing, and stacking.
Spacing	Far, Near	See Waypoint Formation for wing formations, spacing, and stacking.
Stacking	High, Level, Low	See Waypoint Formation for wing formations, spacing, and stacking.
Control	Tight, Loose, Medium	See Wingman Commands for control setting descriptions
Speed	0 - 3,000 kts	How fast your wing should travel to the waypoint. Note that setting a speed (for example, 3,000 kts) does not guarantee that your particular airplane is capable of that speed at the given altitude.
Altitude	0 - 80,000 ft	The altitude at which your wing should travel to the waypoint. Note that setting an altitude (for example, 80,000 ft) does not guarantee that your airplane is capable of attaining that altitude.
Mission	Normal Flight MIGCAP BARCAP Wild Weasel CAS Anti-Ship Hi/Lo Sweep	See Saving Custom Missions7_1_9 for Objective descriptions.
Target	Variable	The enemy target you're meant to destroy or the friendly object you're supposed to protect. Click on the text button, and then click on the enemy target or friendly object. If no specific target is assigned, no assigned target appears here.

Reactions	Attack, Defend, Ignore, Evade	The reaction of aircraft in your wing to various types of enemy objects. These represent your wingmen's default orders only — any orders you give them during the mission replace these orders.
Search Range	Various	The range within which your wingmen will search for enemies. Note that your wingmen are still limited by the type of detection they are using.
Force	Equal, Double, Maximum	No effect on your wing.

Mission Map Menu Bar

The Mission Map Menu Bar gives you control over waypoints and your view of the map.

View Menu

Option	Key Equivalent	Description
Scroll left	cursor left	Scroll map view left.
Scroll right	cursor right	Scroll map view right.
Scroll up	cursor up	Scroll map view up.
Scroll down	cursor down	Scroll map view down.
Center map at cursor	N	Center the map display on the current cursor position.
Center map at selection	B	Center the map display on the currently selected object.
Zoom in	plus (+)	Zoom in on map.
Zoom out	minus (-)	Zoom out on map.
Smart zoom		When activated, you zoom in and out on the currently selected object. If no object has been selected, you zoom in and out on the center of the map.

Waypoint Menu

Option	Key Equivalent	Description
Add	A	Add a waypoint for a selected aircraft, wing, ship, or vehicle. The object must be selected before you can assign it a waypoint.
Delete	D	Delete a waypoint for a selected aircraft, wing, ship, or vehicle. The waypoint must be selected before you can delete it.
Create loop	C	Create a loop between two waypoints. Select the beginning waypoint, select Create loop, and then click on the end waypoint. The aircraft will travel from the initial waypoint, along any intermediary waypoints, until it reaches the end waypoint. It will repeat this process indefinitely.
Delete loop	E	Deletes a loop between two waypoints. Select the end waypoint, and then select Delete loop.
Select prev waypoint	[Select the previous waypoint for the selected object.
Select next waypoint]	Select the next waypoint for the selected object.

Show Menu

Planes, SAM sites, etc.

The Show Menu controls what classes of objects are currently displayed on the map. Complex missions may require “decluttering” the screen by disabling some frequently-appearing units, such as AAA and SAM sites. This menu allows you to hide classes of objects while viewing a mission.

When a checmardisappears next to an object class, objects from that class are displayed on the map. To hide a class, select it from the menu; the checmardisappears and objects from that class are no longer shown on the map. The units still exist in their proper

positions, they're simply not displayed.

Mission Map Menu Bar

Campaign Menu

Option	Description
Replay This Mission	Go back to the beginning of the mission to view briefings again.
Exit Campaign	Return to the Choose Activity Screen.

Aircraft Selection Screen

The Aircraft Selection Screen shows all of the aircraft available to you for the rest of the campaign. This is where you decide which aircraft you'll take up on the mission.



There are a few considerations involved in selecting an airplane. Suitability to the mission is your primary consideration. Here knowledge of the aircraft available to you is invaluable. For example, it wouldn't be wise to undertake a strike mission in a F-14B, which lacks strike capabilities. Likewise, don't rely on the A-7E to be a good interceptor — it lacks speed and maneuverability. Choose the right airplane for the right job.

Your second consideration is damage. It's almost inevitable that your aircraft will take damage in some missions. Damaged airplanes must be repaired, and the man-hours of mechanic's time available to you are limited. For details on repairing aircraft see [Repairing Aircraft](#).

Click on the airplane you want to fly on the mission, and then click on the **Arm Plane** button or press **Enter**.

Aircraft Selection Menu Bar

Cheat Menu

Option	Description
Allow Flying Any Plane	Allow unlimited airplanes for the campaign, including the F-22, which normally doesn't appear until Mission 40. As a bonus, you can also fly the F-104, which would not appear on a carrier in real life.

Campaign Menu

Option	Description
Replay This Mission	Go back to the beginning of the mission so you can hear the videos again.
Exit Campaign	Return to the Choose Activity Screen.

Load Ordnance Screen

The Load Ordnance Screen allows you to designate the number and types of weapons your aircraft will carry in the mission. Your airplane's hardpoints appear on the right, while available weapons appear on the left.

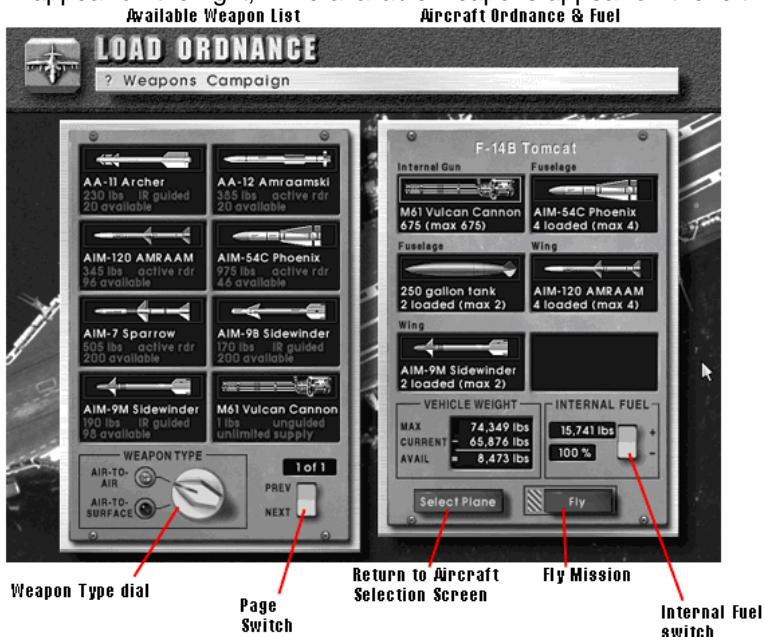

Loading & Unloading Weapons

Use your mouse to choose weapon types (Air-to-Air or Air-to-Surface) by

clicking on the red lights next to the Weapon Type dial.

To load weapons or extra fuel tanks onto hardpoints, move the mouse cursor over a weapon, hold down the mouse button, and drag the weapon to the hardpoint.

Click and drag Weapons to load and unload

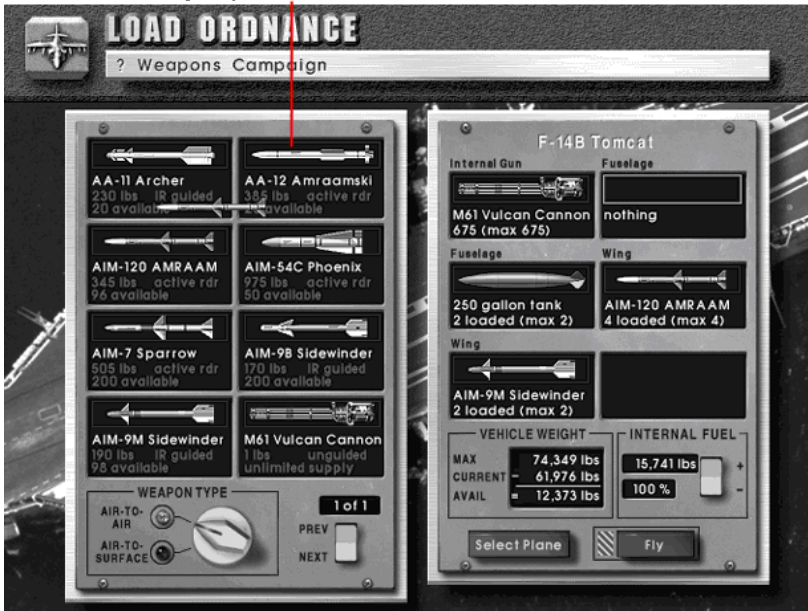

To unload specific weapons from your hardpoints, move the mouse cursor over a weapon, hold down the mouse button, and drag the weapon back over to the weapon list. You can also select **Unload All** from the Weapons Menu to clear all ordnance from your aircraft.

Weapon loads on aircraft must be balanced — that is, the weight distribution on the wings and fuselage must be equal. Your weapon load is automatically balanced for you as you choose weapons.

If you need to adjust the fully loaded weight of your airplane, you can left-click on hardpoints to increase weapons or right-click to decrease weapons. Once you've loaded the ordnance you want on the mission, click on the **Fly** button or press **Enter**.

Loading & Unloading Gun Rounds

To unload gun rounds, click the right mouse button on the gun icon. To reload gun rounds, click the left mouse button on the gun icon.

Click on the gun icon to load & unload rounds

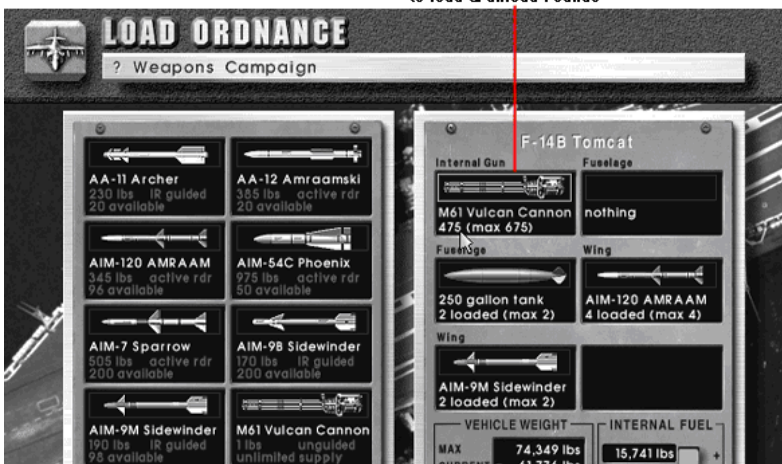

Click on the gun icon
to load & unload rounds

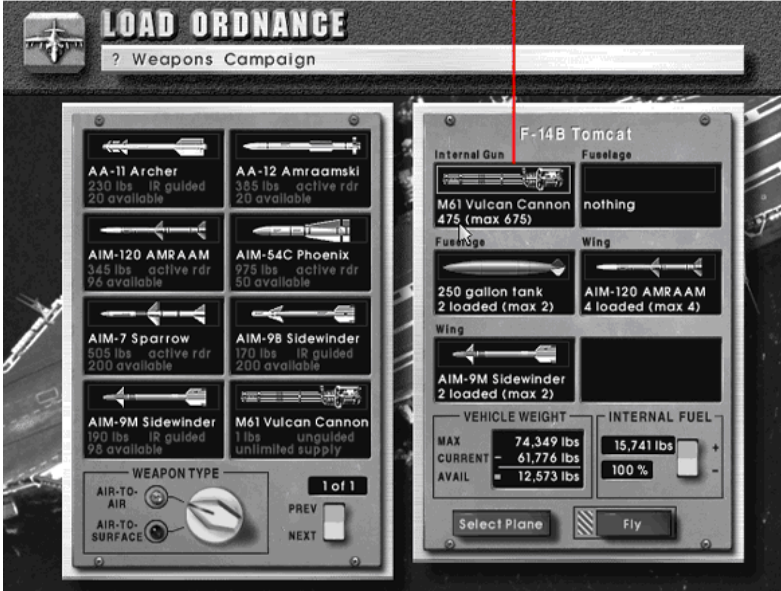

Adding & Removing Fuel

The current takeoff weight (in the Vehicle Weight box) is the combined weight of your airplane, weapons, and fuel. You may need to reduce your internal fuel to accommodate more weapons or, eliminate weapons to increase your fuel for long-range missions. For example, the Su-33 has a massive internal fuel tank, giving it exceptional range; however, at 100% fuel it can barely carry a few missiles. To remove fuel from your internal fuel tank, move the mouse cursor to the Internal Fuel Switch and left-click on the minus (-) end. To add fuel, left-click on the plus (+) end of the switch.



Left-click on the switch
to add or remove fuel

Note that you must keep your weight *under* the maximum takeoff weight or you won't be able to fly.

Load Ordnance Menu Bar

Weapons Menu

Option	Description
Unload All	Unload all weapons from your aircraft. Your internal gun remains fixed, though it now carries no rounds. Your internal fuel supply remains unchanged.
Cheat (load anything anywhere)	Gives you unlimited vehicle weight, allowing you to load as many weapons as you like onto your hardpoints. Note that the number of hardpoint <i>stations</i> remains the same, thus limiting how many <i>kinds</i> of weapons you can take.

Campaign Menu

Option	Description
Replay This Mission	Go back to the beginning of the mission so you can hear the videos again.
Exit Campaign	Return to the Choose Activity Screen.

Ending the Mission

You can end a mission by selecting **End Mission (Ctrl-Q)** from the ? Menu or by exiting to DOS (**Ctrl-C**).

In order for the mission to end successfully, you must achieve *all* of your mission objectives and get within 8 nm of the carrier. A radio message — “We’re almost home!” — lets you know when you’re in the carrier’s protective zone.

If you don’t achieve your mission objectives but make it back to the carrier, you fail your mission. If you end the mission *before* you make it back to the carrier’s protective zone, you fail the mission and lose an airplane.

Ejecting is another way to end the mission, and it’s a risky one at that. Whenever you bail out, you lose that airplane from your inventory. If you’re over enemy territory, you also run a risk of being captured by enemy forces. This ends the campaign immediately. If you’re rescued, you continue the campaign minus the aircraft you lost.

Repairing Aircraft

After each mission, the Aircraft Repair Screen appears. This screen allows you to make repairs to the limited number of airplanes available to you in Campaign Mode.

Anytime an aircraft is hit by enemy weapons, it takes damage. Aircraft require a high degree of maintainance — even the stress of normal flight will result in a small fraction of miscellaneous damage to your airplane.

Damage is measured in terms of percentages. At 100% damage, your airplane is guaranteed the loss of one or more critical systems: oil lines, fuel tank, radar, weapons, control surfaces, etc. Your airplane can take damage beyond 100%, but it won't be capable of flying again until its damage is repaired to under 100%.

You are allotted 50 man-hours of repair after each mission. You don't necessarily have to repair the airplane you just flew — you can choose to spend these hours on any damaged aircraft on the deck. Note, however, that hours are not cumulative; that is, you cannot save them from mission to mission. If possible, spend all of the hours available repairing aircraft, because they won't be available to you on the next mission.

If an aircraft takes damage, you'll notice yellow mules surrounding it. The more mules, the more damage the aircraft has taken. You can view the exact amount of damage on any of your airplanes simply by pointing the mouse cursor at the airplane and clicking.

To repair the damage to an airplane, click on the damage line in the selection panel. The man-hours needed to repair it are automatically subtracted from your total.

Death, MIA, Reassignment

There are several ways for the campaign to end permanently. Your pilot can die. He can bail out and get captured by the enemy. Or he can fail more than five missions and get reassigned to some other part of the world.

In all of these unfortunate events, there is a way to turn back the hands of time and give your hero another chance. After flying the losing mission, a dialog panel will appear asking you if you want to try this mission again. If you select **No**, your pilot is gone forever and that campaign is over. If you select **Yes**, wait for the mission brief screen to appear. If you don't want to replay the mission now, select **Exit Campaign** from the ? Menu. If you don't actually want to replay the mission, just wait for the Mission Brief Screen to appear and select **Exit Campaign** from the ? Menu.

Winning The Campaign

A campaign consists of a series of missions which must be executed in order. As in real life, your primary goal is survival. You must survive all of the sorties in your tour in order to win. This means that you don't have to repeat individual missions until you succeed at each one. If you fail a particular mission, it's assumed that other pilots step in and achieve your mission objective for you.

Keep in mind that the Brass doesn't like to re-deploy assets to cover your failures. While your superiors understand the formidable challenges you face, they expect maximum performance from you. If you fail more than four missions, you will be assigned a different task far away from the carrier. The war will be over for you.

Resource Management

You begin the campaign with a limited number of aircraft of fighter aircraft.

What you see on the decis what you get, except that you have an unlimited number of A-7E attack aircraft. In addition to your initial aircraft, you receive one F-22 after completing Mission 39.

The goal is to complete the campaign with a limited number of aircraft and missiles. Lose all of your best aircraft in the beginning missions and you may find yourself in trouble down the line. Waste all of your expensive, high-tech missiles too soon and you may not have enough to hit critical targets later on.

Continue Old Campaign

Campaigns are saved under the names of pilots. **The Continue Old Campaign** option brings you to the Select Pilot Screen. Select the pilot associated with the saved campaign you want to play.

For more details, see [Select Pilot Screen](#) under *Start New Campaign* in this chapter.

Configure Hardware

The **Configure Hardware** option allows you to change the current game configuration. Consult the *Install Guide* for more details on configuring the game.

See Vehicle Info

The **See Vehicle Info** option lets you view all of the aircraft, ships, ground vehicles, and objects in *U.S. Navy Fighters*.

Click on the onscreen options to manipulate your view or to looat another object.

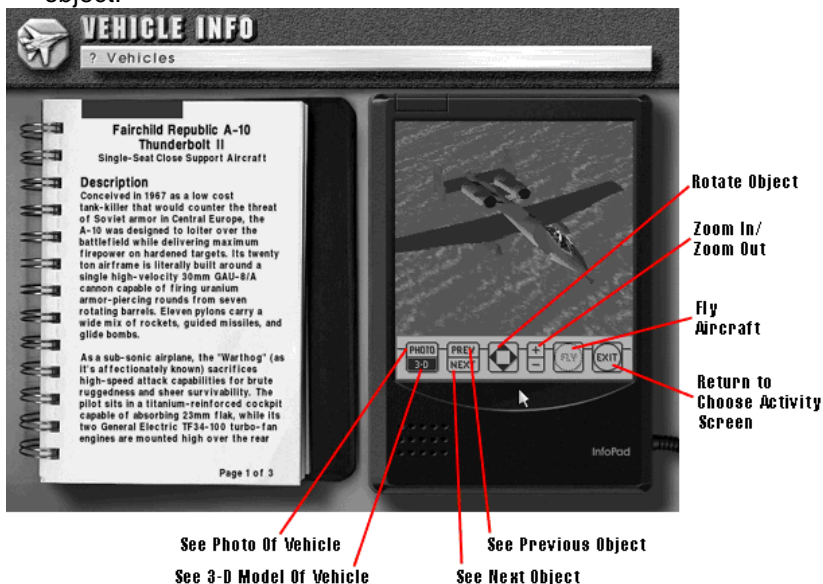

Use the **Page Up** and **Page Down** keys to flip through the text describing the object. When you are finished looking at vehicles, click on the **Exit** option or press **Esc**.

Vehicles Menu

Use the Vehicles Menu to change the class of vehicles you're viewing.

View Pilot Records

The **View Pilot Records** option lets you view all of the active and inactive pilots.



Use the **Page Up** and **Page Down** keys to flip through the clipboard pages, which allow you to view your aircraft's nose and tail art as well as any campaign medals the pilot may have earned.

Pilot Switch

Clickswitch to view your pilots.

Delete Pilot

Delete the pilot you're currently viewing.

Copy Pilot

Create a backup copy of your pilot. If your pilot is killed or captured, you may resume his career from the last backup.

When you're finished viewing your pilots, press **O** or press **Enter** to return to the Choose Activity Screen.

Chapter 2

COCKPIT FAMILIARIZATION

Cockpit Elements

While flying, your immediate environment consists of a cockpit display, the Head Up Display or HUD, and a number of instrument windows that you can activate.

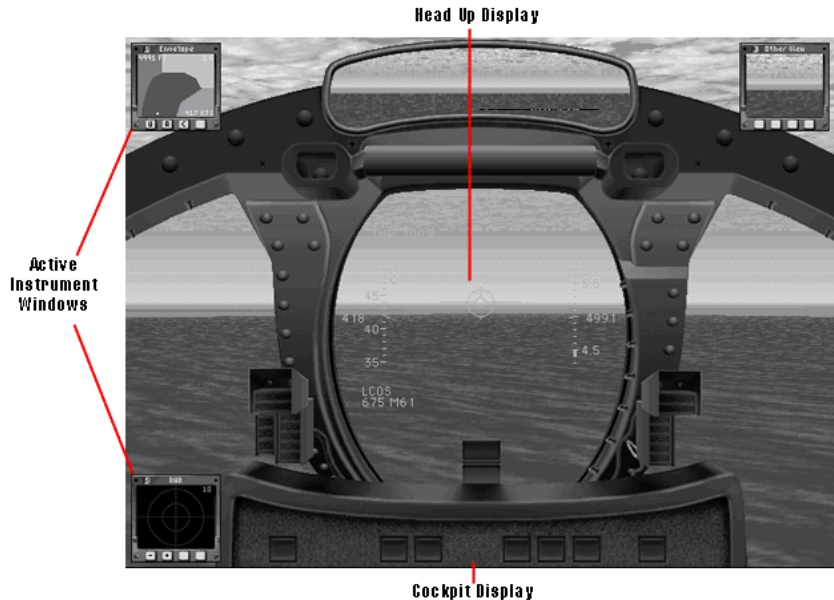

The Cockpit Display

You can display the cockpit for added realism or hide it in order to increase your view of the world outside. Press **Backspace** to turn the cockpit on or off.

The Head Up Display

The Head Up Display, or HUD, is a transparent sheet before the glareshield upon which critical information is projected. The HUD reduces the need to look at other instruments in the cockpit, thus allowing the pilot to concentrate on the combat situation.

Information Windows

Information Windows let you display important instruments, views, and information in the corners of your screen. You choose which windows are displayed, depending on the nature of the task.

HUD Flight Information

Basic flight information is displayed whenever the HUD is active. Each airplane's HUD has slightly different symbology. For example, altitude might be displayed numerically, or with a "tape," or both.

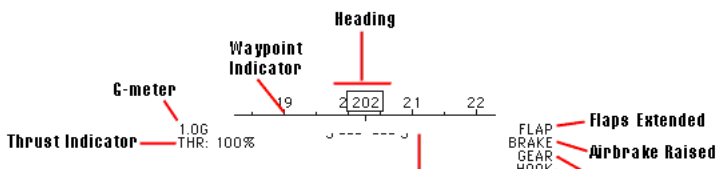

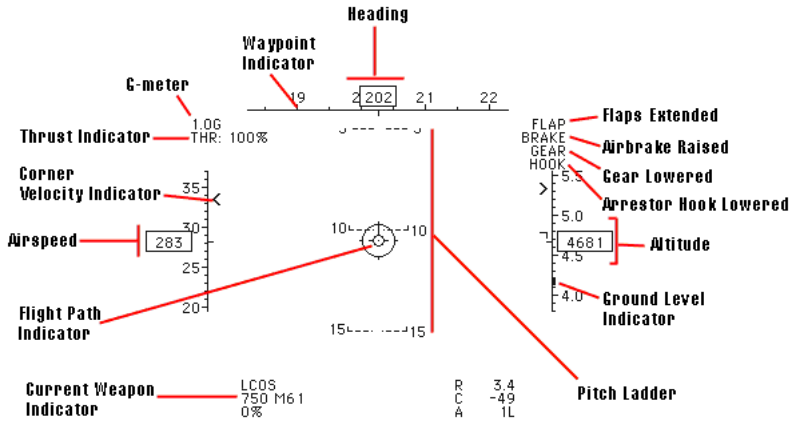

Above Ground Level Indicator

As you fly over land, ground level changes. The AGL indicates your relative proximity to the ground below your aircraft. For example, when flying over a mountain, you could be 5,000 feet above sea level but only 200 feet above the ground.

Pay particular attention to the AGL when flying in clouds or fog.

Airspeed

The airspeed tape scrolls up and down, indicating changes in airspeed. Your current airspeed is displayed numerically at the center of the tape. Indicators show your maximum and minimum (ie, stall) speeds.

In *U.S. Navy Fighters*, your airspeed indicator measures true airspeed and not indicated airspeed.

Altitude

The altitude tape scrolls up or down, indicating changes in altitude above sea level. Your current altitude is displayed numerically at the center of the tape.

When the ILS is engaged, additional marks indicate your current vertical speed (how fast you are diving or climbing) and what the maximum vertical speed allowed for landing is.

For more information on the ILS, see [HUD in Navigation Mode](#) in this chapter. For a detailed guide to using the ILS, see [Chapter 5: Carrier Qualifications](#).

Auto

Indicates that the autopilot is engaged and steering your aircraft to the current waypoint. Press **A** to turn the autopilot on/off.

Corner Velocity Indicator

The corner velocity indicator shows your corner speed at your current altitude.

If you're flying faster than corner speed, the cue will be displayed below the numeric airspeed readout. If you're flying slower than corner speed, the cue will be displayed above the numeric airspeed readout. When you fly at the indicated corner speed, you have maximum turn performance available. Above or below this speed, turn performance suffers.

For more information on corner velocity, see [Turn Performance](#) in [Chapter 3: Flight School](#).

Current Weapon Indicator

Indicates the current weapon and the number of rounds left.

Flaps, Gear, Brakes & Hook

The upper right hand corner of the HUD indicates the flap, gear, and brake status. If FLAPS, GEAR, BRAKE, or HOOK appears in the upper right corner, then the specified device is extended. If the word does not appear here, the device is retracted.

Flight Path Indicator

The Flight Path Indicator shows which direction the aircraft is actually moving, regardless of flight attitude. When Angle of Attack (AOA) is positive, the Flight Path Indicator is below the HUD's center. When the AOA is negative, the Flight Path Indicator is above the HUD's center.

For more information on Angle of Attack, see [Chapter 3: Flight School](#).

G-Meter

The G-meter shows how much G the aircraft is currently pulling. For more information on role of G-Force in maneuvering, see [Chapter 3: Flight School](#).

Heading

The heading tape is your compass. It scrolls right and left, indicating changes in your heading. Your current heading is displayed numerically at the center of the tape.

Pitch Ladder

The pitch ladder indicates the aircraft's pitch and roll relative to the horizon.

The center of the HUD always represents where the nose of your aircraft is pointing. Each pitch ladder line represents 5 degrees above or below the horizon. Positive pitch lines — indicating that the nose is pointed above the horizon — are solid. Negative pitch lines — indicating that the nose is pointed below the horizon — are represented by dashed lines. *The ends of the pitch lines always point toward the horizon.*



The pitch ladder lines also represent your aircraft's roll. Think of them as representing your wings: when the lines are horizontal, your wings are parallel to the horizon. When the lines are vertical, your wings are at a right angle to the horizon.

Thrust Indicator

The thrust indicator shows the engine's current throttle setting as a percentage of maximum engine output. AFT indicates that afterburners have been lit.

Time Compression Level

Rate of time compression appears in the upper right corner when time compression has been activated. During time compression, your stick inputs are reduced so your airplane is still controllable.

Waypoint Indicator

The waypoint indicator moves along the underside of the heading display showing the direction to the selected waypoint. When the indicator is centered under the heading readout, you are flying directly at the next waypoint.

For more information on waypoint navigation, see *The HUD in Navigation Mode* in this chapter.

The HUD In Weapons Mode

Weapons Mode provides you with targeting symbology needed to designate and engage targets.

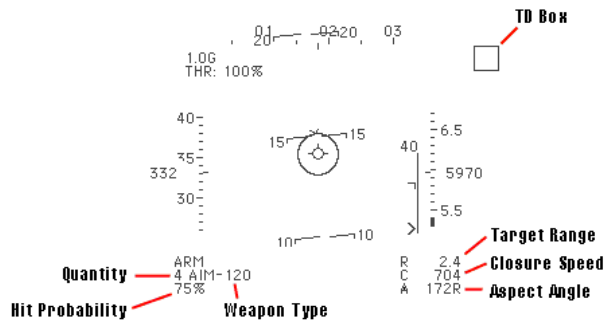

Aspect Indicator

Indicates a targeted aircraft's aspect angle in degrees. The aspect angle measures the angle between the target's nose and your airplane. When the target is at 180 degrees, it's facing you. 90L means that the target's left wing is facing you; 90R means you're looking at the right wing. When a ground target or ship is targeted, the aspect indicator reads XXXX.

This is the numeric equivalent of the aspect angle indicator in the center of the HUD (see *HUD Flight Information* above).

Closure

Appears beneath the range indicator showing the target's speed relative to yours. A positive closure means the target is approaching you, a negative closure means it is moving away.

Hit Probability

Shows the weapon's current hit probability. The percentage takes into account all factors which may affect the missile's overall chance to hit — such as weather — but does not consider enemy maneuvering.

IN RNG appears next to the hit probability when the target is within the weapon's minimum/maximum range.



Note that your missile must have a *lock* – not just a minimum hit percentage – in order to have any chance of hitting.

Offscreen Target Marker

The Offscreen Target Marker shows the shortest path to your current target. In order to follow the shortest path, roll your airplane until the marker is at the top of your screen, and then pull back on the stick. As long as the marker

remains at the top of the screen you're following the shortest path.

Range

Indicates the range to the target in nautical miles (nm).

TD Box

The target designator box, or TD box, is superimposed on the HUD over the target, even if the target is outside of visual range.

Weapon Type & Quantity

Displays the number and type of the currently selected weapon.

HUD in Missile Mode

In missile mode, the HUD shows not only the missile type and number remaining, but information that's useful in achieving the best launch conditions for the weapon.

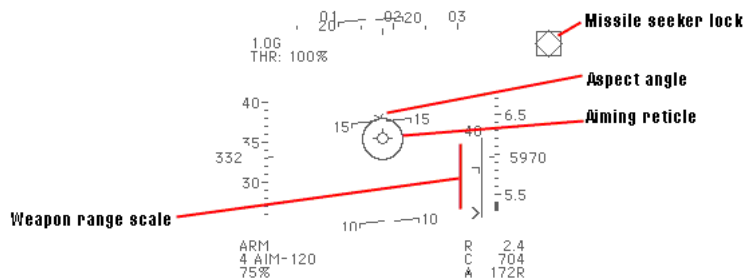

Aiming Reticle & Aspect Angle

The center of the HUD displays the aiming reticle, which is the center of the missile seeker's field of view. This circle remains fixed while the aspect angle indicator moves around it. The aspect angle indicator shows the angle between the target's flight path and your line of sight to the target.



If the aspect angle indicator is at the top of the aiming reticle, the target is heading directly toward you. If it's at the bottom of the aiming reticle, the target is heading directly away from you. If the indicator is along either side, you are looking at his wing.

For hints on using the aspect angle information to your advantage, see [Chapter 6: Advanced Combat Techniques](#).

Weapon Range Scale

The vertical scale to the side of the aiming reticle shows your weapon's minimum and maximum range. The scale range is listed at the top of the indicator. The target marker indicates where the current target is in the missile's range. If the target is outside of the missile's range, the target marker is not displayed.

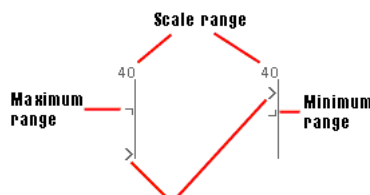

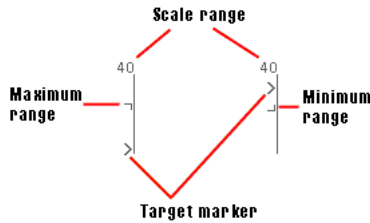

Missile Seeker

The missile seeker is represented by a floating diamond on the HUD. When the missile seeker acquires the target, a flashing diamond appears in the TD box. This indicates the missile is tracking the target and can be fired, but does not indicate if you are in a good firing position.

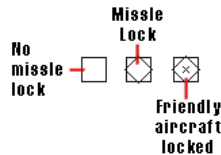

HUD in Guns Mode

The HUD in guns mode shows the number of rounds left in your internal gun. In addition, your gunsight changes depending on whether you're attacking with radar on or radar off.

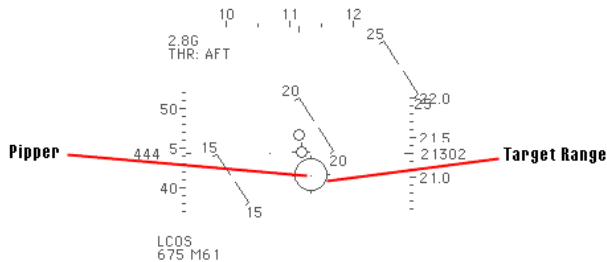

When your radar is off, the pipper is set to indicate where a bullet will fall at 1,000 feet. If a target is beyond this distance, you need to lead the target more. If the target is less than 1,000 feet, you need to lead it less.

With radar on and your target locked, the pipper changes range to match that of the target and automatically calculates lead requirements. For you, this makes life simple — just place the pipper on the target and fire. Your active radar also provides your gun computer with range information. As you close in on your target, a thick line moves along the perimeter of the pipper. This circle measures range from your current position to the target. When there is no thick arc on your pipper, your chances of hitting are zero. When the arc has filled in the pipper, your chances of scoring a hit with a well-aimed shot are excellent.

HUD in CCIP Mode

CCIP stands for Continuously Calculated Impact Point. The HUD in CCIP displays all the symbology necessary to accurately strike ground targets with unguided bombs.

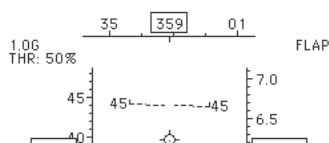

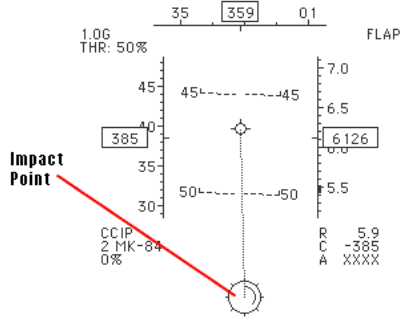

The dotted line extending from the center of the HUD indicates which path the bombs will follow upon release, and the impact point pipper shows where the bomb will land. In level flight, you often can't see the pipper on your HUD; to see the pipper, you must either dive or significantly increase speed. The slower you fly, the steeper you must dive to keep the CCIP pipper on the screen.

An arcing line moves inside the CCIP pipper. This circle measures range from your current position to the drop point. When the inner arc forms a complete circle the target point is 10,000 feet or more away. When the inner arc forms a half-circle, the target point is 5,000 feet away. Accuracy reduces as range increases, effectively limiting bombs to a 2 nm range. Beyond this range your chances of hitting the intended target are very low.

The HUD In Navigation Mode

Navigation Mode provides you with the information you need to fly to pre-established waypoints and make successful carrier landings. To switch between Weapons Mode and Navigation Mode, press **N**.

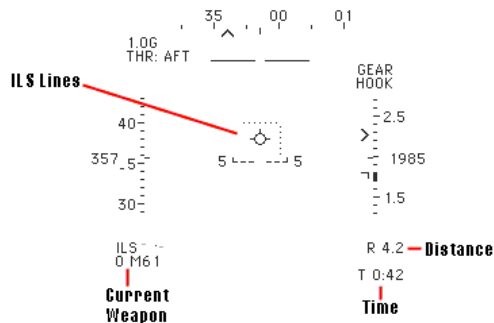

Current Weapon

The current weapon is always displayed in the event that you need it.

Distance

The distance to the current waypoint in nautical miles (nm).

Time

The time to the next waypoint based on your current airspeed in minutes:seconds

ILS System

The instrument landing system, or ILS, provides landing guidance. The ILS

displays horizontal and vertical lines on the HUD which guide you to the carrier during landings, especially when the deck is obscured by bad weather or darkness. ILS lines are displayed only when you are in a landing configuration.

The ILS automatically displays on the Navigation mode HUD under the following conditions:

- Gear and hook down
- Within 5nm of the carrier
- Under 2,000 feet of altitude.

The ILS lines show where your aircraft needs to fly. The horizontal line shows your altitude and the vertical line shows how well you are lined up with the runway. The dots are tightly spaced when following a good approach and loosely spaced when outside approach parameters. When the dotted lines form a cross in the center of your HUD, you're on the glide path for a correct landing.

For more information on ILS operation and carrier landings, see [Chapter 4: Carrier Qualifications](#).

Instrument Windows

All instruments except the HUD are displayed in user-selectable windows. You select only the windows you need for the current task, saving screen space and increasing the speed of the game by closing non-necessary windows.

Flight Envelope Window

Shift - 1

The Flight Envelope Window shows your aircraft's current state within its flight envelope.

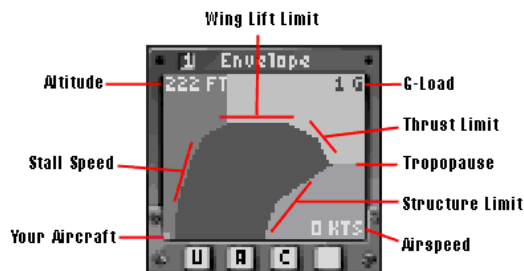

The flight envelope is basically a series of graphs showing the aircraft's minimum and maximum speed and altitude and its turn performance. With the Flight Envelope Window, you can graphically see how your aircraft is performing within the following limits:

Stall Speed

The stall speed curve graphs the altitude and speed at which stalls occur. If the dot representing your aircraft moves toward the left side of the envelope, you need to pick up speed or a stall is imminent.

Wing Lift Limit

The wing lift limit curve represents the aircraft's ceiling. The aircraft can't climb above this altitude because the air is too thin — not enough lift can be

generated to overcome the airplane's weight. If the dot representing your aircraft hits this upper limit, nothing will happen; however, since you're in your 1g envelope, you won't be able to do much in the way of maneuvering.

Thrust Limit

The thrust limit curve represents the limit of your engines at high altitude. Above the tropopause (36,600), your engines can't produce enough thrust to go beyond certain speeds. If the dot representing your aircraft hits its thrust limit, nothing will happen — you simply can't go any faster.

Structure Limit

The structure limit curve represents the maximum speed your airframe can handle. Go too far beyond this limit and your wings will tear off. If the dot representing your aircraft approaches this limit, think about slowing down immediately.

G-Load

Each flight envelope is defined by the number of g's your aircraft can pull. G-loads measure your aircraft's turning. This is explained in detail in [Chapter 3: Flight School](#), however, the window can be explained here briefly. To simplify, the more G's you're pulling, the harder you're turning. The number of G's you can pull are limited by the following factors:

Altitude	At higher altitude, where the air is significantly thinner, the wings cannot generate as much lift. As a result, you can pull fewer G's at high altitude than at low altitude.
Speed	The faster you're going, the fewer G's you can pull.
Structure	An aircraft is built to endure only a certain amount of G-force. Beyond that range, the airplane's structure is fatigued to the point that the wings crack.
Pilot	Humans can only tolerate a certain amount of G-force stress. Too many seconds of + 9g maneuvering and you black out. Maneuver too long at - 5g and you experience "red out."
Load	Amount of ordnance and fuel you're carrying. The more weight on your airplane, the fewer G's you can pull.

The Flight Envelope Window is useful for quickly seeing the number of g's available to you at any time. If you get involved in a turning fight with an opponent, you typically want maximum g's in order to out-turn your opponent. Depending on the combat situation, you may want to be in the smallest (highest G) envelope in the window. When used with the Corner Speed Indicator on the HUD, you can determine what speed will give you the best turn performance and what you need to do in order to achieve it. Note: The G's shown in the Flight Envelope are for "clean" aircraft not loaded down by ordnance. Since weapons increase both weight and drag, you may not be able to pull the maximum G shown depending on your weapon load.

For more details on corner speed, see [Chapter 3: Flight School](#).

Flight Envelope Window Modes

The Flight Envelope Window has three buttons along the bottom which modify the flight envelope display.

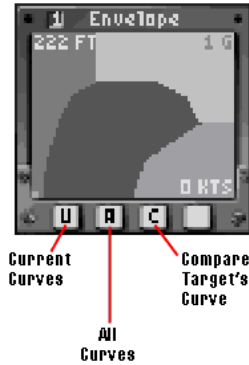

Current Curve

Displays the the envelope for the G-load currently being experienced by your aircraft. For example, when flying straight and level at 450 kts and 1g, the 1g curve is displayed. When flying at 450kts at 3g, the 3g curve is displayed.

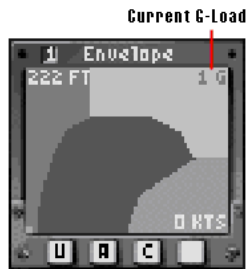

All Curves

Displays the flight envelopes for all G-loads your aircraft is capable of. This mode is useful for seeing how close you are to the “next” envelope and gives you a clue as to how you can increase G. For example, if the dot appears on the far left side of the graph, you’re moving too slowly to pull much G — you should add thrust and/or sacrifice altitude for speed. If the dot appears near the top, you’re already at maximum altitude — you should decrease altitude quickly (via a Split S, for example). If the dot appears near the right side of the graph, you’re moving too fast to pull more G — you should climb or simply put up your brakes.



Compare Curves

Displays your flight envelope over that of your currently selected target, providing you with a quick comparison of aircraft performances.. Areas where the opponent holds the advantage are shaded red.

You must have a target lock to use this display mode. For more information on locking a target, see *Targeting Commands* in *Chapter 5: Fundamentals of Air Combat*.

Forward View Window **Shift - 2**

Since you can't always look ahead during a dogfight, the Forward View Window gives you a look at where you're going while your head is turned. This compensates for the fact that in reality you can shift views more quickly than in a simulation.

Other View Window **Shift - 3**

The Other View Window lets you choose another view and display it throughout the mission. To set the window's view, switch to another view (**F2 - F12**). Press **V** to set the view as your Other View. The Other View Window automatically appears.

Target Window **Shift - 4**

The Target Window lets you view your currently selected target and see data on its skill and activities. Note: When using TV- or laser-guided bombs, the view from the missile is displayed this window until the missile explodes.



Activity

A target's Activity tells you what specifically he's doing in order to complete his Tactical Goal. This can range from SEARCHING for other opponents to ACQUIRING, PURSUING, or doing one of many maneuvers.

Bearing

The target's bearing is represented by hours on the clock, with 12 o'clock being the nose of your airplane and 6 o'clock being your tail. Hi and Lo provide a general idea of the target's altitude relative to your own.

Damage

Damage to the target is indicated by the vertical bar on the right side of the window. White represents damage to the target. When the bar is completely black, the target has taken no damage. When the bar is completely white, the target is destroyed. Damaged computer opponents suffer reduced turn performance and reduced thrust.

Tactical Goal

A target's Tactical Goal can be one of four things, represented by one of the following markers:

Marker	Goal	Description
A	Attack	Attack something other than you.
N	Neutral	Follow waypoints and fulfill mission.
E	Evade	Evade something other than you.
A	Attack Player	Attack you specifically.
E	Evade Player	Evade you specifically.
C	Crash	Die screaming.

Range

The distance of the target from you, measured in nautical miles (nm).

Skill

The pilot's skill is shown by dots in the following manner:

# of Dots	Skill	Description
None	Novice	An easy target. Don't expect fancy maneuvers from this guy.
One	Average	Hard to tell if this guy's a turkey or an eagle.
Two	Experienced	Don't expect an easy fight. This guy's got some cards up his sleeve.
Three	Ace	A pro. He'll turn and burn with you until one of you earns yourself a nylon letdown.

Type

Displays the type of target you're facing.

RWR Window

Shift - 5

The Radar Warning Receiver (RWR) Window displays all active radar sources around your aircraft.

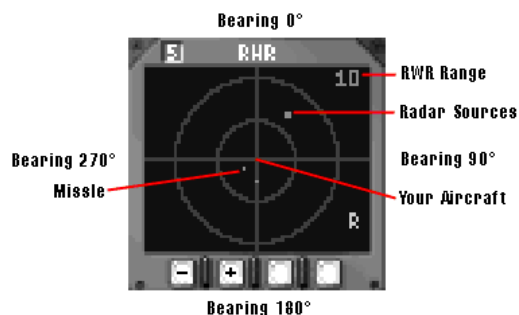

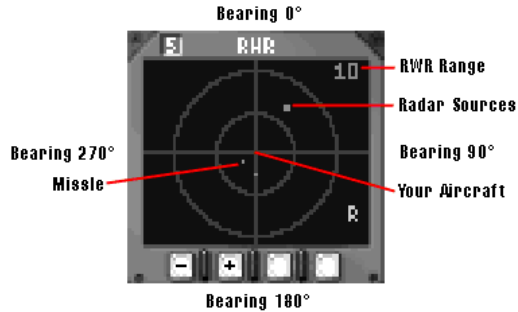

The center represents your aircraft, with the top of the display indicating what's in front of you and the bottom of the display indicating what's behind you. All received radar sources appear as a green dot around your aircraft, relative to your current position. The selected range is displayed in nautical miles in the upper right corner.

When a radar source is detected a small "R" is displayed in the lower right corner of the RWR. A bright "R" indicates that the aircraft has a lock on you and may fire on you soon. If the "R" begins to flash, a missile is currently locked on you and in flight. Your RWR also gives you other information not available in the real world: it can detect infrared seekers, indicated by a small "I" in the lower right corner. The "I" functions identically to the "R" — a bright "I" means an IR-homer is locked on you, and a flashing "I" means a missile is headed for you.

Missiles appear on the RWR as smaller dots. Rapid flashing indicates the missile is actively tracking you. Your missiles will also appear on the RWR, so pay attention. Lastly, the RWR shows the status of your jamming equipment, displaying "JAM" when your ECM gear is activated.

Changing RWR Range

Press **period** (.) to increase RWR range. Press **comma** (,) to decrease RWR range. Maximum RWR on any aircraft in *U.S. Navy Fighters* is 50 nm.

NAV Window

Shift - 6

The NAV Window shows bearing and range to waypoints along with the estimated time of arrival (ETA) in minutes:seconds. The currently selected waypoint is always highlighted.



Waypoints must be manually selected except when the autopilot is in operation. Press W to switch to the next waypoint, or press Shift-W to go to the last waypoint. Alternately, you can change waypoints by clicking on the + and - buttons at the bottom of the NAV Window.

"Bearing" is not the heading you must fly, but the number of degrees you must turn in order to fly directly at the waypoint. If the bearing is negative, turn left. If

the bearing is positive, turn right.

System Status Window **Shift - 7**

The System Status Window displays throttle, engine temperature, oil pressure, and hydraulic pressure. This view is useful for assessing systems damage and viewing fuel levels.



Stores Window **Shift - 8**

The Stores Window displays the number and type of weapons the aircraft currently carries and how much fuel is remaining.



You can change your current weapon using the **square bracket** keys ([]). Alternately, you can change current weapons by clicking on the + and - buttons at the bottom of the Stores Window.

Radar Window **Shift - 9**

The Radar Window displays your radar scope (in a two-seater, that of your RIO). The window will appear only if your radar has been activated (press **R**). Deactivating your radar (press **R** again) automatically closes the radar window.

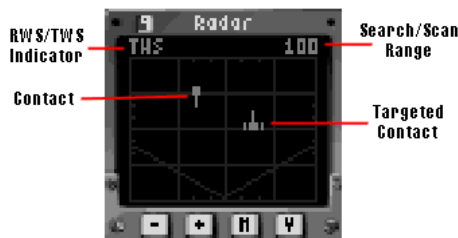

The Radar Window is a top-down view. The nose of your aircraft is in the center of the bottom edge of the window. The top edge represents far edge of radar coverage. Contacts appear as dots on the grid.

Your radar can detect aircraft and large surface objects such as ships. Interference from the ground prevents your radar from detecting tanks or small vehicles. To detect these targets, you need to carry either an infrared detector or HARM missiles, which home in on enemy radar emissions.

TWS/RWS Indicator

The TWS/RWS Indicator indicates whether the radar is in Range While Search (RWS) or Track While Scan (TWS) mode.

Range While Search (RWS) mode uses continuous wave emissions to provide contact range and bearing at extremely long ranges. Primarily a scanning mode, RWS cannot provide detailed tracking information. You cannot target a contact while in RWS mode. RWS mode engages automatically when you increase radar range past maximum tracking range.

Track While Scan (TWS) mode uses pulse-Doppler radar to target a designated contact, thereby providing detailed tracking information, while still providing scanning of other nearby contacts. TWS mode automatically disengages when you increase radar range past maximum tracking range.

Aircraft	Max RWS Range	Max TWS Range
A-7	150 nm	50 nm
F-104	150 nm	25 nm
F-14	150 nm	150 nm
F/A-18	150 nm	50 nm
F-22	150 nm <td 150 nm	
Su-33	150 nm	100 nm

Radar Contacts

Contacts appear as dots on this grid based on their range from your aircraft. For example, with a 100 nm range selected a contact at 50 nm would appear in the middle of the display, a contact at 75 nm would appear near the top, and a contact at 10 nm would appear near the bottom. If you decrease range to 50 nm, the 75 nm contact disappears and the others both move closer to the top of the display.

At long range, radar may be unable to distinguish between multiple targets flying closely together. A tight formation of two MiG-29s at 100 nm may appear as a single dot on your radar until you get much closer. Beware of single contacts: they may unexpectedly multiply!

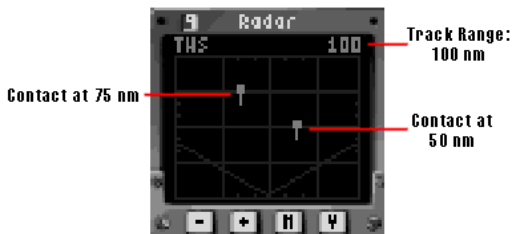

Aircraft appear as small squares. In TWS mode, a small “tail” on the target indicates the contact’s heading relative to your heading. When a contact is targeted, two vertical lines, called “captain’s bars,” surround the designated contact. Surface targets appear as single-pixel dots.



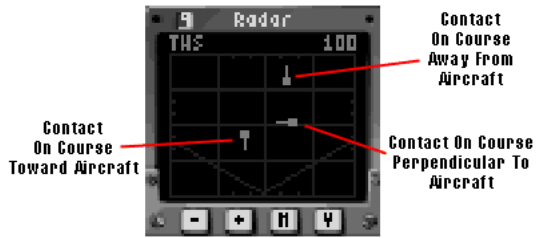

Target Elevation & Azimuth

Two arrows move along the left and bottom edges of the radar window. The arrow along the left edge shows the target's altitude relative to your own. If the target is beneath the plane of your nose, the elevation indicator moves below center. If the target is above the plane of your nose, the elevation indicator moves above center. The bottom arrow indicates target azimuth, or horizontal displacement. If the target is left of your nose, the azimuth indicator moves left of center and vice versa.

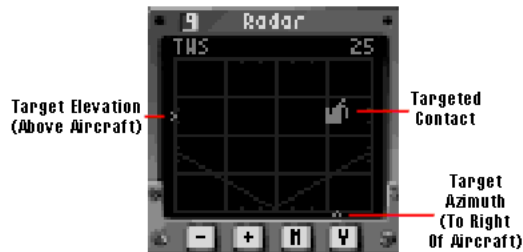

Increasing/Decreasing Radar Range

Press period (.) to increase radar range. Press comma (,) to decrease radar range. Maximum RWS and TWS ranges are listed above.

Historical Mode

Press **Y** to activate your radar system's historical mode. This displays a series of dots behind a contact giving a visual representation of the contact's movement over time. Alternately, you can click on the Y button on the Radar Window.



IR Mode/HARM Mode

The Radar Window is also used for aircraft carrying infrared sensors or HARM missiles.

Airplanes equipped with the AAS-38 FLIR IR-sensor can detect target objects based on their infrared signatures. The IR-sensor has two advantages — it allows you to detect ground targets, and enemies are not aware that you've targeted them. Unfortunately, it's less effective in bad weather than radar, and

it's short range limits you to close engagements.

•

Note that the SU-33, SU-27, and MiG-29 all have built-in IR sensors.

Press I to turn off your radar and activate the IR-sensor, or click on the “M” button on the Radar Window. You designate targets with the IR-sensor exactly as you would with your active radar. If you want to return to active radar mode, press R.



If your aircraft is carrying HARM missiles, press M to turn off your radar and turn on the radar-homing seeker used by the missile. The HARM missile is deadly against enemies employing radar. You designate targets for the radar-homer as you normally would for your active radar. If you want to return to active radar mode, press R. For more information on IR and HARM modes, see [Chapter 5: The Fundamentals of Air Combat](#).

Authentic vs. Standard Radar CRT

The Standard Radar CRT is a top down view of what's in front of your airplane.

Authentic Radar mode works differently. It's basically a graph with vertical lines indicating angles off your airplane's nose and horizontal lines indicating range.

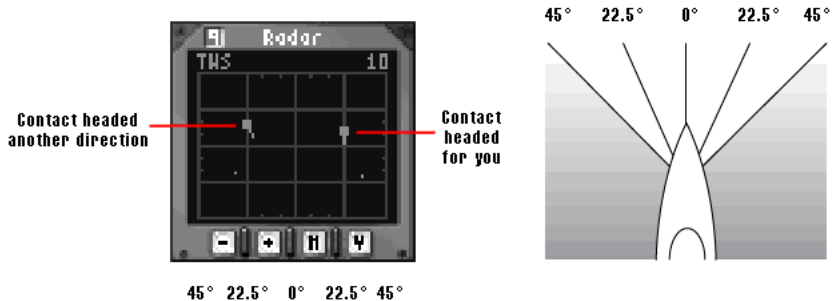

To figure out where a contact is, you must count over horizontally to its approximate angle off your nose, and then go up to determine range. Contacts are also displayed differently on the Authentic Radar CRT. The “tail” indicating the contact's flight path is relative to its angle off your nose. For example, a contact with its flight path “tail” pointing down is actually headed directly for you.

View Controls

Lose Sight, Lose The Fight - Motto, US Navy Fighter Weapons School

The fanciest flying in the world will still get you killed if you don't know where the bandit is. Keeping visual contact, or tally, on the bandit is arguably the most critical aspect of aerial combat.

Fixed Views

Key	View	Description
F1	Forward	Look ahead. This is your normal view — when in doubt, press F1.
F2	Back	Look over your tail at what's behind you. This is your "check six" key.
F3	Up	Look above the standard F1 view. This is useful in a turning dogfight.

Tracking View

Key	View	Description
F4	Tracking	This view follows the current target within the bounds of normal head rotation.

External Views: Player Referenced

Key	View	Description
F5	Player -> Threat	External view of your aircraft, facing any inbound missiles.
F6	Player -> Wing	External view of your aircraft, facing your wingman.
F7	Player -> Target	External view of your aircraft, facing your current target.

External Views: Other

Key	View	Description
F8	Target -> Player	External view of your current target, facing your aircraft.
F9	Fly By	External view of your

		aircraft from a fixed point as it flies by.
F10	External View	External view of your aircraft.
F12	Missile -> Target	External view of your missile, facing its current target.

View Reference Keys

The Alt and Ctrl keys change which object your view is referenced from. Pressing Alt makes the current view relative to your target instead of your aircraft. Pressing Ctrl makes the current view relative to your last launched missile instead of your aircraft.

View Panning & Zooming

The internal views and fixed external views can be rotated or panned using the arrow keys. Use the cursor arrow keys (or Ctrl and the arrow key if not using a joystick for flight control) to change your perspective.

Alternatively, you can pan your view by holding down Right Shift and moving your joystick. This command is good for looking around during combat.

Use the plus (+) and minus (-) keys to increase and decrease view magnification.

Inflight Menu Bar

Pressing Esc during flight activates the inflight menu bar. The inflight menu bar has five menus:

Pref Menu

Option	Key Equivalent	Description
Stick		Choose a control device for your flight stick: Keyboard, Joystick, or Thrustmaster FCS
Rudder		Choose a control device for your rudders: keyboard or rudder pedals.
Throttle		Choose a control device for your throttle: keyboard or throttle stick.
Graphics...		Shows the Graphics Prefs selection panel, which allows you to turn

		various graphic effects on and off. See the <i>Install Guide</i> for a complete discussion of the Graphics option.
Sound...		Shows the Sound/Music Prefs selection panel, which provides volume control for various sound and music effects. See the <i>Install Guide</i> for a complete discussion of the Sound option.
HUD Pitch Ladder?		When activated, displays the pitch ladder on the HUD.
Dim HUD	Shift - [Reduces the brightness of the HUD.
Brighten HUD	Shift -]	Increases the brightness of the HUD.
View Transitions?		When activated, you see “transitions” when shifting views. If this option is not activated, you “snap” from one view to another.
Authentic Radar CRT		When activated, displays an “authentic” radar CRT in the Radar Window. If this option is not activated, the Standard Radar CRT is shown. See Authentic vs. Standard Radar CRT .
Cockpit?	backspace	When activated, displays the cockpit.
Rear View Windows?		When activated, rear view windows in the cockpit let you watch your six. Note that your cockpit must be displayed in order to see rear view windows.
Radio-Silence?	Alt-S	When activated, you don't hear your wingman

or RIO chatter. They reserve their messages for the most important situations, such as missile launches.

View Menu

The View Menu allows you to choose from *U.S. Navy Fighters'* different views. See [View Controls](#).

Window Menu

The Window Menu allows you to choose from *U.S. Navy Fighters'* different Instrument Windows. See [Instrument Windows](#)

Cheat Menu

Invulnerable?	When activated, makes you invincible to enemy fire and crashes.
Unlimited Ammo?	When activated, provides you with unlimited ammo. Note that the types of weapons you're carrying remain the same.
Unlimited Fuel?	When activated, provides you with unlimited fuel.
Easy Aiming?	When activated, near misses with your gun become hits.
No Crashes?	When activated, you can crash into the ground and live to tell about it.
No Spins?	When activated, your airplane will never go into a spin.
Extra G?	When activated, you can pull a few extra G's over your normal limit.
Ignore Weapon Weights?	When activated, your airplane will perform as if it were carrying no

weapons.

No Sun Whiteout?

When activated, you see no glare when staring into the sun.

No Redout or Blackout?

When activated, you do not suffer redouts or blackouts from excessive positive and negative G-loads.

Ignore Mid-Air Collisions?

When activated, you cannot collide with another airplane.

Show Target Info?

When activated, target info appears below targets on the main view. Target type is indicated. If the target is an airplane, its current maneuver appears as well. The information is orange unless the object is targeting you, in which case it appears in red.

Air Combat Guns Only?

When activated, all air-to-air missiles are removed from all aircraft.

Chapter 3

FLIGHT SCHOOL

Piloting an aircraft requires an understanding of aerodynamics. For a fighter pilot this is more than just a question of safety. In combat, a firm grasp of the fundamental principles of flight is the difference between life and death. Air combat usually boils down to a fight to out-turn your opponent, point your nose at him, and fire weapons. Understanding how and why your aircraft turns under various circumstances is essential for combat success.

Pitch, Roll & Yaw

Aircraft maneuver in three dimensions: pitch, roll, and yaw. These dimensions are always referenced from the pilot's point of view, regardless of the aircraft's orientation or flight attitude.

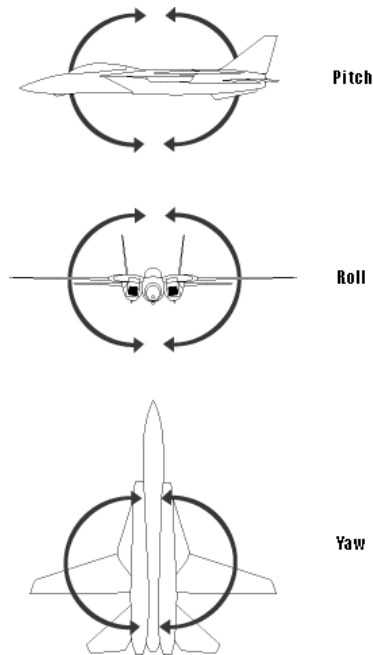

Pitch is the movement relative to the horizontal plane realized by the nose and tail moving in opposite directions (normally up and down). Pitch is controlled by the aircraft's *elevators*.

Roll is the movement relative to the aircraft's longitudinal axis realized by the wingtips moving in opposite directions (normally up and down). Roll is controlled by the aircraft's *ailerons*.

Yaw is the movement relative to the vertical plane realized by the nose and tail moving in opposite directions (normally sideways). Yaw is controlled by the aircraft's *rudders*.

Flight Controls

You control the aircraft with three primary controls, the flight stick, the rudder pedals, and the throttle.

Flight Stick

Moving the stick forward and back moves the aircraft's elevators and causes a change in pitch. Pulling the stick back, called *applying aft stick*, causes the aircraft's nose to rise. Pushing the stick forward — *applying forward stick* — causes the aircraft's nose to lower.

Moving the stick right and left, called *applying lateral stick*, controls the ailerons. For example, moving the stick left causes the left wing to drop and the right wing to rise, rolling the aircraft left.

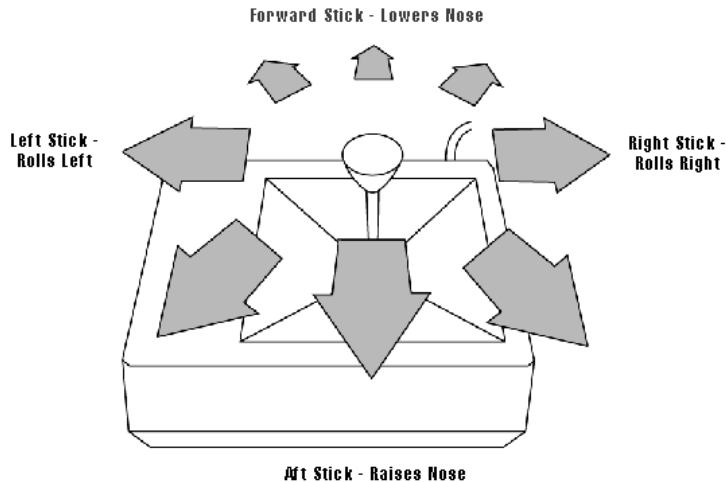

Rudder Pedals

The rudder pedals move the aircraft's rudders, controlling yaw. Applying right rudder yaws the aircraft's nose right. Pushing the left rudder yaws the aircraft's nose left.

Rudder usage also induces roll. When using rudder, most aircraft will roll the direction rudder is applied. The amount of roll varies with aircraft type. Some aircraft, like the F-104, roll the opposite direction of rudder inputs.

In *U.S. Navy Fighters*, flight controls are automatically coordinated, so rudder usage is not required for normal flight. Rudders are primarily used for lining up gun shots and spin recovery.

Throttle

The throttle controls the engine's output. Pulling the throttle back closes the throttle, decreasing engine output. Rapidly closing the throttle is called cutting or chopping the throttle. Pushing the throttle forward opens the throttle and increases engine output. The engine's maximum output without using afterburner is called *full military power*.

The afterburner increases engine thrust even more by dumping fuel into the engine's exhaust and igniting it. It provides a significant thrust increase over military power, but consumes fuel at a frightful rate, guzzling gas about 4 times faster than military power. Afterburner provides a powerful boost, but must be reserved for critical situations.

The Four Forces of Flight

Flight is the result four forces acting upon the aircraft: *weight*, *lift*, *drag*, and

thrust. When these four forces are properly proportioned, an aircraft becomes and remains airborne. You must understand how these forces interact on your aircraft before learning how to maneuver it.

Weight

Weight is the most basic of the four forces. At all times, gravity accelerates objects toward the planet's surface at 32.2 feet per second squared. Weight, by keeping man firmly planted to the ground, prevented humankind from flying for centuries.

Lift

If weight is the most basic force, *lift* is the most important. The aerodynamic opposite of weight, lift is the upward force generated by the aircraft's wings. When lift exceeds weight, the aircraft rises. When lift equals weight, the aircraft remains at its present altitude. When lift is less than weight, the aircraft descends.

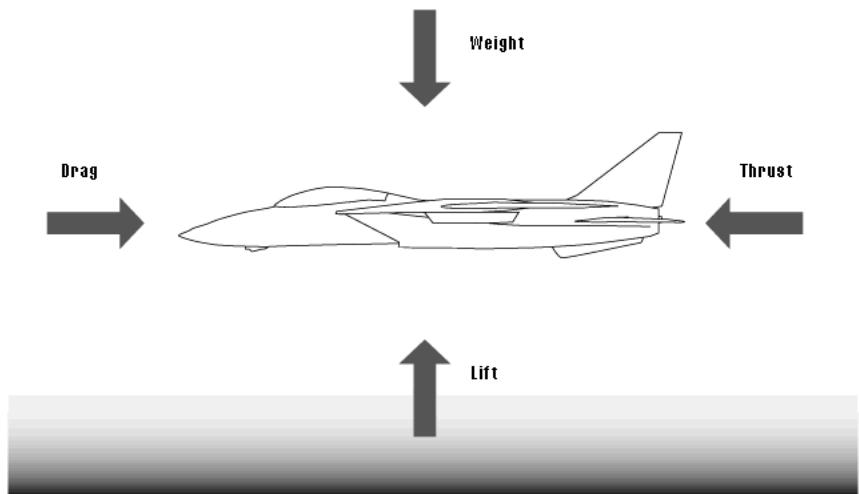

Lift is generated perpendicular to the plane of the wing. The lift vector — the mathematical representation depicting the direction of the wing's lift — pushes up when the airplane is in level flight. When the wing rolls or rotates, so does the direction of the lift vector. Your lift vector forms the basis of air combat maneuvering.

The movement of air over the aircraft's wings and tailplane generate lift. Movable control surfaces — ailerons, rudders, and elevators — alter lift to rotate the airframe around its center of gravity. These are what the pilot uses to maneuver the airplane.

Bernoulli's Principle

Bernoulli's Principle explains the dynamics surrounding the wing.

As the wing moves through the air, it splits the flow along its upper and lower edges. The curved upper surface causes the airflow to move faster over the top of the wing than below it. As a result, the faster-moving airflow on top of the wing has less pressure than the air below. Since nature abhors a vacuum, the air below moves upward to fill the low pressure zone, taking the wing with it. The result is lift.

The amount of lift generated as the airplane moves through the air is determined by two things: the density of the air at its current altitude, and the speed of the wing through the air. More lift is generated as airspeed and air density increase. Conversely, less lift is generated as airspeed and air density decrease.

The laws are easy to remember.

The faster you go, the more lift is available. Speed is important.

The denser the air, the greater the lift. Air is more dense near the ground and gets thinner the higher you go. The result: you have less lift when you're up high than when you're near the ground.

Both of these laws are influenced by the airplane's attitude: its Angle Of Attack (AOA) and its roll.

Angle of Attack

AOA is the angle at which the wing meets the flow of air. If an aircraft is flying straight and level — neither gaining or losing altitude — its wings meet the airflow at a low AOA. However, if the airplane pitches up, the wings meet the airflow at a higher angle.

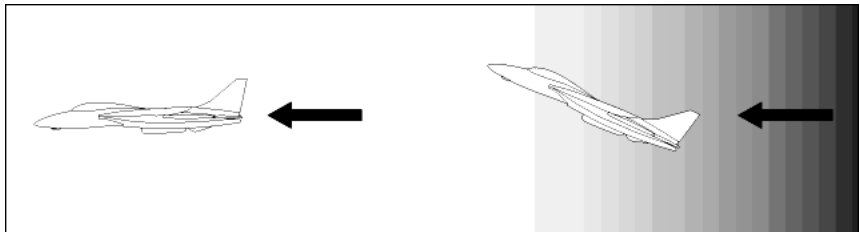

AOA is important because it causes the airflow over the top of the wings to accelerate. This in turn reduces air pressure above the wing, resulting in even more lift. In other words, lift increases as AOA increases.

Lift, however, does not increase indefinitely with AOA. The airplane requires a smooth, steady flow of air over the wing. The pilot can increase AOA to the point where the flow of air is disrupted. When this happens, lift decreases and gravity takes over — the aircraft can literally fall from of the sky. This is known as a *stall*.

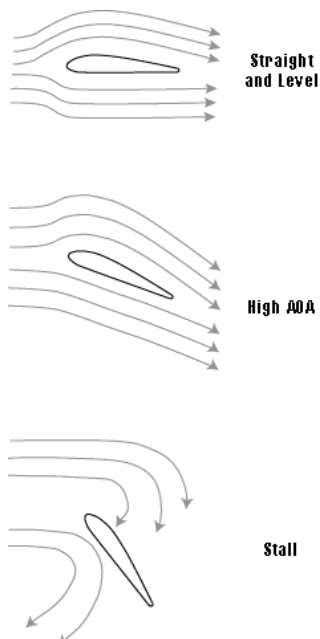

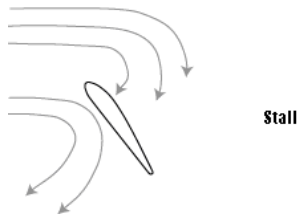
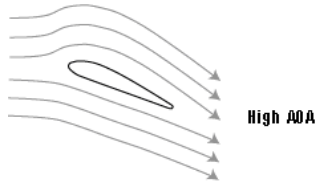
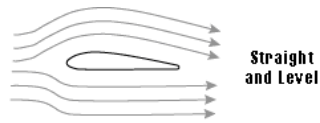

Thrust

The wing doesn't magically propel itself through the air. The force pushing it is called *thrust*.

Thrust controls the direction the aircraft travels. If an aircraft suddenly pitches up or down, its momentum causes it to continue moving along the original direction until the thrust from its engines pushes it in a new direction.

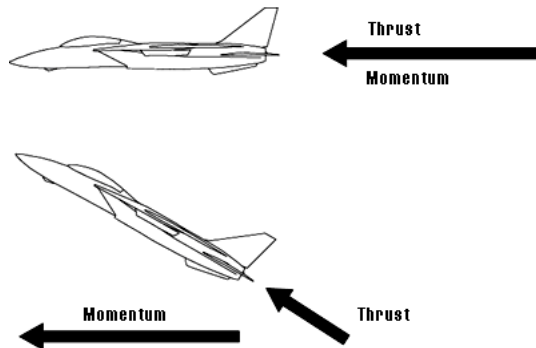

Drag

As the saying goes, there's no free lunch. Thrust produces an undesirable side effect: drag. Drag is basically resistance to air. The airplane's engines must overcome air resistance in order to push the wings through the air and create lift. Additionally, as the airplane's AOA increases, the surface area meeting the air increases, too. As a result, *drag increases with speed and AOA*.

G-Forces

The forces of lift and weight described above are measured in terms of "G," where 1g equals the force exerted by the Earth's gravity.

For an aircraft to fly, its wings must generate more than 1g of lift to overcome the 1g of weight gravity exerts on all objects. Once airborne, the wings must

maintain at least 1g of lift or the aircraft succumbs to gravity.

Apparent Weight

Angle of Attack is one factor that affects lift. What happens when the aircraft rolls?

In level flight, lift and weight are perpendicular to the wing, pointing straight up and down. When the aircraft rolls, lift and weight remain perpendicular to the wing but are no longer vertical.

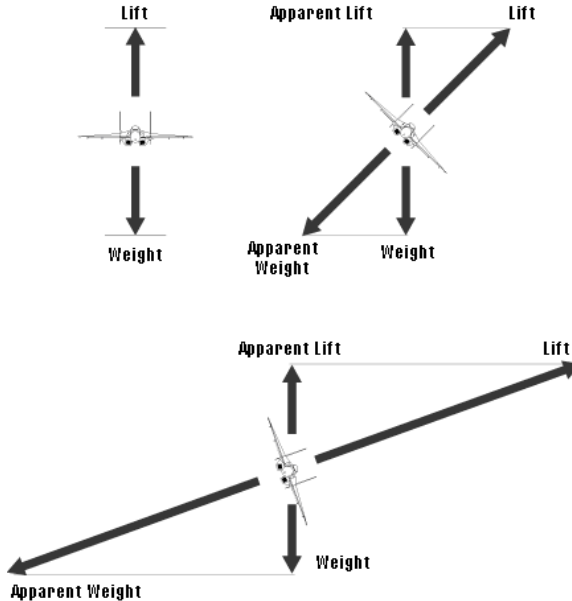

For the aircraft to maintain altitude, the vertical component must equal or exceed the weight of the aircraft. As a result, *more* lift must be generated to maintain sufficient force to offset the 1g of gravity exerted by the Earth.

As the figure above illustrates, 3g of *actual lift* must be generated to provide a vertical 1g of *required lift*. The pilot achieves this by pulling back on the flight stick. As he does so, he feels the increase of lift as *apparent weight* — in other words, the pilot actually feels 3 times heavier than normal. The same forces are at work when you're pinned to your seat in the tight turn of a roller-coaster.

As the aircraft banks even further, actual lift must be increased proportionally. For instance, as the aircraft approaches a 90 degree bank, actual lift must be increased dramatically to produce 1g of required lift. A pilot in a 90 degree banking turn may experience 8 or 9 times the normal force of gravity.

The Flight Envelope

Lift is a function of airspeed, altitude, and the aircraft's flight attitude. All of these factors work together to produce flight, and all three must be considered together when talking about how airplanes maneuver.

The aircraft's flight envelope measures all three factors. A flight envelope is a graph showing potential airspeed, altitude, and G-load. Here is the flight envelope for a fictitious fighter:

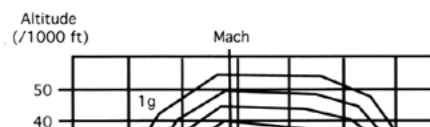

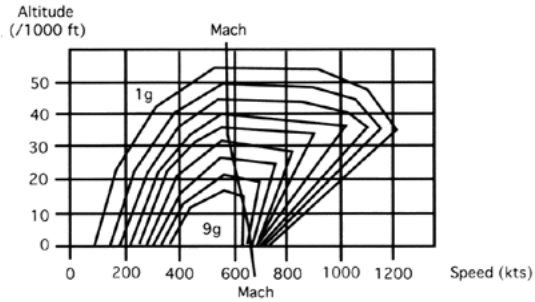

On the vertical axis is the airplane's altitude; on the horizontal axis is the airplane's speed. Plotted on the graph are curves representing G-load envelopes (severity of turn).

Absolute Limits

The outside curve shows the aircraft's speed and altitude limits at 1g (straight and level flight). This curve defines the aircraft's absolute flight parameters. The left edge plots the airplane's *minimum* speed at various altitudes. Beyond this edge, the airplane isn't going fast enough to create 1g of lift. When an airplane hits this edge of its envelope, it stalls.

The top of the curve defines the aircraft's *maximum* altitude. Above this altitude, the air is too thin (and the airplane's wing is too small) to create 1g of lift.

The right edge defines the airplane's *maximum* speed at various altitudes. Note that the airplane depicted above can fly fastest at 36,600 ft. This altitude represents the atmosphere's tropopause. Above this altitude, the air is too thin for the airplane's engines to create more thrust — the airplane simply can't go any faster. Below the tropopause the air is considerably thicker. Here the airplane's structure limits it from going any faster. If the pilot takes the airplane beyond its *structural limit*, air resistance will weaken the airframe and the wings will eventually be torn off.

G-Loading Limits

The inner curves plot the maximum G's (severity of turn) you can pull at various speeds and altitudes. You can use this information in two ways, depending on your reference point.

You can look at your current point on the graph (altitude and speed) and see *how many G's you can potentially pull*. This provides an indication of how tightly you can turn.

For example, say the aircraft shown above is flying at 40,000 ft at a speed of 700 kts. The flight envelope tells you that you could potentially pull a maximum of 3g's — a very low banking turn. If the airplane were to climb to 45,000 ft, its maximum G-load would decrease to 2g. At 49,000 ft, the airplane would scarcely be able to do much more than fly straight and level.

During combat, the Flight Envelope Window can provide you with a general notion of the number of G's you can pull. The darker the shade in the window, the fewer G's you can pull at your current speed or altitude.

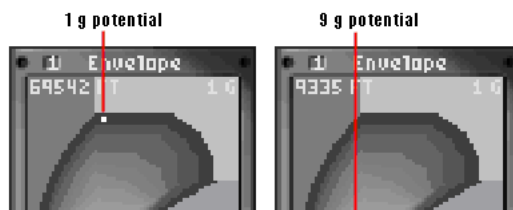

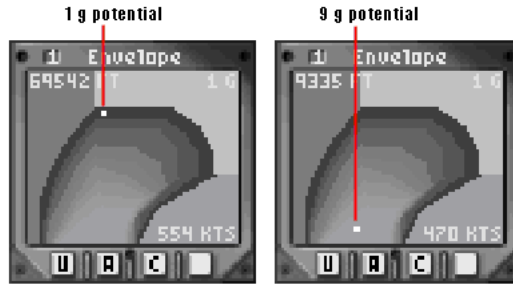

Conversely, you can look at *how many G's you want to pull* and figure out how to get there. For example, say you're near the top of your aircraft's envelope, where you can turn only one or two G's. You would need to decrease altitude and/or speed until you're in the deepest shade of the envelope.

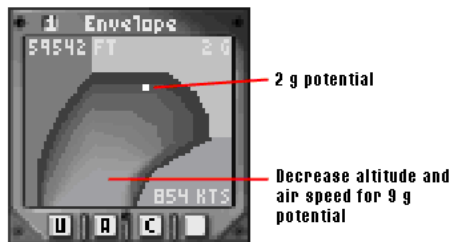

Instantaneous Turn vs. Sustained Turn

So far you've seen that lift increases or decreases according to airspeed, altitude, and the severity of the aircraft's maneuvering. These three factors interact dynamically — that is to say, they influence each other at all times. This is readily evident when considering two kinds of turns: *instantaneous* and *sustained*.

When a pilot pulls back on the stick in order to turn, more of the airplane's surface area meets air resistance. Drag increases as a result, which in turn slows the airplane down. The slower airspeed reduces the amount of lift generated. In order to maintain the turn, more thrust from the airplane's engines must overcome the greater drag.

For example, say an airplane flying at a speed of 400 kts and an altitude of 24,000 ft is capable of pulling a 5g turn.

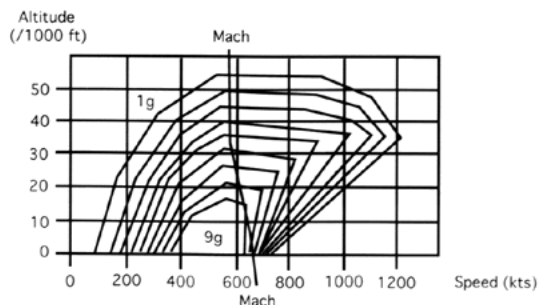

The airplane banks. The increased drag exceeds available thrust and the aircraft slows to 350 kts. The initial 5g load is called instantaneous G. It is the amount of lift the airplane can initially produce at that speed. As drag slows the airplane, it falls into its 4g envelope. With a lower G-load, drag decreases slightly. The airplane slows to 325 kts, where it can only pull 3g. The drop in G

again reduces drag. Now, drag no longer exceeds thrust and the aircraft maintains 325 kts at 3g. This is called *sustained G*. At this point, the airplane has reached equilibrium — it can maintain this speed and G-load.

Putting It All Together: Turn Performance

The number of G's you can pull is only a general indication of how tightly you can turn. G's represent the *physics* of your overall turn performance; however, *geometry* is also a factor.

Turn Rate & Turn Radius

Turn performance is measured in terms of *turn rate* and *turn radius*. Turn rate is number of degrees per second a particular aircraft can turn. Turn radius is the distance required to complete the turn. A high turn rate and a low turn radius yield good turn performance.

Corner Speed

Turn rate and turn radius depend on two variables: *airspeed* and *lift*. Both turn rate and radius improve as airspeed increases, but only to the point where maximum lift is achieved. Once an aircraft achieves maximum lift, airspeed has the reverse effect — it *reduces* turn rate and turn radius.

The point where maximum lift occurs with the least amount of airspeed is known as the corner speed. *Corner speed* is the velocity at which the best turn performance is achieved— that is, the highest possible turn rate with the lowest possible turn radius.

Using Corner Speed To Your Advantage

Flying above or below corner speed reduces your aircraft's turning performance. If you're involved in a turning fight with an enemy fighter, you want to stick to the corner speed. If the corner speed is above your current airspeed, you need to increase airspeed by adding power (igniting afterburners) or diving. If the corner speed is below your current airspeed, you need to *decrease* airspeed by climbing.

Keep in mind that your corner speed will only give you maximum g's *for your current altitude*. In other words, if your aircraft is limited by altitude to a maximum 3g turn and you reach your corner velocity, you'll only be able to pull 3g's. If you want maximum turn performance against an enemy, you need to be at an altitude that gives you your maximum G.

Corner speed at the current altitude is always marked on the airspeed ribbon by the corner velocity indicator.

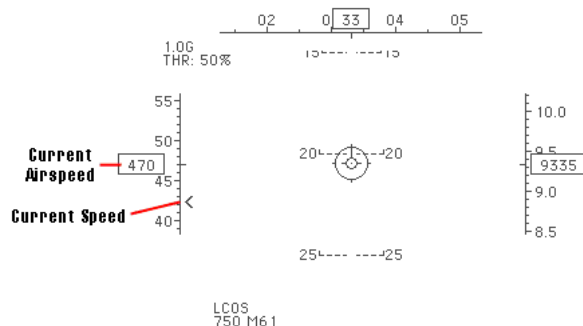

Effects of Weapon Loads

The Flight Envelope Window depicts the performance of your airplane when it's "clean," ie, not loaded down by ordnance. Since weapons increase both weight and drag, airplane performance suffers when carrying weapons. As a general rule of thumb, you can assume that G-loading suffers in proportion to the extra weight carried by your airplane. If 50% of your total weight is ordnance, you can expect a 50% reduction in the number of G's you can pull. In a bad situation you may have to reduce your weapons load to lighten your airplane. You can press Shift-K to jettison all air-to-ground ordnance. You may be unable to complete your mission, but at least you'll come home alive.

Fuel weight affects performance in the same manner. As your airplane consumes fuel during the mission, it becomes progressively lighter; however, you may be carrying external fuel tanks to increase your mission range. If you find yourself in a turning fight that isn't going right, you can jettison your excess fuel by pressing Shift-J.

Summary

Maintain corner speed is important in a turning fight with an opponent. Keep in mind, however, that every aircraft has different turning capabilities. If your opponent's airplane has a better turn performance than yours, you may want to avoid a turning fight altogether. In some instances, climbing tactics may prove better than turning tactics. *Chapter 6: Advanced Combat Techniques* describes general considerations when choosing the kind of fight you're going to engage in.

Chapter 4

CARRIER QUALIFICATIONS

Carrier operations introduce challenges not associated with land-based runways. Launching from and recovering to a moving, pitching surface less 1/10 the length of most land based runways requires special training, skill, and abilities. These are best gained by actual practice.

Preflight

It's recommended that you read the following instructions while practicing. To begin, load *U.S. Navy Fighters* and select Play Single Mission from the Choose Activity Menu.

When the Mission Selection Menu appears, select Training Mission 1. Read the mission objectives and select a F-14B as your aircraft. When the Load Weapons Screen appears, unload all of your weapons so that your hardpoints are clear. Select Fly and you're ready to go.

Takeoff

You begin on the catapult, ready to launch. Keep in mind that you can pause the game at any time by pressing Ctrl-P. When you're ready to resume flight, press Ctrl-P again.



Ready On The Cat

The cat officer, visible at the right side of your view, is signaling you to increase power. Check the upper right corner of the HUD and verify the flaps are extended. Press 6 to engage afterburner. The cat officer signals appropriately and the catapult launches your aircraft into the air.

After clearing the deck, quickly raise the gear by pressing G. Fly straight and level until airspeed reaches 200 kts, then press F to raise your flaps. Reduce throttle from afterburner to 100% by pressing 5.

Navigating

Keep the nose level and power at 100% until airspeed reaches 250 kts. Open the NAV Window by pressing Shift-6. This mission includes two waypoints. The first lies approximately 20 nautical miles due south of your carrier. Your navigation window should indicate the waypoint lies at least 30 nm at a heading of roughly 180 degrees.

When airspeed reaches 250 kts, bank left roughly 45 degrees and pull back on the stick.

Continue this left hand turn until you center the waypoint indicator under your heading readout. Watch the G reading in the HUD's upper left corner carefully; do not exceed 3g in this turn or you risk stalling out. Pull gently back on the stick until the indicator reads 3g, then hold the stick at that position. When the waypoint indicator becomes visible, begin to level the wings slowly such that the wings are level just as the waypoint indicator centers under the heading display. The bearing in the navigation window should read zero and the range should be decreasing.

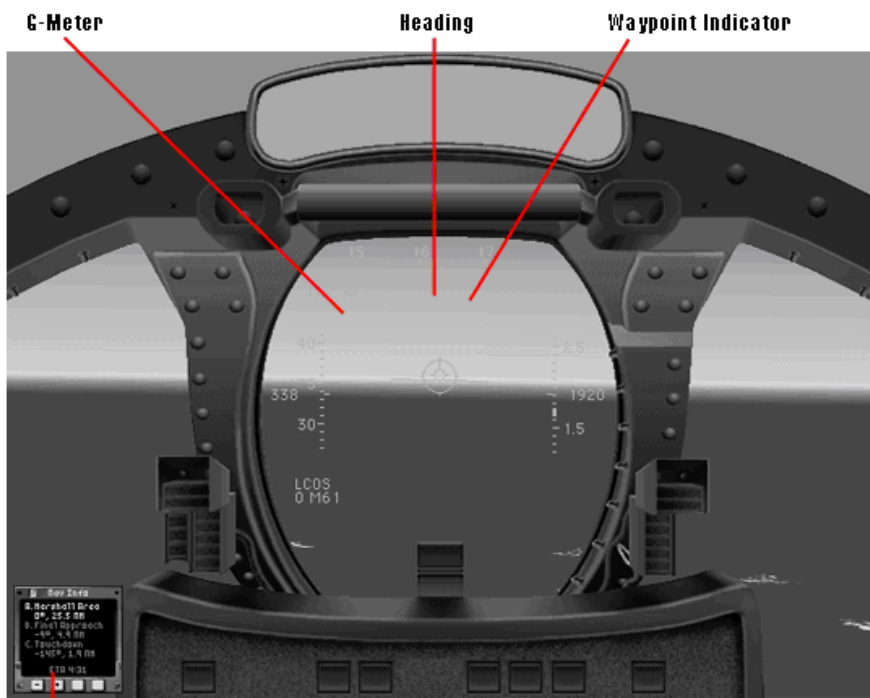

Waypoint bearing 0°

Keeping the throttle at 100%, pull back on the stick until the nose pitches up 10 degrees, and fly directly at the waypoint. When you reach 10,000 feet, gently push the stick forward and level the nose. When you get within 1nm of the waypoint, the navigation window substitutes feet for nautical miles in the range display. As you pass the waypoint, the bearing to the waypoint will change rapidly and the range increases. Fly directly at the waypoint until the heading suddenly changes and the range starts increasing again. You are now approximately 25 nm southeast of the carrier, perfectly positioned for

practicing landings.

Landing Practice

Despite the rigors of combat, landing your jet on a pitching, moving aircraft carrier may well be the toughest task you face. Little more than a controlled crash, carrier pilots must land their aircraft in a box roughly 60 feet wide and 40 feet long grabbing an arresting cable. Missing this box could mean colliding with aircraft or equipment parked on the deck; missing the arresting cable means getting your aircraft airborne quickly and trying again. Carrier landings require precision flying acquired only by practice, practice, and more practice.

Approach

A landing is only as good as the approach. A good approach usually results in a good landing. A bad approach results in a bad landing or even a crash. Executing a proper approach requires two things:

1. Profile. Know where your aircraft is supposed to be and when. Know altitude and airspeed requirements for all critical points along the approach.
2. Control. Know how to control your aircraft to meet the specified profile. A mandatory pre-requisite for understanding any approach profile.

A carrier landing always requires a positive AOA while descending, meaning the aircraft's nose will be pointed above where the aircraft is heading. Typically, you should maintain 13 to 15 degrees AOA and a constant sink rate of 500 to 700 feet per minute during the approach. How do you maintain this approach? Use this rule: *use pitch to control airspeed and throttle to control altitude*. There is no other rule or guideline as important as this.

This may sound contrary to common sense. Throttle should control speed and pitch controls altitude, right? Wrong.

During landings you use your throttle to control altitude while using pitch to control your speed. Let's illustrate this through a practical example. Your F-14 should be at about 10,000 feet and 450 kts. Set throttle to 75% by pressing 4. Pitch the airplane up. Pull back on the stick and raise the nose about 45 degrees. Watch the altitude and airspeed readouts closely. Notice that your altitude is increasing but airspeed is dropping rapidly. As airspeed slows, so does your climb rate. Eventually airspeed decays too much and the aircraft stalls.

Push the nose back down and watch the airspeed again increase. This example shows us that raising the nose, or increasing pitch, impacts airspeed more than it impacts altitude. The resultant changes in airspeed subsequently determine altitude changes. Despite the 45 degree pitch, you cannot maintain the climb rate without increasing throttle.

Practicing A "Simulated" Landing

You're going to employ this rule to your advantage by practicing a simulated landing. Imagine there's a hard deck at 5,000 ft. If you go below 5,000 feet, you've "crashed."

Climb to any altitude above 10,000 feet. First, let's analyze control response. Reduce power to 50% by pressing 3 and extend the speed brake by pressing B. As speed drops, gently pull back on the stick to keep the aircraft level. When speed drops to 280 kts, lower the gear by pressing G and retract the

speed brake by pressing B again. When speed drops to 225 kts, extend the flaps by pressing F. When airspeed reaches 180 kts, pull back on the stick and pull the nose up 10 degrees. Notice that airspeed drops quickly, followed by a loss of altitude.

Airspeed and altitude drop

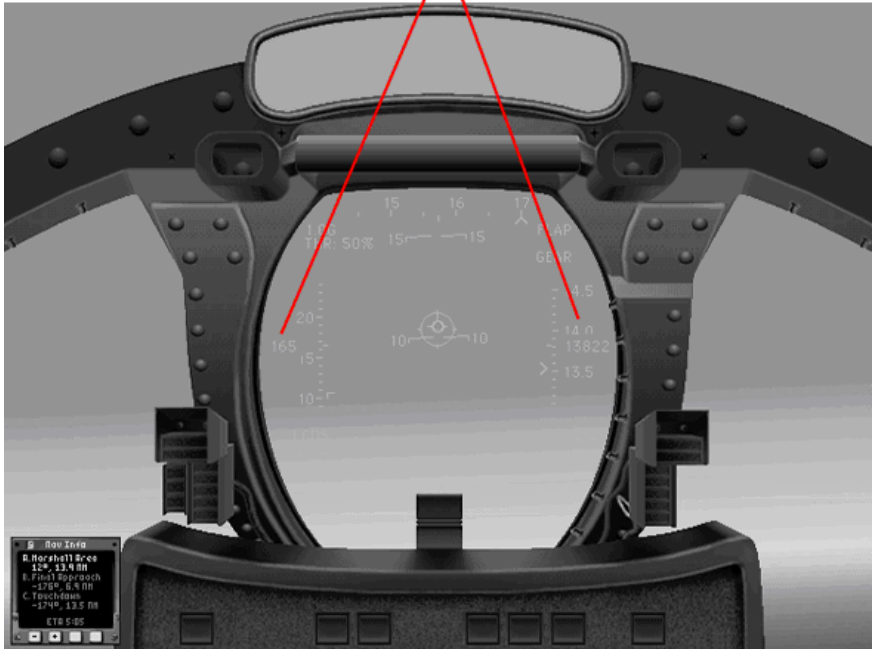

Before airspeed drops below 140 kts, increase power to full afterburner by pressing 6. Note that your speed stabilizes and your altitude decreases at a slower rate. Eventually, speed goes above 200 kts and the airplane begins to climb.

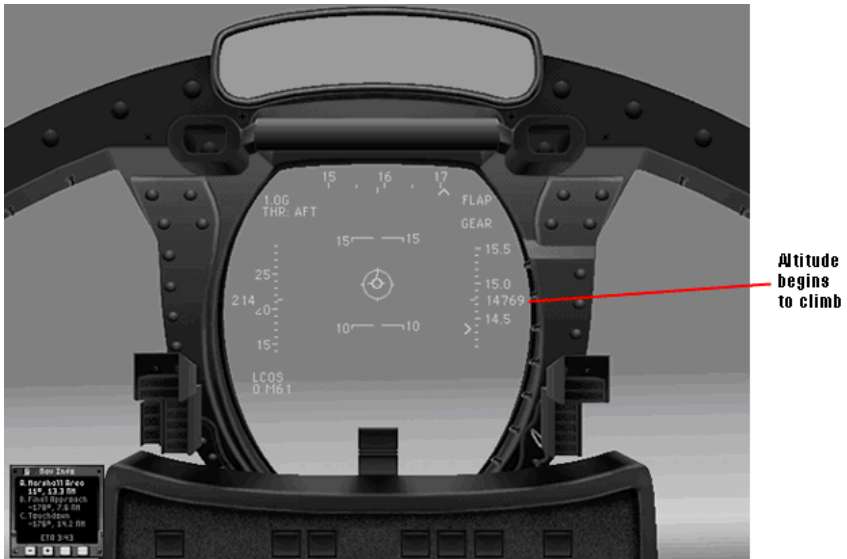

Before the aircraft exceeds 300 kts, level the nose, reduce power to 50%, and extend the speed brake until speed drops to 225 kts. As mentioned earlier, an aircraft typically maintains 13 to 15 degrees AOA during a landing. You will now use performance information you just learned to maintain a 15 degree AOA during a descent. During this exercise, keep speed above 150 kts at all

times to avoid stalling. If at any point the airspeed drops to 150, *lower the nose immediately*.

Climb to 10,000 ft again. Set power to 25% and raise the nose 10 degrees. Do not adjust the throttle during this exercise. If airspeed approaches 200 kts, extend the speed brake. Keep speed between 150 kts and 180 kts. Hold the nose at 10 degrees while the aircraft descends. If speed drops to 150 kts, lower the nose. If airspeed increases, raise the nose until it drops. Continue to work the nose up and down to maintain a speed between 150 and 180kts until you reach the hard deck at 5,000 feet.

If you maintain this speed, the aircraft *will descend*. The wings do not produce enough lift at that speed to keep the aircraft aloft. If you stall or spin the aircraft, add power, climb back to 10,000 feet, and repeat the exercise, being very careful to lower the nose before speed drops too low. If the aircraft tends to climb instead of descend, work the nose higher to control airspeed. Pull back farther on the stick, bringing the nose higher. Do not change throttle settings during this exercise. Control your airspeed throughout the descent by changing only pitch.

Next, practice controlling descent with the throttle. Climb back to 10,000 feet. Pitch the nose up 15 degrees and reduce power to 25%. As airspeed decreases, the climb rate slows. Watch the HUD altimeter closely. When altitude begins decreasing, apply more throttle. If altitude drops more than 150 feet, immediately apply afterburner. *Do not raise the nose above 15 degrees!* Raising the nose slows the aircraft more, increasing its descent rate even more. If the aircraft begins to climb, reduce power. If it climbs more than 150 feet, reduce power to 25%. While keeping the nose at 15 degrees, continue working the throttle until you can maintain a steady altitude.

When you can consistently control airspeed with pitch and altitude with throttle, you're ready to try a real landing. Descend to 6,000 feet, increase speed to 400 kts, and head directly for the waypoint. After passing the waypoint, turn to a heading of 000, due North.

Approach Profile

The approach typically begins around 20 nm behind the carrier at the marshal point, a point behind the carrier designed to align returning aircraft with the carrier. In *U.S. Navy Fighters*, the next to the last waypoint is your marshal point. Your aircraft always receives first landing clearance; all other aircraft hold marshal while you land. In this exercise, the waypoint represents the marshal point.

Departing Marshal

Turn toward the carrier (in this case, heading 000), set speed to 250 kts, and slowly descend. Altitude should be 2,000 feet when 10 nm from the carrier. Level off and hold 2,000 feet until 3 nm from the carrier. At 3nm you will enter the traffic pattern.

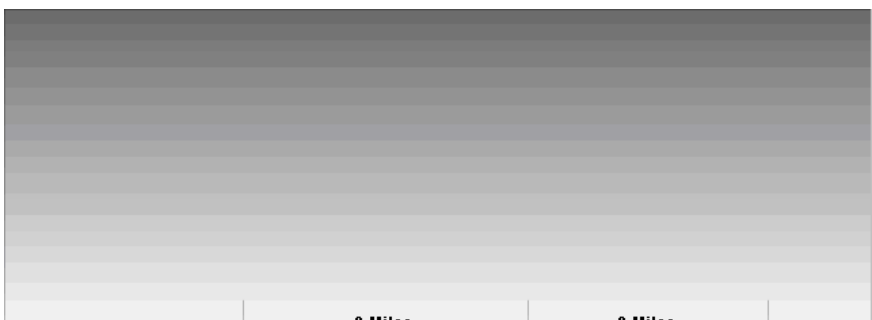

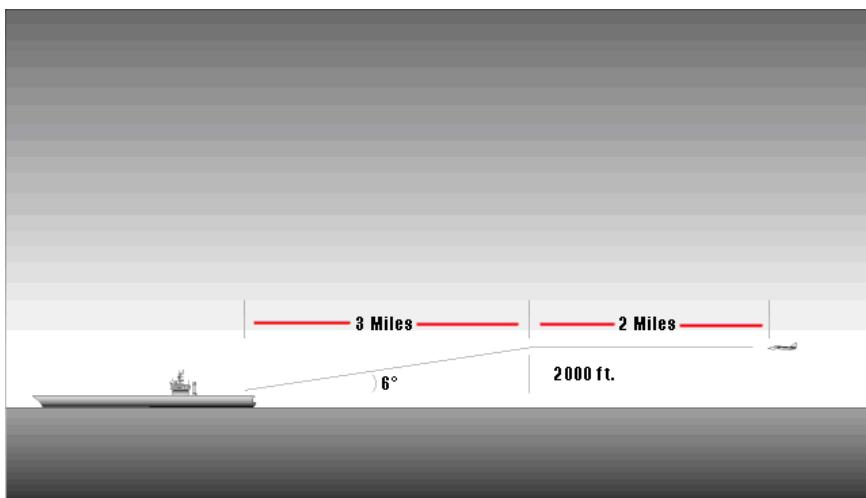

Final Approach

When you reach heading 350, you should be approximately 2 - 3 nm from the carrier at 180 kts. Because the flight deck is angled 10 degrees, your final approach heading should always be 10 degrees left of the carrier. Since the carrier is currently heading 0 degrees, your final approach heading is 350 degrees.

At this point, there are four systems which guide your aircraft down: the Landing Systems Officer (LSO), the ILS, and the HUD's flight path indicator. A perfect lineup is essential. Being off even a few feet can result in disaster, such as colliding with aircraft parked on the carrier's deck. If the lineup isn't perfect, don't land.

Landing Systems Officer

The LSO guides every aircraft during the final stages of carrier landing. The LSO can see your aircraft better than you can see the ship and gives important verbal cues to perfect your lineup. Always obey the LSO. The LSO gives the following basic commands:

"Go Right"	You are too far left. Turn right slightly to improve your lineup.
"Go Left"	You are too far right. Turn left slightly to improve your lineup.
"Higher"	You are too low. Climb immediately. Increase power.
"Lower"	You are too high. Decrease power slightly. Also, pitch the nose up more. This decreases speed and increases your sink rate.
"Call the Ball"	The LSO wants you to verify you can see the meatball. Normally, you'd respond into the radio your identification, your aircraft type, the word "ball," and how many pounds of fuel you have remaining. When the LSO hears this, he knows you can see the deck. If you cannot see the meatball, especially during bad

weather, the LSO may order a wave off.

“Go Around” or
“Wave off”

The LSO is ordering you not to land. Maybe your lineup is off, or maybe other aircraft are on the deck in the way. If the LSO orders wave off, apply full power, climb slightly, maintain current heading until past the carrier, then prepare for another try.

“Bolter”

Your tail hook did not catch any of the four arrestor cables. Apply full military power and gently climb back off the deck. Extend past the aircraft carrier and prepare for another try.

ILS

The instrument landing system appears as two lines on your HUD indicating how well your aircraft is aligned with the runway. The vertical bar, called the Localizer Deviation, indicates horizontal lineup. If you are right of the runway, the LD bar will be on the left side of the HUD and vice versa. The horizontal bar, called the Glide Slope Deviation, indicates vertical lineup. If you're too high, the GSD bar appears at the HUD's bottom and vice versa.

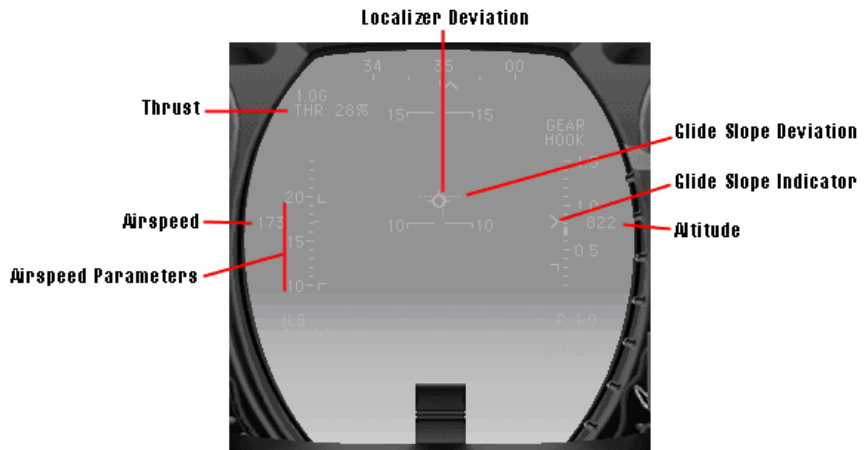

Flight Path Indicator

The HUD's flight path indicator shows where your aircraft is actually moving. Keep an eye on the flight path indicator during landing. If the flight path indicator is short of or beneath the aircraft carrier, you're sinking too fast and will crash short of the runway. If the flight path indicator is positioned past the arresting cables you're coming in long and will miss the wires.

Try to keep the flight path indicator about 13 to 15 degrees below the HUD centerpoint. This indicates an AOA of about 13 to 15 degrees, the proper approach AOA. As long as the flight path indicator is beneath the HUD center, you know your aircraft is sinking.

Complications: The Moving Carrier

The carrier continues to move during your landing. Since its runway is angled 10 degrees off, the runway will always appear to be moving to your right during a landing. You will have to make small course corrections to remain properly aligned. Do not use the rudder to correct alignment! When you change

heading with the rudder, the aircraft continues along its original course even though the nose has turned. If you turn the aircraft using the rudder, the nose will point toward the runway, but the aircraft will sideslip along its original path. Instead of using the rudder, turn the aircraft by rolling in the appropriate direction and turning toward the runway.

In The Groove: 12 Seconds of Terror

The final 12 seconds or so after calling the ball is known as “in the groove.” Your life gets very busy during these final seconds. As the Landing Systems Officer (LSO) gives you verbal flight instructions at this point you must control the aircraft’s speed and altitude using pitch and throttle, respectively to keep the ILS lines, the meatball, and the LSO happy. It’s not an easy job, and most pilots agree its as strenuous as any battle, but there’s no other place to land. You either bring it back aboard the boat or you swim home.



When the ball becomes visible, make one quick scan around the cockpit. Verify that the arrestor hook, gear, and flaps are down

The approach techniques you practiced earlier are critical during this phase. If you drift too high, cut power immediately, don't point the nose down. The nose has to be pitched up at the proper AOA at touchdown so the main gear absorb the landing shock and the hook catches a wire. If the nose is down, the nose gear takes the impact and will collapse. You can lower the nose slightly to recover airspeed, but never lower it below zero degrees. If you sink too low, don't raise the nose. Raising the nose slows the aircraft more and causes it to drop even faster. Apply full military power quickly, using afterburner if you're very slow. Keep careful watch on your speed; stalling at this altitude will result in a crash.

Any of the four arresting cables will stop your aircraft. Ideally, you will snag the 3rd wire from the back, called the “3 wire.” Why? Come in too low and you'll crash, come in too high and you'll miss all four wires. A perfect approach at perfect altitude sets you down in the middle of the four wires. Your hook then catches the next one, the 3 wire, as you move forward.

When the main gear touch the deck, apply full military power immediately. If you miss the wires you've only got a few hundred feet to get airborne again and you'll need every ounce of thrust you have. If the LSO yells "Go around!" or "Wave off!", you know you missed a wire and have to get your aircraft airborne quickly.

Waveoffs

If the LSO orders a waveoff, apply full military power immediately and climb. If you're extremely low or slow, engage afterburner. Additionally, you may have to "clean up" the aircraft, or reduce drag, by retracting flaps, speed brakes, or landing gear.

Do not change course! Continue along the landing heading (in this case 350 degrees) until you are past the carrier. Reduce engine power as soon as possible, keeping speed below 300 kts and altitude below 800 feet. Extend past the aircraft carrier, then make a left-hand turn and find the glide path again.

"Touch and Go's," using standard bolter procedures, make excellent landing practice. Follow all normal landing procedures except do not lower the hook. This allows you to practice landings without stopping.

Back On Deck

Once you've completely stopped moving, reduce power to 25%, raise the hook, and release the brakes. Your aircraft will begin moving. Keep power at 25% or lower for taxiing around the deck. Turn right and taxi toward the forward elevator. When you're clear of the runway, cut engine and reapply brakes.

Additionally, any time you come to a complete stop on the carrier, your aircraft is automatically refueled. If you look toward the forward catapults, you'll see the cat officer signalling you. If you taxi forward, obeying his signals, you can reconnect to catapult 1 and launch again. This is another effective way of practicing landings.

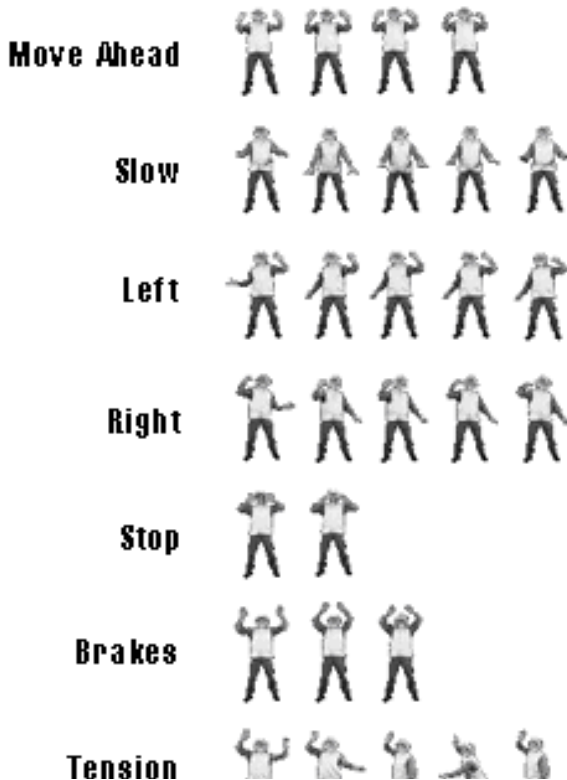

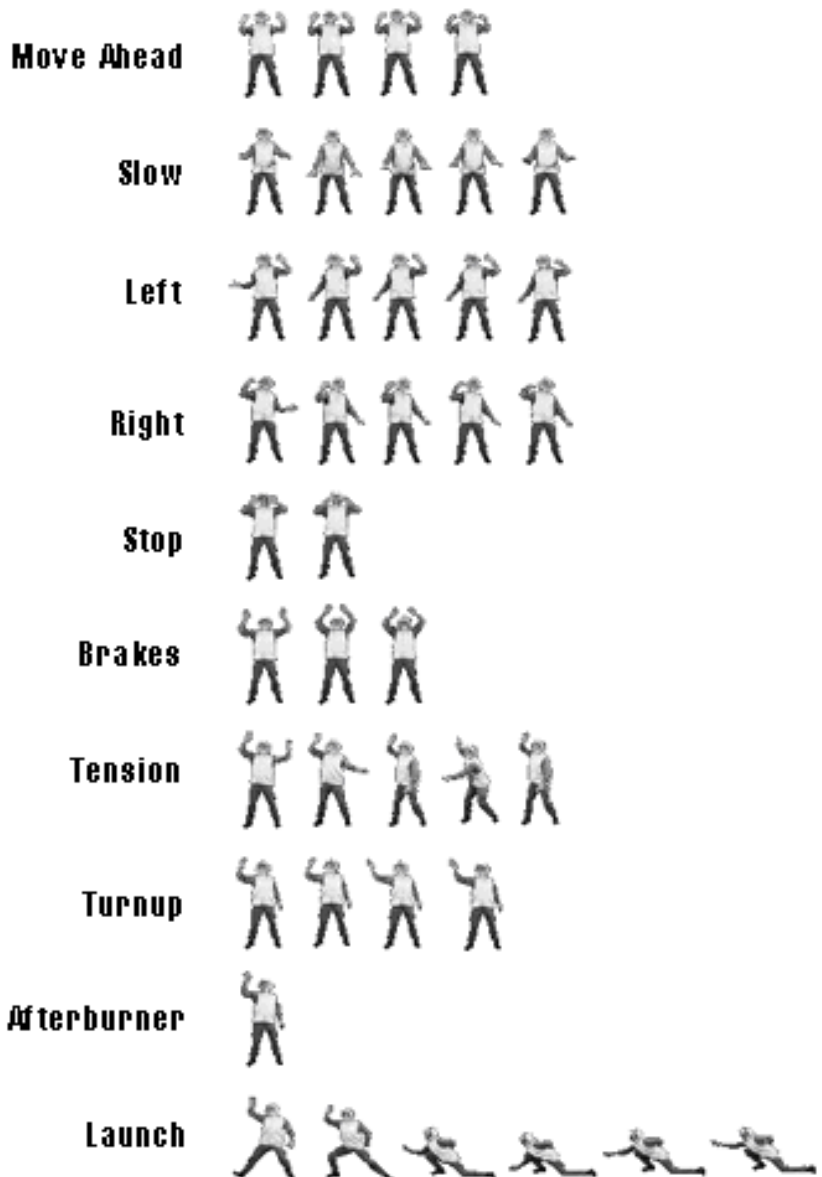

Stalls

A stall occurs when AOA exceeds maximum allowable levels and a smooth airflow over the wings is disrupted. Lift evaporates and the airplane falls toward the Earth. Knowing how to get out of a stall is critical.

First Warning: Buffet and Tickle

As a stall approaches and the airflow over the wings roughen, the plane begins to vibrate, with severity increasing as the airflow worsens. The point where the vibrations or buffet begins is called the *tickle*. Pilots with a light touch can feel the tickle and realize they've reached maximum performance without looking at the instrumentation or actually entering a stall.

Second Warning: Stall Horn

If you do not take action to increase airflow, usually by relaxing G-load and

reducing drag, the disruption and buffeting worsens. If possible, try to increase speed. Fighter aircraft are equipped with a warning called a stall horn which makes a loud, easily distinguishable wail alerting you to the potential stall.

When the Stall Occurs

If you still take no corrective action and a stall occurs, the aircraft begins to fall. If in a turn, the aircraft remains banked, but stops turning and moves in a straight line tangent to the original turn circle. This is called departing controlled flight, or *departure*.

Stall Recovery

Airflow must be re-established over the wings to end the stall, which usually means increasing the aircraft's speed. Engaging afterburner in high-thrust aircraft, such as the F/A-18, sometimes provides sufficient boost. Most aircraft, though, cannot produce enough thrust, even in afterburner, to simply blast their way out of a stall.

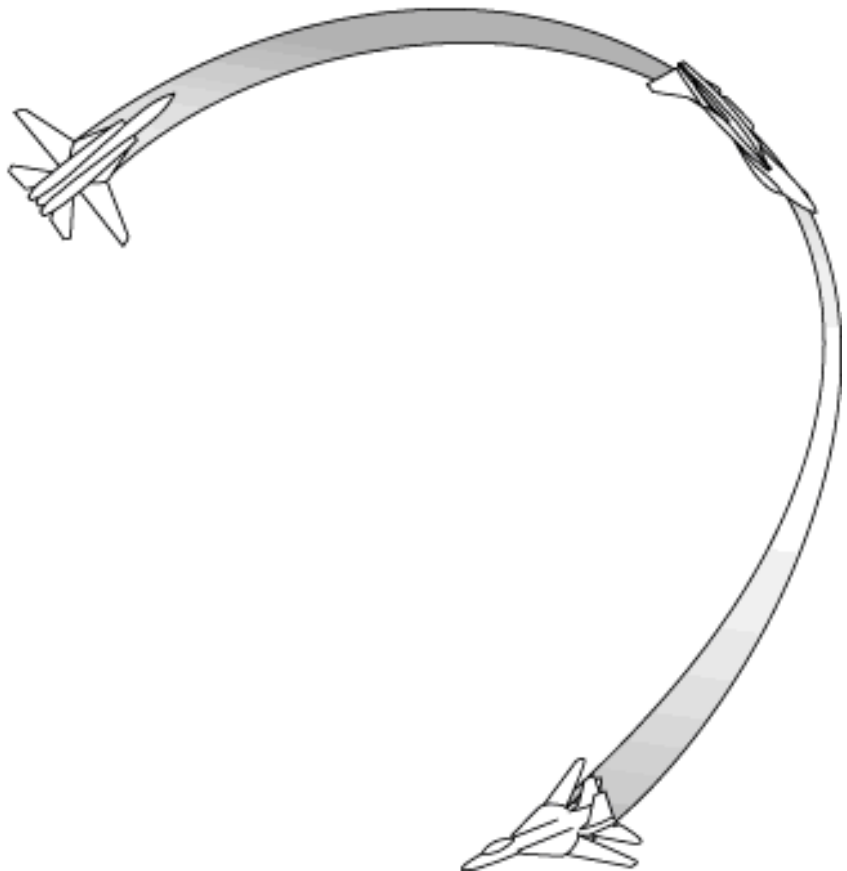

Pointing the nose down quickly adds airspeed and helps re-establish smooth airflow. Of course, your airplane is dropping, so it's critical that you have enough altitude available. A stall at low altitude is often fatal. Also, aircraft control decreases as the stall worsens since there isn't enough airflow over the control surfaces. If you wait too long to begin stall recovery, you may find the aircraft uncontrollable. In that event, you're simply along for the ride and waiting until the aircraft begins to recover on its own. Again, at low altitude, you may not have enough time to wait. Keep the following guidelines in mind:

1. Attempt stall recovery as soon as possible. The longer you wallow uncontrolled around the sky the greater the chance someone will shoot you or you will crash.
2. Always monitor airspeed and AOA instruments. Don't let speed drop below stall speed or AOA exceed maximum.
3. Pay attention to stall buffet. If the aircraft buffets, a stall is imminent.
4. Avoid stalls at low altitude. Devote special attention to avoiding stalls near the floor. Stall recovery often requires altitude. If there isn't enough room to recover, you could buy the farm.

Spins

Spins occur when one wing loses significantly more lift than the other. The wing drops, pulling the aircraft into a rotating, spiral dive. As long as the rotation continues, most control inputs are useless, and some may even aggravate the spin.

Spins were deadly killers during the early days of aviation, before pioneer pilots discovered spin recovery procedures. Some historians estimate more World War I pilots died from spinning and crashing their aircraft than from combat with the enemy. In *U.S. Navy Fighters*, spins only occur if you use the rudder in the direction of the wing that's dropping. Since rudder control is automatically coordinated in the game, you will only encounter spins while manually controlling rudders.

Some of the aircraft you can fly enter spins easily. Others are easier to recover. Note that the F-22, with computer flight controls, will never go into a spin.

Aircraft	Spin Entry	Spin Recovery
F-104*	Easy	Hard
A-7	Easy	Easy
F-14	Easy	Hard
F/A-18	Easy	Easy
Su-33	Hard	Easy
F-22	Impossible	Irrelevant

- The F-104 can enter an unrecoverable flat spin if you keep feeding rudder into the spin. Your only option in an unrecoverable spin is to eject.

Spin Recovery

Once understood, spin recovery is relatively easy, but requires prompt action. A spin may consume several thousand feet of altitude on each revolution, and spin recovery may require several revolutions. Spins at low altitude, therefore, are extremely dangerous. Keep the following guidelines in mind:

1. Neutralize lateral stick. Using the ailerons at this point often aggravates

the spin — center the joystick.

2. Apply full opposite rudder. A message on the HUD will indicate which rudder to apply.
3. Apply forward stick. Push the stick forward to keep the nose down.
4. Maintain control inputs until rotation stops. Keep the controls in this position until the aircraft stops rotating. You will generally find yourself nose-low at low speed and presenting a perfect target for any nearby bandits. Gently pull out of the dive, apply full power, and return to normal flight.
5. Don't panic. If you've done all of the above the aircraft is unwilling to recover, keep your head about you and go through the procedure again. You might also try increasing your throttle in addition to the above.

Chapter 5

FUNDAMENTALS OF AIR COMBAT

Air combat requires locating, targeting, and attacking the enemy while defending yourself against counterattack.

Terminology

Contact	An unidentified object detected by any type of sensor.
Bogey	Same as contact.
Bandit	A confirmed hostile contact.
Target	A targeted contact — not necessarily identified, but being tracked by onboard sensors.

Detection

Detecting the enemy first gives you the initiative, allowing you to gain advantages in altitude, speed, and relative position. In World War I, this consisted of visually scanning the skies. Good eyesight counted for a lot in the early days of air warfare. This remained true in World War II, though radio communications, formation flying, and radar also played important roles. In modern air warfare, detection has become a matter of searching a radar scope as well as visually scanning the sky. In addition, many modern fighters are now equipped not only with radar but infrared sensors, too.

Active Radar

Radar emits bursts of electromagnetic energy into the air. When the waves of energy strike an object, part of the wave is reflected back to the transmitter. Based on the strength of the returning wave, how long it took to return, and its frequency shift, the radar system can determine the object's range, altitude, bearing, and speed.

Active radar allows you to detect and target enemy aircraft at far beyond visual range. Maximum search range is limited only by the size of the radar in your airplane. The only drawback to active radar is that enemies — both on the ground and in the air — can easily detect your radar emissions on their Radar Warning Receivers (see below).

Infrared (IR) Systems

In addition to active radar, some aircraft also carry infrared (IR) sensor systems. The IR-sensor looks for heat generated by other targets. The IR system is passive — it doesn't emit energy, it just looks for objects that are "hotter" than the rest of the environment. It can be used freely in combat because computer enemies never know when they're being tracked by IR-sensors.

With the exception of the F-14B and Su-33, all of the airplanes in *U.S. Navy*

Fighters can be fitted with a FLIR (Forward Looking Infrared) pod which attaches to one of the available hardpoints. The FLIR pod provides you with IR-sensing capabilities, allowing you to target objects like tanks and ground vehicles from beyond visual range. The Su-33 does not require a FLIR pod because it has a built-in IR-sensing system.

IR-sensors are limited in that they have a significantly shorter search range than active radar. In addition, cloudy and foggy weather can reduce IR-sensing effectiveness.

Radar Warning Receiver

Active radar can be detected by anyone within range with a Radar Warning Receiver (RWR). An RWR is a passive device — it doesn't emit energy, it just detects radar emissions from aircraft, ground units, and ships.

All radar emissions — friendly or enemy, in the air or on the ground — appear on your RWR. Likewise, when you use active radar to search for bandits, your radar emissions appear on enemy RWRs. You should judiciously limit active radar use when the mission calls for stealth or surprise.

Detection & Weather

Sensor performance varies with atmospheric effects. Weather can radically increase or reduce sensor performance. The table shows how the range for each sensor type is modified for each weather type. The numbers are percentages of the respective sensors' maximum effective range. For example, night reduces visual sensors to 25% of their normal range while extending IR performance to 125% of normal.

Weather	Visual	Laser	Infra-red	Active Radar
Night	25%	100%	125%	100%
Day	100%	100%	100%	100%
Twilight	75%	100%	100%	100%
Haze	75%	100%	100%	100%
Clouds	10%	50%	10%	75%
Fog	25%	50%	10%	100%

Targeting

There are several ways to target an object in *U.S. Navy Fighters*. Personal preference and the task at hand should be your guide to which means you use. Note that all targeting commands assume some kind of detection device — either the object is in visual range directly ahead, or you've turned on your active radar, IR-sensor, or HARM warhead seeker.

Targeting Aircraft

Activation	Description
Enter	When a target is directly in front of you, you can press

Enter. This locks the next visible object, from left to right.

Apostrophe (') In the normal forward view you can press **apostrophe (')** to lock the visible object closest to the center of the screen.

T or Shift-T When the Radar Window is active, you can press **T** or **Shift-T** to step through each target visible on the Radar Window. These commands also apply to the Radar Window in IR or HARM mode (see *Radar Window* in *Chapter 2: Cockpit Familiarization*). Note that if several targets are at long range, they may appear as a single target in the Radar Window — you may only be able to target one of them.

Click on Radar Window You can lock on a target by moving the mouse cursor to the Radar Window and clicking on a contact.

Click on Visible Target You can lock on a target visible in your normal forward view by moving the mouse cursor onto it and clicking.

Targeting Ground Objects

The pulse-doppler radar systems on most airplanes are designed to accurately track fast-moving objects such as other aircraft. These radar are incapable of detecting small, slow-moving ground targets like tanks and vehicles.

To target a ground object, you must be carrying a FLIR (Forward-Looking Infrared) pod. The FLIR pod lets you target objects in IR mode (see *Radar Window* in *Chapter 2: Cockpit Familiarization*). Note that the Su-33 has a built-in IR-sensor and does not require a FLIR pod.

If you don't have a FLIR pod, you can still visually target a ground object. When the object appears in your normal forward view, press **Enter** or **apostrophe (')** to lock the target.

The Radar Window in HARM mode can also be used to target ground targets employing active radar. Your airplane must be carrying HARM missiles in order to target in HARM mode (see *Radar Window* in *Chapter 2: Cockpit Familiarization*).

Identification Friend or Foe (IFF)

Missiles extend combat to beyond visual range (BVR). In a BVR environment, identifying targets as friendly or enemy is understandably difficult, especially if allied countries fly the same aircraft as your enemies. To overcome this problem, air forces typically outfit their aircraft with IFF (Identification Friend or Foe) transmitters. These devices allow the pilot to transmit an electronic code to a targeted aircraft. If the targeted aircraft's IFF box answers the code, the pilot knows that he's targeted a friendly aircraft.

In *U.S. Navy Fighters*, pressing **U** sends an IFF transmission to a targeted aircraft. If the target aircraft can decipher the transmission, it responds with a similar transmission informing you it is friendly. However, if you do not receive a reply, you do not necessarily know that the target is hostile. The target aircraft's transponder could be damaged, or it could be a civilian passenger jet

not equipped with a military transponder. An “UNKNOWN” reply does not necessarily mean the target is hostile.



Note: The transmitter has a range of 100 nm — if the target is beyond that range, you’ll still receive an “UNKNOWN” message.

Attacking

Air-to-Air Missiles

Air-to-air missiles extend air combat beyond the limits of gun range. Although effective weapons, air-to-air missiles are not the “one-shot, one-kill” devices they are often billed as. Used improperly, air-to-air missiles perform dismally. Air combat success demands a thorough understanding of the weapons at hand.

Semi-Active Radar-Guided

Semi-active radar-homing (SARH) missiles use emissions from your airplane’s radar system to home in on targets. With no radar of their own, these missiles must rely completely on the launching aircraft to maintain a lock on the target. As long as the aircraft “paints” the target with radar, the missile can maneuver toward its prey. If the targeting aircraft breaks its lock — even momentarily — the missile may lose its lock and “go ballistic.”

SARH missiles can be launched at medium ranges (usually 15 - 20 nm) but are very poor in the short range. They also don’t typically work well when fired from above the target, as radar reflected from the ground confuses the missile. The most famous SARH missile — the AIM-7 Sparrow — is notoriously inaccurate, especially when pointed at the ground.

When attacking with a SARH missile, listen for the high-pitched tone emitted by your onboard weapons computer — when tone is good and strong, the missile is locked onto its target.

For comparisons of various semi-active radar missiles, see [Chapter 8: Technical Data](#).

Active Radar-Guided Missiles

Active radar-guided missiles like the AIM-54 Phoenix and AIM-120 AMRAAM have their own onboard radar which they use to track targets. Upon launch, the missile’s guidance system receives coordinates from the aircraft’s weapon system. The missile flies to the designated point and activates its radar, which it then uses to home in on the target. Since the missile guides itself, the launching aircraft can break its target lock any time after firing. For this reason, active radar missiles are known as “fire-and-forget” weapons.

For comparisons of various active radar missiles, see [Chapter 8: Technical Data](#).

IR-Homing Missiles

IR-homing (heat-seeking) missiles home in on the heat generated by the target. Heat-seeking missiles do not require a radar lock on the target before launch or during flight, but their onboard seeker must be tracking the target when you fire. Their “lock status” is best communicated through an audible “growling” sound. The louder the growl, the better the lock. Compared to radar-guided weapons, heat-seeking missiles have fairly short ranges, usually

between 3 - 10 nm.

All heat-seeking missiles have a tendency to be confused by the sun and may stray off toward it. As a general rule, never fire IR-homers when facing the sun. In addition, clouds and fog reduce an IR-seeker's effective range to 10% of normal.

IR-homing missiles are most accurate when fired from behind a target. Early heat-seeking missiles like the AIM-9B are *only* effective from the target's rear quarter, where the seeker has a clear view of the aircraft's exhaust. The more modern AIM-9M can track targets from any angle, but still work best when behind the target.

Also note that newer heat-seeking missiles have deadlier warheads than their older counterparts. The AIM-9M's annular blast-fragmentation (ABF) warhead is significantly more effective than warheads used in older missiles.

For comparisons of various IR-homing missiles, see [Chapter 8: Technical Data](#).

Launch Considerations

One thing is always true regarding missiles: they're fickle creatures prone to failure if not handled perfectly. When fired outside of specified parameters, they almost always miss. When fired within design launch parameters they sometimes miss anyway. The belief that missiles have reduced air combat to a long-ranged, guaranteed-kill affair is pure myth. The following restrictions apply to missile combat.

Maneuvering

The rail or hardpoint the missile mounts on generally has G load restrictions. Some missiles can be fired from rails under as much as 7g, others only at 5g or less. Hard maneuvering onto a bandit's six does little good if you can't fire the missile because you're pulling too many G's. If you pull G above the launch maximum you will lose all lock indicators.

Launch Parameters

The closer to maximum range the missile must fly, the greater chance it will miss. The AIM-54 Phoenix is hailed as 100 nm-ranged missile, but tactical doctrine almost always holds fire until within 80 nm of large targets or 60 nm of fighter-sized targets. Why? Because missile engines do not burn for the entire missile flight. The motor engages initially and rapidly accelerates the missile to top speed. While the engine is burning the missile has incredible thrust and is extremely maneuverable. Once the engine runs out of fuel — usually within 5 - 10 seconds after launch — the missile glides the rest of the way to the target, losing speed as it glides. As speed decays, so does maneuverability. The AIM-54 can reasonably reach a target at 100 nm, but has virtually no maneuverability at that range. If the target isn't obligingly holding a steady flight profile, the missile will almost certainly miss.

Most missiles have minimum launch ranges, too. The missile requires room to get up to speed, and the seeker needs a good lock on the target before it starts maneuvering. Since the probability of a direct hit on a maneuvering target is unlikely, missiles are designed to cause a wide field of damage. Some missiles release a giant, expanding ring of iron bars, while others release hundreds of smaller metal fragments. The larger the area covered by these warhead, the greater the probability of a kill. Most missiles have

minimum launch ranges to ensure that the launcher doesn't inadvertently harm himself.

In general, you want to launch within the missile's optimal launch parameters. These can be gauged by watching the Hit Probability Indicator on your HUD.

Target Aspect Angle

Target aspect-angle plays a large roll in missile effectiveness. Low-aspect shots, or those fired from directly behind the target, have a greater chance of success than those from high-aspect shots fired at the target's side. In general, the missile must pull at least 7 times the G-load as the target. If the target is pulling 9g, the missile will need to pull as much as 63g.

Target aspect also impacts missile range. If the target is moving toward the launching airplane, the missile has less distance to travel. The missile can be fired sooner, therefore, because the target will "fly into" it. This effectively extends the missile's maximum range. Conversely, if the target is moving away, the missile's effective range is reduced. The missile must be fired from a closer range to ensure it has enough energy to travel the additional distance covered by the target.

In general, firing missiles from shorter ranges and from directly behind the target results in higher hit rates. Firing from long range at maneuvering targets results in lower hit rates.

Air-to-Ground Weapons

Air-to-ground weapons come in two basic varieties; guided and unguided. Guided weapons, such as Maverick missiles and laser-guided bombs, have seekers and the ability to modify their path while flying to the target. Unguided weapons, called *iron bombs*, fall along a predictable trajectory. Both types require a different delivery approach.

Air To-Ground Missiles

Air-to-ground missiles, such as the IR-homing AGM-65 Maverick or the active radar-guided AGM-84E SLAM, are long-range "standoff" weapons. Once fired, these weapons do not require the launching aircraft to guide them. As such, they are "fire-and-forget" weapons — you can launch them and immediately turn toward a new target.

Anti-Radiation Missiles

The AGM-88 HARM (Hightspeed Anti-Radiation Missile) detects radar emissions and homes in on them. HARMs are only useful against objects employing active radar, such as SAM sites. If the target shuts off its radar for any reason, the missile may lose its lock and fly off course.

The HARM is another "fire-and-forget" weapon — once launched, the missile requires no guidance from the aircraft.

Iron Bombs

Despite technological advances, most militaries still rely on inexpensive, low-tech general purpose "iron bombs" for destroying enemy targets.

Bombs rely on gravity to pull them down to the target. Once released, they follow a predictable path to the Earth based on the aircraft's pitch, speed and altitude. The higher the aircraft is, the longer the bomb's range.

Accurately dropping bombs is easier said than done. If your airplane is moving wildly upon release, the bombs will fall likewise. It's important that you hold the aircraft stable while dropping bombs. Iron bombs are further limited by a short range of 1 - 2 nm. Beyond this range the chance of hitting the intended target is almost zero.

Laser-Guided Bombs

A laser-guided bomb is an iron bomb fitted with a seeker and movable canards, which help guide the weapon to the target. The bombing sequence works like this. The aircraft illuminates the target with a "laser-designator" carried on one of the aircraft's hardpoints. Once the bomb is dropped, its seeker homes in on the laser reflection and provides direction to the movable canards. The canards modify the bomb's glide path to some extent, resulting in more accurate hits than conventional iron bombs.

In *U.S. Navy Fighters*, both NATO and Russian laser-guided bombs require the Pave Spike laser designator for target illumination. You must maintain a lock on the target until the bomb has hit — if you suddenly target another object, the bomb will fall blindly to the ground and will most likely miss.

Guns

Once thought out-dated by the air-to-air missiles, the gun has proven itself a staple of air combat.

Guns are generally effective only under 2 nm. A single burst of gunfire generally won't kill an aircraft. It may cripple it, but unless you're lucky enough to wound the pilot, a single hit probably won't remove the enemy aircraft from the fight.

Defensive Systems

Attacking the enemy is only half the job — surviving the mission is the other half. Your aircraft carries various defensive systems designed to protect you and your airplane.

Warning Tones

Two audible tones support the RWR: one for radar-guided missiles, and another for IR-guided missiles. A slow-pulsing tone indicates an enemy seeker is tracking your aircraft. A fast-pulsing tone indicates an inbound missile is tracking your aircraft. Both of these tones are lower-pitched than the lock tone indicating one of *your* missiles is locked on to a target and ready to be fired.

Chaff

Chaff is the standard defense against radar-guided missiles. Chaff consists of spools of material designed to reflect enemy radar signals. Hopefully, the material will reflect more radar energy than your aircraft, thus providing a "brighter" target for the missile's seeker. With careful use, chaff will attract inbound missiles away from your aircraft.

Flares

Flares are the heat-seeking equivalent to chaff. Flares create hot, bright fireballs designed to attract heat-seeking missiles. Older heat-seeking missiles are easily deceived by flares while newer designs are quite resistant.

Jamming

Electronic Counter Measures, or ECM, attempts to deceive enemy radar by emitting large amounts of electromagnetic energy. Also called “jamming,” these bursts of energy appear as “fake” radar returns to the radar source. The radar source sees not just the “real” radar return, but all the “fake” ones generated by the jammer. The radar cannot distinguish the real one from the fake ones, so it displays them all on the radar screen. Because of the fake returns, the radar knows *something* is out there, and even which direction it’s at, but cannot determine the target’s precise location. Therefore, jamming announces your presence to the enemy, but hides your exact position from them. RWRs also detect jamming signals; therefore, never use jamming unless the enemy is using active radar.

Using Defensive Systems

Missiles are very maneuverable but have limits. Remaining outside of the enemy missile’s range is by far the best defense. Failing that, using ECM at moderate to long ranges may jam enemy radar and prevent enemies from firing at you. ECM has no effect against heat-seeking missiles and unpredictable results against radar-homing missiles fired at close range. Under these conditions you must rely on maneuvering and chaff or flares to defeat the missile.

Beating Radar-Guided Missiles

Normally, turn toward the missile such that the missile is always facing your side. This forces the missile to continually turn to track you. Keep the missile off your wing using low G turns as the missile closes. When the missile closes within 2,000 feet, rapidly release 3 or 4 chaff and execute a maximum G break turn toward the missile. Ideally, the missile will momentarily target the chaff cloud while the high-G turn moves you outside the missile’s field of view. When the missile loses lock it stops pointing at you. Using alternate views, such as the F5 window, to watch the missile’s smoke trail to determine if it’s still tracking you or not. Remember that your warning horn will sound at a faster-pace as long as the missile is tracking you.

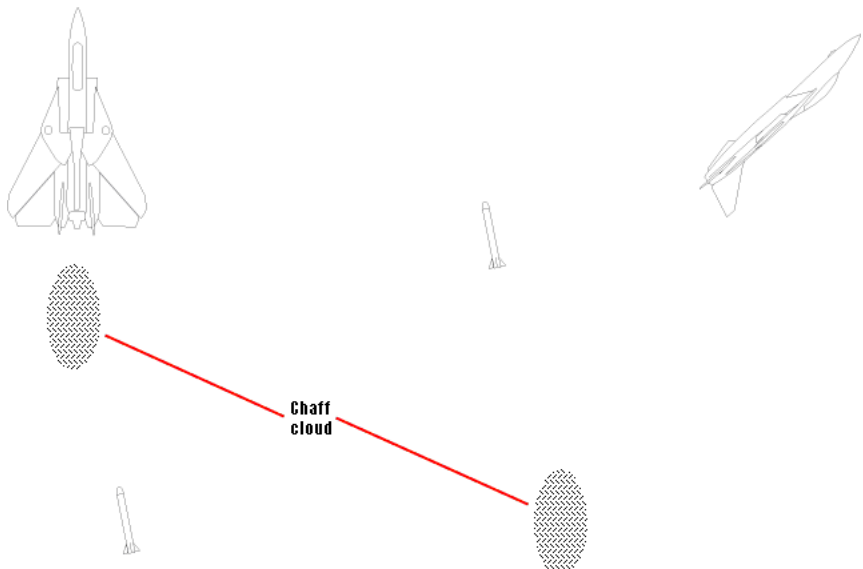

Beating Heat-Seeking Missiles

The same procedure for radar-guided missiles holds for heat-seeking missiles substituting flares for chaff. Older heat-seeking missiles require a clear view of your aircraft's exhaust. Besides out-maneuvering the missile, the break turn may hide your exhaust from the missile's seeker. Turning toward the sun and turning off your afterburners may also help. With any luck, the flares or the sun will entice the heat-seeker away from your aircraft.

Guns Defenses

Jinking, or making numerous, unpredictable, erratic flight movements, is the standard guns defense. The key to evading enemy gunfire is being unpredictable. The enemy may be firing anywhere from 1/2 to 2 miles away and must aim his bullets at where he thinks you'll be by the time the bullets get there. Changing course often gives your opponent ample room to make a mistake.

Signatures

Every object has a set of "signatures" corresponding to each sensor type. For example, an object's "radar signature" indicates how easily it is detected by radar. Your aircraft's configuration can modify signature values. For example, using afterburner increases your IR signature to 200%, making you twice as detectable as normal. Carrying external stores increases your radar signature by 33%, making you one-third more detectable than a "clean" aircraft. Lowering gear likewise increases radar signature by 25%.

Radar jamming reduces the chances of being tracked by radar sources but drastically increases your chances of being detected. Pointing your aircraft at a sensor greatly reduces the corresponding signature since an aircraft appears smallest when viewed from directly ahead.

Taking Hits: The Effects of Damage

With luck your airplane will never see damage. In the event that you take some hits, though, it's good to know what's critical and what's not.

Each aircraft has multiple subsystems, such as propulsion and control surfaces, and each subsystem has multiple items, such as fuel flow, elevators, etc.

Damaged control surfaces make the aircraft difficult to fly or possibly even uncontrollable. The autopilot cannot be used with damaged control surfaces. Damaged elevators reduce pitch control, damaged ailerons reduce roll control, damaged rudder usually causes the aircraft to yaw one way or the other. Some types of damage cause the aircraft to porpoise or jolt in random directions. If the hit damages the airframe, pulling high G loads will likely destroy it.

Several types of propulsion damage ultimately lead to a catastrophic failure. Damage to the oil systems causes engine overheating unless the throttle is kept low. Even then aircraft may eventually overheat. Compressor damage risks catastrophic engine failure when the engine is above 25% throttle. Damaged tail cones limit afterburner use.

Generally, when the engine takes damage, reduce power. Engine explosion may be inevitable based on the extent of damage, but reducing power will

always delay it. If intuition tells you the engine is about to explode, bail out.

You, the pilot, may also take damage from explosions, shrapnel, or fire. Each wound requires medical attention or you will die. You may have as much as 15 minutes or so to return to base after the first wound, but subsequent wounds greatly reduce that time.

Wingman Commands

Lone wolf cowboy tactics will leave you riding the silk elevator down to the ocean every time. Aircraft work in groups, usually pairs, for mutual support and protection. Your wingman is there to protect you and you're there to protect him.

Your wingman executes command based on formation scope. There are two formation scopes: Loose and Medium.

Loose	Under Loose control, your wingman will break from your formation when an enemy is detected or if an incoming missile is detected. Once he moves out of formation to attack, he will continue to search for and engage enemies until you tell him to disengage.
Medium	Under Medium control, your wingman remains in formation unless you direct him to attack a target, though he will break in order to avoid an incoming missile.

There are 19 different wingman commands available:

When You Press	Command Name	The Wingman Executes
Alt - 1	Fly straight and level	Wingman rolls out and flies straight and level
Alt - 2	Break left	Wingman breaks left
Alt - 3	Break right	Wingman breaks right
Alt - 4	Break low	Wingman breaks low
Alt - 5	Break high	Wingman breaks high
Alt - 6	Approach left	
Alt - 7	Approach right	
Alt - 8	Approach low	
Alt - 9	Approach high	
Alt - B	Bug Out	Order wingman to return to base

Alt - C	Toggle control scope	Selects control scope loose or medium
Alt - T	Set formation type	Selects formation type
Alt - H	Set formation horizontal spacing	Specifies horizontal distance between you and wingman
Alt - V	Set formation vertical spacing	Specifies vertical spacing between you and wingman
Alt - E	Engage my target	Orders wingman to break from formation and engage whatever target you currently have locked
Alt - W	Engage target class	Order wingman to engage all targets of the same type as the target you currently have locked
Alt - R	Engage from formation	Orders wingman to engage your target but remain in formation with you (ie, use a long-ranged missile like the AIM-54)
Alt - P	Protect me	Orders wingman to attack bandits threatening you.
Alt -D	Disengage	Orders wingman to break off attack and reform on your wing.

Chapter 6

ADVANCED COMBAT TECHNIQUES

Air combat is a complex, dynamic environment. To succeed, you must be thoroughly prepared before engaging the enemy. The following are theoretical principles that have real application in *U.S. Navy Fighters*. Understand them and you'll be well on your way to becoming an ace.

Geometry

A few geometry concepts are needed for a complete discussion of air combat.

Angle Off Tail

Angle off tail (AOT) measures the angle between your flight path and that of the target. At low AOT, you are either at the target's 6 o'clock as it moves away from you, or at its 12 o'clock as it moves toward you. In either case, weapons need only fly a straight line into the target. Almost all weapons perform better when fired from low AOT.

As AOT increases, the target is moving away from your flight path. Missiles have to turn more to track the target and gun shots must lead the target, allowing the target to "fly to" the bullets. During a sustained engagement your goal is to reduce AOT as much as possible before firing.

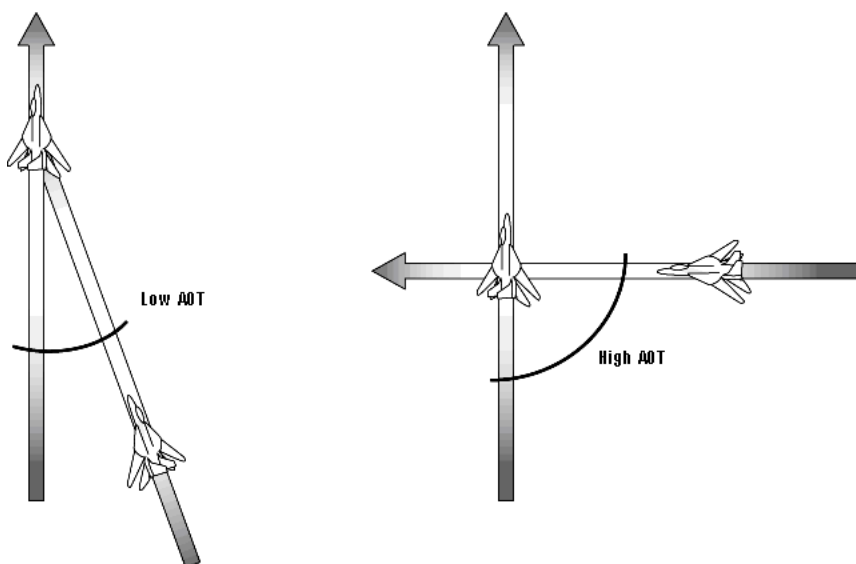

Aspect Angle

Aspect angle indicates which aspect of the target is facing you. Think of it as a numerical way of expressing which part of the target you're looking at.

From the diagram, you can see that a "left 90 degree" aspect angle on the target means that if you looked at the target — regardless of where it is around your airplane — you would see its left wing. A low aspect angle

(approaching zero) indicates that the target's tail is in view. A high aspect angle (approaching 180) means the target's nose is pointed at you.



Closure Rate

Closure rate is the combat epitome of the old high school math problems about trains leaving Dallas and Kansas City at different times headed for each other. Closure is your aircraft's speed relative to a moving target. If closure is positive you are getting closer to the target; if it's negative the target is getting farther away. The higher the value of the number, the faster the range is changing. A closure of -700 kts means the target is moving away from you very fast while a closure of -70 kts means the target is moving away from you slowly.

Alternatively, visualize closure as the speed you would be flying if your target suddenly became stationary. If you and your target are flying directly at each other both at 450 kts, your closure speed is 900 kts. If you happened to be 900 nm apart, it would take you one hour to pass each other. If the target suddenly froze in mid-air, your aircraft would have to accelerate to 900 kts to arrive at the target in the same length of time.

Closure, therefore, is a good indicator of the target's aspect. When closure is a high positive value, you know he's heading for you. Closure also impacts weapon performance. At a high positive closure rate, the range to the target is rapidly decreasing. A missile doesn't have to fly as far to the target since the target reduces range by flying into the missile. Conversely, if the closure is a high negative value, the target is running away and the missile must fly farther to overtake the target.

Pursuit Curves

When dogfighting, there are three types of pursuit, lead, lag, and pure. Depending on the combat situation, you will find all three necessary

Lead Pursuit

As the name implies, lead pursuit means predicting where the target aircraft will fly next, then leading the target, or pointing your nose ahead of the target. In other words, you point your flight path to cross the target's predicted flight path.

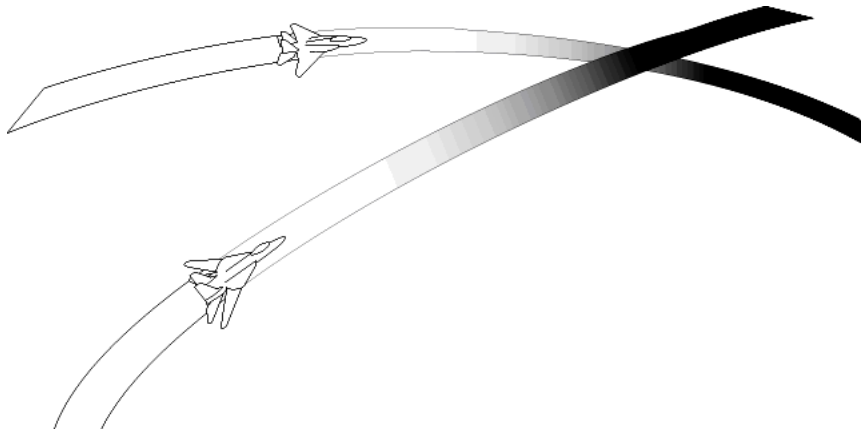

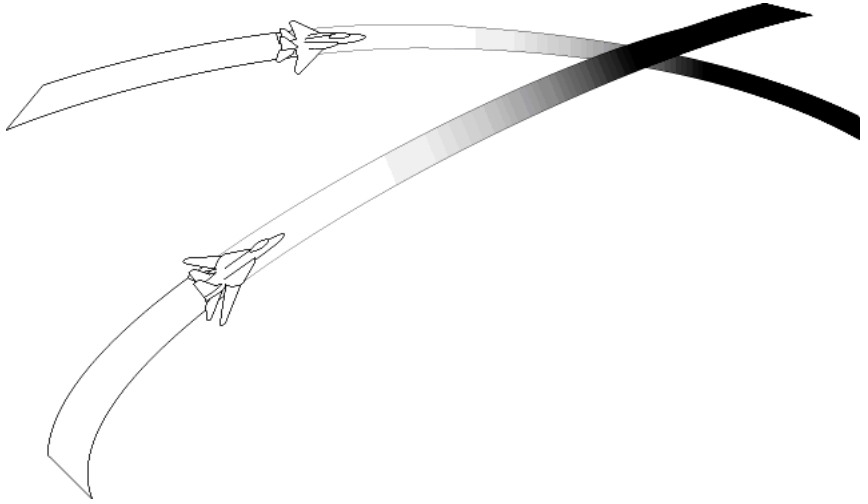

Because you're pointing ahead of the target, lead pursuit increases closure, or the rate at which you approach the target. If you're positioned beyond your weapon's maximum range, lead pursuit will bring you closer to your opponent. Lead pursuit, however, depends upon accurately predicting where the bandit will fly. Pulling your aircraft into lead pursuit causes the target to disappear beneath your aircraft's nose. If the target makes an erratic maneuver, you may be unable to see it. Therefore, as is so often the case in ACM, small, patient, persistent lead pursuit angles that keep the target in sight are the most desirable.

Pure Pursuit

Pure pursuit is a direct chase. You point your aircraft directly at the target and follow its maneuvers. Pure pursuit is generally used when firing weapons. At long ranges, both missiles and guns require some leading, but at close ranges put your nose directly on the target and fire.

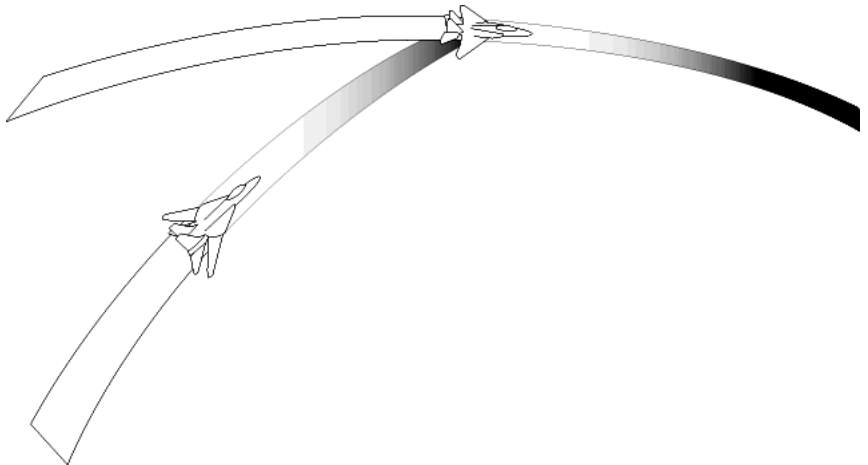

Lag Pursuit

As the name implies, lag pursuit points your flight path behind the target, using turn rate, not turn radius, to follow the enemy. Lag pursuit is a critical combat tactic that requires not only an awareness of the battle, but an awareness of your aircraft's capabilities.



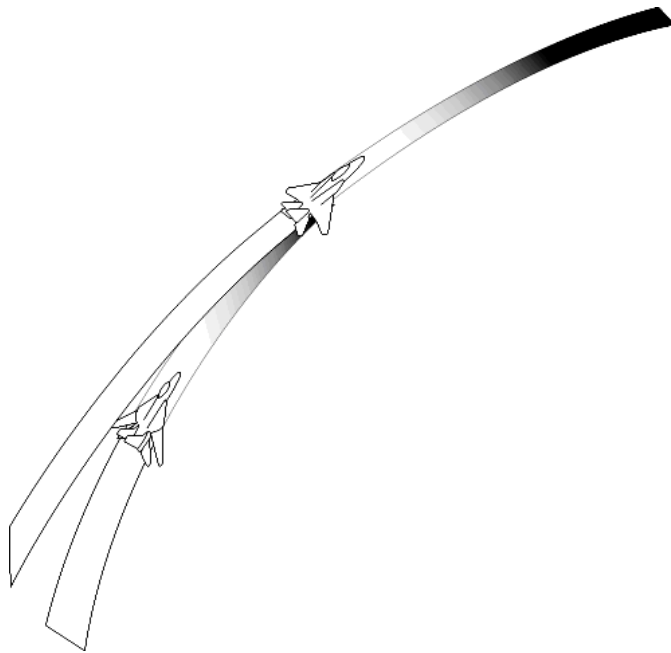

Whereas lead pursuit increases G-loading to tighten turn radius and point ahead of the target, lag pursuit surrenders the turn radius battle and relies on turn rate. For example, comparing the different turn rates and turn radii of a F-18, F-4, and MiG-21 at 36,000 feet at a constant 4g, you can see that the F-18 has a significant edge over both other aircraft using a significantly slower speed.

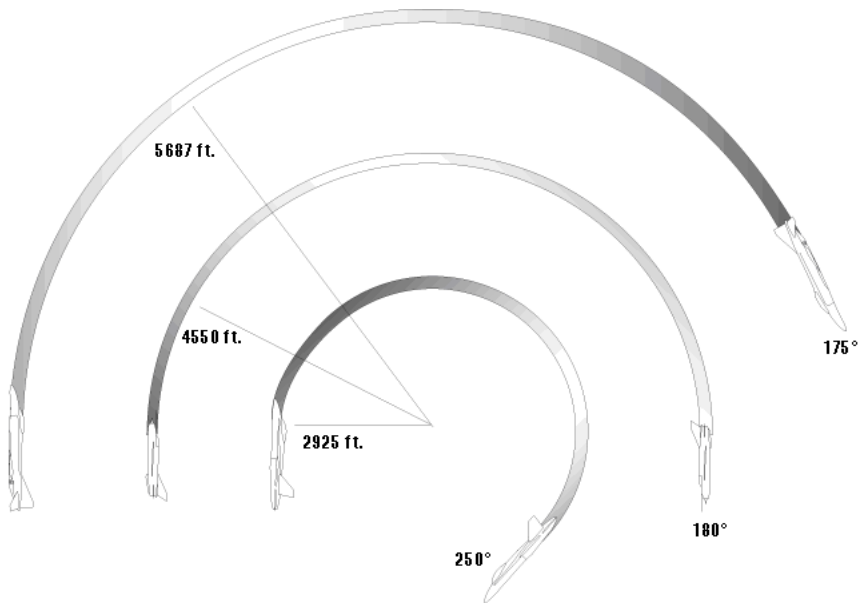

Now imagine a high-speed F-18 with a low speed MiG-21. The Hornet comes screaming in at mach 1.4 towards the MiG moving a mere Mach .5. At this speed, the F-18 has a superior turn rate, but a vastly inferior turn radius. There is no way the Hornet can turn inside the slower adversary.

The maximum amount of G the F-18 can pull under these circumstances is 5.25g for a 9.5j/second turn rate, compared to the MiG-21's 2g for a 6j/second

turn rate. The F-18 can use its turn rate advantage to lag pursue the bandit despite a turn radius disadvantage. The F-18 can relax to approximately 4g and match the MiG-21's turn rate, circumscribing a concentric turn circle outside the MiG-21 without overshooting.

This a perfect lag pursuit opportunity for the F-18, granted the pilot realizes his turn rate is better than his enemy's. If the F-18 tries to match the MiG-21's turn radius by pulling a maximum 5.25g, he will not only overshoot by some 3,000 feet, but will rapidly bleed speed as drag increases, wasting his initial energy advantage. Lag pursuit allows the F-18 to remain in the MiG-21's blind spot (i.e., directly beneath it), avoid overshooting, and effectively conserve its initial energy advantage.

Lag pursuit is easy to execute. Pull back on the stick until the target aircraft is positioned on your HUD only slightly above the flight path indicator, then release pressure on the stick so that it remains stationary at that HUD position.

Energy Management

There are two types of energy in the world, kinetic and potential. Energy, in both its manifestations, is the core of aerial combat. At any given instant, an aircraft possesses some quantity of kinetic energy (measured by its speed) and some quantity of potential energy (measure by its altitude). Energy translates directly into maneuverability. Air Combat Maneuvering, or ACM, is a game of managing energy to maximize maneuverability and defeat the enemy.

Exchanging Energy

Energy types are exchangeable. An aircraft at high altitude and slow speed has lots of potential energy, but little kinetic energy. By diving, the aircraft can convert the altitude into speed, thus increasing kinetic energy. A fast aircraft at low altitude has lots of kinetic energy but little potential energy. The aircraft can convert the kinetic energy back to potential energy by climbing. The aircraft slows down, but its altitude increases, maintaining the aircraft's total energy state. An aircraft at low speed and low altitude has very little total energy. An aircraft with energy has maneuvering options, an aircraft without energy generally becomes a target.

Maneuvering uses energy. Every maneuver you make "burns" kinetic energy. Because you want maximum maneuverability from your aircraft at all times, you must ration your energy use, always maintaining a sufficient supply for whatever maneuver you might execute.

Playing the Energy Management Game

Never waste energy. Don't pull 6g when 2g will suffice. How do you know that lower G loading is acceptable? Watch his nose and remember this simple rule: when his nose isn't pointed at you, he's not a threat.

Obviously, most weapons can be fired from various aspect angles besides directly astern, but by watching his nose you can determine when he's achieving a firing solution. For guns, his nose must be pointed slightly ahead of you due to lead requirements. Even with missiles, his nose must be pointed generally in your direction for a decent shot.

If he's behind you and pulling into a firing solution, you need to extract every ounce of maneuverability from your airframe. If, however, he doesn't have his nose pointed toward you, he cannot shoot at you. Before spending the

maximum G available you have to determine what you'll get in return. If you pull max G now, will you get a shot opportunity? If not, then pulling maximum G is probably a bad idea.

When you're out of energy, you have to get some back. Extending for energy means relaxing the back pressure and rebuilding airspeed. It can mean unloading to 1g and flying straight and level, or it can mean simply unloading from 4g to 3g and slow the energy bleed. Many times, wasting energy at a slower rate is as important as getting more back.

In short, treat energy as money. You can save it, waste it, or spend it foolishly, and once it's gone it's gone forever.

Picking Your Fight

Arguably, the first few seconds of a fight are the most important. With most dogfights lasting less than a minute, whoever grabs the advantage in the first few seconds usually wins. Ideally, you want to start the fight with an advantage, such as directly behind the bandit in his six o'clock low blind spot. Most of the time that's not an option and you find yourself closing head-to-head with the bad guy.

Choosing The Energy Fight

The energy fight basically concedes turning performance to the enemy. The energy fighter keeps his speed extremely high, minimizes lateral separation on the merge, tries to take a shot at the bandit at the merge, then extends in a straight line far beyond the opponent. The energy fighter must maintain enough speed to quickly exceed his opponent's weapon range. This isn't too difficult if the bandit only has guns or heat-seeking missiles. While the bandit executes a high G turn to enter the fight, the energy fighter zooms away in spiralling dive or climb. Eventually, the energy fighter executes a low G turn (to conserve airspeed) and makes another pass at the bandit, in a "hit-and-run" attack.

When executed correctly, the energy fighter remains outside the bandit's weapon envelope nearly the entire fight. The energy fighter chooses when and where he'll engage, always bringing the fight on his terms. Even better, thanks to the speed surplus, the energy fighter can extend and exit the fight almost at will. The energy fight requires discipline, though. One speed-bleeding turn and the energy fight option is gone forever.

Angles Versus Energy

At the merge you have a choice: enter a knife fight and rely on your turn performance to win the day (the angles fight), or use superior energy and hit-and-run tactics (the energy fight). Every fight is different, and an aircraft designed for angles fighting may find itself better suited for an energy fight. How do you decide which to use?

First, estimate your turn performance versus your opponent's. Being at and maintaining your corner speed means squat if the bandit can out-perform your best turn. Second, estimate your energy status. If you enter a fight 200 or 300 kts above your corner speed, don't merely waste all of that energy and decelerate to corner, initiate an energy fight and make use of that power. A well-flown energy fight is difficult to beat, as proven in Vietnam by F-4 pilots flying against MiG-17 and MiG-21 opponents.

Setting Up the Merge

The merge, or meeting the bandit head on, generally leads to one of two types of fights: one-circle or two-circle.

Two-Circle Fights

Two-circle fights, also called nose-to-tail fights, commence when both fighters turn toward each other at the merge. The distance between the fighters, called lateral separation, is turning room both fighters use, that is, part of their turn radius toward the bandit is offset by the lateral separation.

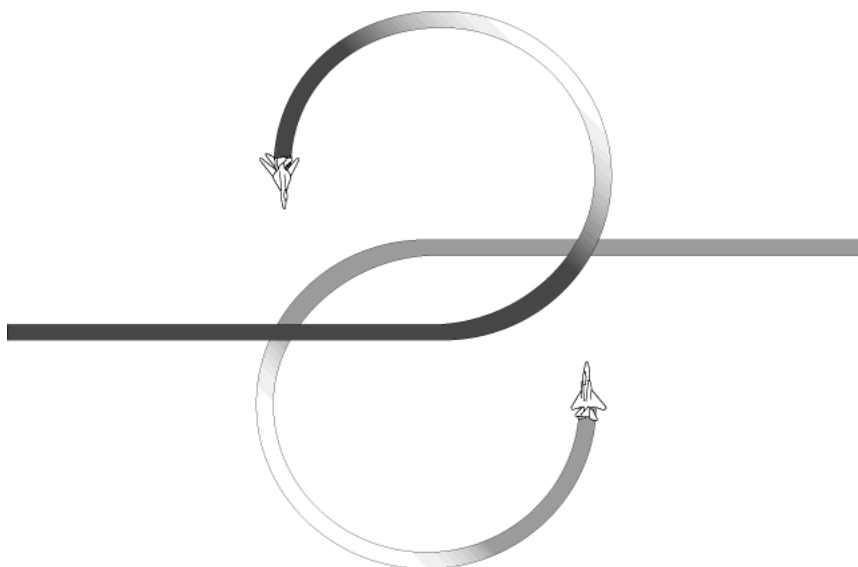

Two-circle fights rely on turn rate more than turn radius. The pilot tries to create enough lateral separation at the merge to account for his turn radius, then relies on a superior turn rate to bring his nose to bear on the bandit faster. Two-circle fights keep the bandit in view at all times and also tend to increase the distance between the aircraft.

Generally, attempt to minimize lateral separation to the distance of your turn radius. If the enemy aircraft has substantially worse turn performance than you, don't give him any extra room to work with, keep lateral separation to the bare minimum you require. If the bandit has significantly better turn performance than you, deny him the chance to use it by coming in at maximum speed with as little lateral separation as possible.

One-Circle Fights

One-circle fights commence when both fighters turn the same direction. One fighter sacrifices any lateral separation, relying on turn radius to out maneuver the enemy. The one-circle fight is generally only used when you have a significant turn radius advantage over the bandit.

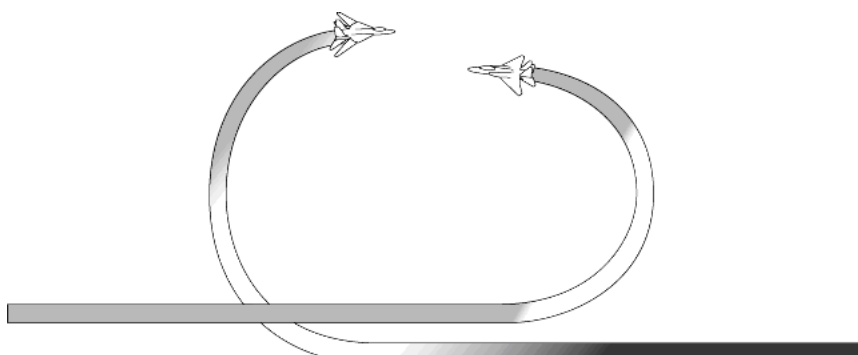

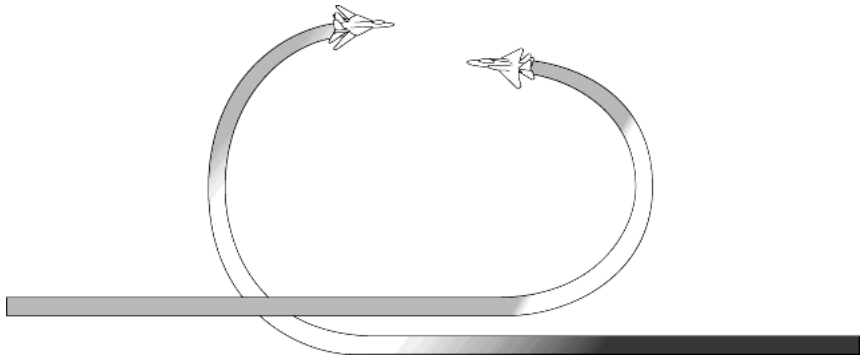

The one-circle fight tends to keep the participants closer together than the two-circle fight. The fighter that chooses to go one-circle and turns away from the bandit must momentarily lose sight as the bandit crosses his tail. In fighters with poor rearward visibility, this loss of visual contact can be devastating. Since the one-circle fighter surrenders the lateral separation to the bandit, he should minimize lateral separation during the merge.

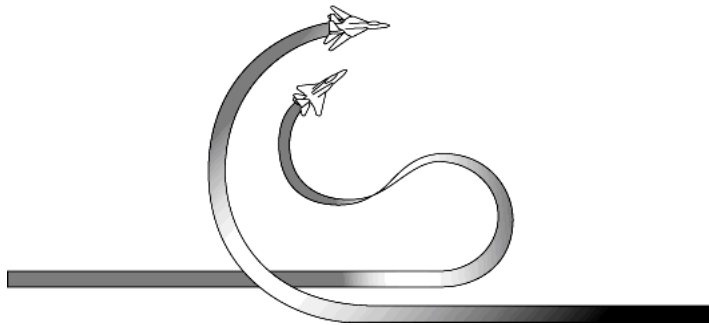

Timing The Initial Turn

Timing the initial turn is critical. Turning too soon or too late surrenders advantage and often proves fatal. Turning too soon pulls you across the bandit's nose, not only giving him a snapshot opportunity but also putting you on the defensive. Turning too late puts you out of position and allows the bandit to gain angles. The perfectly timed turn should deny the bandit any advantages while maximizing your own performance.

Air Combat Maneuvers

Break Turn

The break turn is the most basic of all combat maneuvers designed to increase AOT rapidly when a bandit is preparing to shoot you. It is a high G maneuver utilizing maximum instantaneous turn rate toward the attacker.

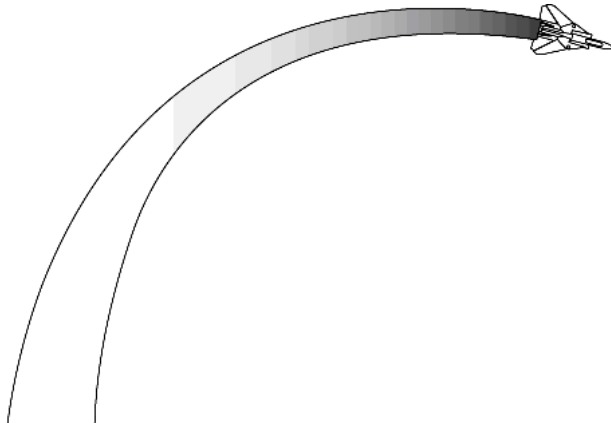

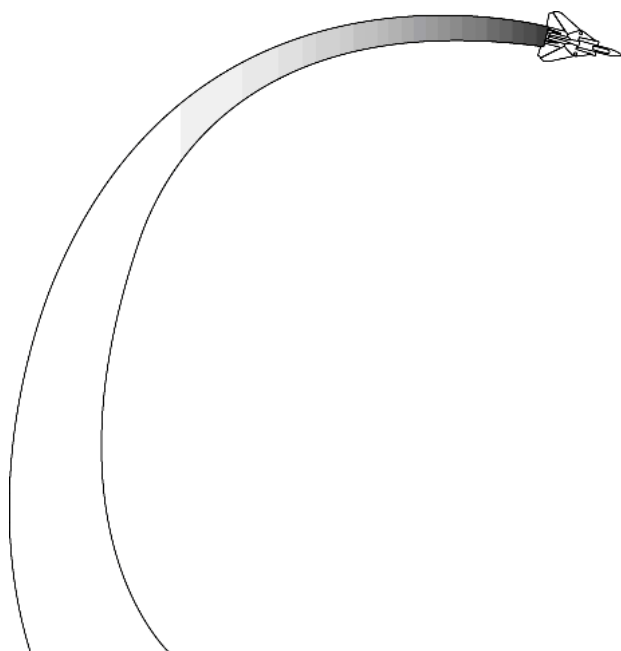

Once you execute a break turn, do something else almost immediately. Sustaining a break turn leaves you as a nice, stable, predictable target waiting to die. Once the break turn has commenced, both you and the target share a common plane in space. Generally, your next maneuver should take you out of this plane and even further away from the target.

High Yo Yo

The high yo yo is the root of all offensive air combat, replacing intelligent maneuvering for “G for brains” high-G tactics. The high yo yo reduces AOT at the cost of increased range between attacker and target.

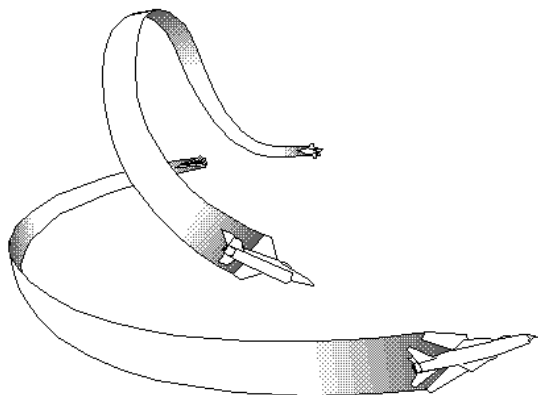

The yo yo begins during a turning fight when you have assumed an aggressive position behind the bandit, but are stuck in lag pursuit and unable to bring your nose to bear. Roll out slightly, maintaining the lag pursuit, then pull the nose up.

Generally, a series of small yo yos that nibble away at the AOT problem work better than one large yo yo. Once committed to a large yo yo, you'll be unable to respond to any sudden changes the bandit may make. Patiently working small yo yos by bringing the nose just above the horizon chips away at your AOT problem and moves you into the target's elbow without pulling super high

G loads.

Low Yo Yo

The low yo yo is the logical opposite of the high yo yo and performs the exact opposite function. Whereas the high yo yo decreases AOT and increases range, the low yo yo increases AOT while decreasing range.

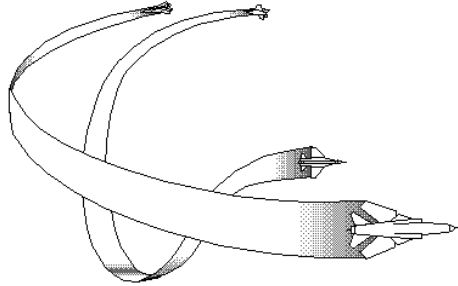

The low yo yo is generally used when you don't have a good shot opportunity, but you're outside your weapon's maximum range. To get closer, you lower your nose below the horizon. Lowering the nose increases speed. Unfortunately, the increased speed almost always results in increased turn radius, forcing you into lag pursuit and increasing AOT. A low yo yo, therefore, almost always requires a following high yo yo to correct the angles problem generated by the increased speed.

The low yo yo is often used in chases where the bandit has superior speed, has leveled its wings, and is trying to run home as you chase it from just outside your weapon's envelope. In this case, you could lower the nose and dive below the target. The increased speed will increase closure, but you must be careful not to dive too steeply. If you dive too far below the target or build up too much speed in the dive, you may still be unable to bring the nose to bear on the target which is now far above you.

Barrel Roll

The barrel derives its name from the flight path the aircraft performs, circumscribing the shape of a barrel in the sky. The barrel roll is more than an airshow stunt, it's an energy management maneuver with both offensive and defensive potential.

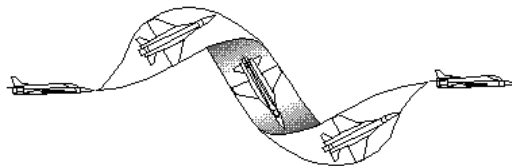

Offensive Barrel Rolls

Offensively, always remember: do anything it takes to prevent an overshoot. Overshooting and flying in front of an enemy are deadly mistakes which will most likely cost you your simulated life. Overshoots are caused by excessive closure which you can't get rid of; you approach the bandit too fast and can't stop in time. The barrel roll is one solution. If you can't reduce speed fast enough by pulling the nose up, then pull back on the stick and execute an aileron roll to the direction opposite of your current turn. The raised nose

reduces speed while the roll out turns you away from the target and prevents an overshoot. Completing the roll leaves you heading in the original course, albeit no longer overtaking the enemy.

Defensive Barrel Rolls

The barrel roll can be used to force the attacker to overshoot while maintaining enough AOT to prevent him from firing at you. Defensive barrel rolls must be carefully timed. Initiate the roll too soon and the bandit will recognize it and follow you through it. Start it too late and the bandit will have already shot you. Perfect timing requires surprising the bandit and denying him sufficient time to react before he overshoots.

Scissors

Ask any combat pilot and he'll tell you the same thing: if you get into a scissors fight, you screwed up.

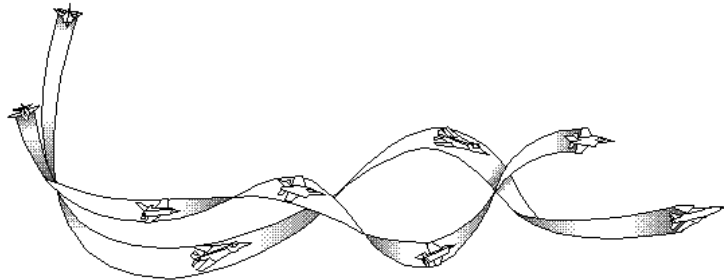

A scissors is a series of reversing turns where each aircraft turn back towards each other, each trying to force the other out in front. A scissors usually begins when the attacker realizes he's going to overshoot. The defender sees the imminent overshoot and reverses his turn back toward the attacker too early, thus resulting in a fairly neutral pass. If you're an attacker, the only way you can get into a scissors duel is by screwing up and overshooting. If you're offensive, scissoring should be the last thing on your mind. If you're defensive, you already screwed up. Reversing into a scissors indicates the attacker also made a mistake, but you compounded your error by reversing too soon and wasting the advantage.

Once in a scissors, there's nothing to do but keep the G high and keep turning into the bandit. Of course, this bleeds speed and energy horrendously. Ideally, the "winner" of a scissors match forces the bandit ahead of him while still having enough energy to bring his nose to bear. More often, one aircraft stalls out and plummets earthward. If the other aircraft has any semblance of energy left it rolls, dives on the bandit, and shoots it before it recovers. Alternatively, the participants may begin a series of barrel rolls instead of break turns. This maintains some energy due to the altitude/speed tradeoffs, but is far from an ideal solution.

Each time the aircraft cross, they risk both collision and gunfire. Passing too far apart allows your opponent a guns snapshot while passing too close usually results in a crash. In short, scissoring is not good.

If you find yourself in a scissors, how do you get out? In a guns only environment, executing a split-S immediately after crossing your opponent's tail usually does the trick. If you can rapidly increase and maintain speed, you can extend beyond his gun range. Executing a split-S in a missile environment invites a heat seeker up your exhaust. If you can't get outside the

bandit's weapon range, then you have to win the scissors fight. If you can't win the fight by out-turning the bandit, you're dead.

Immelman

The immelman is a high-thrust, vertical reversal. Effected by pitching the nose up, low-thrust aircraft usually execute one-half of a loop and terminate the maneuver at a higher altitude, inverted, flying the opposite direction. High-thrust jets broaden the maneuver by climbing pure vertical, using an aileron roll during the climb, then completing the half loop. This effectively allows the aircraft to make square corners in the horizontal by displacing the vertical.

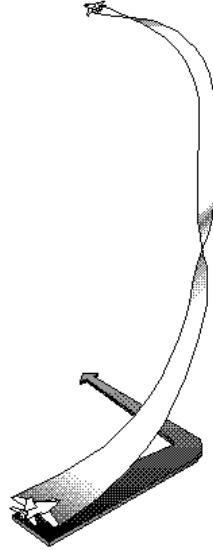

Split S

A split-S is a diving half loop. Rolling inverted and pulling back on the stick causes the aircraft to dive. Maintain back pressure until the aircraft levels out heading in the opposite direction.

The split-S gains speed quickly. Besides diving, rolling inverted adds the aircraft's lift vector to gravity, thus increasing acceleration. On the down side, the increased speed increases vertical turning radius. Start a split-S from low altitude or maintain too much speed during the dive and the aircraft won't be able to pull out.

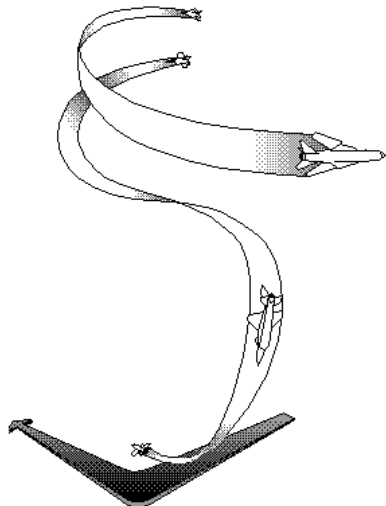

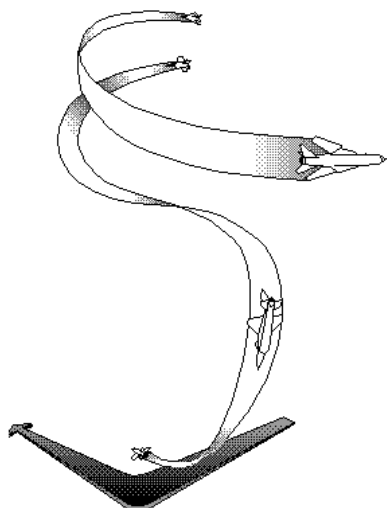

The split-S makes a great escape maneuver in a guns-only environment because of the rapid speed gain. It's usually ineffective in missile environments, though, since missiles have significantly longer ranges.

Ground Attack

Surviving ground-attack missions boils down to hitting the enemy while not getting hit yourself.

Surprise

Surprising the enemy is always a good thing. Try flying low, 500 ft or less, under the enemy's radar. Ground-based radar systems can detect your aircraft at high altitude but not close to the ground. Many enemy air-defense units have to physically move to engage your aircraft. If you approach undetected from an unexpected direction the air-defenses may be unprepared. It takes them time to turn and engage, giving you an opportunity to deliver ordnance and escape.

Radar also cannot penetrate fixed objects, like hills and buildings. Try flying low between hills or behind clusters of buildings to hide from enemy radar.

Remain Outside Enemy Range

Try to stay outside of enemy defense envelopes. For example, if the target is heavily defended with radar-guided SAMs, approach at low altitude; such SAMs often have trouble engaging low-altitude targets. If the primary defense is anti-aircraft artillery (AAA), stay above 5,000 feet; AAA cannot reach that high.

Similarly, try using long-ranged standoff weapons. If the enemy defenses have a maximum range of 20 nm, attack with a 30 nm-ranged weapon. This keeps you safely outside of the enemy's defenses. Obviously, standoff weapons won't always be available or suitable for a given mission, but always consider using them.

AAA Weaknesses

AAA is deadly against low-altitude targets but does have limitations. While modern AAA uses radar to calculate lead requirements, older AAA systems must eyeball you in their sights. Older AAA systems, therefore, must lead you

— if you approach them from any direction other than head on, you're almost guaranteed that they'll miss. Further, the faster you fly and the more you jink, the harder it is for AAA to calculate lead.

Chapter 7

DESIGNING PRO MISSIONS

Using the Pro Mission Creator you can create complex combat situations with multiple aircraft, ground forces, and complex mission objectives.

To view the Pro Mission Creator, click on **Create Pro Mission** in the Choose Activity Menu.



Though creating a challenging mission is more of an art than a science — requiring many modifications until the mission is suitably “difficult” — the process can be boiled down to a few basic activities:

- Determining an objective for each side
- Choosing weather and time of day
- Adding friendly and enemy units
- Assigning units objectives and waypoints

Determining An Overall Objective

All missions begin with objectives, that is, what each side is attempting to accomplish. Objectives should be thought of in terms of attacking and countering an attack. If one side’s objective is to strike a target, the other side’s objective is to defend it. Even air superiority missions require offensive and defensive roles – one side flies in to sweep the enemy from the skies, while the other rises up to counter them.

An interesting mission requires a challenging goal and well-balanced gameplay. If the mission is too simple or too hard, players will lose interest. Your goal as mission designer is to create a challenging but achievable mission.

Setting Friendly & Hostile Sides

The first step in creating your mission is deciding which countries are “friendly” and which countries are “hostile.”

To set hostile forces, select **Set friendly & enemy sides...** from the World Menu. A control panel appears:



Buttons that are **ON** are considered hostile; buttons that are not **ON** are automatically considered friendly. To change a country's alliance, click on its button.

Setting Weather/Time of Day

Weather conditions and time of day can help or hinder all sides in air combat. For example, cloud cover and darkness provide visual cover for attacking aircraft and create headaches for the defenders.

To choose the weather or time of day for your mission, select **Set weather...** from the World Menu. A control panel appears:



Select from the available weather conditions and times of day. Click OK or press Enter.

The Mission Map

The mission map displays the theater where the mission will take place.

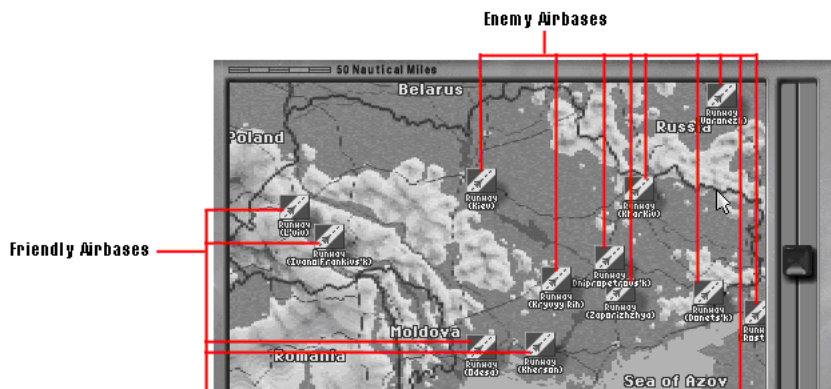

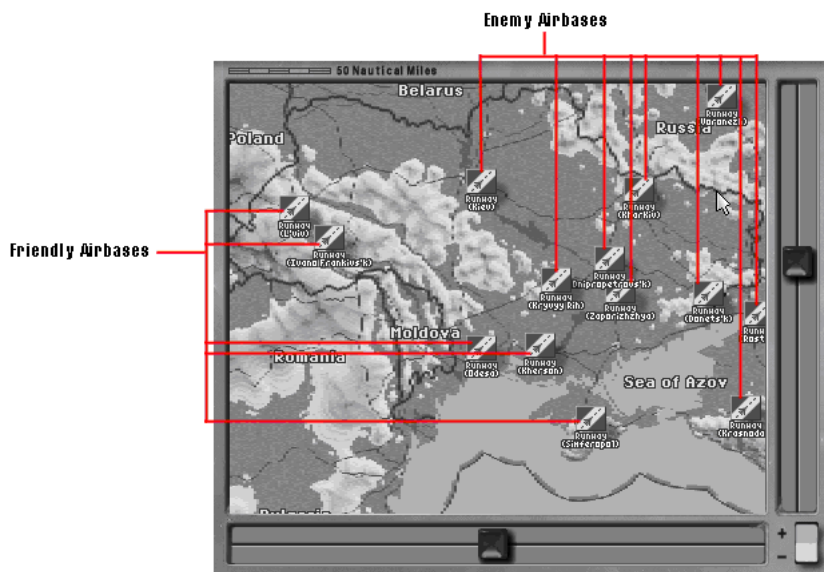

Even before you add aircraft, ships, and ground units to the world, there are a number of permanent objects — runways, bridges, roads, etc. — fixed on the map. You can see all permanent objects by selecting **Other** from the Show Menu.

Permanent objects cannot be deleted, changed, or assigned as mission objectives. They can be attacked during the mission, and fragile objects like buildings and bridges can be destroyed; however, damage done to permanent objects have no bearing on mission outcomes.

Viewing the Map

To zoom in and out on the mission map, click on either end of the Zoom Button or press **plus (+)** or **minus (-)**.

To scroll the mission map, point to either of the Scroll Buttons, hold down a mouse button, and drag. Alternately, you can scroll the map using the cursor **arrow** keys on your keyboard.

Adding Objects

Select **Add** from the Object Menu, or press **Insert**. The Add Object selection panel appears:

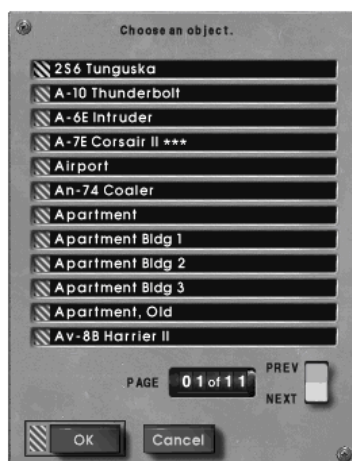

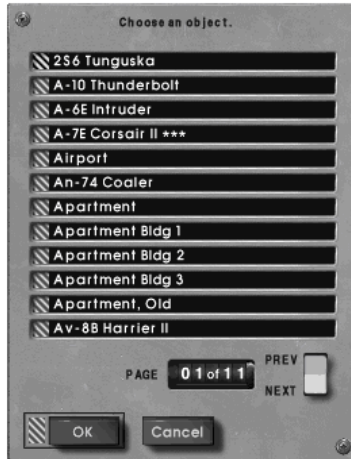

The selection panel lists all of the objects in U.S. Navy Fighters. Objects followed by asterisks (***) can be flown by players; all other objects must be controlled by the computer.

Click to choose an object, and then press **Enter**. The object's icon appears in the center of the map:



Note: If the object doesn't appear on the map, make sure that the class to which it belongs is currently activated in the Show Menu.

Selecting & Moving Units

Click on any unit to select it. To move a selected unit to another location, point to the unit icon, hold down the left mouse button, and drag the unit.

Duplicating Objects

Once you've created a unit, you can make as many copies of it as the mission requires. To duplicate a unit, select Duplicate from the Object Menu or press D.

Unit Options

Once an object is placed, you can define what kind of object is, its assignment, and its effect on the player's success or failure.

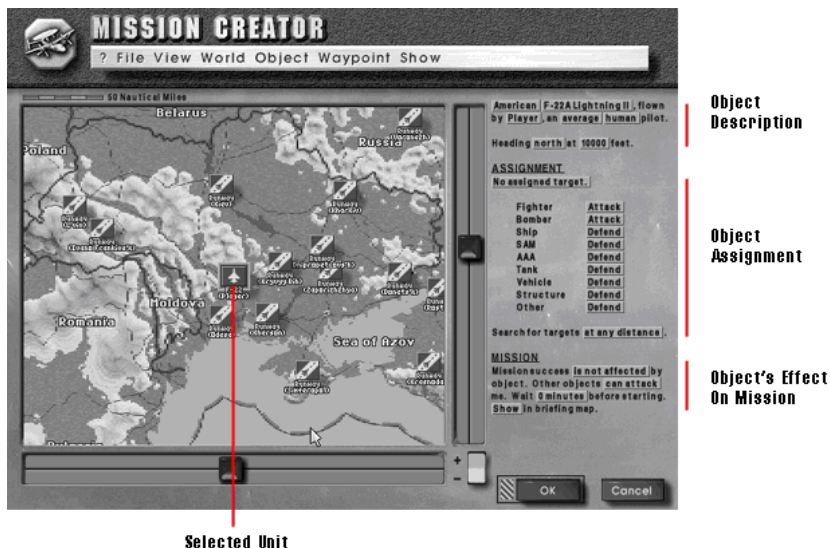

To modify the object, its assignment, or its effect on the mission, click on one of the text buttons.

Object Description

The text buttons at the top of the panel allow you to define the object.

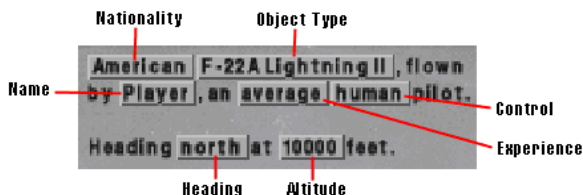

Nationality	Brings up the Choose Nationality selection panel, allowing you to change the object's nationality. Click on a nationality, and then click OK or press Enter .
Object Type	Brings up Choose Object selection panel, allowing you to change the type of object. Click on a new type, and then click OK or press Enter .
Name	Brings up the Enter Pilot Name panel. Type a name for the pilot, and then click OK or press Enter .
Experience	Click to choose the experience of the pilot: novice , average , good , or expert . Pilot experience affects many things: how well the pilot pays attention to his radar and RWR; his repertoire of offensive and defensive maneuvers; etc.
Control	Click to designate whether the pilot is controlled by a

human or the **computer**. Note that humans can only control a limited number of aircraft.

Heading

Click to give the object an initial heading: **north**, **south**, **east**, or **west**.

Speed

Click to give the object an initial speed, ranging from 0 to 3,000 kts. Note that setting a speed does not guarantee that the object is capable of that speed.

Object Assignment

The assignment options allow you to designate:

- An enemy the object should attack
- A friendly the object should protect
- The object's reactions to various classes of enemies

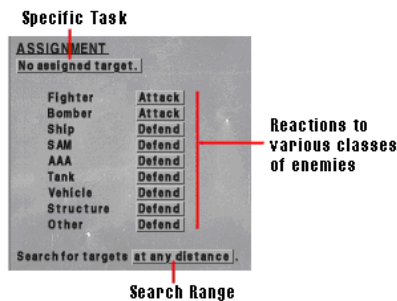

Specific Tasks

You can assign the object to destroy a target or protect a friendly object. Click on the text button, and then click on the enemy target or friendly object.

Reactions

For every aircraft, ship, and ground unit in the mission, you must specify reactions to various classes of enemies. You can set the following types of reactions:

Attack	Search for enemy targets of this class and attack them.
Defend	Defend if under attack from class type of enemy.
Ignore	Ignore enemies of this class.
Evade	Attempt to gain separation between you and any object of this class.

Search Range

You can designate the range at which the object will search for enemies. Note that any particular object is still limited by the range of its detection device.

Object's Effect On Mission

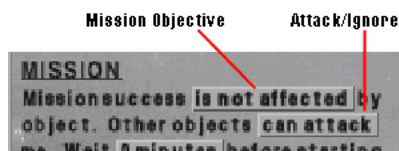

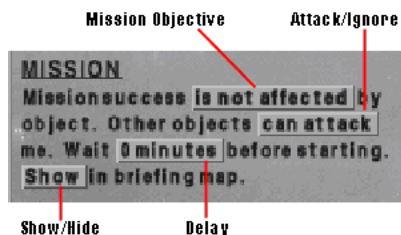

Mission Objective

The mission options let you designate the object as a “mission objective.” Mission objectives determine whether the player succeeded or failed. You can designate the following for the currently selected object:

Mission success is not affected by object.

The object has no bearing on the player’s success or failure.

Mission success only if object is destroyed.

The player must destroy the object in order to succeed.

Mission success only if object survives.

The player must protect the object from all aggressors.

Mission success only if object finishes waypoints.

The player must protect the object from all aggressors until the object finishes its waypoints.

Attack/Ignore

Choose whether other objects **can attack** or just **ignore** the object. This only affects computer-controlled enemies and in no way limits the player from attacking the object.

This option is basically a cheat for the mission designer — you can ensure that computer-controlled objects do not do the player’s work by destroying mission objectives.

Delay

Allows you to force an object to wait before beginning its mission. Note that this only applies to objects on the ground. Aircraft at any altitude above ground level are moving and cannot be “delayed.”

Show/Hide

Lets you determine whether or not the player will see the object on the briefing map. This allows you to determine how current the player’s intelligence data is. Does he know where enemy SAM sites are located, or are air defenses unknown?

Creating Wings

Aircraft can operate together in groups called wings. A wing allows you to assign a single mission objective to up to six aircraft.

To create a wing, add a number of aircraft to the map. Click on one of the aircraft to select it. From the Waypoint Menu, highlight **Add To Wing**. A submenu appears listing six wing “colors.”

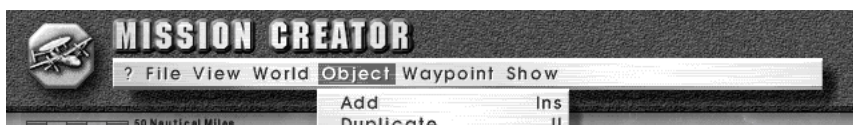



Highlight the color of the new wing and release the mouse button. Add the rest of the aircraft to the wing in the same manner. Now when you give orders to one aircraft in the wing, the other aircraft receive those orders, too.

Stationing Aircraft at Airbases & on Carriers

Single aircraft and wings can be stationed at airbases or on carriers. Grounded aircraft do not appear on enemy radar until they take to the air.

To set an aircraft or wing at an airbase or carrier, click on the aircraft icon. Drag the icon and place it over the runway or carrier icon. Point at the altitude text button and left-click until the altitude reads **ground level**.

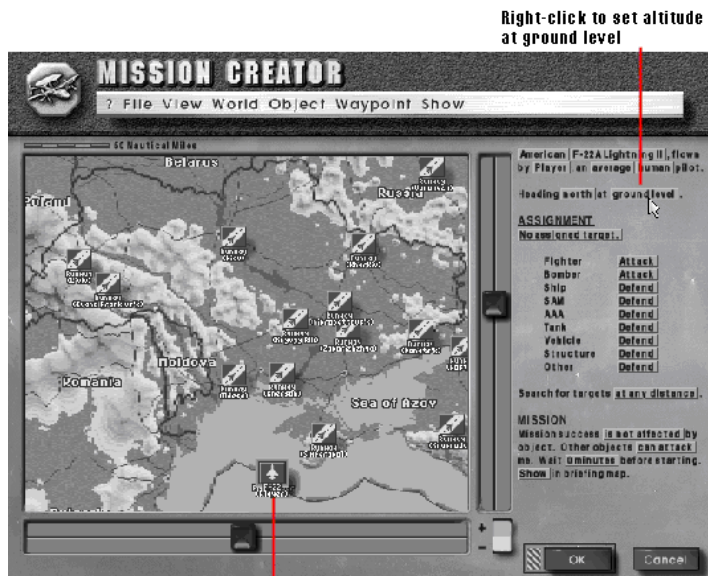

Aircraft icon on top of airbase icon

The aircraft represented by the icon are automatically deployed to the airbase

or carrier.

Delaying Take Off

Unless directed to wait, grounded aircraft will immediately take off from their base when the mission begins. You can, however, direct any aircraft to “wait” before beginning their mission. As a mission designer, this gives you the option of keeping enemy air units completely hidden until the you want them to begin their mission.

To delay take off, click on the grounded unit to select it. Point at the text button and click until the appropriate delay time appears.

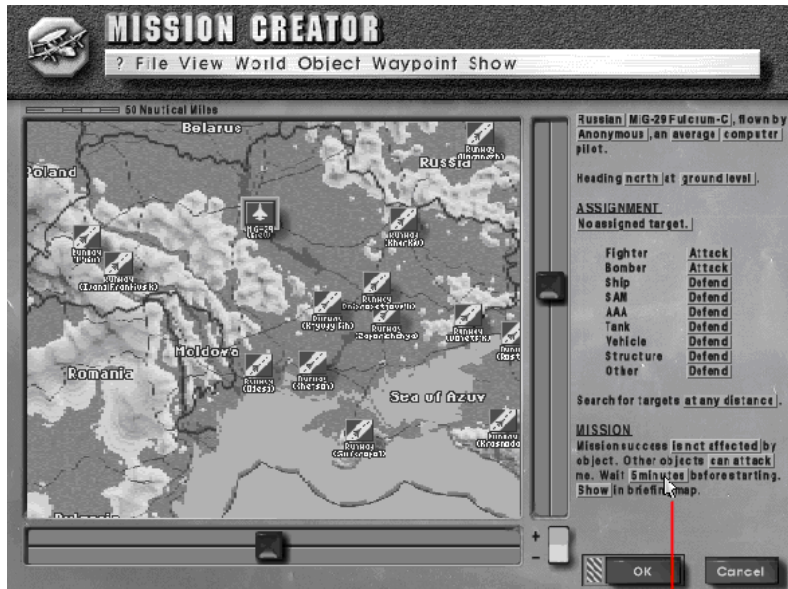

Delay text button

Setting Waypoints & Mission Objectives

Waypoints allow you to specify a series of actions for a given unit — where it will go and what its response to enemy units will be. You can assign waypoints to any object that can logically move: aircraft, ships, and ground units.

Adding Waypoints

Select the unit you wish to assign waypoints. Select **Add** from the Waypoint Menu or press **A**. A waypoint marker appears on the map:





Waypoint Formation

The formation, spacing, stacking, and control text buttons apply only to wings. These allow you to control how the aircraft in the wing fly to their waypoint.

The various formation and stacking options available to you are illustrated below:

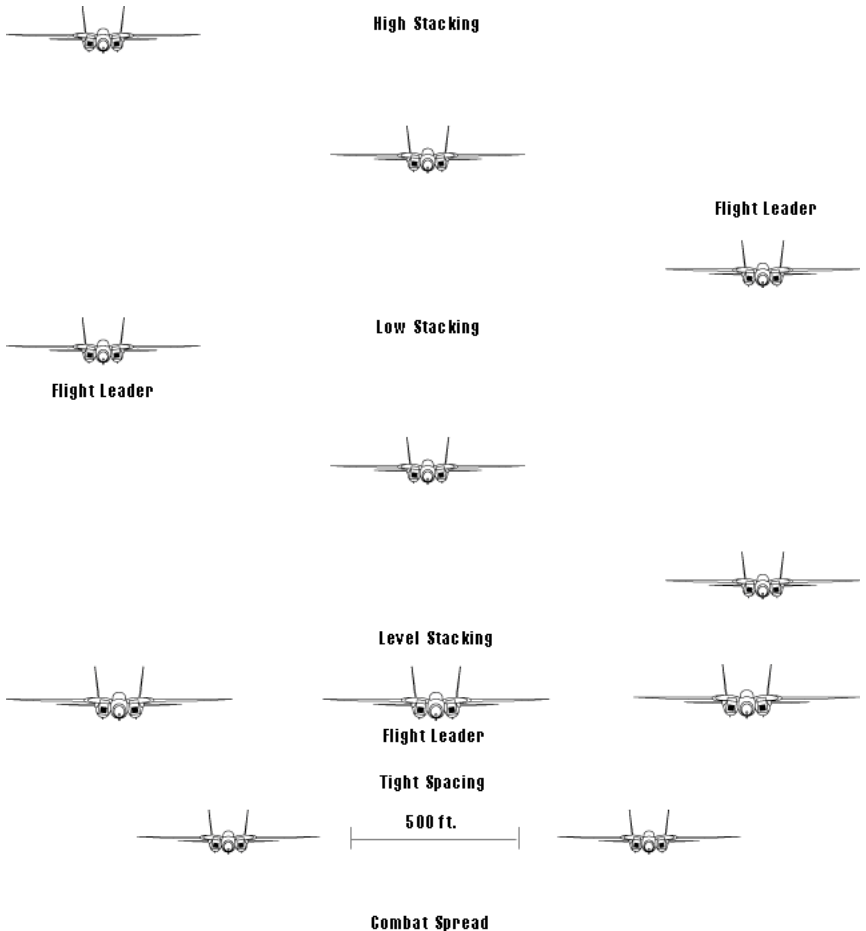

Tight Spacing



Combat Spread

2000 ft.

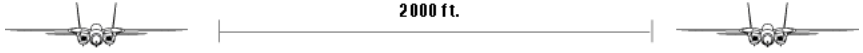

Line Abreast

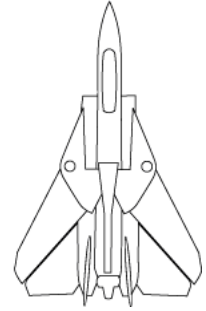
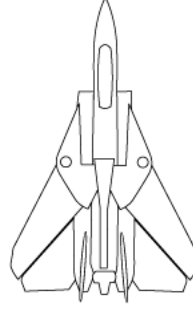
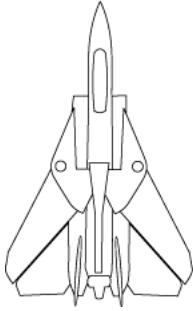

Line Astern

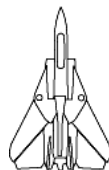
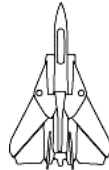
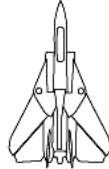

Echelon

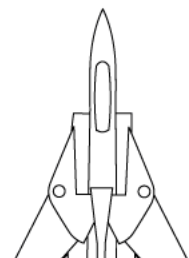
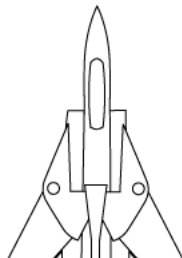
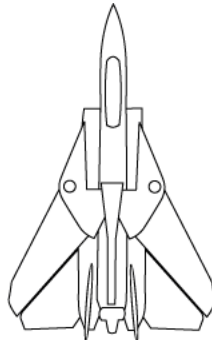

Echelon

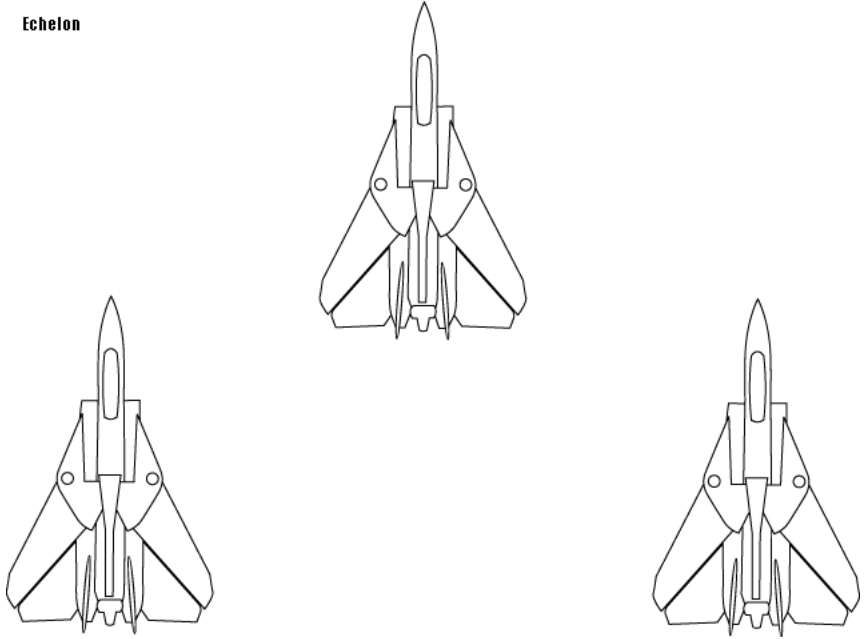

Waypoint Assignment

You can set waypoint objectives by clicking on the reaction text buttons, or by supplying the object with a preset waypoint assignments.

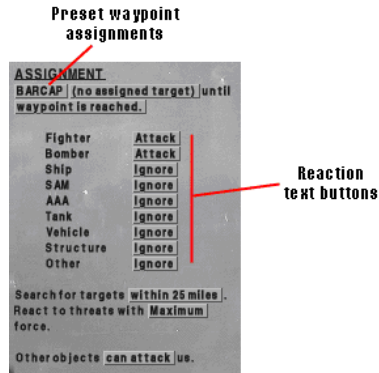

Preset waypoint assignments are as follows:

Assignment	Task Performed
Normal Flight	Executes as defined by subsequent text boxes.
MIGCAP	Seek out and destroy enemy aircraft near specified waypoint
BARCAP	Engage any aircraft attempting to cross the patrol zone
CAS	Close Air Support, engage enemy ground targets
Evade	Avoid all contact with the enemy. Useful for bypassing patrols on ingress or for AWACS aircraft.

Escort	Fly with and protect the designated units.
Search and Destroy	Fly to the point and look for targets of any type.
Attack	Attack a specific, named target.
Wild Weasel	Attack enemy air defenses.

Saving Custom Missions

Once you've set up a mission, select **Save Mission...** from the File Menu. Type in a name for the mission, and then click **OK** or press enter. The file will appear in your USNF directory with a ".mt" extension attached to it.

Playing Custom Missions

There are two ways you can test custom missions that you've created. You can load them into the Pro Mission Creator and select the **OK** button. This takes you directly to the mission, where you can tune the mission to make it more challenging or playable. Alternately, you can load the mission from the Fly Single Mission Screen.

Pro Mission Creator Menu Bar

File Menu

The File Menu allows you to save missions to file and to retrieve previously saved missions.

Option	Key Equivalent	Description
New mission	Ctrl-N	Erase all added objects and reset the map to its default state.
Load mission	L	Load a previously saved mission. Click to highlight the mission you want to load, and then click on the OK button.
Save mission	S	Save current mission. You will be prompted to enter a filename. Type the name of your mission and click on the OK button.

View Menu

The View Menu lets you control your view of the map.

Option	Key Equivalent	Description
--------	----------------	-------------

Scroll left	cursor left	Scroll map view left.
Scroll right	cursor right	Scroll map view right.
Scroll up	cursor up	Scroll map view up.
Scroll down	cursor down	Scroll map view down.
Center map at cursor	N	Center the map display on the current cursor position.
Center map at selection	B	Center the map display on the currently selected object.
Zoom in	plus (+)	Zoom in on map.
Zoom out	minus (-)	Zoom out on map.
Smart zoom		When activated, you zoom in and out on the currently selected object. If no object has been selected, you zoom in and out on the center of the map.

World Menu

The World Menu controls map and mission parameters which apply to the entire scenario. The World Menu also allows the mission designer to decide whether the player has access to various game shell screens.

Option	Description
Set map	Choose a map for your scenario. In the original <i>U.S. Navy Fighters</i> , this includes the UKR map.
Set weather	Choose weather and time of day effects for the mission: Clear, Cloud Cover, Fog, Sunrise, Sunset, Night.
Set friendly & enemy sides	This allows you to choose which nations ally themselves. Each mission has two generic sides, <i>friendly</i> and <i>enemy</i> . Although you may fly for either side, friendly forces are always shown in blue while enemy forces are shown in red.

Each country has a lighted button that can be turned on and off. Clicking the button so that its unlit allies the selected country with the friendly, or blue, forces. Clicking the button to ON allies the selected country with enemy, or red, forces.

In combat, "allied nations" will not attack each other.

Blue units will only attack red units while red units will only attack blue units.

Set screens

Determine what screens the player has access to when executing this mission. You may restrict or grant access to the Briefing Paper, Briefing Map, Select Plane, or Arm Plane screens. For example, denying access to the Select Plane screen forces the player to fly the mission with the aircraft you specified. Granting access to the Arm Plane screen allows the user to arm the plane according to their tastes rather than using the default weapon load.

Friendly pilot skills

Specify the default skill level for friendly pilots by selecting from the sub-menu.

Friendly SAM skills

Specify the default skill level for friendly air defenses by selecting from the sub-menu.

Enemy pilot skills

Specify the default skill level for enemy pilots by selecting from the sub-menu.

Enemy SAM skills

Specify the default skill level for enemy air defenses by selecting from the sub-menu.

Object Menu

The Object Menu controls creation and high-level control of individual units and wings. A “wing” is defined as a group of up to 5 aircraft operating together. The Pro Mission Creator allows up to 8 wings, each specified by a separate color.

Option	Key Equivalent	Description
Add	Insert	Adds units to the mission. A separate menu will appear allowing you to choose which unit to add. You may add only one item at a time. New units are not assigned to any wing.
Duplicate	U	Creates an exact duplicate of the last unit created.
Delete	Delete	Deletes the selected unit. Click on the unit, then select Delete.
Add to wing		Add an aircraft to a wing. Wings are groups of aircraft acting on a single purpose. The aircraft must already be selected in order to add it to a

wing.

Remove from wing

Remove the specified aircraft (appearing at the right of the map) from the currently selected wing.

Make wingleader

Make the specified aircraft (appearing at the right of the map) the leader of the wing. All other aircraft in the wing follow the actions of the wingleader.

Waypoint Menu

The waypoint menu controls movement of units and wings, as well as what actions those units and wings execute. The waypoint menu lets you create and delete waypoints as well as create "patrols" by looping waypoints.

Waypoint Menu

Option	Key Equivalent	Description
Add	A	Add a waypoint for a selected aircraft, wing, ship, or vehicle. The object must be selected before you can assign it a waypoint.
Delete	D	Delete a waypoint for a selected aircraft, wing, ship, or vehicle. The waypoint must be selected before you can delete it.
Create loop	C	Create a loop between two waypoints. Select the beginning waypoint, select Create loop, and then click on the end waypoint. The aircraft will travel from the initial waypoint, along any intermediary waypoints, until it reaches the end waypoint. It will repeat this process indefinitely.
Delete loop	E	Deletes a loop between two waypoints. Select the end waypoint, and then select Delete loop.
Select prev.	[Select the previous waypoint

waypoint

for the selected object.

**Select next
waypoint**

]

Select the next waypoint for
the selected object.

Show Menu

The Show Menu controls what classes of objects are currently displayed on the map. Complex missions may require “de-cluttering” the screen by disabling some frequently-appearing units, such as AAA and SAM sites. This menu allows you to hide classes of objects while building a mission.

When a check mark appears next to an object class, objects from that class are displayed on the map. To hide a class, select it from the menu; the check mark disappears and objects from that class are no longer shown on the map. The units still exist in their proper positions, they’re simply not displayed.

Chapter 8

TECHNICAL DATA

NATO Aircraft

Fairchild Republic A-10 Thunderbolt II



Structure

WINGSPAN: 57 ft 6 in

LENGTH: 53 ft 4 in

HEIGHT: 14 ft 8 in

DURABILITY: High

Performance

MAX G-LOAD: 6

MIN G-LOAD: -3

SUSTAINED G PERFORMANCE: High

Fuel

FUEL: 10,700 lbs

FUEL CONSUMPTION: 2 lbs/sec (military thrust)

Systems

RADAR SEARCH RANGE: 30 nm

RADAR TRACK RANGE: 30 nm

LOOKDOWN: Average

Gun

1 x 30mm gun (1,000 rounds)

Air-to-Air

AIM-9 Sidewinder AAM (2)

Air-to-Surface

AGM-65 Maverick ASM (8)

Grumman A-6E Intruder



Structure

WINGSPAN: 53 ft

LENGTH: 54 ft 9 in

HEIGHT: 16 ft 2 in

DURABILITY: Medium

Performance

MAX G-LOAD: 4

MIN G-LOAD: -2

SUSTAINED G PERFORMANCE: N/A

Fuel

FUEL: 15,470 lbs

FUEL CONSUMPTION: 2 lbs/sec (military thrust)

Systems

RADAR SEARCH RANGE: 50 nm

RADAR TRACK RANGE: 25 nm

LOOKDOWN: Superior

Gun

None

Air-to-Air

None

Air-to-Surface

AGM-65 Maverick ASM (12)

Vought A-7E Corsair II





Structure

WINGSPAN: 38 ft 9 in

LENGTH: 46 ft 1.5 in

HEIGHT: 16 ft 0.75 in

DURABILITY: Medium

Performance

MAX G-LOAD: 6

MIN G-LOAD: -3

SUSTAINED G PERFORMANCE: High

Fuel

FUEL: 9,900 lbs

FUEL CONSUMPTION: 2 lbs/sec (military thrust)

Systems

RADAR SEARCH RANGE: 75 nm

RADAR TRACK RANGE: 50 nm

LOOKDOWN: Average

Gun

1 x 20mm gun (1,000 rounds)

Air-to-Air

AIM-9 Sidewinder AAM (2)

Air-to-Surface

AGM-65 Maverick ASM (4)

Mark 82 GP bomb (2)

McDonnell Douglas AV-8B Harrier II

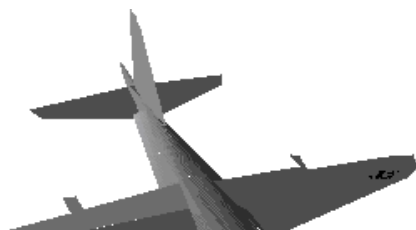



Structure

WINGSPAN: 30 ft 4 in

LENGTH: 46 ft 4 in

HEIGHT: 11 ft 8 in

DURABILITY: Medium

Performance

MAX G-LOAD: 7

MIN G-LOAD: -4

SUSTAINED G PERFORMANCE: High

Fuel

FUEL: 7,759 lbs

FUEL CONSUMPTION: 4 lbs/sec (military thrust)

Systems

RADAR SEARCH RANGE: 50 nm

RADAR TRACK RANGE: 30 nm

LOOKDOWN: Superior

Gun

1 x 25mm gun pod (300 rounds)

Air-to-Air

AIM-9 Sidewinder AAM (2)

Air-to-Surface

AGM-65 Maverick ASM (6)

Boeing B-52G Stratofortress

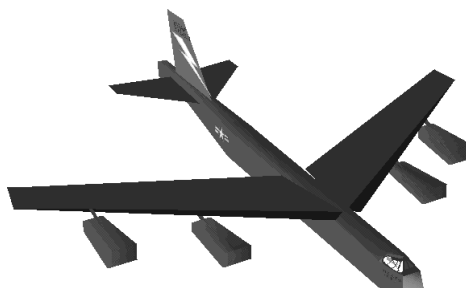

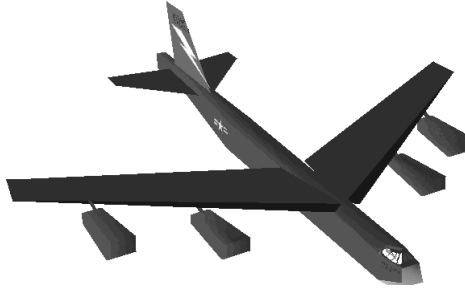

Structure

WINGSPAN: 185 ft

LENGTH: 160 ft 10.9 in

HEIGHT: 40 ft 8 in

DURABILITY: High

Performance

MAX G-LOAD: 3

MIN G-LOAD: -2

SUSTAINED G PERFORMANCE: N/A

Fuel

FUEL: 200,000 lbs

FUEL CONSUMPTION: 11 lbs/sec (military thrust)

Systems

RADAR SEARCH RANGE: 150 nm

RADAR TRACK RANGE: 150 nm

LOOKDOWN: Superior

Gun

1 x 20mm gun in tail of airplane

Air-to-Air

None

Air-to-Surface

AGM-84E SLAM (12)

Lockheed C-130H Hercules

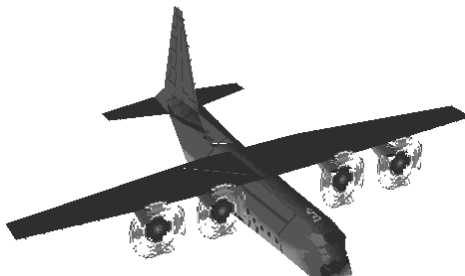

Structure

WINGSPAN: 132 ft 7 in

LENGTH: 112 ft 9 in

HEIGHT: 38 ft 3 in

DURABILITY: High

Performance

MAX G-LOAD: 3

MIN G-LOAD: -2

SUSTAINED G PERFORMANCE: N/A

Fuel

FUEL: 45,012 lbs

FUEL CONSUMPTION: 1 lbs/sec (military thrust)

Systems

RADAR SEARCH RANGE: N/A

RADAR TRACK RANGE: N/A

LOOKDOWN: N/A

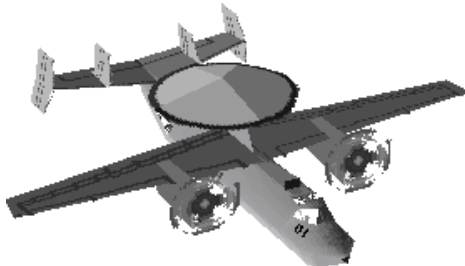
Grumman E-2C Hawkeye**Structure**

WINGSPAN: 80 ft 7 in

LENGTH: 57 ft 6.75 in

HEIGHT: 18 ft 3.75 in

DURABILITY: Medium

Performance

MAX G-LOAD: 3

MIN G-LOAD: -2

SUSTAINED G PERFORMANCE: N/A

Fuel

FUEL: 12,400 lbs

FUEL CONSUMPTION: 1 lbs/sec (military thrust)

Systems

RADAR SEARCH RANGE: 200 nm

RADAR TRACK RANGE: 200 nm

LOOKDOWN: Superior

Boeing E-3 Sentry



Structure

WINGSPAN: 145 ft 9 in

LENGTH: 152 ft 11 in

HEIGHT: 41 ft 9 in

DURABILITY: Medium

Performance

MAX G-LOAD: 3

MIN G-LOAD: -2

SUSTAINED G PERFORMANCE: N/A

Fuel

FUEL: 157,839 lbs

FUEL CONSUMPTION: 5 lbs/sec

Systems

RADAR SEARCH RANGE: 200 nm

RADAR TRACK RANGE: 200 nm

LOOKDOWN: Superior

Boeing E-8A JSTARS





Structure

WINGSPAN: 94 ft 9 in

LENGTH: 109 ft 7 in

HEIGHT: 36 ft 6 in

DURABILITY: High

Performance

MAX G-LOAD: 3

MIN G-LOAD: -2

SUSTAINED G PERFORMANCE: N/A

Fuel

FUEL: 157,839 lbs

FUEL CONSUMPTION: 5 lbs/sec (military thrust)

Systems

RADAR SEARCH RANGE: 300 nm

RADAR TRACK RANGE: 300 nm

LOOKDOWN: Superior

Grumman EA-6B Prowler

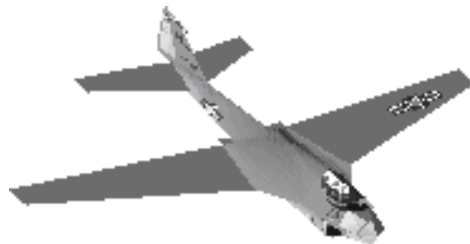

Structure

WINGSPAN: 53 ft

LENGTH: 59 ft 10 in

HEIGHT: 16 ft 3 in

DURABILITY: Medium

Performance

MAX G-LOAD: 4

MIN G-LOAD: -2

SUSTAINED G PERFORMANCE: N/A

Fuel

FUEL: 15,470 lbs

FUEL CONSUMPTION: 2 lbs/sec (military thrust)

Systems

RADAR SEARCH RANGE: 50 nm

RADAR TRACK RANGE: 25 nm

LOOKDOWN: Superior

Lockheed F-104 Starfighter



Structure

WINGSPAN: 21 ft 11 in

LENGTH: 54 ft 9 in

HEIGHT: 13 ft 6 in

DURABILITY: Medium

Performance

MAX G-LOAD: 5

MIN G-LOAD: -3

SUSTAINED G PERFORMANCE: Low

Fuel

FUEL: 10,000 lbs

FUEL CONSUMPTION: 7 lbs/sec (military thrust), 26 lbs/sec (afterburner)

Systems

RADAR SEARCH RANGE: 50

RADAR TRACK RANGE: 25

LOOKDOWN: Inferior

Guns

1 x 20mm cannon (720 rounds)

Air-to-Air

AIM-7 Sparrow AAM (4)

AIM-9 Sidewinder AAM (2)

Air-to-Surface

None

Grumman F-14B Tomcat

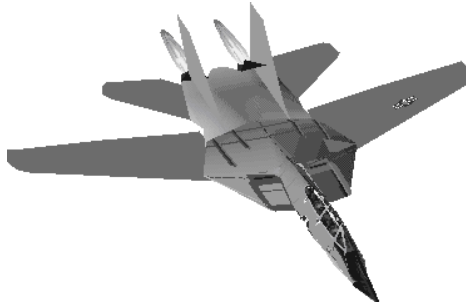

Structure

WINGSPAN: 38 ft 2.5 in (swept); 33 ft

3.5 in (overswept)

LENGTH: 62 ft 8 in

HEIGHT: 16 ft

DURABILITY: High

Performance

MAX G-LOAD: 9

MIN G-LOAD: -4

SUSTAINED G PERFORMANCE: Low

Fuel

FUEL: 15,741 lbs

FUEL CONSUMPTION: 6 lbs/sec (military thrust), 21 lbs/sec (afterburners)

Systems

RADAR SEARCH RANGE: 190 nm

RADAR TRACK RANGE: 100 nm

LOOKDOWN: Average

Gun

1 x 20mm gun (675 rounds)

Air-to-Air

AIM-9 Sidewinder AAM (2)

AIM-54 Phoenix AAM (4)

AIM-120 AMRAAM (4)

Air-to-Surface

None

McDonnell Douglas F-15C Eagle

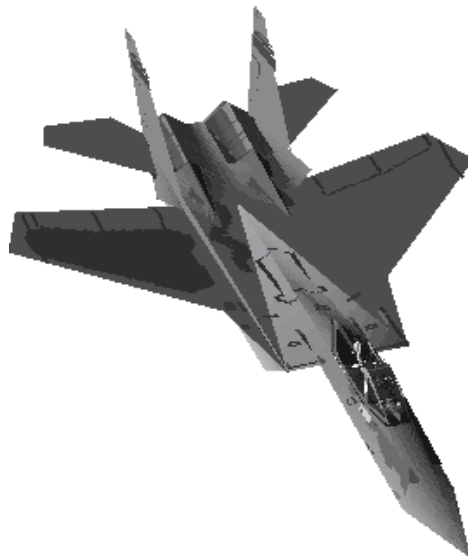

Structure

WINGSPAN: 49 ft 9.75 in

LENGTH: 63 ft 9 in

HEIGHT: 18 ft 7.5 in

DURABILITY: Medium

Performance

MAX G-LOAD: 9

MIN G-LOAD: -4

SUSTAINED G PERFORMANCE: Low

Fuel

FUEL: 13,662 lbs

FUEL CONSUMPTION: 7 lbs/sec (military thrust), 24 lbs/sec (afterburners)

Systems

RADAR SEARCH RANGE: 150 nm

RADAR TRACK RANGE: 75 nm

LOOKDOWN: Average

Gun

1 x 20mm gun (940 rounds)

Air-to-Air

AIM-9 Sidewinder AAM (4)

AIM-120 AMRAAM (4)

Air-to-Surface

None

McDonnell Douglas F/A-18D Hornet



Structure

WINGSPAN: 37 ft 6 in

LENGTH: 56 ft

HEIGHT: 15 ft 3.5 in

DURABILITY: Medium

Performance

MAX G-LOAD: 9

MIN G-LOAD: -4

SUSTAINED G PERFORMANCE: Medium

Fuel

FUEL: 11,220 lbs

FUEL CONSUMPTION: 4 lbs/sec (military thrust), 16 lbs/sec (afterburner)

Systems

RADAR SEARCH RANGE: 90 nm

RADAR TRACK RANGE: 45 nm

LOOKDOWN: Superior

Gun

1 x 20mm gun (570 rounds)

Air-to-Air

AIM-9 Sidewinder AAM (2)

AIM-120 AMRAAM (2)

Air-to-Surface

AGM-65 Maverick ASM (8)

McDonnell Douglas F/A-18C Hornet**Structure**

WINGSPAN: 37 ft 6 in

LENGTH: 56 ft

HEIGHT: 15 ft 3.5 in

DURABILITY: Medium

Performance

MAX G-LOAD: 9

MIN G-LOAD: -4

SUSTAINED G PERFORMANCE: Medium

Fuel

FUEL: 11,220 lbs

FUEL CONSUMPTION: 4 lbs/sec (military thrust), 16 lbs/sec (afterburner)

Systems

RADAR SEARCH RANGE: 90 nm

RADAR TRACK RANGE: 45 nm

LOOKDOWN: Superior

Gun

1 x 20mm gun (570 rounds)

Air-to-Air

AIM-9 Sidewinder AAM (2)

AIM-120 AMRAAM (8)

Air-to-Surface

AGM-65 Maverick ASM (2)

Lockheed F-22 Lightning II

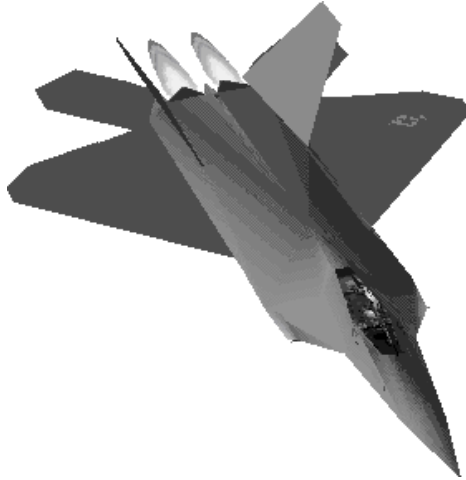

Structure

WINGSPAN: 44 ft 6 in

LENGTH: 62 ft 1 in

HEIGHT: 16 ft 5 in

DURABILITY: Medium

Performance

MAX G-LOAD: 9

MIN G-LOAD: -4

SUSTAINED G PERFORMANCE: Low

Fuel

FUEL: 13,662 lbs

FUEL CONSUMPTION: 10 lbs/sec (military thrust), 35 lbs/sec (afterburner)

Systems

RADAR SEARCH RANGE: 150 nm

RADAR TRACK RANGE: 150 nm

LOOKDOWN: Superior

Gun

1 x 20mm gun (750 rounds)

Air-to-Air

AIM-9 Sidewinder AAM (4)

AIM-120 AMRAAM (4)

Air-to-Surface

AGM-65 Maverick ASM (4)

Boeing KC-135A Stratotanker



Structure

WINGSPAN: Unavailable

LENGTH: Unavailable

HEIGHT: Unavailable

DURABILITY: High

Performance

MAX G-LOAD: 3

MIN G-LOAD: -2

SUSTAINED G PERFORMANCE: N/A

Fuel

FUEL: 157,839 lbs

FUEL CONSUMPTION: 5 lbs/sec

Systems

RADAR SEARCH RANGE: N/A

RADAR TRACK RANGE: N/A

LOOKDOWN: N/A

Sikorsky S-60B Seahawk



Structure

ROTOR: 53 ft 8 in

LENGTH: 64 ft 10 in

HEIGHT: 16 ft 10 in

DURABILITY: Medium

Performance

MAX G-LOAD: 3

MIN G-LOAD: -1

SUSTAINED G PERFORMANCE: N/A

Fuel

FUEL: 2,376 lbs

FUEL CONSUMPTION: 1 lbs/sec (military thrust)

Systems

RADAR SEARCH RANGE: N/A

RADAR TRACK RANGE: N/A

LOOKDOWN: N/A

Russian Aircraft

Antonov An-74 'Coaler'



Structure

WINGSPAN: 84 ft 9 in

LENGTH: 87 ft 2.25 in

HEIGHT: 27 ft 0.25 in

DURABILITY: Medium

Performance

MAX G-LOAD: 3

MIN G-LOAD: -2

SUSTAINED G PERFORMANCE: N/A

Fuel

FUEL: 28,550 lbs

FUEL CONSUMPTION: 2 lbs/sec (military thrust)

Systems

RADAR SEARCH RANGE: N/A

RADAR TRACK RANGE: N/A

LOOKDOWN: N/A

Ilyushin Il-96-300

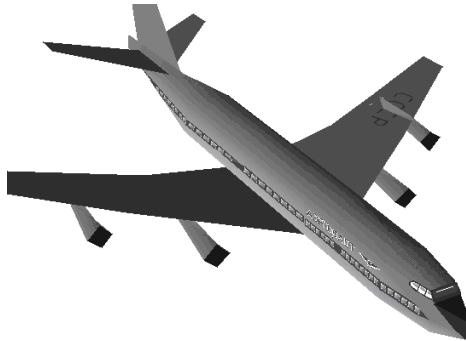

Structure

WINGSPAN: 197 ft 2.5 in

LENGTH: 181 ft 7.25 in

HEIGHT: 57 ft 7.75 in

DURABILITY: High

Performance

MAX G-LOAD: 3

MIN G-LOAD: -2

SUSTAINED G PERFORMANCE: N/A

Fuel

FUEL: 253,311 lbs

FUEL CONSUMPTION: 8 lbs/sec (100% throttle)

Systems

RADAR SEARCH RANGE: N/A

RADAR TRACK RANGE: N/A

LOOKDOWN: N/A

Kamov Ka-50 'Hokum'

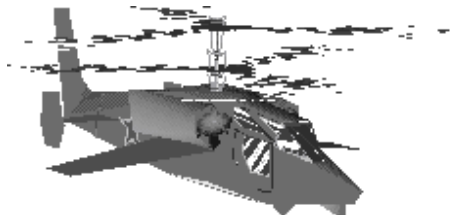

Structure

ROTOR: 47 ft 7 in

LENGTH: 52 ft 6 in

HEIGHT: Unknown

DURABILITY: Medium

Performance

MAX G-LOAD: 4

MIN G-LOAD: -1

SUSTAINED G PERFORMANCE: N/A

Fuel

FUEL: 2,000 lbs

FUEL CONSUMPTION: 1 lbs/sec

Systems

RADAR SEARCH RANGE: 10 nm

RADAR TRACK RANGE: 10 nm

LOOKDOWN: Superior

Gun

1 x 30mm gun (1000 rounds)

Air-to-Air

AA-8 'Aphid' AAM (2)

Air-to-Surface

AT-12 'Swinger' ASM (10)

Mil Mi-24 'Hind-D'

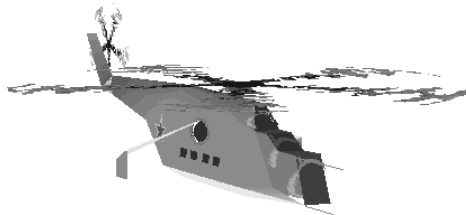

Structure

ROTOR: 55 ft 9 in

LENGTH: 57 ft 5 in

HEIGHT: 21 ft 4 in

DURABILITY: Medium

Performance

MAX G-LOAD: 3

MIN G-LOAD: -1

SUSTAINED G PERFORMANCE: N/A

Fuel

FUEL: 3,307 lbs

FUEL CONSUMPTION: 1 lbs/sec

Systems

RADAR SEARCH RANGE: None

RADAR TRACK RANGE: None

LOOKDOWN: N/A

Gun

12.5mm gun (750 rounds)

Air-to-Air

None

Air-to-Surface

AT-12 'Swinger' ASM

Mikoyan/Gurevich MiG-21 'Fishbed-J'

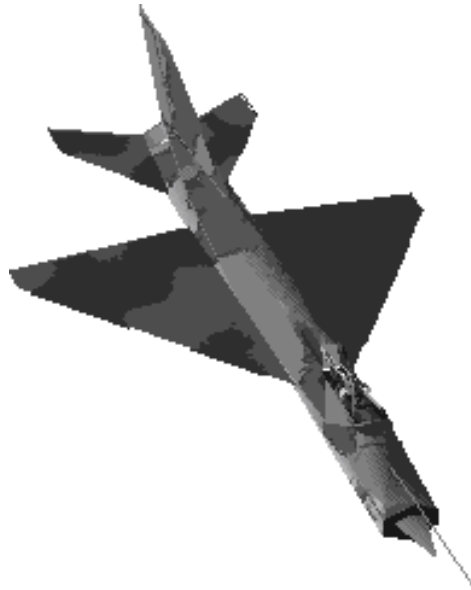

Structure

WINGSPAN: 23 ft 5.5 in

LENGTH: 51 ft 8.5 in

HEIGHT: 14 ft 9 in

DURABILITY: Medium

Performance

MAX G-LOAD: 8

MIN G-LOAD: -4

SUSTAINED G PERFORMANCE: Medium

Fuel

FUEL: 4,534 lbs

FUEL CONSUMPTION: 2 lbs/sec (military thrust), 7 lbs/sec (afterburner)

Systems

RADAR SEARCH RANGE: 18 nm

RADAR TRACK RANGE: 9 nm

LOOKDOWN: Inferior

Gun

1 x 23mm gun (200 rounds)

Air-to-Air

AA-2 'Atoll' (4)

Air-to-Surface

None

Mikoyan/Gurevich MiG-27 'Flogger-J'



Structure

WINGSPAN: 45 ft 9 in

LENGTH: 52 ft 6 in

HEIGHT: 18 ft 10.25 in

DURABILITY: Medium

Performance

MAX G-LOAD: 8

MIN G-LOAD: -4

SUSTAINED G PERFORMANCE: Medium

Fuel

FUEL: 10,000 lbs

FUEL CONSUMPTION: 3 lbs/sec (military thrust), 13 lbs/sec (afterburner)

Systems

RADAR SEARCH RANGE: 43 nm

RADAR TRACK RANGE: 34 nm

LOOKDOWN: Inferior

Gun

1 x 30mm gun (200 rounds)

Air-to-Air

AA-2 'Atoll' (2)

Air-to-Surface

AS-7 'Kerry' (4)

Mikoyan/Gurevich MiG-29 'Fulcrum-C'



Structure

WINGSPAN: 37 ft 8.75 in

LENGTH: 56 ft 5 in

HEIGHT: 14 ft 5.25 in

DURABILITY: Medium

Performance

MAX G-LOAD: 8

MIN G-LOAD: -4

SUSTAINED G PERFORMANCE: Medium

Fuel

FUEL: 13,000 lbs

FUEL CONSUMPTION: 4 lbs/sec (military thrust), 18 lbs/sec (afterburner)

Systems

RADAR SEARCH RANGE: 62 nm

RADAR TRACK RANGE: 43 nm

LOOKDOWN: Superior

Gun

1 x 30mm gun (150 rounds)

Air-to-Air

AA-8 'Aphid' (6)

Air-to-Surface

None

Mikoyan/Gurevich MiG-31 'Foxhound-A'



Structure

WINGSPAN: 45 ft 11.25 in

LENGTH: 70 ft 6.5 in

HEIGHT: 20 ft 0.25 in

DURABILITY: High

Performance

MAX G-LOAD: 4

MIN G-LOAD: -2

SUSTAINED G PERFORMANCE: Very Low

Fuel

FUEL: 30,865 lbs

FUEL CONSUMPTION: 7 lbs/sec (military thrust), 24 lbs/sec (afterburner)

Systems

RADAR SEARCH RANGE: 124 nm

RADAR TRACK RANGE: 75 nm

LOOKDOWN: Average

Gun

1 x 30mm gun (260 rounds)

Air-to-Air

AA-8 'Aphid' (2)

AA-9 'Amos' (4)

Air-to-Surface

None

Sukhoi Su-24 'Fencer-D'



Structure

WINGSPAN: 57 ft 5 in

LENGTH: 69 ft 10 in

HEIGHT: 19 ft 8.25 in

DURABILITY: High

Performance

MAX G-LOAD: 6

MIN G-LOAD: -3

SUSTAINED G PERFORMANCE: N/A

Fuel

FUEL: 22,664 lbs

FUEL CONSUMPTION: 7 lbs/sec (military thrust), 25 (afterburner)

Systems

RADAR SEARCH RANGE: 50 nm

RADAR TRACK RANGE: 35 nm

LOOKDOWN: Superior

Gun

1 x 23mm gun (200 rounds)

Air-to-Air

None

Air-to-Surface

AS-14 'Kedge' (4)

Sukhoi Su-27 'Flanker-B'

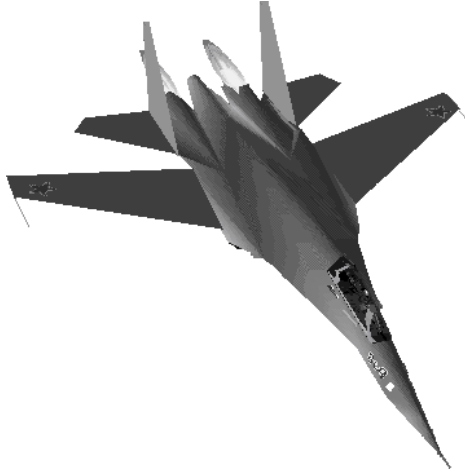

Structure

WINGSPAN: 48 ft 2.75 in

LENGTH: 70 ft 10.5 in

HEIGHT: 18 ft

DURABILITY: Medium

Performance

MAX G-LOAD: 9

MIN G-LOAD: -4

SUSTAINED G PERFORMANCE: Low

Fuel

FUEL: 22,000 lbs

FUEL CONSUMPTION: 8 lbs/sec (military thrust), 30 lbs/sec (afterburner)

Systems

RADAR SEARCH RANGE: 150 nm

RADAR TRACK RANGE: 115 nm

LOOKDOWN: Superior

Gun

1 x 30mm gun (150)

Air-to-Air

AA-11 'Archer' (2)

AA-12 'Amraamski' (4)

Air-to-Surface

None

Sukhoi Su-33 'Flanker-D'



Structure

WINGSPAN: 48 ft 2.75 in

LENGTH: 70 ft 10.5 in

HEIGHT: 18 ft

DURABILITY: Medium

Performance

MAX G-LOAD: 9

MIN G-LOAD: -4

SUSTAINED G PERFORMANCE: Low

Fuel

FUEL: 22,000 lbs

FUEL CONSUMPTION: 8 lbs/sec (military thrust), 30 lbs/sec (afterburner)

Systems

RADAR SEARCH RANGE: 150 nm

RADAR TRACK RANGE: 115 nm

LOOKDOWN: Superior

Gun

1 x 30mm gun (150 rounds)

Air-to-Air

AA-11 'Archer' (2)

AA-12 'Amraamski' (4)

Air-to-Surface

None

Sukhoi Su-34 'Flanker'



Structure

WINGSPAN: 48 ft 2.75 in

LENGTH: 70 ft 10.5 in

HEIGHT: 18 ft

DURABILITY: Medium

Performance

MAX G-LOAD: 9

MIN G-LOAD: -4

SUSTAINED G PERFORMANCE: Low

Fuel

FUEL: 20,000 lbs

FUEL CONSUMPTION: 8 lbs/sec (military thrust), 30 lbs/sec (afterburner)

Systems

RADAR SEARCH RANGE: 150 nm

RADAR TRACK RANGE: 115 nm

LOOKDOWN: Superior

Gun

1 x 30mm gun (150 rounds)

Air-to-Air

AA-11 'Archer' (2)

Air-to-Surface

AS-14 'Kedge' ASM (4)

Sukhoi Su-37 'Flounder-A'

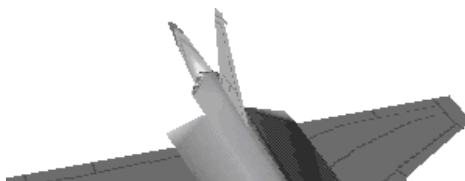

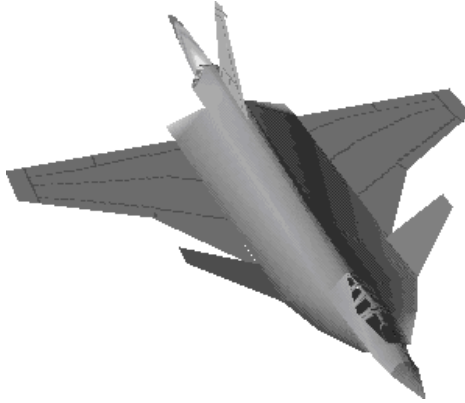

Structure

WINGSPAN: 38 ft 8.5 in

LENGTH: 57 ft 5 in

HEIGHT: Unknown

DURABILITY: Medium

Performance

MAX G-LOAD: 9

MIN G-LOAD: -4

SUSTAINED G PERFORMANCE: Low

Fuel

FUEL: 20,000 lbs

FUEL CONSUMPTION: 4 lbs/sec (military thrust), 16 lbs/sec (afterburner)

Systems

RADAR SEARCH RANGE: 62 nm

RADAR TRACK RANGE: 43 nm

LOOKDOWN: Superior

Gun

1 x 30mm gun (200 rounds)

Air-to-Air

AA-11 'Archer' AAM (2)

Air-to-Surface

AS-14 'Kedge' ASM (4)

Tupolev Tu-160 'Blackjack'

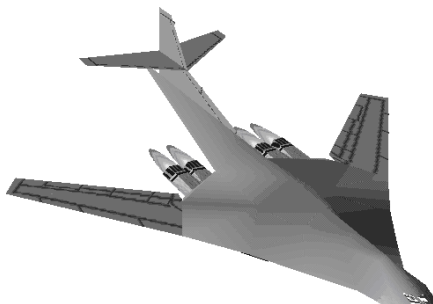

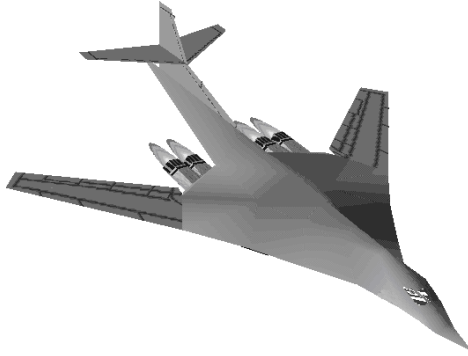

Structure

WINGSPAN: 182 ft 9 in (unswept), 116 ft 9.75 in (swept)

LENGTH: 177 ft 6 in

HEIGHT: 43 ft 0 in

DURABILITY: High

Performance

MAX G-LOAD: 5

MIN G-LOAD: -2

SUSTAINED G PERFORMANCE: N/A

Fuel

FUEL: 368,000 lbs

FUEL CONSUMPTION: 32 lbs/sec (military thrust), 116 lbs/sec (afterburner)

Systems

RADAR SEARCH RANGE: 150 nm

RADAR TRACK RANGE: 150 nm

LOOKDOWN: Superior

Gun

None

Air-to-Air

None

Air-to-Surface

AS-16 'Kickback' (8) ASM

Tupolev Tu-26 'Backfire-C'

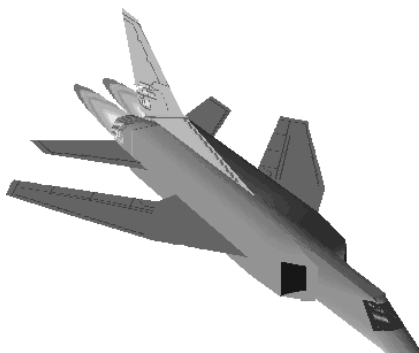

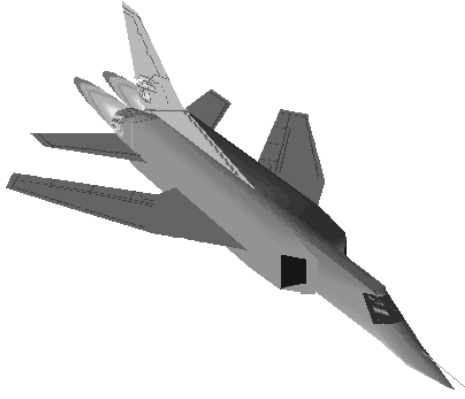

Structure

WINGSPAN: 112 ft 6.5 in (unswept), 76 ft 9.25 in (swept)

LENGTH: 129 ft 11 in

HEIGHT: 35 ft 5.25 in

DURABILITY: Medium

Performance

MAX G-LOAD: 4

MIN G-LOAD: -2

SUSTAINED G PERFORMANCE: N/A

Fuel

FUEL: 110,230 lbs

FUEL CONSUMPTION: 12 lbs/sec (military thrust), 44 lbs/sec (afterburner)

Systems

RADAR SEARCH RANGE: 100 nm

RADAR TRACK RANGE: 100 nm

LOOKDOWN: Superior

Gun

None

Air-to-Air

None

Air-to-Surface

AS-16 'Kickback' ASM (6)

Tupolev Tu-95 'Bear-D'

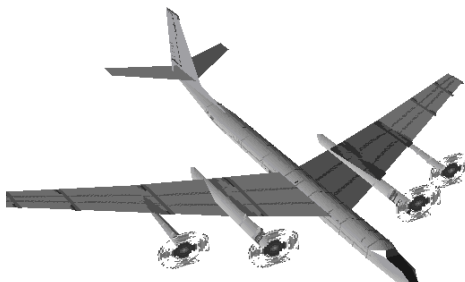

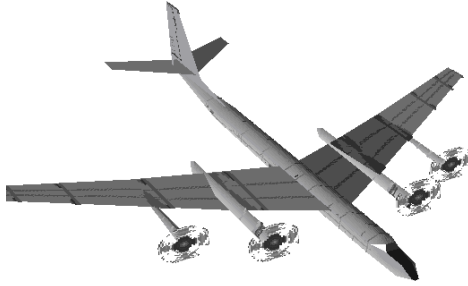

Structure

WINGSPAN: 167 ft 8 in

LENGTH: 162 ft 5 in

HEIGHT: 39 ft 9 in

DURABILITY: High

Performance

MAX G-LOAD: 3

MIN G-LOAD: -1

SUSTAINED G PERFORMANCE: N/A

Fuel

FUEL: 100,000 lbs

FUEL CONSUMPTION: 4 lbs/sec (military thrust)

Systems

RADAR SEARCH RANGE: 150 nm

RADAR TRACK RANGE: 150 nm

LOOKDOWN: Superior

Guns

3 x 23mm guns

Air-to-Air

None

Air-to-Surface

AS-16 'Kickback' ASM (6)

Yakovlev Yak-141 'Freestyle'

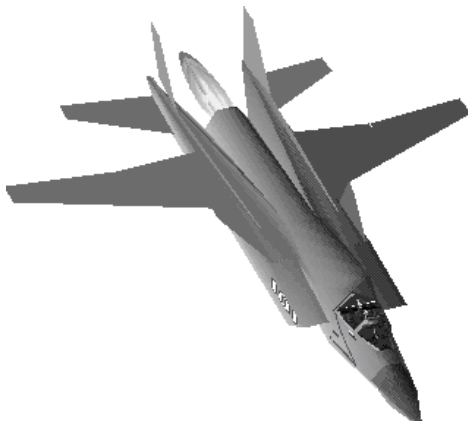



Structure

WINGSPAN: 33 ft 1.75 in

LENGTH: 19 ft 4.25 in

HEIGHT: 60 ft

DURABILITY: Medium

Performance

MAX G-LOAD: 7

MIN G-LOAD: -4

SUSTAINED G PERFORMANCE: Low

Fuel

FUEL: 9,700 lbs

FUEL CONSUMPTION: 4 lbs/sec (military thrust), 17 lbs/sec (afterburner)

Systems

RADAR SEARCH RANGE: 40 nm

RADAR TRACK RANGE: 20 nm

LOOKDOWN: Average

Gun

1 x 30mm gun (1000 rounds)

Air-to-Air

AA-10 'Alamo' (2)

AA-11 'Archer' (2)

Air-to-Surface

None

NATO Air-to-Air Missiles

AIM-7 Sparrow

TYPE: Medium-Range SARH Missile

WEIGHT: 505 lbs
MAX SPEED: 2,400 kts
MIN/MAX RANGE: 0.5 - 19.7 nm
ALL-ASPECT: Yes
LOOKDOWN: Poor
MAX HIT PROBABILITY:35%
WARHEAD: 39 kg
LETHALITY: High

AIM-9B Sidewinder

TYPE: Short-Range IR-Seeking Missile
WEIGHT: 170 lbs
MAX SPEED: 1,700 kts
MIN/MAX RANGE: 0 - 3.9 nm
ALL-ASPECT: No
LOOKDOWN: Superior
MAX HIT PROBABILITY:65%
WARHEAD: 5 kg
LETHALITY: Low

AIM-9M Sidewinder

TYPE: Short-Range IR-Seeking Missile
WEIGHT: 190 lbs
MAX SPEED: 1,800 kts
MIN/MAX RANGE: 0 - 3.9 nm
ALL-ASPECT: No
LOOKDOWN: Superior
MAX HIT PROBABILITY:85%
WARHEAD: 10 kg
LETHALITY: Medium

AIM-54C Phoenix

TYPE: Long-Range Active Radar Missile
WEIGHT: 975 lbs
MAX SPEED: 3,200 kts
MIN/MAX RANGE: 0.1 - 148 nm
ALL-ASPECT: Yes
LOOKDOWN: Average

MAX HIT PROBABILITY:75%

WARHEAD: 60 kg

LETHALITY: High

AIM-120 AMRAAM

TYPE: Medium-Range Active Radar Missile

WEIGHT: 345 lbs

MAX SPEED: 2,600 kts

MIN/MAX RANGE: 0 - 24.6 nm

ALL-ASPECT: Yes

LOOKDOWN: Superior

MAX HIT PROBABILITY:75%

WARHEAD: 22 kg

LETHALITY: High

Russian Air-to-Air Missiles

AA-2 Atoll

TYPE: Short-Range IR-Seeking Missile

WEIGHT: 165 lbs

MAX SPEED: 1,700 kts

MIN/MAX RANGE: 0 - 1.4 nm

ALL-ASPECT: No

LOOKDOWN: Superior

MAX HIT PROBABILITY:35%

WARHEAD: 11 kg

LETHALITY: Medium

AA-6 Acrid

TYPE: Medium-Range SARH Missile

WEIGHT: 1,010 lbs

MAX SPEED: 2,800 kts

MIN/MAX RANGE: 0 - 14.8 nm

ALL-ASPECT: Yes

LOOKDOWN: Poor

MAX HIT PROBABILITY:35%

WARHEAD: 70 kg

LETHALITY: High

AA-8 Aphid

TYPE: Short-Range IR-Seeking Missile

WEIGHT: 145 lbs

MAX SPEED: 2,100 kts

MIN/MAX RANGE: 0 - 1.4 nm

ALL-ASPECT: No

LOOKDOWN: Superior

MAX HIT PROBABILITY:50%

WARHEAD: 6 kg

LETHALITY: Low

AA-9 Amos

TYPE: Medium-Range Active Radar Missile

WEIGHT: 1,080 lbs

MAX SPEED: 2,500 kts

MIN/MAX RANGE: 0 - 41 nm

ALL-ASPECT: Yes

LOOKDOWN: Poor

MAX HIT PROBABILITY:50%

WARHEAD: 47 kg

LETHALITY: High

AA-10 Alamo

TYPE: Medium-Range SARH Missile

WEIGHT: 560 lbs

MAX SPEED: 2,500 kts

MIN/MAX RANGE: 0 - 19.7 nm

ALL-ASPECT: Yes

LOOKDOWN: Poor

MAX HIT PROBABILITY:50%

WARHEAD: 39 kg

LETHALITY: High

AA-11 Archer

TYPE: Medium-Range IR-Seeking Missile

WEIGHT: 230 lbs

MAX SPEED: 1,800 kts

MIN/MAX RANGE: 0 - 9.8 nm

ALL-ASPECT: No

LOOKDOWN: Superior

MAX HIT PROBABILITY: 75%

WARHEAD: 8 kg

LETHALITY: Low

AA-12 “AMRAAMSKI”

TYPE: Medium-Range Active Radar Missile

WEIGHT: 385 lbs

MAX SPEED: 2,100 kts

MIN/MAX RANGE: 0 - 24.6 nm

ALL-ASPECT: Yes

LOOKDOWN: Superior

MAX HIT PROBABILITY: 75%

WARHEAD: 30 kg

LETHALITY: High

Russian Air-to-Surface Missiles

AS-7 Kerry

TYPE: Short-Range Radar-Guided Missile

WEIGHT: 631 lbs

EFFECTIVE RANGE: 0 - 4.9 nm

MAX HIT PROBABILITY: 80%

WARHEAD: 110 kg

AS-14 Kedge

TYPE: Medium-Range Laser-Guided Missile

WEIGHT: 1,495 lbs

EFFECTIVE RANGE: 0 - 6.5 nm

MAX HIT PROBABILITY: 80%

WARHEAD: 330 kg

AS-16 Kickback

TYPE: Medium-Range Radar-Guided Missile

WEIGHT: 2,640 lbs

EFFECTIVE RANGE: 0 - 6.5 nm

MAX HIT PROBABILITY: 80%

WARHEAD: 330 kg

AT-2 Swatter

TYPE: Short-Range Command-Guided Missile

WEIGHT: 2,640 lbs

EFFECTIVE RANGE: 0 - 2.9 nm

MAX HIT PROBABILITY: 50%

WARHEAD: 330 kg

AT-12 Swinger

TYPE: Short-Range Laser-Guided Missile

WEIGHT: 132 lbs

EFFECTIVE RANGE: 0 - 4.2 nm

MAX HIT PROBABILITY: 80%

WARHEAD: 8 kg

NATO Air-to-Surface Missiles

AGM-65G Maverick

TYPE: Medium-Range IR-Seeking Missile

WEIGHT: 675 lbs

EFFECTIVE RANGE: 0 - 9.8 nm

MAX HIT PROBABILITY: 90%

WARHEAD: 136 kg

AGM-88 HARM

TYPE: Medium-Range Highspeed Anti-Radiation Missile

WEIGHT: 795 lbs

EFFECTIVE RANGE: 0 - 12.3 nm

MAX HIT PROBABILITY: 90%

WARHEAD: 66 kg

AGM-84A Harpoon

TYPE: Long-Range Active Radar Missile

WEIGHT: 1,165 lbs

EFFECTIVE RANGE: 0 - 59 nm

MAX HIT PROBABILITY: 90%

WARHEAD: 220 kg

AGM-84E SLAM

TYPE: Long-Range Active Radar Missile

WEIGHT: 1,380 lbs

EFFECTIVE RANGE: 0 - 49 nm

MAX HIT PROBABILITY: 90%

WARHEAD: 220 kg

NATO Surface-to-Air Missiles

ASROC

TYPE: Low to Medium Altitude SARH Missile

EFFECTIVE RANGE: 0 - 12.3 nm

EFFECTIVE ALTITUDE: 1,000 - 30,000 ft

ACCURACY: Medium

HOMING INTELLIGENCE: Average

WARHEAD: Unknown

LETHALITY: High

AIM-7 Sea Sparrow

TYPE: Low to Medium Altitude SARH Missile

EFFECTIVE RANGE: 0 - 12.3 nm

EFFECTIVE ALTITUDE: 1,000 - 30,000 ft

ACCURACY: Medium

HOMING INTELLIGENCE: Average

WARHEAD: 39 kg

LETHALITY: High

Russian Surface-to-Air Missiles

SA-3 Goa

TYPE: Low to Medium Altitude SARH Missile

EFFECTIVE RANGE: 1.2 - 8.9 nm

EFFECTIVE ALTITUDE: 5,000 - 36,000 ft

ACCURACY: Low

HOMING INTELLIGENCE: Average

WARHEAD: 60 kg

LETHALITY: High

SA-6 Gainful

TYPE: Low to Medium Altitude SARH Missile

EFFECTIVE RANGE: 1.4 - 12.3 nm

EFFECTIVE ALTITUDE: 2,000 - 30,000 ft

ACCURACY: Low

HOMING INTELLIGENCE: Average

WARHEAD: 56 kg

LETHALITY: Medium

SA-7 Grail

TYPE: Low Altitude Manportable IR-Seeking Missile

EFFECTIVE RANGE: 0 - 1.4 nm

EFFECTIVE ALTITUDE: 0 - 6,000 ft

ACCURACY: Low

HOMING INTELLIGENCE: Average

WARHEAD: 2 kg

LETHALITY: Low

SA-9 Gaskin

TYPE: Low Altitude IR-Seeking Missile

EFFECTIVE RANGE: 0 - 1.4 nm

EFFECTIVE ALTITUDE: 0 - 6,000 ft

ACCURACY: Low

HOMING INTELLIGENCE: Average

WARHEAD: 30 kg

LETHALITY: Low

SA-13 Gopher

TYPE: Low Altitude IR-Seeking Missile

EFFECTIVE RANGE: 0.25 - 2.4 nm

EFFECTIVE ALTITUDE: 100 - 10,000 ft

ACCURACY: Low

HOMING INTELLIGENCE: Average

WARHEAD: 2.7 kg

LETHALITY: Low

SA-14 Gremlin

TYPE: Low Altitude Manportable IR-Seeking Missile

EFFECTIVE RANGE: 0 - 2.4 nm

EFFECTIVE ALTITUDE: 0 - 15,000 ft

ACCURACY: Low

HOMING INTELLIGENCE: Superior

WARHEAD: 2 kg

LETHALITY: Low

SA-15 Gauntlet

TYPE: Low to Medium Altitude SARH Missile

EFFECTIVE RANGE: 0.1 - 5.9 nm

EFFECTIVE ALTITUDE: 100 - 18,000 ft

ACCURACY: Medium

HOMING INTELLIGENCE: Average

WARHEAD: 15 kg

LETHALITY: Medium

SA-16 Gimlet

TYPE: Low Altitude Manportable IR-Seeking Missile

EFFECTIVE RANGE: 0 - 2.4 nm

EFFECTIVE ALTITUDE: 0 - 15,000 ft

ACCURACY: Low

HOMING INTELLIGENCE: Superior

WARHEAD: 2 kg

LETHALITY: Low

SA-19

TYPE: Low Altitude SARH Missile

EFFECTIVE RANGE: 0 - 3.9 nm

EFFECTIVE ALTITUDE: 0 - 9,500 ft

ACCURACY: High

HOMING INTELLIGENCE: Average

WARHEAD: 10 kg

LETHALITY: Low

SA-N-3 Goblet

TYPE: Medium to High Altitude SARH Missile

EFFECTIVE RANGE: 0.8 - 16.5 nm

EFFECTIVE ALTITUDE: 1,000 - 75,000 ft

ACCURACY: Low

HOMING INTELLIGENCE: Average

WARHEAD: 80 kg

LETHALITY: High

SA-N-4 Gecko

TYPE: Low Altitude SARH Missile

EFFECTIVE RANGE: 0.6 - 5.7 nm

EFFECTIVE ALTITUDE: 500 - 15,000 ft

ACCURACY: Low

HOMING INTELLIGENCE: Average

WARHEAD: 40 kg

LETHALITY: High

SA-N-5 Grail

TYPE: Low Altitude IR-Seeking Missile

EFFECTIVE RANGE: 0 - 1.4 nm

EFFECTIVE ALTITUDE: 0 - 6,000 ft

ACCURACY: Low

HOMING INTELLIGENCE: Average

WARHEAD: 2 kg

LETHALITY: Low

SA-N-7 Gadfly

TYPE: Low to Medium Altitude SARH Missile

EFFECTIVE RANGE: 0.2 - 9.8 nm

EFFECTIVE ALTITUDE: 500 - 45,000 ft

ACCURACY: Low

HOMING INTELLIGENCE: Average

WARHEAD: 70 kg

LETHALITY: Medium

SA-N-8 Gremlin

TYPE: Low Altitude IR-Seeking Missile

EFFECTIVE RANGE: 0 - 2.5 nm

EFFECTIVE ALTITUDE: 0 - 10,000 ft

ACCURACY: Low

HOMING INTELLIGENCE: Superior

WARHEAD: 2 kg

LETHALITY: Low

SA-N-9 Klinok

TYPE: Low Altitude IR-Seeking Missile

EFFECTIVE RANGE: 0.2 - 5.9 nm

EFFECTIVE ALTITUDE: 0 - 18,000 ft

ACCURACY: Medium

HOMING INTELLIGENCE: Average

WARHEAD: 15 kg

LETHALITY: Medium

SA-N-11 Gremlin

TYPE: Low to Medium Altitude SARH Missile

EFFECTIVE RANGE: 0.2 - 3.9 nm

EFFECTIVE ALTITUDE: 100 - 24,000 ft

ACCURACY: Medium

HOMING INTELLIGENCE: Average

WARHEAD: 10 kg

LETHALITY: Medium

Bombs

Mk 82

TYPE: General Purpose Glide Bomb

WEIGHT: 500 lbs

WARHEAD: 87 kg

Mk 84

TYPE: General Purpose Glide Bomb

WEIGHT: 2,000 lbs

WARHEAD: 348 kg

GBU-10 Paveway

TYPE: Laser-Guided Glide Bomb

WEIGHT: 2,000 lbs

WARHEAD: 348 kg