

GALACTIC

EMPIRE

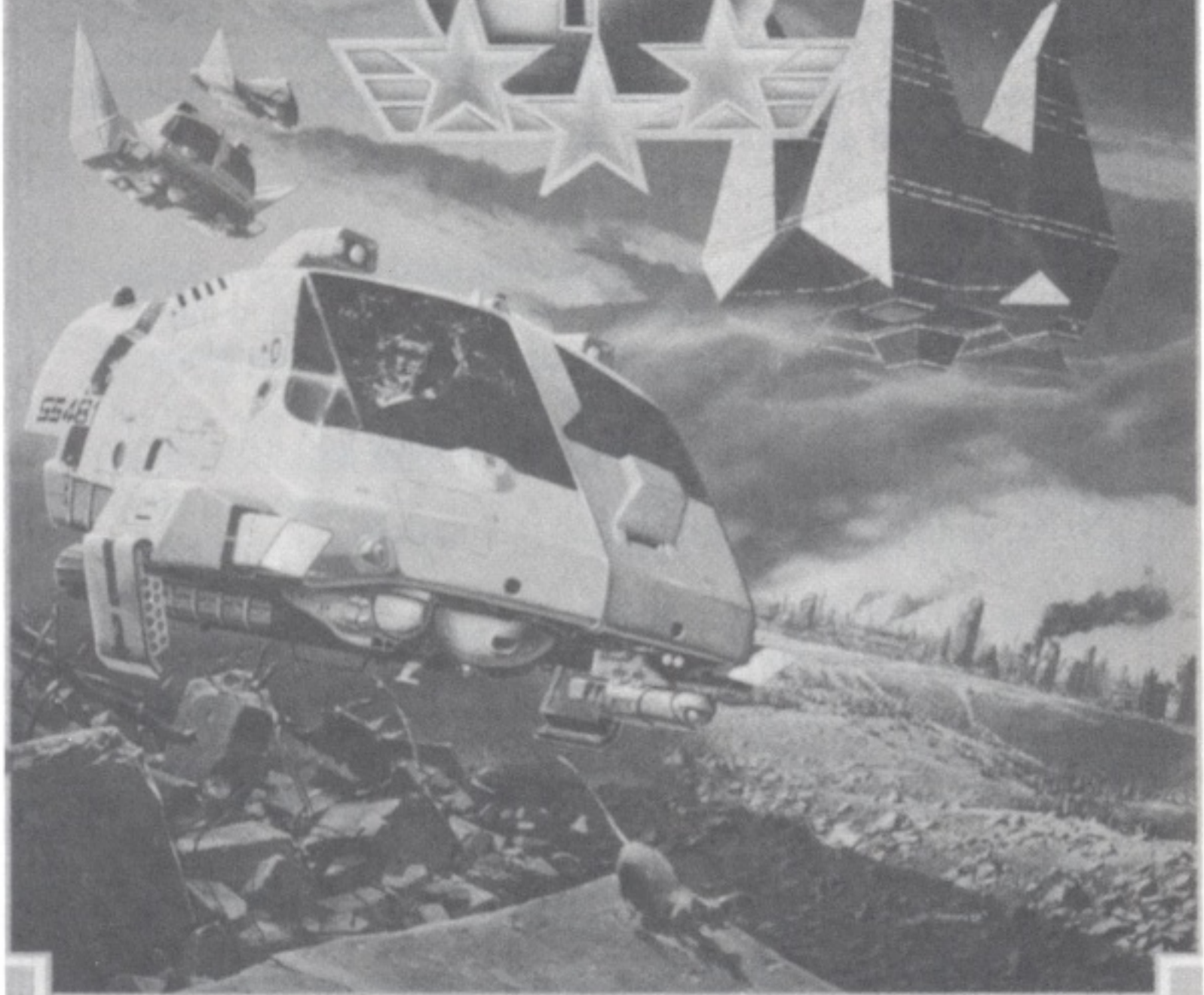

T  
O  
M



A H A W K

## **RAPID START UP PROCEDURE**

If you are familiar with using a computer the RAPID START UP PROCEDURE will be enough to get you started. If you need further explanations, consult at the end of the booklet the DETAILED START UP PROCEDURE which contains advice on use, step-by-step instructions for start up and the installation of the software on your hard disk.

### **IMPORTANT**

This software is distributed with a color card which serves as an anti-piracy protection device. Identify it by typing in the name of your program. Keep this document in a safe place, it will be necessary at each start up.

Make a copy of the program. By using a copy you avoid any risk of damaging the original.

Do not write protect your diskettes during use.

### **On the ATARI ST and AMIGA**

- 1 - Insert diskette number 1.
- 2 - Switch on the computer or reboot it. The software will automatically load itself.
- 3 - Complete the protection test described in paragraph X - 2.

### **On the IBM PC and compatibles**

- 1 - Switch on the computer or reboot it.
- 2 - Insert diskette number 1.
- 3 - Type GO, then press the Return or Enter key.
- 4 - Indicate the type of graphics card your machine has.
- 5 - Indicate the type of mouse you have.
- 6 - Indicate the type of sound required.
- 7 - Complete the protection test described in paragraph X - 2.

# ETHER FILE

**Origin:** SERSEC permanent office  
**Galactic Secto :** 841 106B  
**Confidentiality:** ORANGE  
**Addressee:** Special agent on Ether

## GENERAL INFORMATION ABOUT THE ETHER SYSTEM

The Ether system consists of 3 planets which gravitate around a white-blue sun type A.

The planet nearest the sun is a burnt planetoid of no interest at all.

The third planet is a Jovian type gaseous giant furnished with a crown of rings. Thanks to the K-Ether imperial station, it supplies hydrogen to the system.

The second planet has been colonized for four centuries under the name of Ether. This vast planet has crushingly heavy gravity while its atmosphere, excessively rich in carbon gas and the enormous heat of its climate, prevent human colonization but generated the unique presence in the empire of its fauna with their outstanding properties.

## GEOGRAPHICAL OUTLINE

The equatorial diameter of Ether is 30,000 km. Its gravity, 10 g is impossible for humans to tolerate without total control of anti-gravity. Normally, for instance to make the most of a mining resource, the colonizing empire would have terraformed to the planet by installing anti-gravitational suspension devices on orbit, then triggering skillful chemical reactions in the higher atmosphere and finally by ensuring the massive implantation of chlorophyll ultra-fast growing plants. After a century or two, the planet would have benefited from atmospheric conditions and a climate adapted to human life.

But Ether's wealth came from its fauna which obviously could not survive such a modification of its living conditions. Therefore, the Etherian colonists had to put up with a life confined to the interior of the anti-grav formecs, a reconstituted atmosphere and pre-fabricated residences.

The average temperature on the surface of Ether is 450° Centigrade. It varies according to the latitude, altitude and times of the day. It is subject to extremely localized sulfuric acid storms which devastate the scarce vegetation. Essentially the planet is made up of arid and volcanic deserts. Vast expanse of vitrified lava interspersed with basalt blocks give its landscapes a dreary impression of sadness and desolation.

According to the report by the ecological architects Smanir, chief of the first imperial expedition to Ether, there are no present or past traces of intelligent life on the planet.

## **THE FLORA**

The Etherian vegetation has the particularity of moving. This vegetal nomadism is a need to get away from the stripping acid showers. However, unlike the fauna, the flora is extremely hardy and enjoys remarkable longevity. During the seasons when the atmosphere becomes too opaque to allow the white stars rays through, the flora becomes almost sedentary and attacks other plants and even animals. To do this, it has developed surprising traps and camouflage techniques.

## **THE FAUNA**

The animals populating the surface of Ether have outstanding fertility but a relatively short life span. A few hours at most. This does not prevent them from quickly reaching impressive sizes. They have even been compared with the giant reptiles of the pre-historic past of the Earth or with the dragons of ancient legends. Generally, the animals are bipeds. They move by walking or leaping some have ridiculously small wings. These shrunken appendages skill enable them to fly in spite of the gravity. Their flights are relatively short but are probable due to the extraordinarily light bond structure of all the living beings and by the almost palpable density of the atmosphere.



SOME TYPES OF ETHER ANIMALS

Their greatest originality is their method of reproduction. It is unique in the galaxy because in contradiction to the customarily laws of biology, everything takes place as if animals of different species were to have the possibility of reproducing with one another.

The genetic particularity of interspecies reproduction in the Etherian faun has not yet been given any faultless scientific explanation. Because these are very different species as is abundantly proven by the observations and dissections carried out. The only point in common between parents and the fruit of their love-making is generally the form of the head and the type of defense. This has lead some imperial exobiologists to put forward the hypothesis that a small number of animal families are characterized by the head alone and that the body and means of displacement would vary for reasons which have not yet been illuminated (climate, type of land, etc?).

In any case, this extreme adaptability endows the muscular tissue of the representative of the Etherian faun with incomparable and extremely coveted qualities in medicine. In particular for problems of rejected organ graphs. The addition of Etherian tissue extracts offers a spectacular increase to the tolerance of the graphs. But these animal extracts are also used for every different aliment due to changes of plants (climate,

atmosphere, gravity, etc.). In addition, their endocrine glands secrete a substance which is extremely difficult to obtain synthetically and which enters into the composition of peredine, the secret drug for eternal youth. That is just how important the plant is in imperial economy. It is led to the arrival of many hunters on Ether. Attempts to raise Etherian fauna in captivity has been made but these ferocious animals which spend their time copulating and killing one another is enough to discourage the most ardent of breeders.

Indeed, all the Etherian animals are carnivorous with an almost insatiable appetite. If we believe the tales told by Etherian hunters, this particularity makes it possible to capture the fiercest elements by baiting them with the leftovers of previously killed animals. But these highly colored tales are worth considering with some caution. Similarly, the story told about the birth of small animals which have mutated with respect to their parents are doubtful too. It is said that these ungrateful offspring have the barbarous custom of killing their parents as of their birth. All these points should be verified on the spot because all attempts made to import animals into imperial zoos have failed.

The final particularity of Etherian animals (and not the least for galactic smugglers), is the sophistication of their defensive weapons which have generated a great deal of clandestine traffic. The best known are the arachno suc, a glutinous liquid which immobilizes the adversary. The extremely toxic fluo gas has a molecular composition so fine that it will pass through the thickest armor; the venomous dods are weapons which are undetectable during autopsy, an excellent tool for the guild of assassins while spherogels are bowls of carbonic gas a temperature so low that they freeze the object or being against which they are thrown.

## THE POLITICAL SITUATION

Apart from the K-Ether imperial station mentioned above, the second planet of the system was colonized in the 112th century. The colonized area was equatorial, the area least propitious to technical upheavals. The main cities are the capital, Tiph-Eher located not far from the Harbounge intergalactic airport and the Tekno Dsehe city.

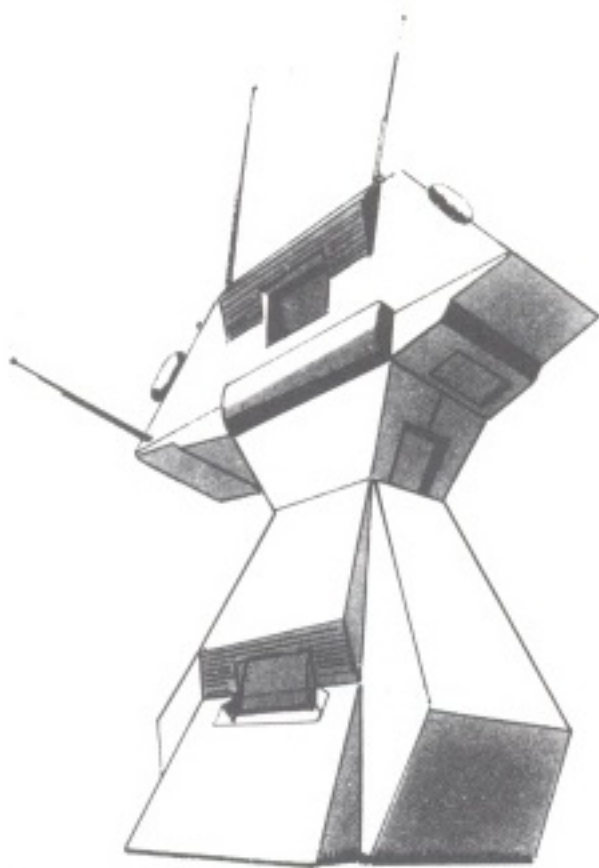

ROBOT

The remainder of the planet is hardly colonized at all although wandering hunters are often encountered there. The planet's population consists mainly of scientific and adventurers. Most of the colonials are humans from the surrounding imperial systems. A minority of non-human worker (Graafs, Melkions, etc.) has also set up here. The difficulties of local life (see above), the absolute need to live confined in protection modules make this planet particularly underpopulated and unsuitable for tourism. There are also many robots used by the

Teknos for heavy tasks.

Three years ago a hunter named Voltar began to generate anti-imperial trouble. On the basis of racism and the growing economic crisis in the field of raw materials for medicinal purposes, he soon found a good number of partisans who joined him under the name of "scarlet militia".

Benefiting from the traditional individualism of hunters and the equally traditionally indifference of the Teknos with respect to politics, he generated trouble, spread terror throughout the non-

human colonials and began to take over power in the colony.

Today it seems impossible that Voltar found the support of a fair half of the population for a policy against the empire which would be eventually suicidal for the planet. He declared that "imperialist exploitation is over". (sic) while proclaiming the succession of the Etherian system. But the Etherians depend entirely upon the exchanges with the outside because they live on a hostile planet where the essential raw materials for life are scarce and difficult to obtain. Further, the weak local industries

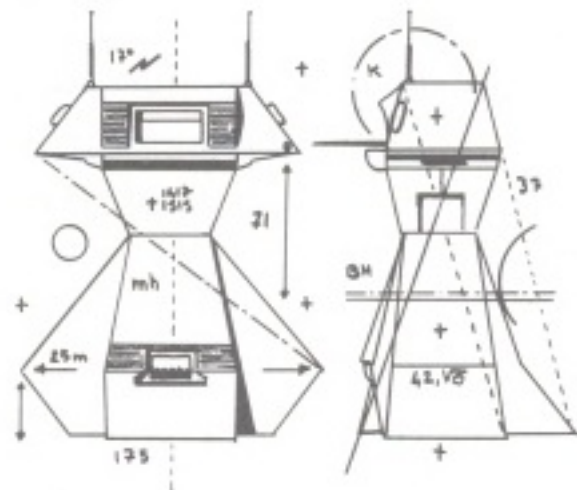

and skills to use them are in the hands of the Tekno faction, mainly hostile to the new regime. La Hanse des Marchands, faithful to imperial traditions is alone in being able to export and commercialize the planets products. Showing outstanding unrealism for such a pragmatic people, the Etherian hunters are following him in great numbers.

Confronted by such an extremist attitude, voices have been raised within the local population. Voltar then organized a bloody repression of his opponents. He turned the "scarlet militia" into an pitiless and absolute dictatorial power.

According to the report of the SERSEC officer on the spot, Voltar has even opened internment camps on Ether. The brutal disappearance of this officer cutoff all our ties with the planet.

It is more than probable, and on the basis of information gathered among different sources, a full scale civil war is taking place at this time on the planet. The Teknos can be counted upon to fight the "scarlet militias" which hold Tiph-Ether, the capital and Harbouge, the astroport. But it would appear that the Teknos are divided into rival factions. The merchants are neutral as long as the dictator does not foil their interests. The non-humans of the colony are also opposed to Voltar who has used them as his stooges. But they had no know structured organization at the time when our agent disappeared. Most of the hunters are members of the "scarlet militias" but not all of them. In short, the planet is in a state of chaos.

It is fundamental for SERSEC to send you as on the spot investigator to evaluate the situation. You have to get in touch with elements hostile to the dictator and which are therefore favorable to the empire, evaluate their strength and the means they might need to overthrow the regime. In addition this anti-imperial policy is so totally against local interests that their is a question of whether the situation is not being manipulated by an unknown enemy. We have no information for the time being which enables us to confirm or refer to this hypothesis.

As things stand now, the policy of the Empire and the guilds has not yet

been determined in its entirety. The supreme council is looking at the situation. There are three apparent trends being put forward. The first, obviously with the support of the army, is for local intervention of a cohort of Scorpionauts, backed by the intervention division. Another in favor of the Teknos, is more specifically for an economic embargo. The third, that of la Hanse, prefers to wait until combat is over to negotiate with the winner. That gives you an idea of how urgent the report from our services has become.

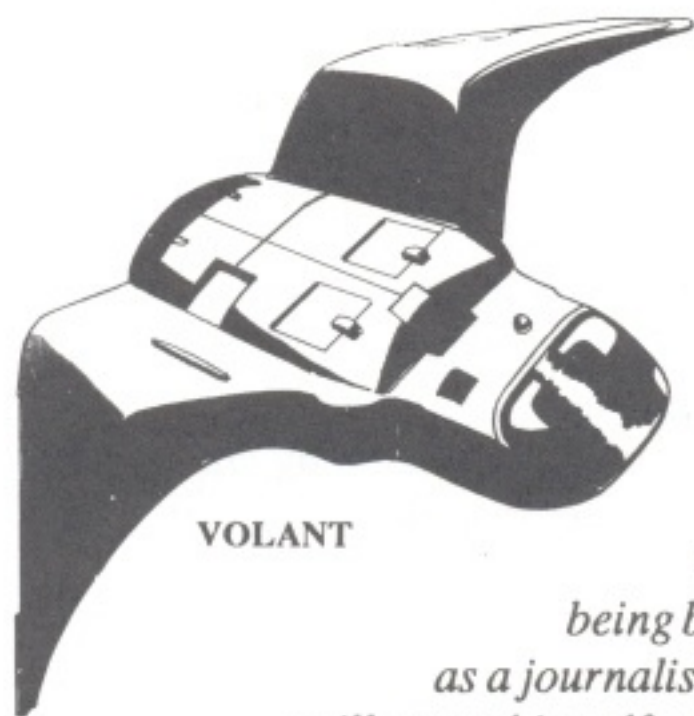

VOLANT

*Last minute: according to information from la Hanse des Marchands, the two main cities on Ether, Tiph-Ether and Dsehe, the Tekno city, are the scene for violent combat. They are riddled with traps rendering the progression of our agent extremely difficult. The Harbouge astroport is still open to inter-galactic traffic for the time being but that is not likely to last. Coverage as a journalist must be obtained for our agent. He will pass himself off as a war correspondent for the homeo-newspaper, Cosmopolis. Beware: do not supply him with any material which might identify him as an imperial agent. The last words of our officer on Ether were: "It's the Malkouts fault." He was talking about the secret causes of the civil war. It is essential that our agent discovers the meaning of this phrase.*

## EQUIPMENT

### TECHNOLOGICAL EVALUATION

According to the galactical criteria, Ether is considered to be a world at technological level 5, slightly below the imperial maximum. But is war continued, or if the planet was isolated by an embargo, this level might drop quickly.

## ARCHITECTURE

On Ether, human life is confined to the interior of the formecs. These are Etherian constructions unique to the planet. They are more like store rooms or bunkers to provide protection during periods of rest. All the buildings are made of plastasteel, a cheap and practically indestructible material.

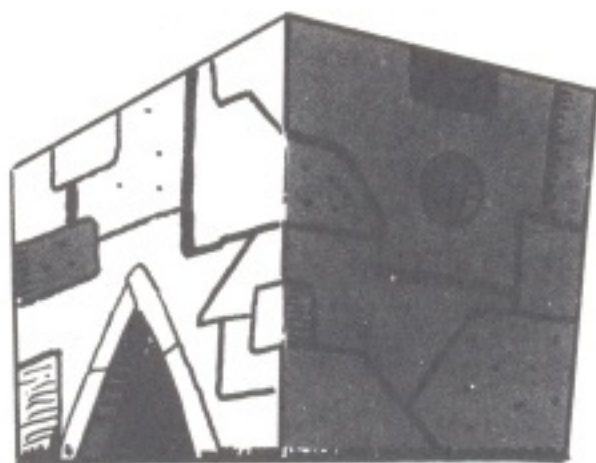

BUILDING

## THE "FORMECS"

Originally the formec (from mechanical force) is a robotized combat armor. Developed by the navyborg guild, these machines provide protection and sustain life (providing water, food, various contingencies, etc) without direct action by the user. Propelled by anti-gravity, they are adapted to every environment, compatible with every condition, from space vacuum to the sulfuric acid swamps of Ether.

For combat, Etherian formecs are relatively reliable but most of the animals recorded on Ether (except for unlisted mutations) have weapons capable of piercing the toughest armor.

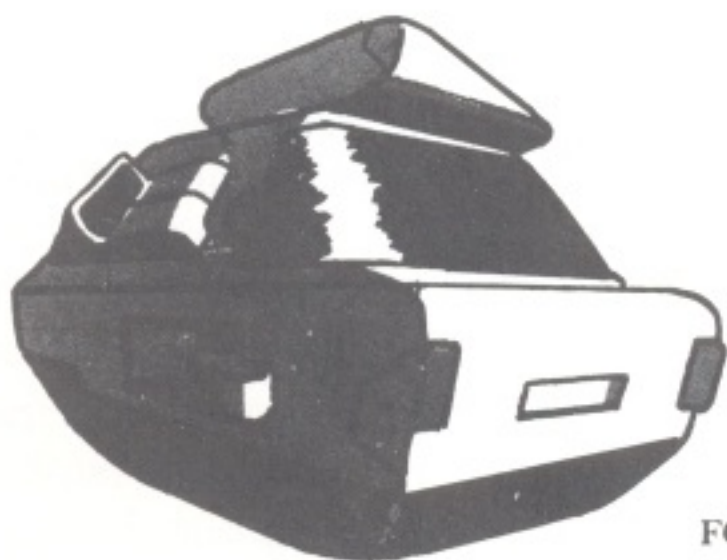

FORMEC

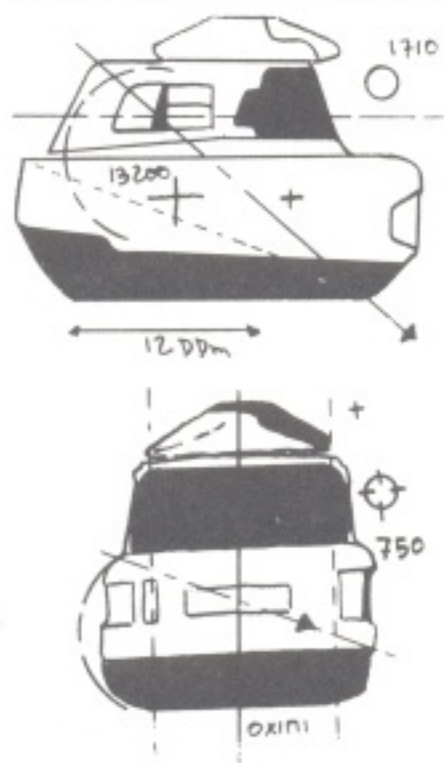

The state of the oxygen levels must be checked regularly and the interior temperature monitored at all time.

## AIR CONDITIONING

It is possible to obtain conditioned air modules on the spot. These are simple heat planification units which absorb excessively high temperatures or, conversely, heat the atmosphere when it is too cold.

## TRACTOR OR REPULSER FIELDS.

These gravity field inducting or inverting elements are the principle part of anti-gravity motors. Our reports indicate that some were diverted from their purpose to serve as traps.

## OXYGEN

Oxygen consumption is mandatory on the planet. Oxygen appears in the form of blue spheres which can be obtained easily from special dispensers.



## REFILL

Universal refill is a way of transferring hydrogen into the formec fusion cell. No radioactivity is produced during the fusion operation which only generates a small amount of residual helium. Once refilled, the fusion cell makes it possible to use all the weapons mounted on the Formec.

## ARMOR

Many sorts of armor are available on Ether. Of course there are energy screens which when activated protect the formec. But most of them are specific. Therefore, they only provide effective protection against a single particular type of weapon. When confronted by a weapon for which they are not designed, these screens break down gradually. Accordingly, it is essential to predict the type of weapons liable to be used and activate the appropriate armor. Unfortunately, this report cannot give details of all the possible interactions of weapons and armors. (see page 12).

# ARMOR

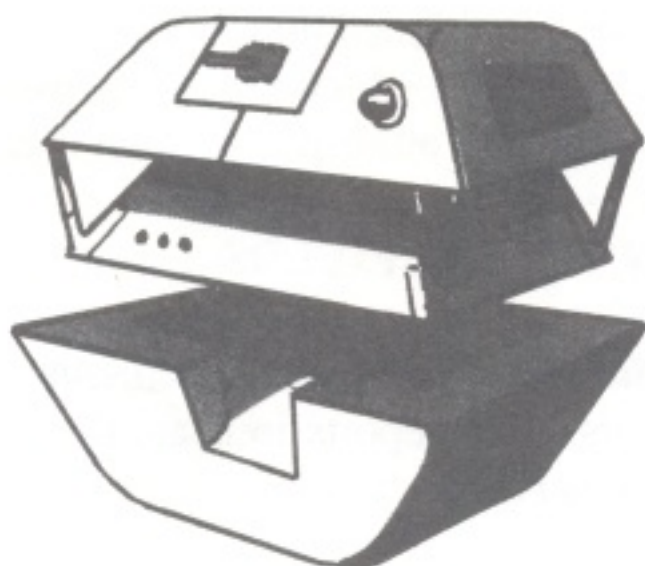

ANTI-GAS SCREEN

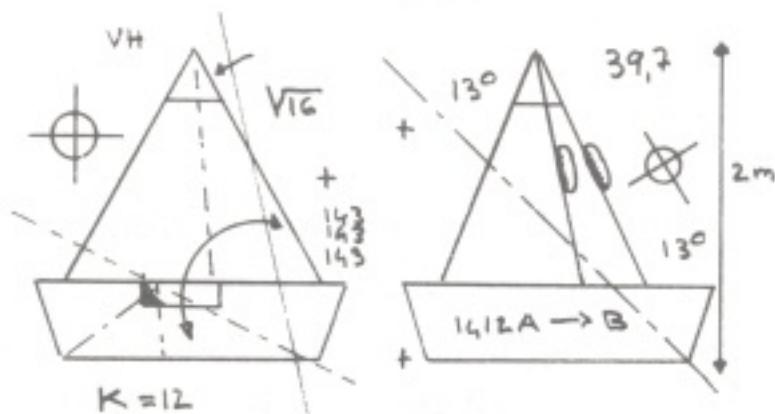
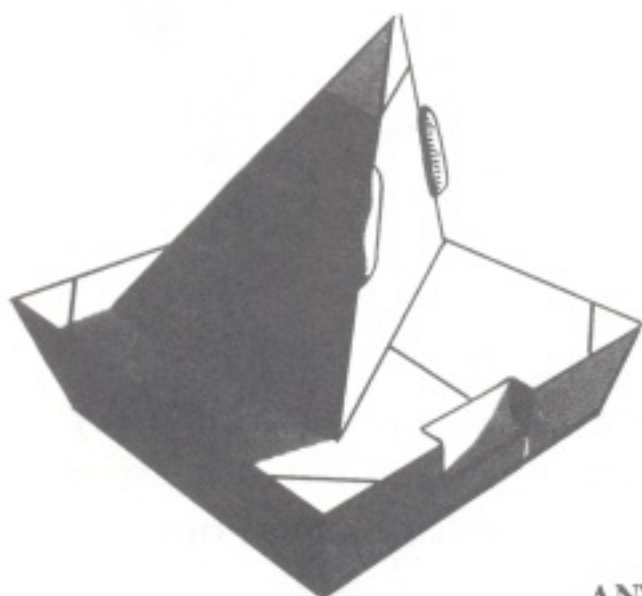

ANTI-BLAST SCREEN

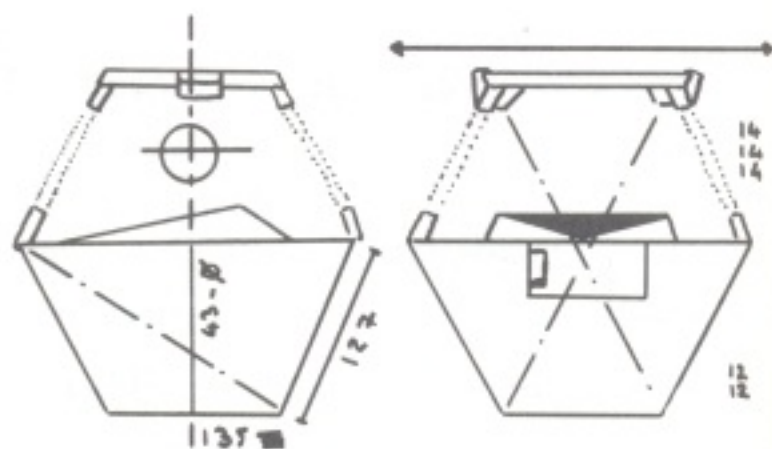
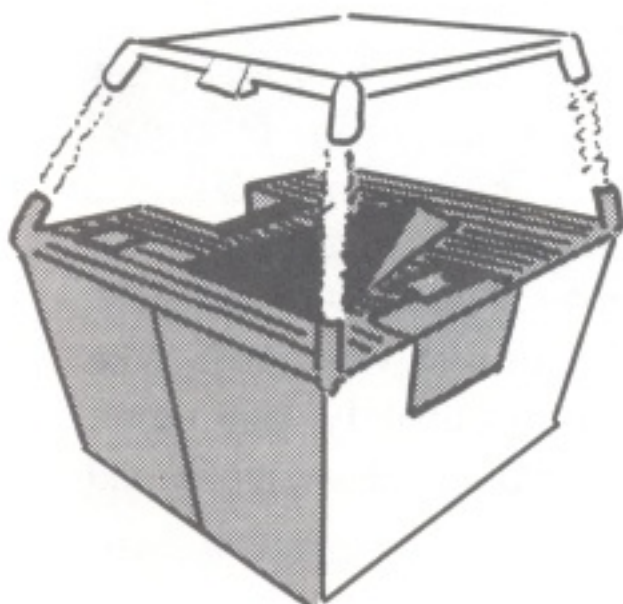

LASER SCREEN

## RADARS

Most types of combat radars exist on Ether: wall radars, animal detectors, live being detectors, projectile detectors, etc. They are specific and cannot be accumulated with one another at the same time. They denote the precise presence and position of a certain type of object with respect to the user who is always at the screen center.

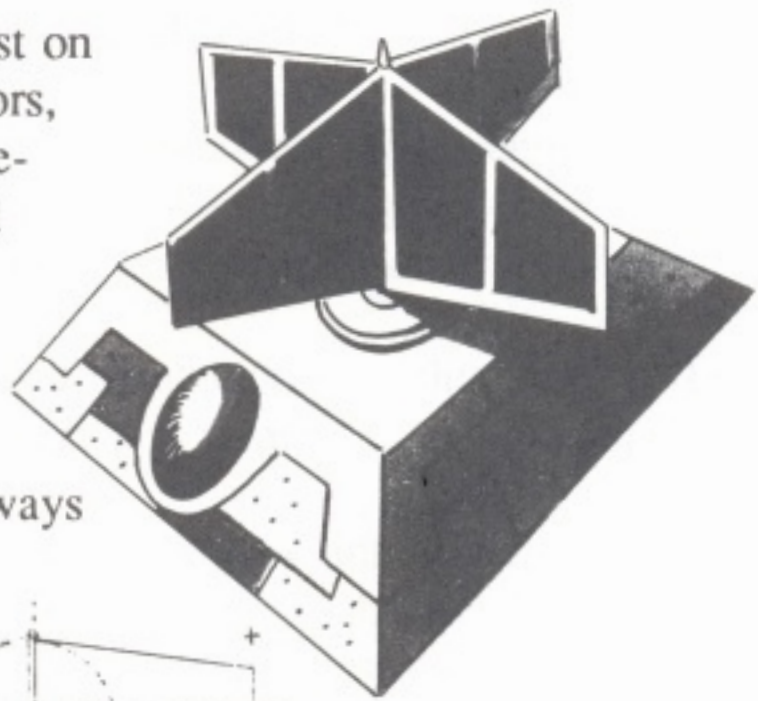

RADAR

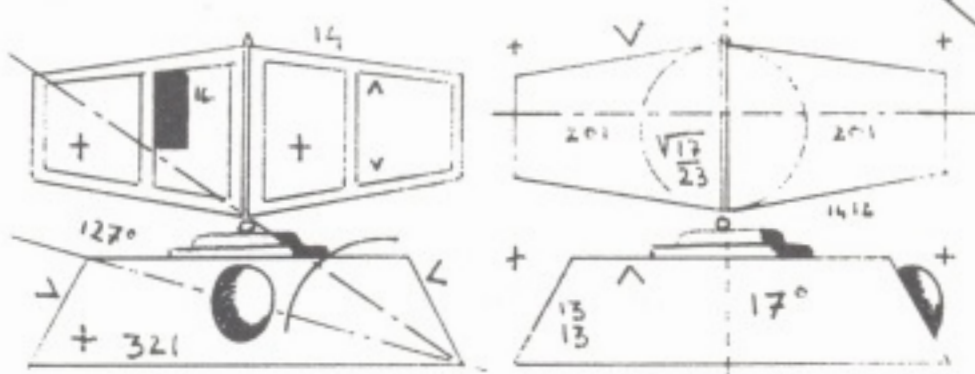

## TRACER

Beware! On Ether you might come across tracers which when mounted on a formec allow it to be followed on a special radar. Our agent must keep a close eye on this danger of being identified! It could compromise the success of his assignment.

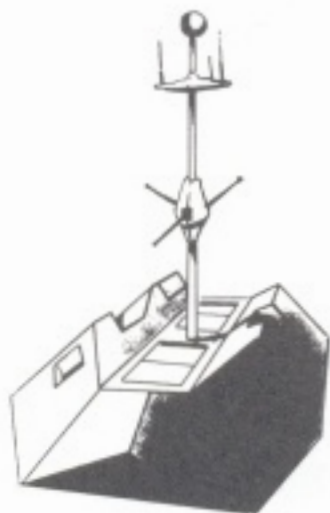

TRACER

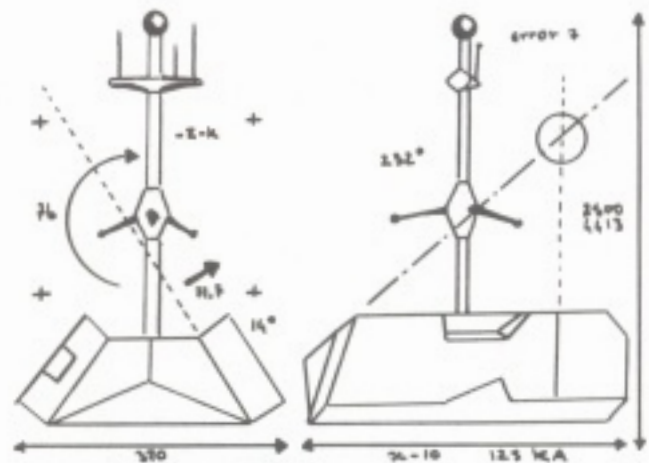

## WEAPONS

Many weapons are employed in this civil war. Perusal of all the reports enables the following list to be drawn up but it is perhaps not exhaustive:

- **Spherogel:** this weapon is used for launching a sphere of carbonic gas at a very low temperature which temporarily freezes the target it hits. It is derived from a weapon used naturally but Etherian animals.

- **Dart gun:** this weapon sends microscopic and self guided poison darts into the body of an animal or into a formec.

- **Gas projector:** this weapon sends concentrated packets of combat fluo gas (gland extract of an Etherian animal). This gas is capable of penetrating the formecs and replacing all the oxygen they contain.

- **Arachnopistol:** this anti-riot weapon is used throughout the Empire. It is indigenous to Ether. This viscus suc is to be found in the natural state. It draws out into thin filaments to immobilize the being or object it hits.

- **Fusion Gun:** this weapon launches very high temperature plasma balls.

- **Flame-thrower:** this weapon throws a napalm flame over distances of several tens of meters.

- **Grenades:** these atomic mini-grenades are extremely dangerous. They are capable of piercing the most sophisticated anti-shock screens.

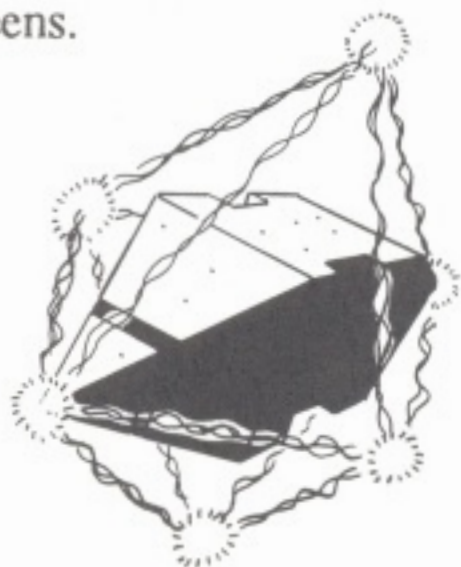

- **Mines:** static versions of the atomic grenades capable of activating and exploding on any kind of contact.

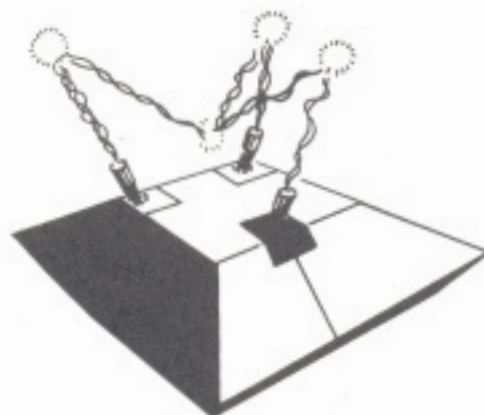



- **Light-heavy laser:** using the coherent radiation of light, this weapon can pierce the thickest armor.

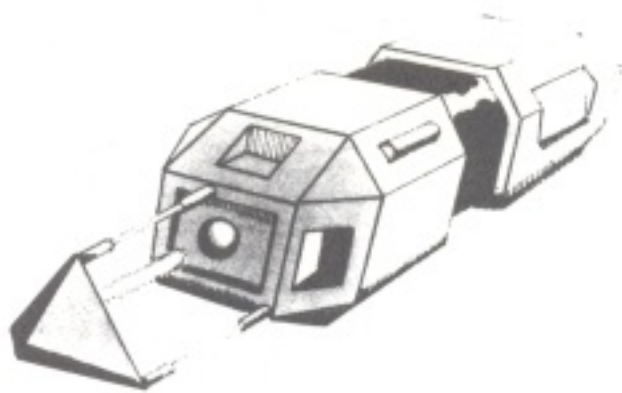

LIGHT LASER

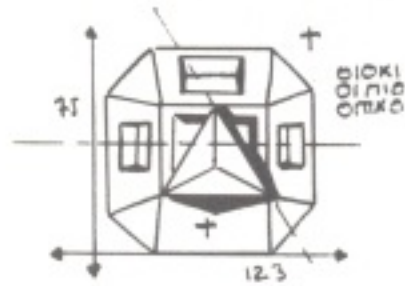
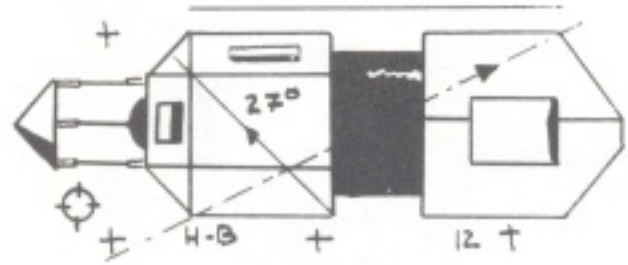

## PSYCHO

Positronic alpha wave generators, commonly called psychos, have been located within the Etherian system. They partially modify the normal behavior of a being and therefore influence his will. Our agent should get hold of one for himself.

## FORCE FIELD

The use of a force of field provides protection from almost all sorts of weapons. But it cannot move and is easy to locate. Only to be used in an emergency.

## DARC

The darc, Cybernetic Anti-Robot Disrupter temporarily jams the cognitive perceptions of robots.

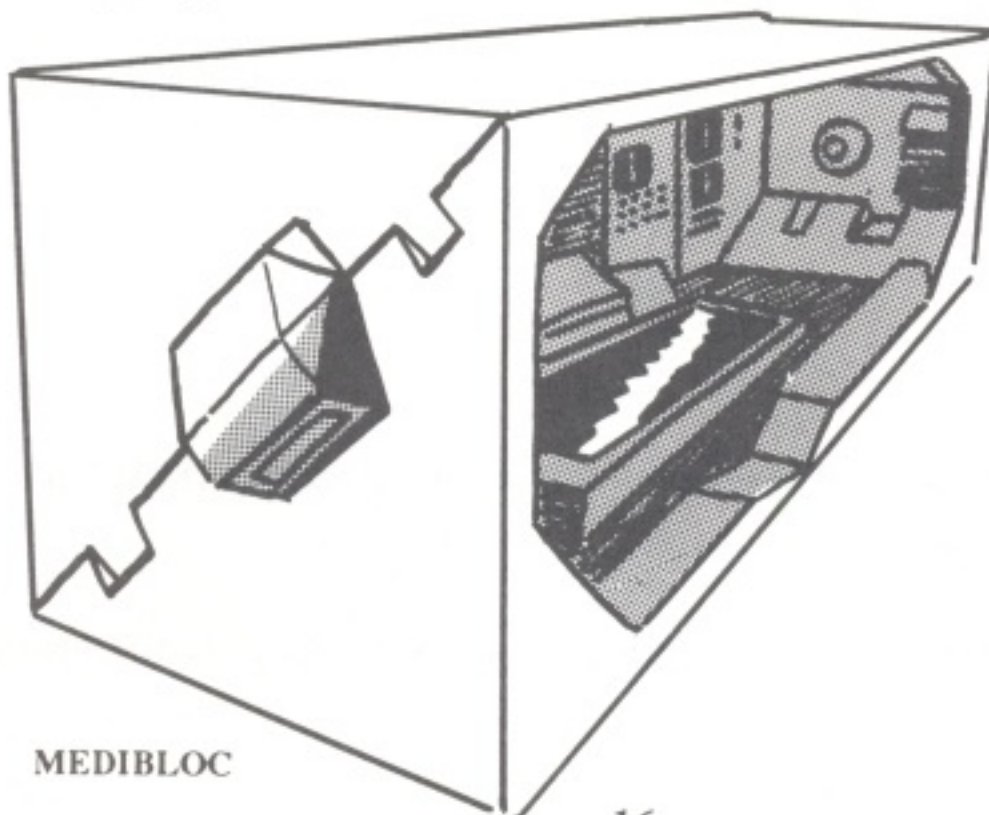

MEDIBLOC

**MEDIBLOC**  
There are several "medibloc" stations on the planet. They are designed to repair and optimize the performance of the formecs.

## CONTROL PANEL

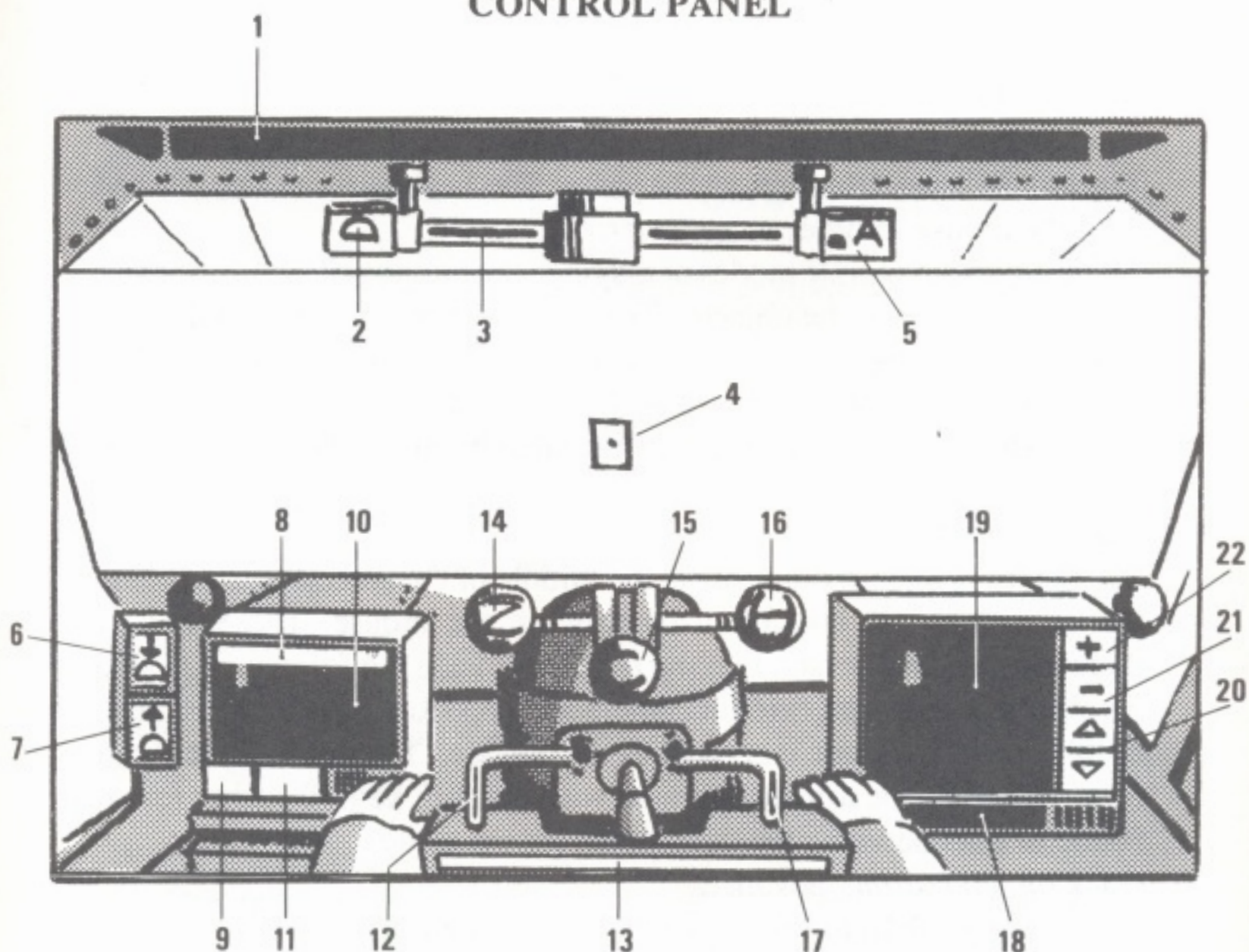

- |                               |                                 |
|-------------------------------|---------------------------------|
| 1 = Communication window      | 12 = Heat counter               |
| 2 = Armor inventory           | 13 = Energy counter             |
| 3 = Armor counter             | 14 = Idle                       |
| 4 = Movement sight            | 15 = Communication (Dialogue)   |
| 5 = Armor activation          | 16 = Help menu                  |
| 6 = Put object into inventory | 17 = Oxygen counter             |
| 7 = Put an object outside     | 18 = Compass                    |
| 8 = Ammunition counter        | 19 = Radars                     |
| 9 = Weapon inventory          | 20 = Access to different radars |
| 10 = Control screen           | 21 = Decrease precision         |
| 11 = Object inventory         | 22 = Increase precision         |

## COMMANDS

### USING THE MOUSE

The mouse is used throughout the game. The keyboard can also be used with the mouse in order to go faster.

There are two principle modes of playing: the moving of the formec and the management of the objects. The player alternates between the two modes by clicking on the right hand button of the mouse. On the other hand, the left button validates the choices made.

The mode being used is always identifiable by the shape of the cursor.

#### **“Move” mode**

The cursor is an immobile site at the middle of the screen. Movements of the formec are controlled by moving the mouse. The vision is therefore that of a person looking out from inside the formec. It is also possible to connect an exterior camera and press key B on the keyboard. In this case the formec is seen from the outside. The point of view can be modified by the arrows operated with the shift key. Whether for an inside or outside view, the commands are the same:

*Click on left button:* advance

*Move the mouse to the right or left:* turn to the right or left

*Click the right button:* exit from the “move” mode and change to the “enter” mode

#### **“Enter” mode**

The formec stays still. The cursor can be moved anywhere on the screen using the mouse. The cursor activates the icons or grabs or activates the objects. Beware! The results obtained changes with the cursor: if the hand is empty, normally, the cursor is a sort of electron. When an object is activated, the cursor becomes a two-color sight when used with a weapon; in the case of an object that transforms into a metallic sight. **The electron cursor (normal):** *click on the left button* = grab an object, select an icon, activate the object of the control screen or elsewhere in the world, select an option from the menu, open a door, select a go-between etc.

**Sight cursor (fire):** *click the left button* = use the weapon activated in

the control screen against the object on which we click.

**Metal cursor (object):** *click the left button* = use the object activated in the control screen on another object in the world. Eg: use a card for an energy barrier.

The three cursors (electron, two-color or metallic) provided access to the icons or to the menus.

In all cases: *clicking on the right button* - exit from the "enter" mode and change to the "move" mode.

## KEYBOARD COMMANDS

### On the digital key pad

+ = advance

- = move back

Keys 6 and 4: turn to right/left

Keys 6 and 4 + CONTROL : move sideways

Keys 1 and 3: change of focal length

Keys 8 and 2: look up/down

### Without a mouse

ENTER or RETURN = select the object or icon under the cursor

ESC = change cursors (move/enter mode) or printout the inventories

### Keyboard keys:

B = \_\_\_\_\_ switch from interior view to exterior view ( will not operate inside the buildings)

Up/Down/Right/Left Arrows \_\_\_\_\_ move the camera for an exterior view

+, - with the shift key = \_\_\_\_\_ move the camera in and out

Z = \_\_\_\_\_ idle

C = \_\_\_\_\_ dialogue

H = \_\_\_\_\_ access to menus

N + CONTROL (CTL) = \_\_\_\_\_ new game

L + CONTROL (CTL) = \_\_\_\_\_ load a saved game

S + CONTROL (CTL) = \_\_\_\_\_ load a game

Q + CONTROL (CTL) = \_\_\_\_\_ quit

- P + CONTROL (CTL) = \_\_\_\_\_ pause  
 H + CONTROL (CTL) = \_\_\_\_\_ help (description of screen)  
 O + CONTROL (CTL) = \_\_\_\_\_ options  
 F1 = \_\_\_\_\_ put an object into the inventory  
 F2 = \_\_\_\_\_ move an object outside  
 F3 = \_\_\_\_\_ activate/deactivate an object  
 F4 = \_\_\_\_\_ weapon inventory  
 F5 = \_\_\_\_\_ object inventory  
 F6 = \_\_\_\_\_ increase the radar accuracy  
 F7 = \_\_\_\_\_ decrease the radar accuracy  
 F8 = \_\_\_\_\_ change radars  
 F9 = \_\_\_\_\_ armor inventory  
 F10 = \_\_\_\_\_ activate the armor

## USE OF ICONS

### Communication window

This is the place where your formec on board computer communicates with you. Explanatory text appear about the world which surrounds you. Short messages can also be displayed. These can be messages from your computer such as "No more oxygen" or "Go between not selected". If the messages is in capital letters "PROHIBITED ZONE", this is an external message linked with the zone or an object. The message is sent to you via your on board computer. Sometimes the sentence is a question "Do you want to enter? O/N". You must answer: O for O.K., N for no.

### Management of objects

#### *1/ Grabbing and object*

To grab an object on the outside, simply put the cursor into the "entry" mode by clicking the right hand button of the mouse, moving it onto the object and clicking on the left hand button of the mouse. The cursor then becomes a miniature view of the object.

Then move it onto icon 6 which sends it directly into the inventory corresponding to the type of object picked up. It can also be put down directly on the control screen (10). In this case it takes the place of the previously chosen object.

## *2/ Discarding an object*

To get rid of an object, first select it in the inventory so that it appears on the control screen (10). Then click with the left button on icon 7. The object is thrown outside of your formec.

## *3/ Select an object*

There are 3 inventories in which the objects collected in the world are stored automatically.

a) weapons inventory: this contains every sort of weapon. To gain access to the inventory click on icon 9.

b) object inventory: this contains all the basic objects like keys, oxygen reserves, energy reserves, etc. To gain access to the inventory, click on icon 11.

c) armor inventory: this inventory contains all the energy screens. To gain access to it, click on icon 2.

To select an object from the inventory, simply move the cursor onto the chosen object. The name of the object appears in the communication window. The object is located off the screen.

When you gain access to the inventory, just move the cursor towards it. The screen will scroll automatically so that you can reach that object. Once the cursor has been positioned, select the object by clicking on the left or right button of the mouse. If the cursor is not positioned on an object, exit from the inventory without first selecting the object.

## *4/ Activate an object*

To use an object, it must be activated. If the object is on the control screen (10), simply click using the left button of the mouse. The screen then turns red and the cursor changes shapes. Some objects operates automatically as soon as they are activated; the oxygen spheres or the conditioned air work like this. For others such as keys, weapons, etc., you must go and click on the object aimed at in the world, door, target, etc., with the new cursor.

## *5/ Special objects*

- **Radars:** the radars do not appear in an inventory. They are selected directly on the radar screen (key 20). The radars name appears in the communication window at the time of the selection. The radar is activated automatically as soon as one has been selected. It can operate constantly or just when the formec is at a stop. Chose its option from the "options" menu. Note that if the radar is operating constantly on a large

scale the game can slow down.

- **Armor:** once selected the armor does not appear in the control screen. However, a counter lights up at the top of the screen (3) indicating the charge of the armor. To activate the chosen armor, click on icon 5. Beware! If the weapon used against the armor is not the one it is protecting, the screen will gradually lose its charge and become unusable.
- **Mines:** mines are used like other objects (entry, inventory, activations, etc). But an activated mine (recognized by the flashing of its sensors) can be put in the outside world. Anything moving near and activated mine will fall when it explodes. This includes you if you move too close.
- **Weapons:** a charge counter (8) above the control screen indicates how much energy is being used up by a weapon. If it is empty, the weapon becomes useless. Recharging is available in the outside world to bring this counter back up.

## MENUS

Click on icon 16 to gain access to the help menu which includes a great number of possibilities. Access to the menu is also possible by hitting H on the keyboard.

### **New N + CTL**

This choice restarts a new game from the beginning.

### **Load L + CTL**

This choice loads a previously saved game. Put the back-up floppy disc into the disc drive and select the number of the desired game.

### **Save S + CTL**

This saves the game in progress. Put a previously formatted floppy disc into the disc drive. You can save up to 8 different games ( 5 on a 360 K floppy disk).

### **Quit Q = CTL**

Quit is an option for leaving a game without saving it.

### **Pause P + CTL**

This choice puts the game on hold.

### **Help H + CTL**

This choice gives access to comments on the game screen. Use the right

button of the mouse to click by placing the cursor "?" anywhere on the screen to find out what its function is.

### **Options**

This choice modifies some of the parameters of the game concerning the speed of the animation and the range of the 3D view.

**Turbo fog:** remote objects appear in a sort of fog. By increasing or decreasing the turbo fog percentage with the arrows, it is possible to improve speed or sharpness (on the PC only).

**Constant speed:** If the left hand push button is depressed, the game is set to run at a constant speed of 8 frames per second (8 fps). This speed which can be modified with the arrows is not always possible to obtain on some machines but the program attempts to reach that speed sometimes to the detriment to the range of vision which may shorten.

**Constant range:** If the hand push button is depressed, the game is set to display objects at a certain range (modifiable with arrows). If many objects have to be processed, the speed of display can be reduced.

**Screen size:** the size of the 3D window can be reduced to gain in terms of speed or range.

**Default:** puts the options as they were when the game was loaded in.

**Radar:** if the radar push button was depressed, the radar, if there is one (there are no radars set at the beginning of the game) will operate constantly. Otherwise, it will only operate when the formec is at a stop.

**View:** gives a permanent display at the bottom of the screen of the range and current speed of the game.

**Half:** makes all the objects blur during rotations and makes for far more speed.

**OK:** return to the game while maintaining the modifications made.

## **MANAGEMENT OF THE PERSONS LIFE**

### **Energy counter (13)**

This counter represents the persons energy. It drops and turns green when the person moves or uses objects; it indicates tiredness. It drops a lot when the person is hit by a weapon because the persons life is effected. If it is on zero, the person dies and the game is over.

If the person remains inactive, the counter turns red again and rises.

### Rest (14)

When this icon is clicked on, the person goes to sleep and recovers his lost energy faster. But beware, life continues during his sleep and he may be attacked.

### Heat counter (12)

If the temperature in the formec is too high (or too low) the person loses his energy faster. It is essential to use a conditioned air module.

### Oxygen counter (17)

If the person has no more oxygen he quickly loses his energy and dies. It is essential to activate an oxygen sphere before this fatal issue.

## DIALOGUE

By clicking on another formec than icon 15, the person dialogues with each chosen go-between. Access to another screen is then gained. The person represented by the player is on the left and his text appears at the top.

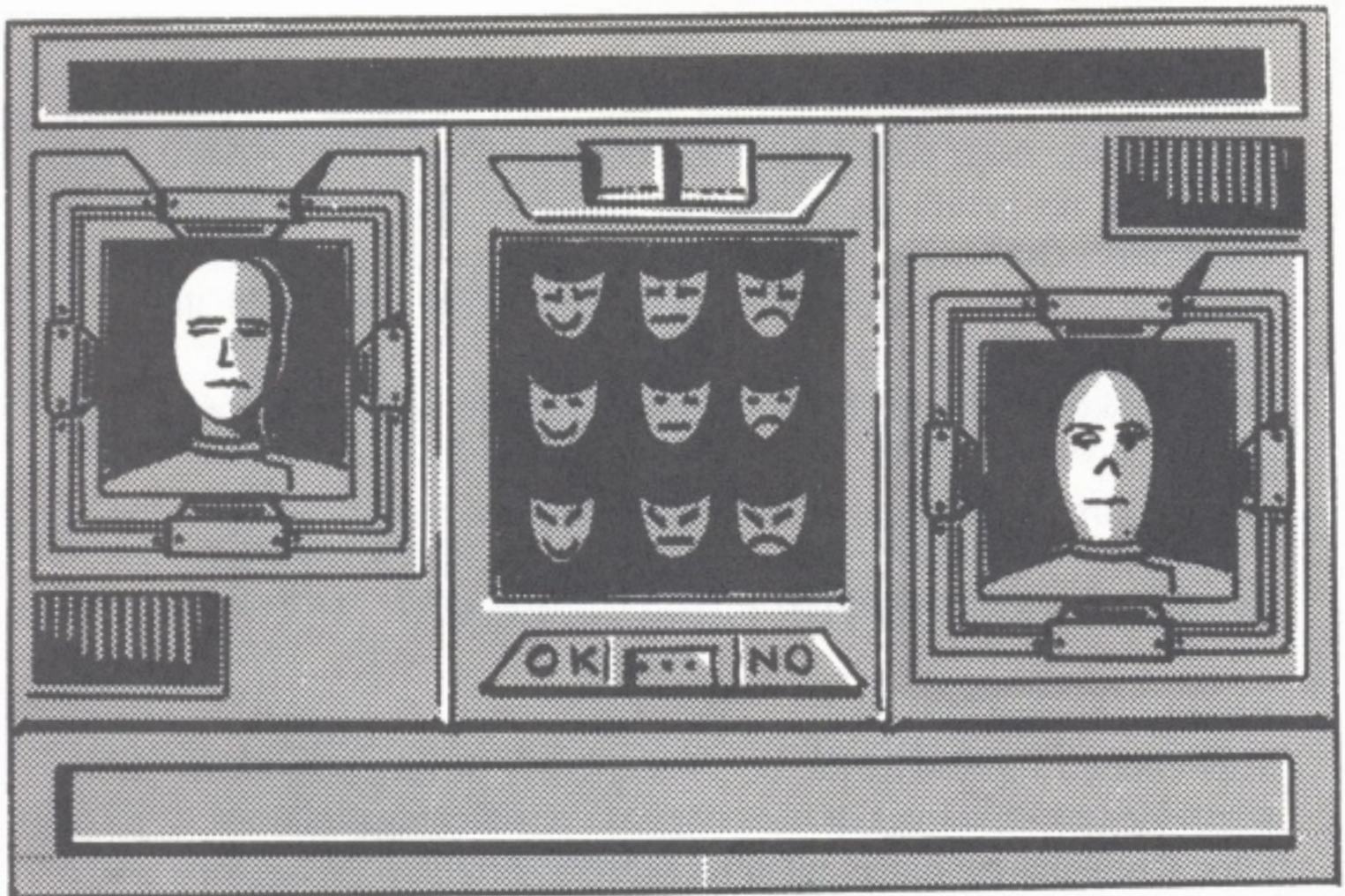

The go-between is on the right and his text appears at the bottom. The player can choose between several phrases to dialogue. By moving

his cursor over the masts at the center of the screen, several propositions are made and the expression of the heros face can be modified. The phrases sometimes differ in terms of meaning. Sometimes the same phrase is said with different intonations or expressions of the face and feelings. These nuances are very important and govern the reaction of your go-between. In some cases it is necessary to be extremely friendly, while other times a frankly disagreeable comportment is necessary to obtain what you want.

To validate the choice of expressions and the desired phrase, click on the mouse left button. Beware! Clicking on the right button will cause the dialogue to break off and bring you back to the normal game mode! If your go-between asks you for an answer which is yes or no during a conversation, you can click on the OK or No icons with the left button. The conversation can be short or longer depending on your mood and that of your go-between. When the later so desires he can end the dialogue. In that case you must click on the mouse to return to the normal mode. Dialogue will enable you to exchange objects or information. It will also modify the feelings of your go-between concerning you. It is essential to control the dialogue to succeed in the game and to resolve the final enigma.

## **DETAILED START UP PROCEDURE**

### **1 - Start up**

#### **• IBM PC and COMPATIBLES**

With your computer booted, insert the game diskette in drive A. If the program consists of several dis-kettes, insert diskette 1, type GO, then press the Return or Enter key. A screen will appear the best graphics card to use and the type of mouse you have. If you agree with the choice, type Y (yes), if you wish to modify the choice, type N (no).

If you type N, two further menus are proposed :

- one offers an alternative list of graphics cards : make your choice according to the card installed in your computer (Hercules, CGA, EGA,

VGA...) by typing the letter corresponding to the card indicated on the screen.

- the other concerns the type of mouse (Microsoft or other). Reply by typing the corresponding letter. Attention : this software does not take into account any joysticks installed on the PC, use the keyboard only for input.

A third choice is offered (the first if you replied Y); it concerns the sound. Attention : the choice "sound with MDO Intersound" should only be made if you possess this interface (see the MDO Intersound description on the last page of this manual).

**NOTE :** if you have a version of MS-DOS 4.0 or higher, you should boot your computer with a system diskette that you have made. This procedure is described in paragraph 3 hereafter.

#### • **ATARI ST and AMIGA**

Insert the diskette in the drive. If the software consists of several diskettes, insert diskette number 1. Switch on your computer, the software loads automatically.

## **2 - The copy protection test**

The test takes place on a screen showing a jackpot machine alongside a keyboard having colored and numbered keys. To start the jackpot spinning, press any key. A code composed of a letter and a three figure number will be displayed. For example C 127.

Using your color card note the color of the square indicated by the code number. For example, green.

On the numeric keypad of your computer, press the key having the number corresponding to this color, then press the Enter or Return key to confirm your choice.

The "S.O.S." key, resumes these instructions in French, English, German, Spanish and Italian. To read them simply press the spacebar.

### **3 - If you possess DOS 4.0 or higher (PC and compatibles only).**

You need to make a system diskette :

#### **1st method :**

1 - Before using the program, insert diskette 1 in drive A (or B) after having started up the computer. At the DOS prompt A:\> (or B:\>) type `INSTALL A:` (or `INSTALL B:`). Confirm it by pressing the Enter or Return key. Then follow the instructions on the screen.

2 - When the operation is completed, re-boot your PC with the system diskette you have just made. Leave it in the drive and re-boot by simultaneously pressing Ctrl - Alt - Del, or by momentarily switching off and then on the computer.

3 - Remove the system diskette from the drive. The game is now ready to be used according to the start up procedure already described.

#### **2nd method :**

1 - Before using the program, insert a blank diskette in drive A (or B) after having started up the computer. Format the diskette, either from your hard disk (C:\>) or from your A or B drive, by typing `FORMAT A: /S` (or `FORMAT B:/S`). Confirm it by pressing the Return or Enter key, then follow the instructions on the screen.

2 - When the operation is completed, re-boot your PC

**For all further use, on diskette or hard disk, first boot your PC using the new system diskette you have made.**

**NOTE :** if after having booted your PC with new system diskette the keyboard is improperly configured, consult the manual accompanying your computer.

### **4 - Installation on IBM-PC and compatibles hard disks**

Create a specific directory (for exemple, GAME) so that you can copy all the files on your diskettes into it.

1 - At the DOS prompt C:\> type `MD GAME` and press Enter or Return.

2 - Type `CD GAME` and Enter or Return. You are now in the directory called GAME, i.e., C:\GAME>.

- 3 - Copy the contents of the diskette into the directory by placing the first diskette into drive A (or B) and by typing COPY A:\*. \* (or B:\*. \*) and pressing the Return or Enter key.
- 4 - Repeat the operation if the program consists of several diskettes until all files have been copied into the directory.
- 5 - Start the game by typing GO.

From now on the game can be started by repeating steps 2 and 5.

## THE MDO INTERSOUND INTERFACE

With MDO INTERSOUND, the sound interface for non portable PC compatibles, the quality of sound obtained is comparable with the best computers.

This interface can be found at your computer dealer or simply by asking COKTEL VISION.

Should any problems be encountered please contact our after-sales service.