

EmuMovies

Nintendo

Nintendo of America Inc.
P.O. Box 957, Redmond, WA 98052 U.S.A.

PRINTED IN JAPAN

CLU CLU LAND™

INSTRUCTION BOOKLET



Look for this seal on all software and accessories for your Nintendo Entertainment System. It represents Nintendo's commitment to bringing you only the highest quality products. Items not carrying this seal have not been approved by Nintendo, and are not guaranteed to meet our standards of excellence in workmanship, reliability and most of all, entertainment value.



Thank you for selecting the Nintendo® Entertainment System Clu Clu Land™ Pak.

OBJECT OF THE GAME/GAME DESCRIPTION

The evil Sea Urchin has hidden a pattern of gold bars on Clu Clu Land in an underground mystery maze. It's up to you to find the gold before time runs out. But beware — the Sea Urchin will do everything in his power to stop you. Because of some strange power that works in Clu Clu Land, you'll find it hard to turn around freely. The only way you can turn is by hooking a hand around a turn post or bouncing off a wall. Face the Sea Urchin alone, or with a friend and try to uncover the mystery pattern.

Please read this instruction booklet to ensure proper handling of your new game, and then save the booklet for future reference.

1. PRECAUTIONS

- 1) This is a high precision game. It should not be stored in places that are very hot or cold. Never hit it or drop it. Do not take it apart.
- 2) Avoid touching the connectors, do not get them wet or dirty. Doing so may damage the game.
- 3) Do not clean with benzene, paint thinner, alcohol or other such solvents.

Note: In the interest of product improvement, Nintendo Entertainment System specifications and design are subject to change without prior notice.

2. NAMES OF CONTROLLER PARTS AND OPERATING INSTRUCTIONS

Controller 1 – for 1 player game.

Controller 2 – for second player in 2 player game.

Controller 1/Controller 2

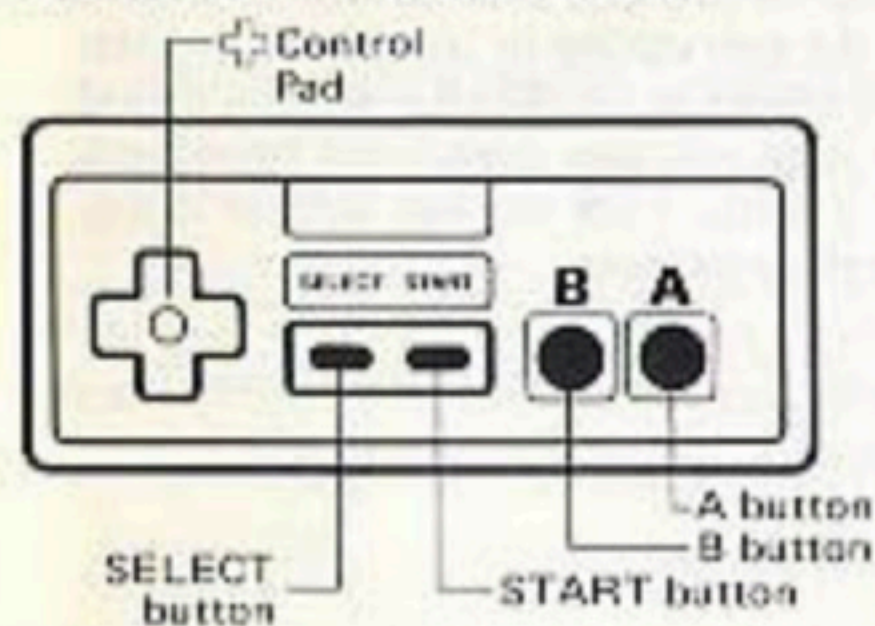

[A and B buttons]



Sends out electric shock waves.
Can send out 2 at one time.

 Control pad Moves "Bubbles"

At start-up Decide which direction to start off in.

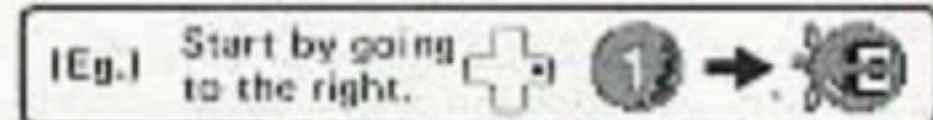

During play The hand comes out in the direction in which you press the button.

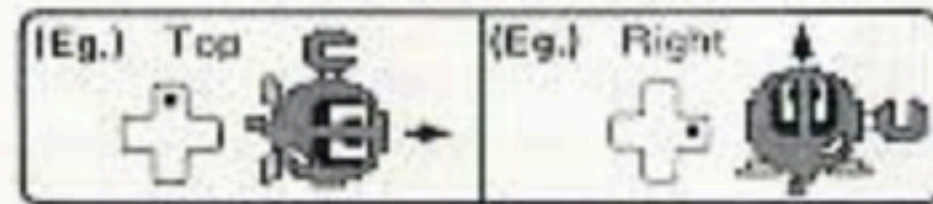
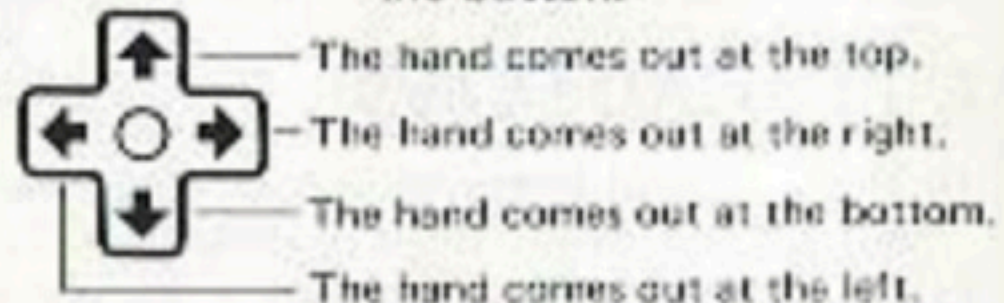

SELECT button

Use this button to move the arrowhead (▷) to the game you wish to play.

START button

Press this button to begin.

Pause:

If you wish to interrupt play in the middle of a game, press the START button. The pause tone will sound, and the game will stop. Press the START button again when you wish to continue playing. The game will continue from where you left off.

* If you press the START or SELECT button during the demonstration sequence, the game menu will appear.

* The top score disappears once the power switch is turned off.

[Characters]

Bubbles

- A hand comes out from her body.
- She bounces off walls like a ball, but if she's hit by one of Sea Urchin's needles, she bursts.
- She attacks Sea Urchin by giving out electric shocks.



Red (Controller 1) Green (Controller 2)

Sea Urchin

- If it finds Bubbles it tries to bump up against her.
- If it is zapped by electric shock waves, its power weakens and it shrivels up.



Gold Bar

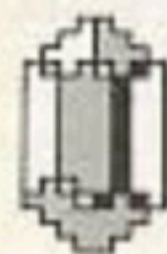

- The treasure that Bubbles is searching for.

Black Hole



- The Sea Urchin lives here. If Bubbles falls inside, she will be swallowed up.

Rubber Trap



- The Sea Urchin sets it up as a trap. Hit against it and you will get thrown back.

Turnpost



- Bubbles hooks her hand around this to turn.

Bonus Fruit

(800 points)

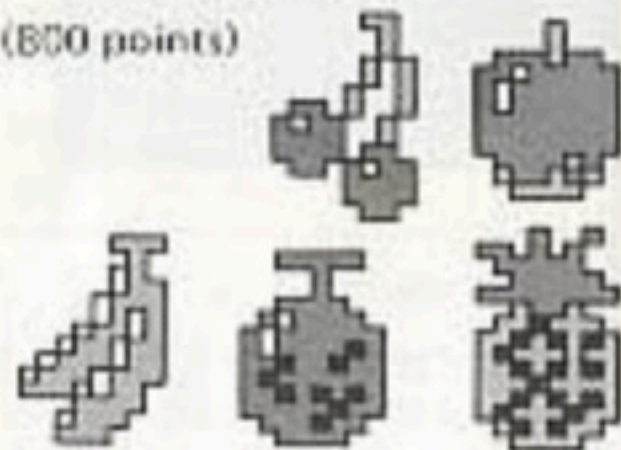

Bonus Sack



11,500 points!

Bonus Flag

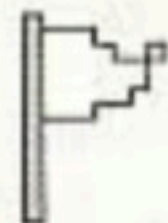

- You get an extra Bubbles.

Bonus Timer









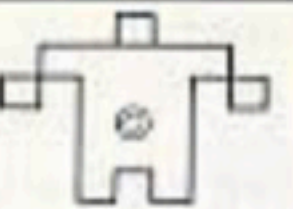
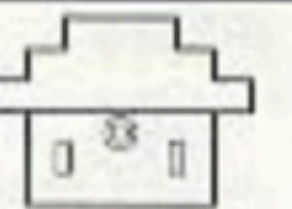
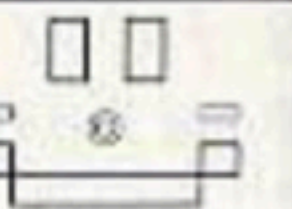

- The screen suddenly brightens and the Sea Urchin, the time counter, and the opposing player (in a 2 player game) freeze for as long as the bonus time lasts.

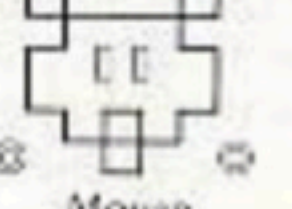
3. HOW TO PLAY

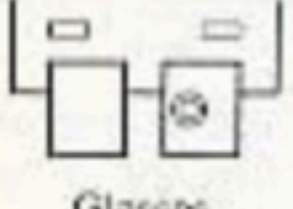
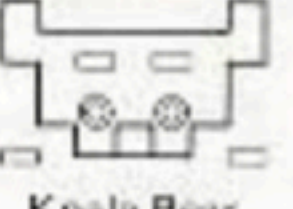
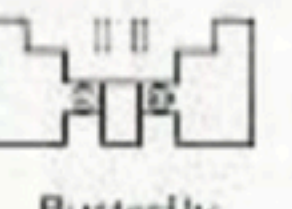
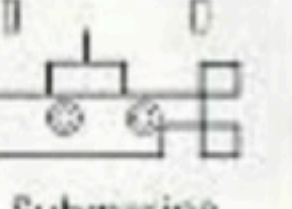
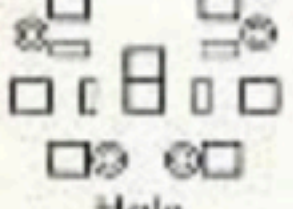
Rules and tips

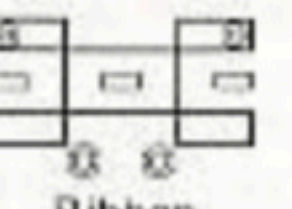
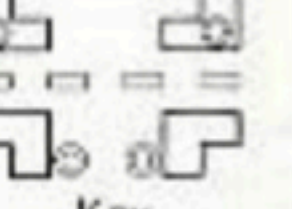
- If Bubbles passes above a gold bar that the Sea Urchin has hidden, it appears on the screen.
- Try to find all of the gold bars in the time given. The remaining time and the remaining number of gold bars are displayed at the top of the screen. If you find all of the gold bars, the screen is cleared.
- Bubbles will stick out a hand in the direction pressed on the  control pad. If you hold the control pad down, Bubbles will go around and around the turnpost. The direction she flies off in depends on your timing in releasing the control pad.
- Try to control the horrible Sea Urchin with electric shock waves (buttons A and B). However, the Sea Urchin will only be stunned by the shocks for a moment, and after awhile will recover. To get rid of the Sea Urchin for good, you must try to crush it against the outside wall of Clu Clu Land while it is stunned and its color is yellow.
- Sea Urchin hides the gold bars in a pattern forming a certain shape so it won't forget where the bars are hidden. You don't know what the shape will be, but you can get a hint from the color of the outside wall of Clu Clu Land.
- Clu Clu Land comes in 5 different colors and each color has 4 different pattern forms, for a total of 20.

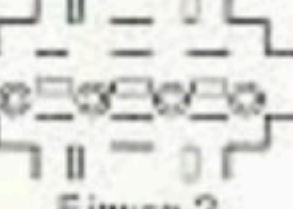
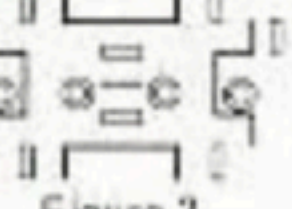
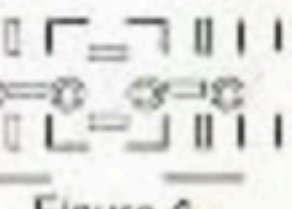
Pink	 Heart	 Person	 House	 Face
Green	 Clown	 Eagle	 Mouse	 Spade
Blue	 Glasses	 Koala Bear	 Butterfly	 Submarine
Purple	 Hole	 The letter H	 Ribbon	 Key
Yellow	 Figure 1	 Figure 2	 Figure 3	 Figure 4

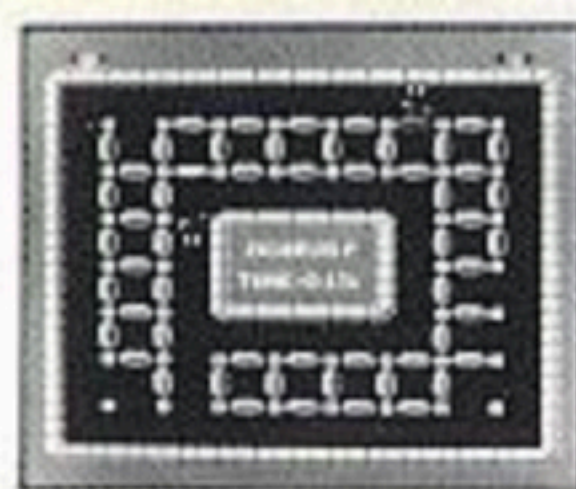

- After the last yellow scene you get a bonus round. In the bonus round, you just have to find and grab as many gold bars as you can.
- After you have gone through 21 scenes (including the bonus round), you have been all the way through Clu Clu Land. You start over again from the 22nd scene.
- From the 22nd scene on, passing over a gold bar twice covers it again. No points are awarded for this. To complete the pattern form and move onto the next, all gold bars must be uncovered.

You lose a Bubbles when:

- A player bumps up against the Sea Urchin.
- A player falls into a black hole. (Unless A player is hooked around a turnpost to turn at the time).
- The timer runs out (TIME 000).

Tips/Hints

- In the 2-player game, if both Bubbles get stuck together, stick out a hand and grab a turnpost. That should separate them.
- If you get caught in a double trap on the mouse or butterfly scene, have the other Bubbles (the other player) bump into you to help you out.

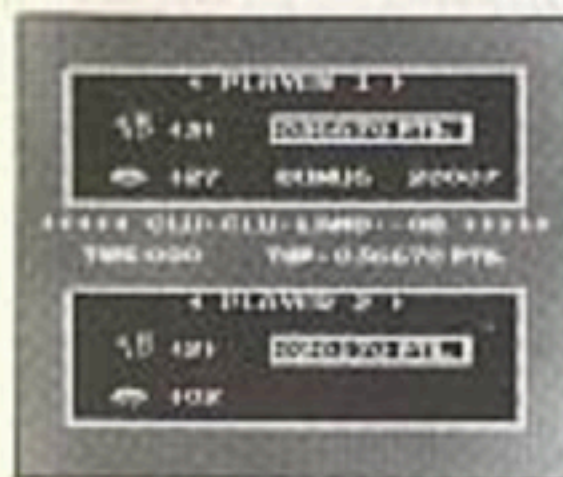

Scoring

- Points are totaled and displayed on the score display screen. (Fruit, sacks and other bonus points are added up during play.)
 - * Gold Bar 100 points
 - * Sea Urchin 500 points
 - * TIME X X X time left over counts as extra points
- In the 1 player game, if you finish a round within 300 on the timer 2,000 points
- In the 2 player game, the one who gets the most gold bars 2,000 points
- If you get all the gold bars on the bonus round 30 points

NOTE: If, while playing in the bonus mode, the player wins all the gold nuggets (perfect), 30 points are added to the score although the instructions on the screen say that for a perfect score 3,000 points are added.

COMPLIANCE WITH FCC REGULATIONS

This equipment generates and uses radio frequency energy and if not installed and used properly, that is, in strict accordance with the manufacturer's instructions, may cause interference to radio and television reception. It has been type tested and found to comply with the limits for a Class B computing device in accordance with the specifications in Subpart J of Part 15 of FCC Rules, which are designed to provide reasonable protection against such interference in a residential installation. However, there is no guarantee that interference will not occur in a particular installation. If this equipment does cause interference to radio or television reception, which can be determined by turning the equipment off and on, the user is encouraged to try to correct the interference by one or more of the following measures:

- Reorient the receiving antenna
- Relocate the NES with respect to the receiver
- Move the NES away from the receiver
- Plug the NES into a different outlet so that computer and receiver are on different circuits.

If necessary, the user should consult the dealer or an experienced radio/television technician for additional suggestions. The user may find the following booklet prepared by the Federal Communications Commission helpful:

How to Identify and Resolve Radio-TV Interference Problems.

This booklet is available from the U.S. Government Printing Office, Washington, D.C. 20402, Stock No. 004-000-00345-4.

[Faint, illegible text on the left page, possibly bleed-through from the reverse side.]

[Faint, illegible text on the right page, possibly bleed-through from the reverse side.]

90-DAY LIMITED WARRANTY NINTENDO GAME PAKS

90-DAY LIMITED WARRANTY:

Nintendo of America, Inc. ("Nintendo") warrants to the original consumer purchaser that this Nintendo Game Pak ("PAK") (not including Game Pak Accessories or Robot Accessories) shall be free from defects in material and workmanship for a period of 90 days from date of purchase. If a defect covered by this warranty occurs during this 90-day warranty period, Nintendo will repair or replace the PAK, at its option, free of charge.

To receive this warranty service:

1. DO NOT return your defective Game Pak to the retailer.
2. Notify the Nintendo Consumer Service Department of the problem requiring warranty service by calling: Outside Washington State (800) 422-2802, or Inside Washington State (206) 882-2040. Our Consumer Service Department is in operation from 8:00 A.M. to 5:00 P.M. Pacific Time, Monday through Friday.
3. If the Nintendo service technician is unable to solve the problem by phone, he will provide you with a Return Authorization number. Simply record this number on the outside packaging of your defective PAK, and return your PAK freight prepaid, at your risk of damage, together with your sales slip or similar proof-of-purchase within the 90-day warranty period to:

Nintendo of America, Inc.
NES Consumer Service Department
4020 - 150th Avenue N.E.
Redmond, WA 98052

This warranty shall not apply if the PAK has been damaged by negligence, accident, unreasonable use, modification, tampering, or by other causes unrelated to defective materials or workmanship.

REPAIRS AFTER EXPIRATION OF WARRANTY:

If the PAK develops a problem after the 90-day warranty period, you may contact the Nintendo Consumer Service Department at the phone number noted above. If the Nintendo service technician is unable to solve the problem by phone, he may provide you with a Return Authorization number. You may then record this number on the outside packaging of the defective PAK and return the defective PAK freight prepaid to Nintendo, enclosing a check or money order for \$10.00 payable to Nintendo of America, Inc. Nintendo will, at its option, subject to the conditions above, repair the PAK or replace it with a new or repaired PAK. If replacement PAKS are not available, the defective PAK will be returned and the \$10.00 payment refunded.

WARRANTY LIMITATIONS:

ANY APPLICABLE IMPLIED WARRANTIES, INCLUDING WARRANTIES OF MERCHANTABILITY AND FITNESS FOR A PARTICULAR PURPOSE, ARE HEREBY LIMITED TO NINETY DAYS FROM THE DATE OF PURCHASE AND ARE SUBJECT TO THE CONDITIONS SET FORTH HEREIN. IN NO EVENT SHALL NINTENDO BE LIABLE FOR CONSEQUENTIAL OR INCIDENTAL DAMAGES RESULTING FROM THE BREACH OF ANY EXPRESS OR IMPLIED WARRANTIES.

The provisions of this warranty are valid in the United States only. Some states do not allow limitations on how long an implied warranty lasts or exclusion of consequential or incidental damages, so the above limitations and exclusion may not apply to you. This warranty gives you specific legal rights, and you may also have other rights which vary from state to state.